

REVISION			
REV.	DESCRIPTION	DATE	APPROVED

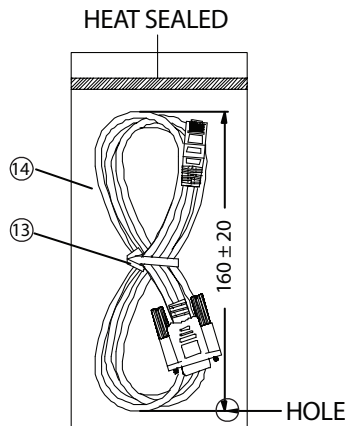
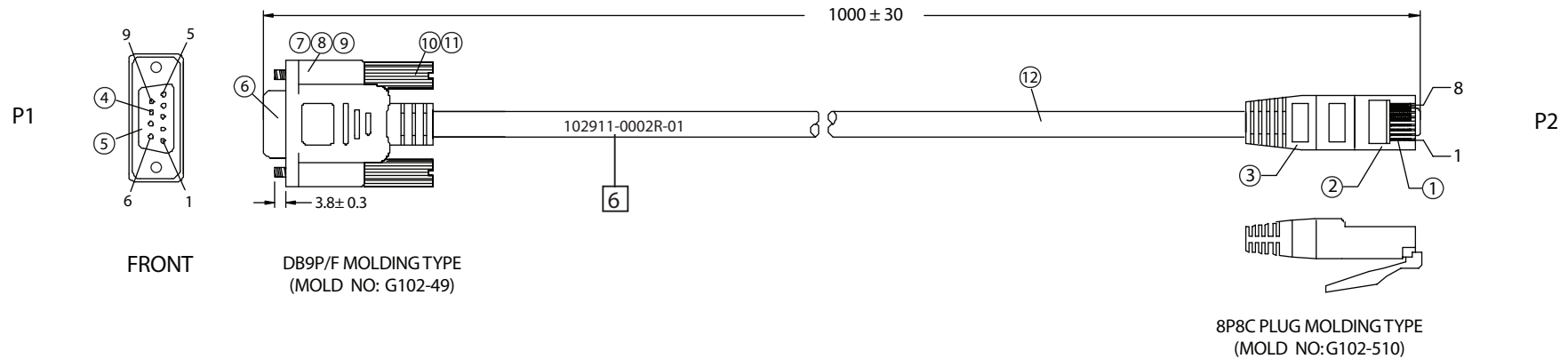

### PIN OUT

P1		P2
2	RED	3
3	GREEN	4
4	BLACK	2
5	YELLOW	5

### NOTES:

- CABLE:  
(28AWGx4c+FOIL)x1  
OUTER JACKET: BLACK, OD: 4.0 ± 0.2  
PRINTING: E166307 AWM 2464 28AWG 80°C 300V VW-1
- CONNECTORS: 8P8C PLUG TO DB9P FEMALE
- HOOD: DB9P/F MOLDING TYPE, 8P8C PLUG CRIMPING TYPE, COLOR: BLACK
- ELECTRICAL TEST:  
<1>.100% OPEN SHORT & MISS WIRE TEST  
<2>.INSULATION RESISTANCE: DC400V 10M ohm MIN.  
<3>.CONDUCTOR RESISTANCE: 3 ohm MAX.
- PACKING: 1PC/POLYBAG
- CUSTOMER PART NUMBER PRINTED ON THE CABLE

No.	PARTS NAME	SPECIFICATION STANDARD	QTY	REMARKS
①	8P8C / M - CONTACT	PHOSPHOR BRONZE / GOLD PLATED 3u"	8	
②	8P8C / M - HOOD	PC TRANSPARENT CRIMP TYPE	1	
③	8P8C / M - OUTER MOLD	45P PVC / COLOR: BLACK	1	
④	DB9P / F - CONTACT	BRASS / GOLD FLASH	9	
⑤	DB9P / F - INSULATOR	PBT / BLACK	1	
⑥	DB9P / F - SHELL	STEEL / NICKEL PLATED	1	
⑦	DB9P / INNER MOLD	PE NATURAL	1	
⑧	DB9P / F - AL / FOIL	WIDTH 25mm x LENGTH 50mm	1	
⑨	DB9P / F - OUTER MOLD	45P PVC / COLOR: BLACK	1	
⑩	THUMB SCREW	UNC #4-40 Ø 4xL40 NICKEL PLATED	2	
⑪	SCREW-MOLD	35P PVC / COLOR: BLACK	2	
⑫	CABLE	KL05083ABK01A	1	
⑬	MINI TIE	PE / BLACK	1	
⑭	POLYBAG	PE 0.08 x 80 x 220mm	1	

Dim range (mm)	Tolerance +/- (mm)	Qualtek Electronics Corp. WCT DIVISION		
		Part Number: 0061QU-02		RoHS Compliant
0-1	0.15	Description: 8P8C PLUG - DB9P / F		
1-6	0.20	RFQ 6831	UNIT: mm	Approved / Date
6-18	0.30			
18-50	0.50	Drawn / Date	Checked / Date	Approved / Date
50-120	0.70	B.Grubb 04-04-07	04-04-07	JJH / 04-04-07
120-250	0.90			
250-500	1.20			