

CLASSIFICATION	PRODUCT SPECIFICATION	No. DS-1026-2400-102	REV. 1.9
SUBJECT	CLASS 2 BLUETOOTH LOW ENERGY SPP MODULE	PAGE	1 of 35
CUSTOMER'S CODE PAN1026	PANASONIC'S CODE ENW89837AxKF	DATE	16.06.2017

# Product Specification

Applicant/Manufacturer  
Hardware

Panasonic Industrial Devices Europe GmbH  
Zeppelinstrasse 19  
21337 Lüneburg  
Germany

Applicant/Manufacturer  
Software

TOSHIBA Electronics Europe GmbH  
Hansaallee 181  
40549 Düsseldorf  
Germany

Software Version

Please refer to chapter 20/22

By purchase of any of the products described in this document the customer accepts the document's validity and declares their agreement and understanding of its contents and recommendations. Panasonic reserves the right to make changes as required at any time without notification. Please consult the most recently issued Product Specification before initiating or completing a design.

© Panasonic Industrial Devices Europe GmbH 2017.

All rights reserved.

This Product Specification does not lodge the claim to be complete and free of mistakes.

Power Electronics R&D Center Wireless Connectivity Panasonic Industrial Devices Europe GmbH	APPROVED genehmigt	CHECKED geprüft	DESIGNED erstellt
---	-----------------------	--------------------	----------------------

CLASSIFICATION	PRODUCT SPECIFICATION	No. DS-1026-2400-102	REV. 1.9
SUBJECT	CLASS 2 BLUETOOTH LOW ENERGY SPP MODULE	PAGE	2 of 35
CUSTOMER'S CODE PAN1026	PANASONIC'S CODE ENW89837AxKF	DATE	16.06.2017

## TABLE OF CONTENTS

1	About this document.....	4
1.1	Purpose.....	4
1.2	Revision History .....	4
1.3	Related Documents .....	4
1.4	General Information .....	5
1.5	Contact Us .....	6
2	Key Features .....	7
3	Applications for the Module.....	7
4	Bluetooth Low Energy .....	7
5	Description for the Module .....	8
6	Detailed Description .....	8
6.1	PAN1026 Terminal Layout.....	8
6.2	PAN1026 Terminal Description.....	9
6.3	UART Interface .....	11
7	Bluetooth Features.....	14
8	Block Diagram .....	14
9	Test Conditions .....	15
10	General Device Requirements and Operation .....	15
10.1	Absolute Maximum Ratings .....	15
10.2	Recommended Operating Conditions .....	15
10.3	Current Consumption.....	16
11	Bluetooth RF Performance.....	16
11.1	Bluetooth Characteristics .....	16
12	Soldering Temperature-Time Profile (for reflow soldering) .....	17
13	Module Dimension.....	18
14	PAN1026 FootPrint of the Module .....	19
15	Case Marking .....	20
15.1	Example for Marking .....	20
15.2	Marking Definition .....	20
16	Mechanical Requirements.....	20
17	Reliability Tests .....	21
18	Cautions .....	22
18.1	Design Notes .....	22
18.2	Installation Notes .....	22
18.3	Usage Conditions Notes .....	23
18.4	Storage Notes .....	23
18.5	Safety Cautions.....	23
18.6	Other cautions.....	24
18.7	Life Support Policy .....	24
19	Packaging.....	25
19.1	Tape Dimension.....	25
19.2	Packing in Tape .....	25
19.3	Component Direction .....	26
19.4	Reel Dimension.....	26

CLASSIFICATION	PRODUCT SPECIFICATION	No. DS-1026-2400-102	REV. 1.9
SUBJECT	CLASS 2 BLUETOOTH LOW ENERGY SPP MODULE	PAGE	3 of 35
CUSTOMER'S CODE PAN1026	PANASONIC'S CODE ENW89837AxKF	DATE	16.06.2017

19.5	Label for Package .....	27
19.6	Total Package .....	27
20	Ordering Information .....	28
21	RoHS and REACH Declaration .....	28
22	Software .....	29
22.1	Software Description .....	29
22.2	Software Version Information .....	29
22.3	Software block diagram .....	30
23	Regulatory Information .....	31
23.1	FCC for US .....	31
23.2	Industry Canada Certification .....	33
23.3	European Conformity according to RED (2014/53/EU) .....	34
23.4	Japanese Radio Law Compliance: .....	35
24	Bluetooth Qualification .....	35

CLASSIFICATION	PRODUCT SPECIFICATION	No. DS-1026-2400-102	REV. 1.9
SUBJECT	CLASS 2 BLUETOOTH LOW ENERGY SPP MODULE	PAGE	4 of 35
CUSTOMER'S CODE PAN1026	PANASONIC'S CODE ENW89837AxKF	DATE	16.06.2017

## 1 ABOUT THIS DOCUMENT

### 1.1 PURPOSE

This Product Specification applies to Panasonic's Class 2 Bluetooth®<sup>1</sup> classic and low energy dual mode module, series number: PAN1026.

### 1.2 REVISION HISTORY

Revision	Date	Modification / Remarks
0.1	November 2012	1 <sup>st</sup> preliminary version.
0.2	January 2013	Update chapter 21 with the latest declaration. Correct chapter 10.3 with the latest current values measured on the reference design. Made the description for the USB ports in chapter 6.2 more precised.
0.3	October 2013	Editorial changes.
0.4	October 2013	Add IC notice in French.
0.5	December 2013	Added current consumption for BLE and LPM modes.
1.0	February 2014	Updated Bluetooth chapter and changed datasheet status.
1.1	March 2014	Corrected Pin Table with IO support.
1.2	June 2014	Corrected VCC voltage in Pin Table.
1.3	September 25, 2014	Added DoC.
1.4	May 2015	Added missing Bluetooth QDIDs to chapter <b>Fehler! Verweisquelle konnte nicht gefunden werden..</b>
1.5	January 2016	Added information about the C, L, R values below block diagram.
1.6	November 2016	Deleted low power supply voltage.
1.7	November 2016	Added MIC ID.
1.8	June 2017	Changed EU regulatory information for RED.
1.9	June 2017	Editorial changes.

### 1.3 RELATED DOCUMENTS

Please refer to the Panasonic Wireless Connectivity website for further information on our products and related documents:

For complete Panasonic product details in the **EU**, visit  
<http://pideu.panasonic.de/products/wireless-modules.html>

For complete Panasonic product details in **North America**, visit  
<http://www.panasonic.com/rfmodules>

<sup>1</sup> Bluetooth is a registered trademark of the Bluetooth Special Interest Group.

CLASSIFICATION	PRODUCT SPECIFICATION	No. DS-1026-2400-102	REV. 1.9
SUBJECT	CLASS 2 BLUETOOTH LOW ENERGY SPP MODULE	PAGE	5 of 35
CUSTOMER'S CODE PAN1026	PANASONIC'S CODE ENW89837AxKF	DATE	16.06.2017

## 1.4 GENERAL INFORMATION

This document may contain errors. Panasonic reserves the right to make corrections, modifications, enhancements, improvements, and other changes to its literature at any time. Customers should obtain the latest relevant information before placing orders and should verify that such information is current and complete. All products are sold subject to Panasonic's terms and conditions of sale supplied at the time of order acknowledgment.

### Engineering Samples (ES)

If Engineering Samples are delivered to the customer, these samples have the status "Engineering Samples". This means that the design of this product is not yet concluded. Engineering Samples may be partially or fully functional, and they may differ from the published Product Specification.

Engineering Samples are not qualified and they are not to be used for reliability testing or series production.

### Disclaimer

The customer acknowledges that samples may deviate from the Product Specification and may bear defects due to their status of development and the lack of qualification mentioned above.

Panasonic rejects any liability or product warranty for Engineering Samples. In particular, Panasonic disclaims liability for damages caused by:

- The use of the Engineering Sample other than for evaluation purposes, particularly the installation or integration in another product to be sold by the customer,
- Deviation or lapse in function of the Engineering Sample,
- Improper use of the Engineering Sample.

Panasonic Industrial Devices Europe GmbH disclaims any liability for consequential and incidental damages. In case of any queries regarding the Engineering Samples, please contact your local sales partner or the related product manager.

CLASSIFICATION	PRODUCT SPECIFICATION	No. DS-1026-2400-102	REV. 1.9
SUBJECT	CLASS 2 BLUETOOTH LOW ENERGY SPP MODULE	PAGE	6 of 35
CUSTOMER'S CODE PAN1026	PANASONIC'S CODE ENW89837AxKF	DATE	16.06.2017

## 1.5 CONTACT US

Please contact your local Panasonic Sales office for details on additional product options and services:

For Panasonic Sales assistance in the **EU**, visit

<https://eu.industrial.panasonic.com/about-us/contact-us>

Email: [wireless@eu.panasonic.com](mailto:wireless@eu.panasonic.com)

For Panasonic Sales assistance in **North America**, visit the Panasonic Sales & Support Tool to find assistance near you at

<https://na.industrial.panasonic.com/distributors>

Please visit the **Panasonic Wireless Technical Forum** to submit a question at

<https://forum.na.industrial.panasonic.com>

Please refer to the Panasonic Wireless Connectivity website for further information on our products and related documents:

For complete Panasonic product details in the **EU**, visit

<http://pideu.panasonic.de/products/wireless-modules.html>

For complete Panasonic product details in **North America**, visit

<http://www.panasonic.com/rfmodules>

CLASSIFICATION	PRODUCT SPECIFICATION	No. DS-1026-2400-102	REV. 1.9
SUBJECT	CLASS 2 BLUETOOTH LOW ENERGY SPP MODULE	PAGE	7 of 35
CUSTOMER'S CODE PAN1026	PANASONIC'S CODE ENW89837AxKF	DATE	16.06.2017

## 2 KEY FEATURES

- Bluetooth Classic and BLE (Dual Mode) support
- Bluetooth Classic 2.1 embedded SPP profile with high level API commands
- Bluetooth 4.0 (LE) embedded GATT profile with high level API commands, compatible to Toshiba reference BLE profiles
- Operational Temperature Range -40 / 85 degree C
- Dimension 15.6mm x 8.7m x 1.9mm
- Internal crystal oscillator (26MHz)
- Integrated shielding to resist EMI
- No external components needed
- High sensitivity (-88 dBm typ.)
- Tx power control up to a maximum of 4.0 dBm (typical)

## 3 APPLICATIONS FOR THE MODULE

All Embedded Wireless Applications

- Access Points
- Industrial Control
- Medical
- Scanners
- Wireless Sensors
- Low Power
- Proximity
- Smart Phone
- Access Points
- Temperature
- Wellness
- Sports

## 4 BLUETOOTH LOW ENERGY

Bluetooth Low Energy (BLE) is a part of Bluetooth Ver. 4.0, BT 4.0 covers both BLE as well as BT classic 2.1 and 3.0. If both are implemented in one device it is called dual mode. Dual mode chips implement the low energy specification, providing connectivity to coin cell battery applications. Dual mode combines low energy with the power of classic Bluetooth and are likely to become a de facto feature in almost all new Bluetooth enabled cellular phones, computers or portable communication nodes.

Bluetooth Low Energy (BLE) is not backwards compatible with previous Bluetooth classic standards (2.1+EDR or 3.0). Dual mode Bluetooth 4.0 is backwards compatible but is not practical for low power devices but targeted to gateway products



CLASSIFICATION	PRODUCT SPECIFICATION	No. DS-1026-2400-102	REV. 1.9
SUBJECT	CLASS 2 BLUETOOTH LOW ENERGY SPP MODULE	PAGE	8 of 35
CUSTOMER'S CODE PAN1026	PANASONIC'S CODE ENW89837AxKF	DATE	16.06.2017

## 5 DESCRIPTION OF THE MODULE

The PAN1026 is a short-range Class 2 BLE dual mode module for implementing Bluetooth functionality into various electronic devices. A block diagram can be found in chapter 8.

## 6 DETAILED DESCRIPTION

### 6.1 PAN1026 TERMINAL LAYOUT

Top view, Application PCB

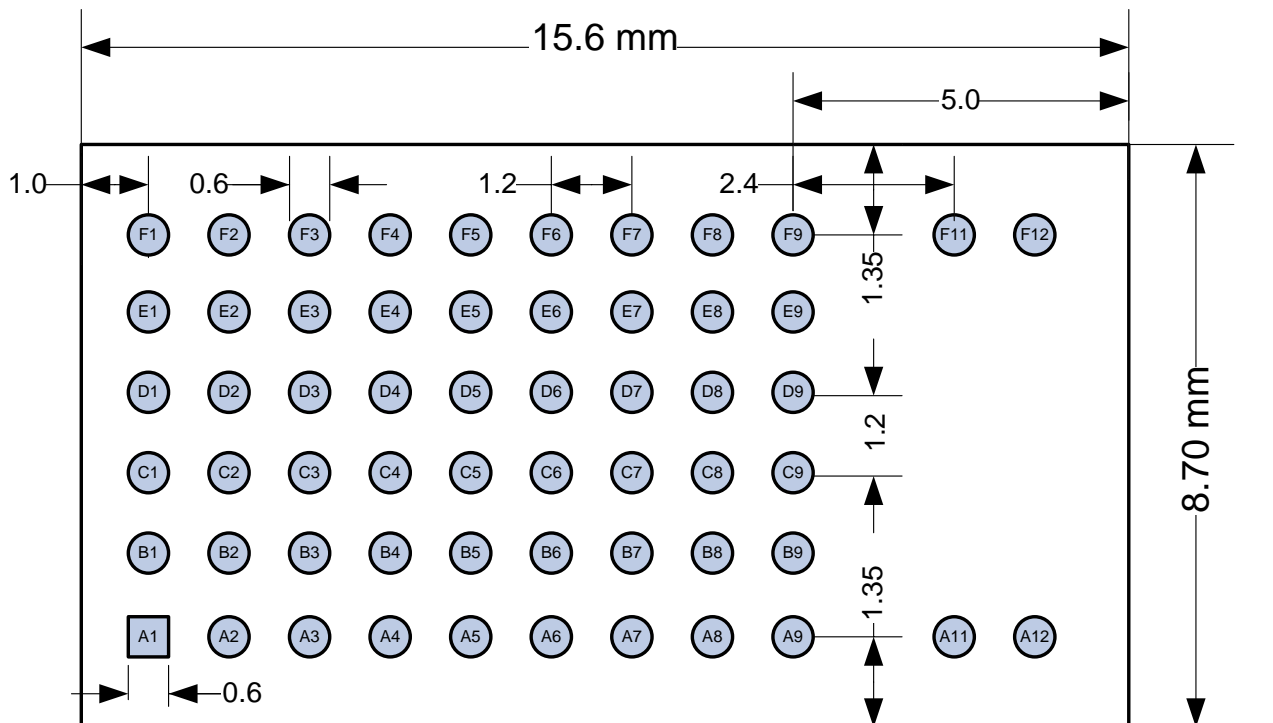



CLASSIFICATION	PRODUCT SPECIFICATION	No. DS-1026-2400-102	REV. 1.9
SUBJECT	CLASS 2 BLUETOOTH LOW ENERGY SPP MODULE	PAGE	9 of 35
CUSTOMER'S CODE PAN1026	PANASONIC'S CODE ENW89837AxKF	DATE	16.06.2017

## 6.2 PAN1026 TERMINAL DESCRIPTION

No	Pin Name	GPIO Number	Pin Type	Description
A1	GND		Ground Pin	Connect to Ground
A2	NC		NC	Not connected, leave open
A3	Reset		Digital Input	Reset, active-low
A4	VCC		Power	analog/digital power supply connection
A5	VCC		Power	analog/digital power supply connection
A6	VCC		Power	analog/digital power supply connection
A7	GND		Ground Pin	Connect to Ground
A8	NC		NC	Not Connected
A9	GND		Ground Pin	Connect to Ground
A11	GND		Ground Pin	Connect to Ground
A12	GND		Ground Pin	Connect to Ground
B1	NC		NC	Not connected, leave open
B2	BTS	GPIO 11		
B3	BTA	GPIO 10		
B4	NC		NC	Not connected, leave open
B5	NC		NC	Not connected, leave open
B6	NC		NC	Not connected, leave open
B7	NC		NC	Not connected, leave open
B8	NC		NC	Not connected, leave open
B9	NC		NC	Not connected, leave open
C1	CS0X	GPIO 17		
C2	BTI	GPIO 13		
C3	WIA	GPIO 12		
C4	NC		NC	Not connected, leave open
C5	NC		NC	Not connected, leave open
C6	PCMCLK	GPIO 04	Digital I/O	PCM Clock
C7	FSYNC	GPIO 05	Digital I/O	PCM Synchronisation
C8	GND		Ground Pin	Connect to Ground
C9	GND		Ground Pin	Connect to Ground
D1	CS1X	GPIO 18		
D2	DIN	GPIO 16		
D3	GPIO1	GPIO 01	Digital I/O	
D4	USB*/GPIO0		Digital I/O	USB direct is not currently supported by the IC and therefore you may use this pin as normal GPIO0. When USB is supported the, pin will be → Select USB (Connect to PIN E4)
D5	NC		NC	Not connected, leave open
D6	PCMIN	GPIO 03	Digital Input	PCM In Not supported
D7	GND		Ground Pin	Connect to Ground
D8	GND		Ground Pin	Connect to Ground
D9	ANT		RF - Signal	Antenna Pin (Not connected for standard version)

CLASSIFICATION	PRODUCT SPECIFICATION	No. DS-1026-2400-102	REV. 1.9
SUBJECT	CLASS 2 BLUETOOTH LOW ENERGY SPP MODULE	PAGE	10 of 35
CUSTOMER'S CODE PAN1026	PANASONIC'S CODE ENW89837AxKF	DATE	16.06.2017

No	Pin Name	GPIO Number	Pin Type	Description
E1	SDA	GPIO 15	Digital I/O	I2C Interface (Only Internal) Connect to Testpin
E2	SCL	GPIO 14	Digital I/O	I2C Interface (Only Internal) Connect to Testpin
E3	VDD_USB		Power	USB direct is not currently supported by the IC therefore put this pin to to GND. If USB will be supported in the next revision, connect to VCC.
E4	USB*			USB direct is not currently supported by the IC Leave this pin open.. Whjen USB is supported the pin would be → Select USB (Connect to PIN D4).
E5	CLKREQ		Digital Output	Active High once crystal frequency is stable
E6	UART RXD		Digital Input	UART RXD
E7	PCMOUT	GPIO 02	Digital Output	PCM Output Not supported
E8	GND		Ground Pin	Connect to Ground
E9	GND		Ground Pin	Connect to Ground
F1	GND		Ground Pin	Connect to Ground
F2	EEPROM_WP		Digital Input	Internal EEPROM Write Protect (Active High)
F3	USB_P		Digital I/O	USB direct is not currently supported by the IC therefore put this pin to GND. Whjen USB is supported the pin would be → USB Data In/Out
F4	USB_M		Digital I/O	USB direct is not currently supported by the IC therefore put this pin to GND. Whjen USB is supported the pin would be → USB Data In/Out
F5	UART CTS		Digital Input	UART CTS
F6	SLEEPCLK		Digital Input	Input Clock for 32.768KHz
F7	UARTTXD		Digital Output	UART TX
F8	UARTRTS		Digital Output	UART RTS
F9	GND		Ground Pin	Connect to Ground
F11	GND		Ground Pin	Connect to Ground
F12	GND		Ground Pin	Connect to Ground

CLASSIFICATION	PRODUCT SPECIFICATION	No. DS-1026-2400-102	REV. 1.9
SUBJECT	CLASS 2 BLUETOOTH LOW ENERGY SPP MODULE	PAGE	11 of 35
CUSTOMER'S CODE PAN1026	PANASONIC'S CODE ENW89837AxKF	DATE	16.06.2017

### 6.3 UART INTERFACE

#### 6.3.1 Features

- Full-duplex 4-wire data transfer: RX, TX, RTS, CTS
- Programmable baud rate: 2400bps to 4.33 Mbps
- Data format (No parity bit): LSB first
- Start bit (1-bit)
- Data bit (8-bit):
- Stop bit (1-bit)
- Error detection: Character timeout, Overrun error, Framing error

TC35661 UART interface is used to transfer control command and data and is multiplexed with GPIO pin. After the release reset state, TC35661 firmware sets UART interface mode to the related GPIO pins. The default bit rate depends on the selection ROM version. (E.g. TC35661-501: 115,2kbps)

#### 6.3.2 Connection Example

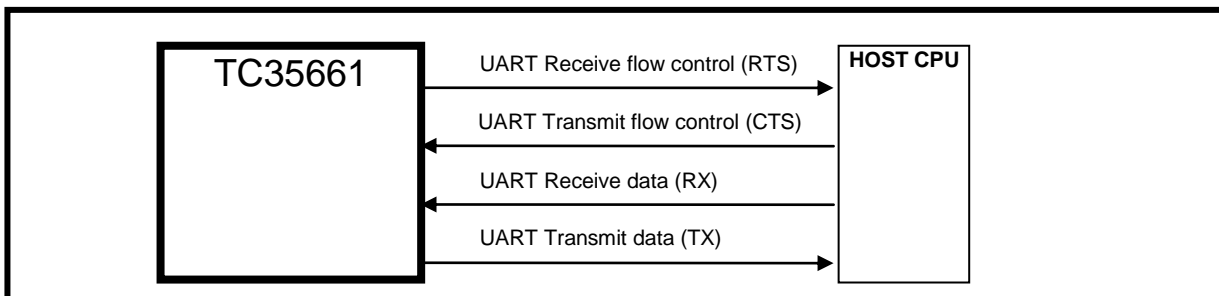

UART connection example

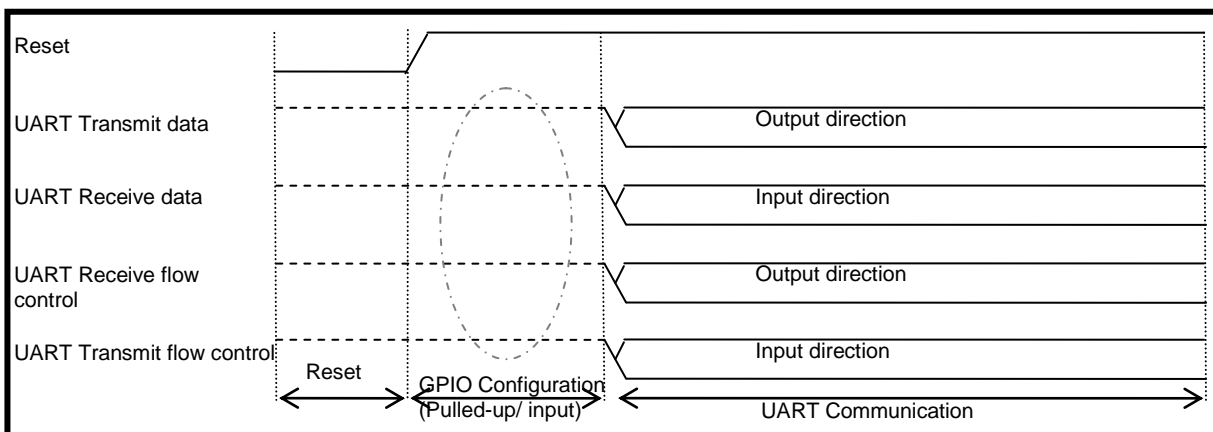

Power-up sequence for UART configuration

CLASSIFICATION	PRODUCT SPECIFICATION	No. DS-1026-2400-102	REV. 1.9
SUBJECT	CLASS 2 BLUETOOTH LOW ENERGY SPP MODULE	PAGE	12 of 35
CUSTOMER'S CODE PAN1026	PANASONIC'S CODE ENW89837AxKF	DATE	16.06.2017

### 6.3.3 Frame Format

TC35661 supporting format is as follows.

- Number of data bits: 8 bits
- Parity bit: no parity
- Stop bit: 1 stop bit
- Flow control: RTS/CTS

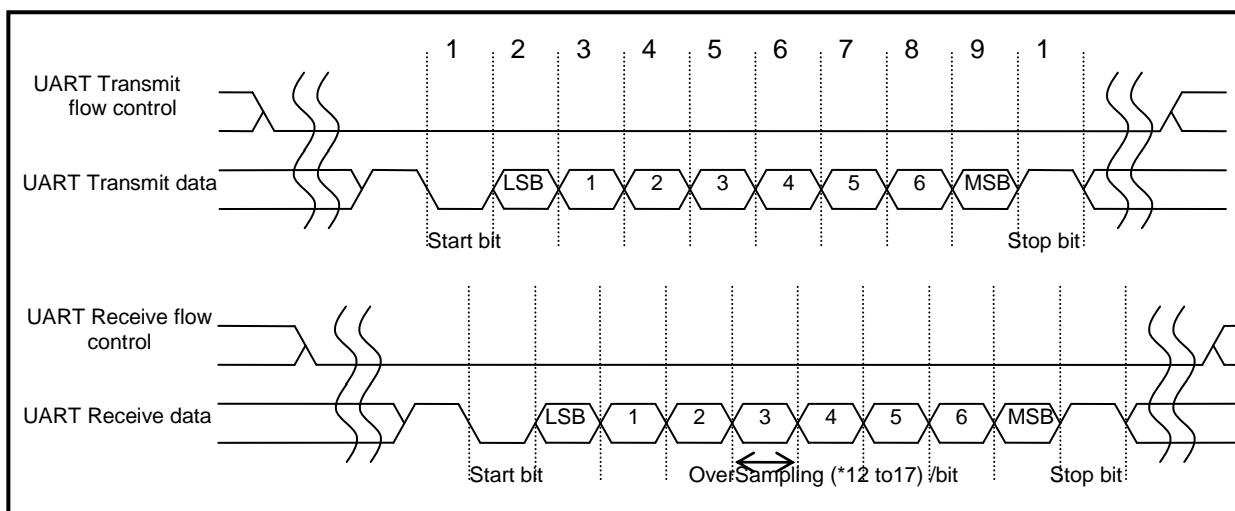

UART data frame

### 6.3.4 Flow Control Function

TC35661 UART interface uses flow control function by hardware signal, Transmit flow control (CTS<sub>X</sub>) and receive flow control (RTS<sub>X</sub>). Above Figure shows signals input and output direction.

CTS<sub>X</sub> input signal is used for UART transmitting. Low input indicates close of the preparation of the other party to receive data and TC35661 executes UART transmitting data if there is data for transmission. In case of input high level, TC35661 stops transmitting by UART frame.

RTS<sub>X</sub> input signal is used for UART receiving. Low output indicates request data transmission to UART transmit side device of the other party. TC35661 outputs Low level from RTS<sub>X</sub> when being able to receive data and prepares to receive data.

Response time of UART transmitting and receiving for flow control signal depends on baud rate and internal process status of frame. It is from 1 frame to 4 frames.

CLASSIFICATION	PRODUCT SPECIFICATION	No. DS-1026-2400-102	REV. 1.9
SUBJECT	CLASS 2 BLUETOOTH LOW ENERGY SPP MODULE	PAGE	13 of 35
CUSTOMER'S CODE PAN1026	PANASONIC'S CODE ENW89837AxKF	DATE	16.06.2017

### 6.3.5 UART Baud Rate Setting

TC35661 UART interface has a programmable baud rate setting function. The UART baud rate can be set according to the following equation. The baud rate generating clock frequency is set to either 39 MHz or 52 MHz. The over-sampling number is set to an integer that ranges from 12 to 17. The dividing ratio is set to an integer that ranges from 1 to 65,535.

$$UART\ BaudRate = \frac{Baud\ Rate\ Generating\ Clock\ Frequency}{Over\ Sampling\ Number \times Dividing\ Ratio}$$

Table 6-1 shows examples of UART Baud rate setting. The maximum of the actual baud rate is 4,333,333 [bps]. If other target baud rates are required, please contact our engineering department.

**Table 6-1 UART Baud rate setting**

Target baud rate [bps]	Actual baud rate [bps]	Baud rate generating clock frequency [MHz]	Over-sampling number	Dividing ratio	Deviation [%]
115,200	116,071	39	12	28	+0.7564
115,200	116,071	52	14	32	+0.7564
921,600	928,571	39	14	3	+0.7564
921,600	928,571	52	14	4	+0.7564
1,843,200	1,875,143	52	14	2	+0.7564
2,764,800	2,785,714	39	14	1	+0.7564
4,329,600	4,333,333	52	12	1	+0.0862

### 6.3.6 Error Detect Function

TC35661 UART interface has 3 kinds of error functions.

- Receiver timeout error
- Receiver over run error
- Receiver frame error

Receiver timeout error reports as an error if the receiver frame interval counted by TC35661 internal timer is equal to or greater than a predetermined time

Receiver over run error is reported if UART internal receive frame buffer TC35661 is overflowed.

Receiver frame error is reported if it fails to recognize the unit frame.

CLASSIFICATION	PRODUCT SPECIFICATION	No. DS-1026-2400-102	REV. 1.9
SUBJECT	CLASS 2 BLUETOOTH LOW ENERGY SPP MODULE	PAGE	14 of 35
CUSTOMER'S CODE PAN1026	PANASONIC'S CODE ENW89837AxKF	DATE	16.06.2017

## 7 BLUETOOTH FEATURES

- Bluetooth 4.0 with SPP & GATT
- GAP support for SPP
- GATT Server and Client Mode are supported for LE
- Class 2 TX power w/o external PA, improving link robustness.
- Excellent link budget (up to 91 dB), enabling long-range applications.
- GAP peripheral support for LE

### Note:

- For GAP Broadcaster and Peripheral role are supported
- Observer and Central is not supported on GAP
- For GATT Server and Client Mode are supported

## 8 BLOCK DIAGRAM

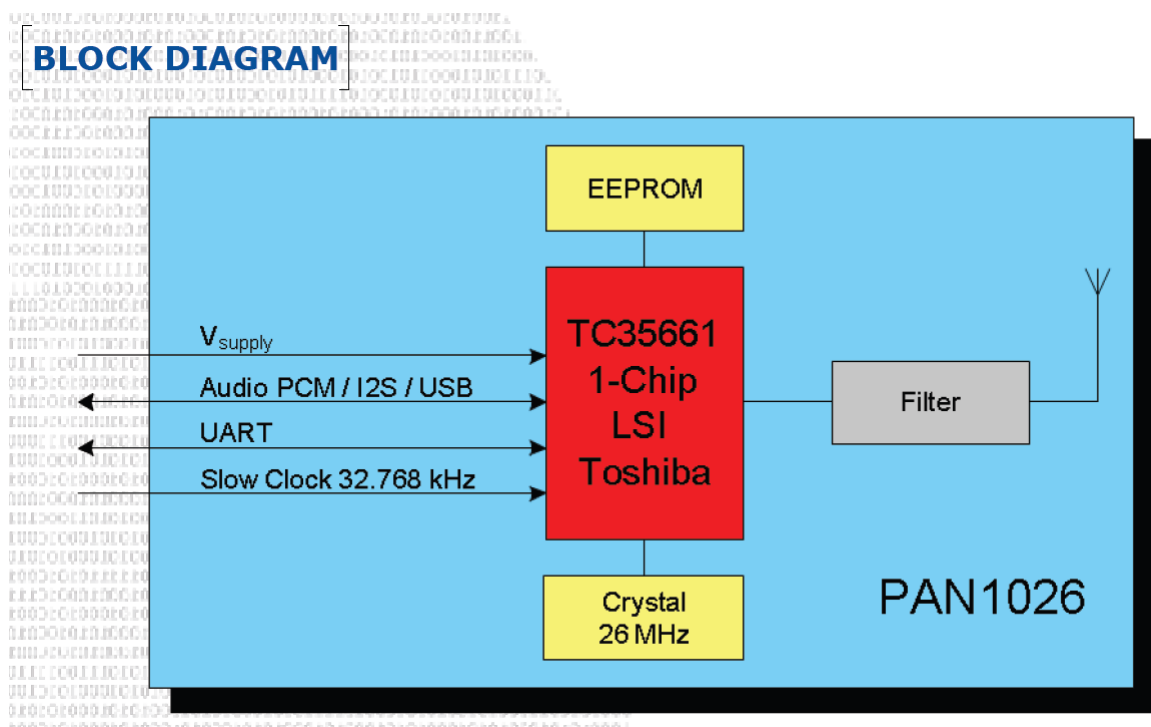

The total Capacitor value is 6.7 $\mu$ F +/-10%.

The total Inductance is 2nH +/-10%.

The total Resistance is 220k $\Omega$  +/-10%.

CLASSIFICATION	PRODUCT SPECIFICATION	No. DS-1026-2400-102	REV. 1.9
SUBJECT	CLASS 2 BLUETOOTH LOW ENERGY SPP MODULE	PAGE	15 of 35
CUSTOMER'S CODE PAN1026	PANASONIC'S CODE ENW89837AxKF	DATE	16.06.2017

## 9 TEST CONDITIONS

Measurements shall be made under operating free-air temperature range unless otherwise specified.

Temperature	25 ± 10°C
Humidity	40 to 85%RH
Supply Voltage	3.3V

## 10 GENERAL DEVICE REQUIREMENTS AND OPERATION

All specifications are over temperature and process, unless indicated otherwise.

### 10.1 ABSOLUTE MAXIMUM RATINGS

No	See <sup>2</sup>	Value	Unit
Ratings Over Operating Free-Air Temperature Range			
1	Voltage on any digital pin	-0.3 to VDD+0.3	V
2	Operating ambient temperature range	-40 to 85	°C
3	Storage temperature range	-40 to 125	°C
4	Bluetooth RF inputs	10	dBm
5	ESD: All pads, according to human-body model, JEDEC STD 22, method A114 According to charged-device model, JEDEC STD 22, method C101	1000 500	V

### 10.2 RECOMMENDED OPERATING CONDITIONS

No	Rating	Min	Typ	Max	Unit
1	Power supply voltage	2.7	3.3	3.6	V
2	Maximum ambient operating temperature		-40	85	°C

<sup>2</sup> Stresses beyond those listed under "absolute maximum ratings" may cause permanent damage to the device. These are stress ratings only and functional operation of the device at these or any other conditions beyond those indicated under "recommended operating conditions" is not implied. Exposure to absolute-maximum-rated conditions for extended periods may affect device reliability.

CLASSIFICATION	PRODUCT SPECIFICATION	No. DS-1026-2400-102	REV. 1.9
SUBJECT	CLASS 2 BLUETOOTH LOW ENERGY SPP MODULE	PAGE	16 of 35
CUSTOMER'S CODE PAN1026	PANASONIC'S CODE ENW89837AxKF	DATE	16.06.2017

### 10.3 CURRENT CONSUMPTION

The current consumption is dependent on the user scenario and the setup and timing in the low power modes.

Characteristics	Condition	Min	Typ	Max	Unit
Idle Current	After reset was pulled down.		7.8		mA
Connected Peak Power	Sending DH5 packets. Max. output power.			62	mA
Connected Peak Power	Sending DH3 packets. Max. output power.			61	mA
Connected Peak Power	Sending DH1 packets. Max. output power.			55	mA
Sniff Mode	Sniff Interval =1280ms Attempt =4 Timeout=0		0.18		mA
Sniff Mode	Sniff Interval =500ms Attempt =4 Timeout=0		0.41		mA
Paging	PageScan interval=1280ms window=11ms		0.33		mA
Inquiry	InquiryScan interval=1280ms window=11ms		0.33		mA
BLE Advertising (1 Packet)	Advertising interval=30ms		5.8		mA
BLE Advertising (1 Packet)	Advertising interval=1280ms		0.165		mA
BLE Connected (1 Packet)	Connection interval=105ms		0.913		mA
BLE Connected (1 Packet)	Connection interval=1000ms		0.123		mA

## 11 BLUETOOTH RF PERFORMANCE

### 11.1 BLUETOOTH CHARACTERISTICS

No	Characteristics	Condition	Min	Typ	Max	BT Spec	Unit
1	Operation frequency range		2402		2480		MHz
2	Channel spacing	BT-Classic/BLE		1/2			MHz
3	Output Power	Maximum setting, measured at dual ended 50ohm.		4			dBm
4	Sensitivity			-88			dBm

No	Characteristics	Condition	Typ	Max	Unit
1	Spurious emissions	Conducted measurement with a 50-Ω dual-ended load. Complies with EN 300 328, EN 300 440 class 2, FCC CFR47, Part 15 and ARIB STD-T-66	<-30		dBm



CLASSIFICATION	PRODUCT SPECIFICATION	No. DS-1026-2400-102	REV. 1.9
SUBJECT	CLASS 2 BLUETOOTH LOW ENERGY SPP MODULE	PAGE	17 of 35
CUSTOMER'S CODE PAN1026	PANASONIC'S CODE ENW89837AxKF	DATE	16.06.2017

## 12 SOLDERING TEMPERATURE-TIME PROFILE (FOR REFLOW SOLDERING)

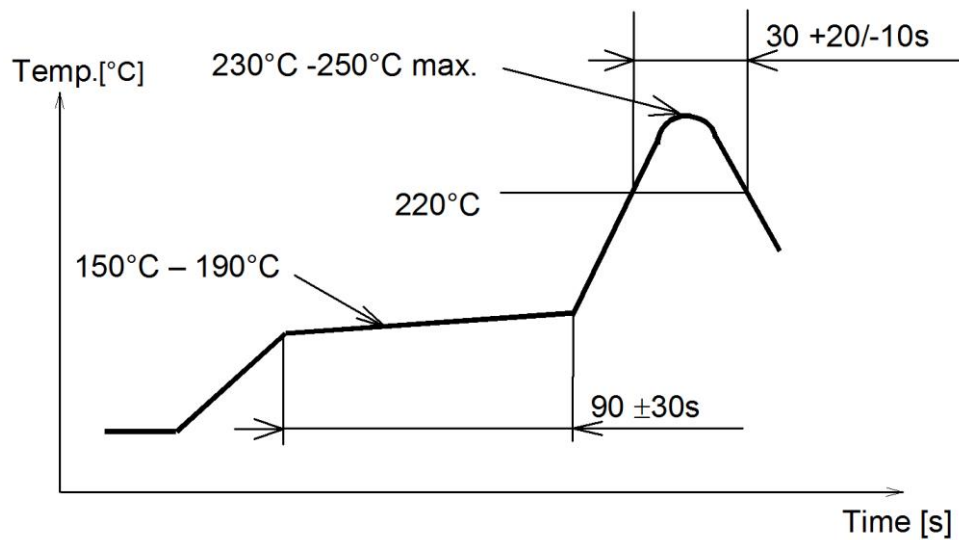

Reflow permissible cycle: 2  
 Opposite side reflow is prohibited due to module weight.

CLASSIFICATION	PRODUCT SPECIFICATION	No. DS-1026-2400-102	REV. 1.9
SUBJECT	CLASS 2 BLUETOOTH LOW ENERGY SPP MODULE	PAGE	18 of 35
CUSTOMER'S CODE PAN1026	PANASONIC'S CODE ENW89837AxKF	DATE	16.06.2017

### 13 MODULE DIMENSION

No.	Item	Dimension	Tolerance	Remark
1	Width	8.70	$\pm 0.20$	
2	Length	15.60	$\pm 0.20$	
3	Height	1.80	$\pm 0.20$	With case

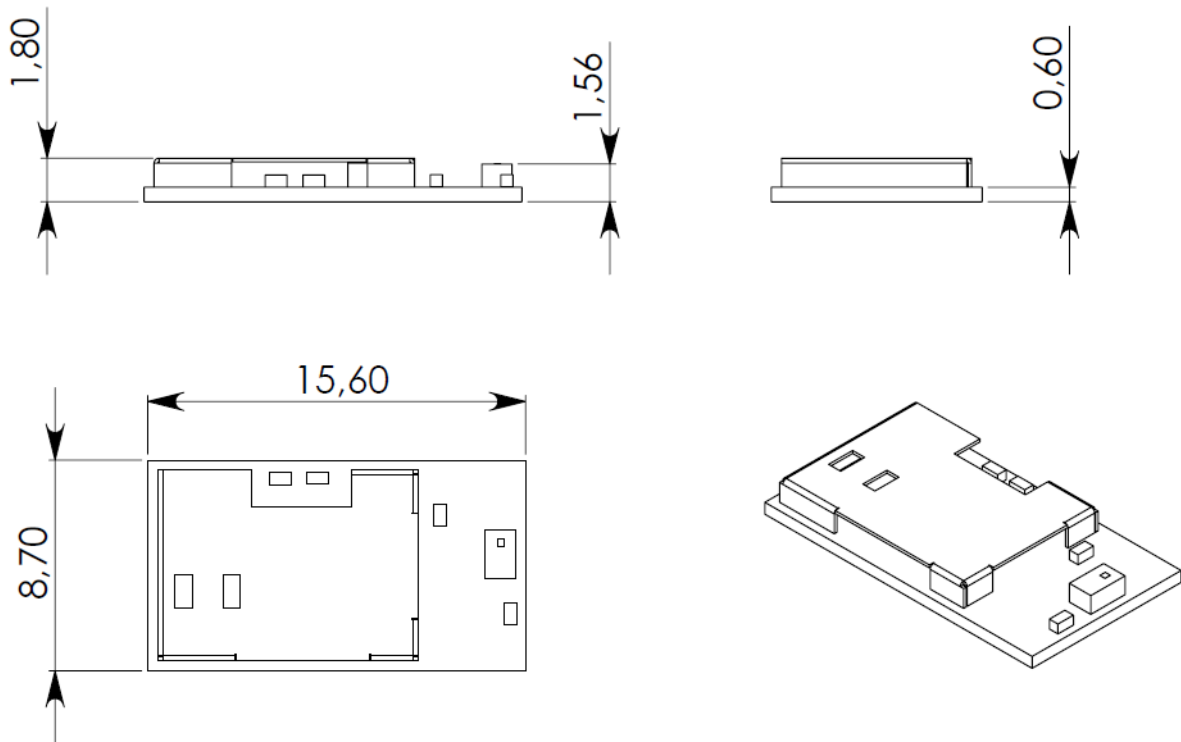

CLASSIFICATION	PRODUCT SPECIFICATION	No. DS-1026-2400-102	REV. 1.9
SUBJECT	CLASS 2 BLUETOOTH LOW ENERGY SPP MODULE	PAGE	19 of 35
CUSTOMER'S CODE PAN1026	PANASONIC'S CODE ENW89837AxKF	DATE	16.06.2017

## 14 PAN1026 FOOTPRINT OF THE MODULE

All dimensions are in millimeters.  
The outer dimensions have a tolerance of  $\pm 0.2\text{mm}$ .

Top view, Application PCB

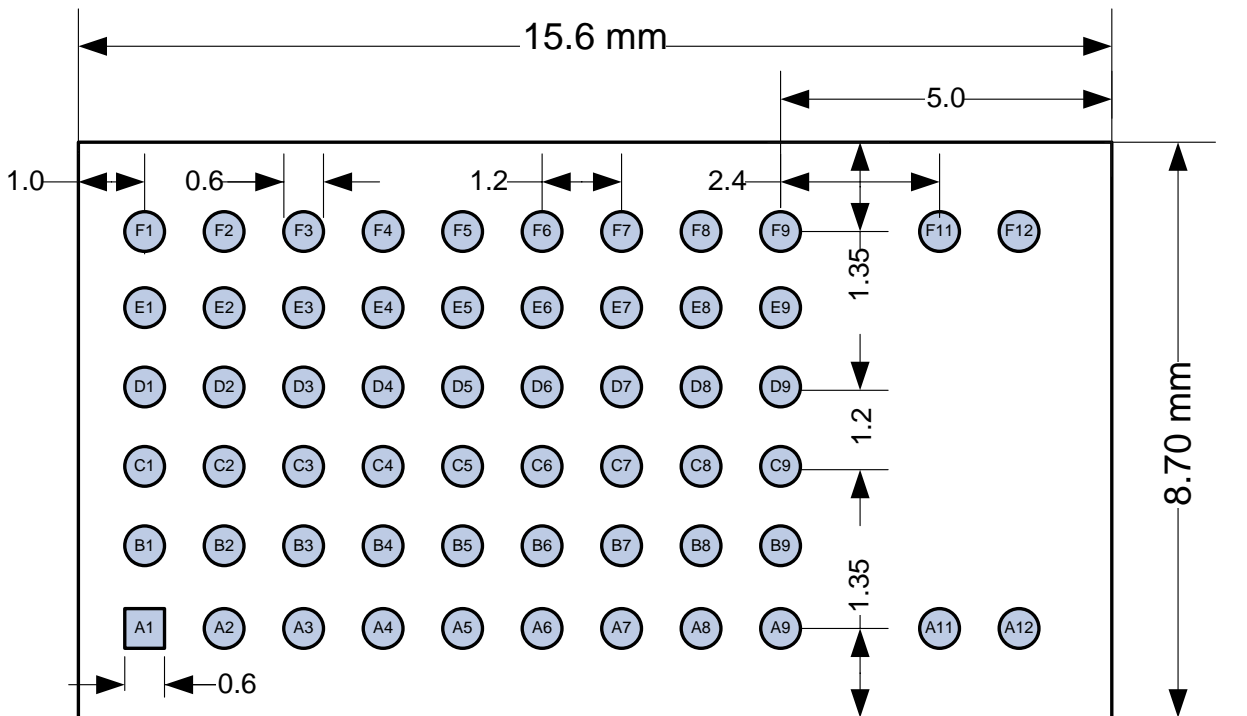

CLASSIFICATION	PRODUCT SPECIFICATION	No. DS-1026-2400-102	REV. 1.9
SUBJECT	CLASS 2 BLUETOOTH LOW ENERGY SPP MODULE	PAGE	20 of 35
CUSTOMER'S CODE PAN1026	PANASONIC'S CODE ENW89837AxKF	DATE	16.06.2017

## 15 CASE MARKING

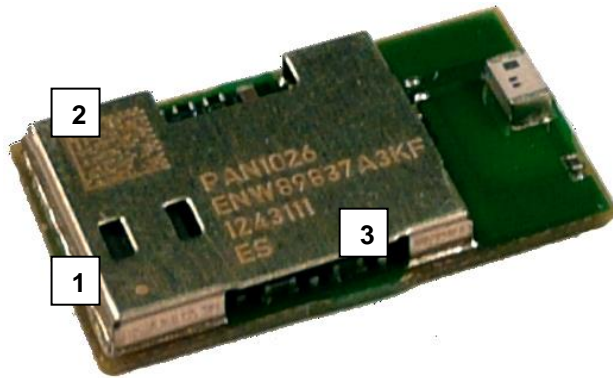

No.	Remark
1	Marking for Pin 1 (Circle 0,15 mm)
2	2D-Code, for internal usage only and can be change without any notice
3	Marking definition see chapter 15.1

### 15.1 EXAMPLE FOR MARKING

P	A	N	1	0	2	6			H	W	/	S	W			
E	N	W	8	9	8	3	7	A	3	K	F					
Y	Y	W	W	D	L	L										
F	C	C	I	D	:		T	7	V	P	A	N	1	0		

### 15.2 MARKING DEFINITION

(1) Pin1 marking

(2) 2D code (Serial number)

(3) Marking:

PAN1026 (Model Name), HW/SW (Hardware/Software version)

ENW89837AxKF (Part Number, refer to chapter 20 Ordering Information)

Lot code (YearYear, WeekWeek, Day, LotLot)

ES (Engineering Sample marking)

## 16 MECHANICAL REQUIREMENTS

No.	Item	Limit	Condition
1	Solderability	More than 75% of the soldering area shall be coated by solder	Reflow soldering with recommendable temperature profile
2	Resistance to soldering heat	It shall be satisfied electrical requirements and not be mechanical damage	

CLASSIFICATION	PRODUCT SPECIFICATION	No. DS-1026-2400-102	REV. 1.9
SUBJECT	CLASS 2 BLUETOOTH LOW ENERGY SPP MODULE	PAGE	21 of 35
CUSTOMER'S CODE PAN1026	PANASONIC'S CODE ENW89837AxKF	DATE	16.06.2017

## 17 RELIABILITY TESTS

The measurement should be done after being exposed to room temperature and humidity for 1 hour.

No.	Item	Limit	Condition
1	Vibration test	Electrical parameter should be in specification	a) Freq.:10~50Hz,Amplitude:1.5mm a) 20min. / cycle,1hrs. each of XYZ axis b) Freq.:30~100Hz, 6G b) 20min. / cycle,1hrs. each of XYZ axis
2	Shock test	the same as above	Dropped onto hard wood from height of 50cm for 3 times
3	Heat cycle test	the same as above	-40°C for 30min. and +85°C for 30min.; each temperature 300 cycles
4	Moisture test	the same as above	+60°C, 90% RH, 300h
5	Low temp. test	the same as above	-40°C, 300h
6	High temp. test	the same as above	+85°C, 300h

CLASSIFICATION	PRODUCT SPECIFICATION	No. DS-1026-2400-102	REV. 1.9
SUBJECT	CLASS 2 BLUETOOTH LOW ENERGY SPP MODULE	PAGE	22 of 35
CUSTOMER'S CODE PAN1026	PANASONIC'S CODE ENW89837AxKF	DATE	16.06.2017

## 18 CAUTIONS

Failure to follow the guidelines set forth in this document may result in degrading of the product's functions and damage to the product.

### 18.1 DESIGN NOTES

- (1) Follow the conditions written in this specification, especially the control signals of this module.
- (2) The supply voltage has to be free of AC ripple voltage (for example from a battery or a low noise regulator output). For noisy supply voltages, provide a decoupling circuit (for example a ferrite in series connection and a bypass capacitor to ground of at least 47uF directly at the module).
- (3) This product should not be mechanically stressed when installed.
- (4) Keep this product away from heat. Heat is the major cause of decreasing the life of these products.
- (5) Avoid assembly and use of the target equipment in conditions where the products' temperature may exceed the maximum tolerance.
- (6) The supply voltage should not be exceedingly high or reversed. It should not carry noise and/or spikes.
- (7) Keep this product away from other high frequency circuits.

### 18.2 INSTALLATION NOTES

- (1) Reflow soldering is possible twice based on the conditions in chapter 12. Set up the temperature at the soldering portion of this product according to this reflow profile.
- (2) Carefully position the products so that their heat will not burn into printed circuit boards or affect the other components that are susceptible to heat.
- (3) Carefully locate these products so that their temperatures will not increase due to the effects of heat generated by neighboring components.
- (4) If a vinyl-covered wire comes into contact with the products, then the cover will melt and generate toxic gas, damaging the insulation. Never allow contact between the cover and these products to occur.
- (5) This product should not be mechanically stressed or vibrated when reflowed.
- (6) If you want to repair your board by hand soldering, please keep the conditions of this chapter.
- (7) Do not wash this product.
- (8) Refer to the recommended pattern when designing a board.
- (9) Pressing on parts of the metal cover or fastening objects to the metal will cause damage to the unit.
- (10) For more details on LGA (Land Grid Array) soldering processes refer to the application note.

CLASSIFICATION	PRODUCT SPECIFICATION	No. DS-1026-2400-102	REV. 1.9
SUBJECT	CLASS 2 BLUETOOTH LOW ENERGY SPP MODULE	PAGE	23 of 35
CUSTOMER'S CODE PAN1026	PANASONIC'S CODE ENW89837AxKF	DATE	16.06.2017

### 18.3 USAGE CONDITIONS NOTES

- (1) Take measures to protect the unit against static electricity.  
If pulses or other transient loads (a large load applied in a short time) are applied to the products, check and evaluate their operation before assembly on the final products.
- (2) Do not use dropped products.
- (3) Do not touch, damage or soil the pins.
- (4) Follow the recommended condition ratings about the power supply applied to this product.
- (5) Electrode peeling strength: Do not add pressure of more than 4.9N when soldered on PCB.
- (6) Pressing on parts of the metal cover or fastening objects to the metal cover will cause damage.
- (7) These products are intended for general purpose and standard use in general electronic equipment, such as home appliances, office equipment, information and communication equipment.

### 18.4 STORAGE NOTES

- (1) The module should not be stressed mechanically during storage.
- (2) Do not store these products in the following conditions or the performance characteristics of the product, such as RF performance will be adversely affected:
  - Storage in salty air or in an environment with a high concentration of corrosive gas, such as Cl<sub>2</sub>, H<sub>2</sub>S, NH<sub>3</sub>, SO<sub>2</sub>, or NO<sub>x</sub>
  - Storage in direct sunlight
  - Storage in an environment where the temperature may be outside the range of 5°C to 35°C range, or where the humidity may be outside the 45 to 85% range.
  - Storage of the products for more than one year after the date of delivery Storage period: Please check the adhesive strength of the embossed tape and soldering after 6 months of storage.
- (3) Keep this product away from water, poisonous gas and corrosive gas.
- (4) This product should not be stressed or shocked when transported.
- (5) Follow the specification when stacking packed crates (max. 10).

### 18.5 SAFETY CAUTIONS

These specifications are intended to preserve the quality assurance of products and individual components.

Before use, check and evaluate the operation when mounted on your products. Abide by these specifications, without deviation when using the products. These products may short-circuit. If electrical shocks, smoke, fire, and/or accidents involving human life are anticipated when a short circuit occurs, then provide the following failsafe functions, as a minimum.

- (1) Ensure the safety of the whole system by installing a protection circuit and a protection device.
- (2) Ensure the safety of the whole system by installing a redundant circuit or another system to prevent a dual fault causing an unsafe status.

CLASSIFICATION	PRODUCT SPECIFICATION	No. DS-1026-2400-102	REV. 1.9
SUBJECT	CLASS 2 BLUETOOTH LOW ENERGY SPP MODULE	PAGE	24 of 35
CUSTOMER'S CODE PAN1026	PANASONIC'S CODE ENW89837AxKF	DATE	16.06.2017

## 18.6 OTHER CAUTIONS

- (1) This specification sheet is copyrighted. Reproduction of this data sheets is permissible only if reproduction is without alteration and is accompanied by all associated warranties, conditions, limitations, and notices.
- (2) Do not use the products for other purposes than those listed.
- (3) Be sure to provide an appropriate fail-safe function on your product to prevent an additional damage that may be caused by the abnormal function or the failure of the product.
- (4) This product has been manufactured without any ozone chemical controlled under the Montreal Protocol.
- (5) These products are not intended for other uses, other than under the special conditions shown below. Before using these products under such special conditions, check their performance and reliability under the said special conditions carefully to determine whether or not they can be used in such a manner.
  - In liquid, such as water, salt water, oil, alkali, or organic solvent, or in places where liquid may splash.
  - In direct sunlight, outdoors, or in a dusty environment
  - In an environment where condensation occurs.
  - In an environment with a high concentration of harmful gas (e.g. salty air, HCl, Cl<sub>2</sub>, SO<sub>2</sub>, H<sub>2</sub>S, NH<sub>3</sub>, and NO<sub>x</sub>)
- (6) If an abnormal voltage is applied due to a problem occurring in other components or circuits, replace these products with new products because they may not be able to provide normal performance even if their electronic characteristics and appearances appear satisfactory.
- (7) When you have any question or uncertainty, contact Panasonic.

## 18.7 LIFE SUPPORT POLICY

This Panasonic Industrial Devices Europe GmbH product is not designed for use in life support appliances, devices, or systems where malfunction can reasonably be expected to result in a significant personal injury to the user, or as a critical component in any life support device or system whose failure to perform can be reasonably expected to cause the failure of the life support device or system, or to affect its safety or effectiveness.

Panasonic customers using or selling these products for use in such applications do so at their own risk and agree to fully indemnify Panasonic Industrial Devices Europe GmbH for any damages resulting.



CLASSIFICATION	PRODUCT SPECIFICATION	No. DS-1026-2400-102	REV. 1.9
SUBJECT	CLASS 2 BLUETOOTH LOW ENERGY SPP MODULE	PAGE	25 of 35
CUSTOMER'S CODE PAN1026	PANASONIC'S CODE ENW89837AxKF	DATE	16.06.2017

## 19 PACKAGING

If the product has mass production status, we will deliver the module in the package which is described below.

### 19.1 TAPE DIMENSION

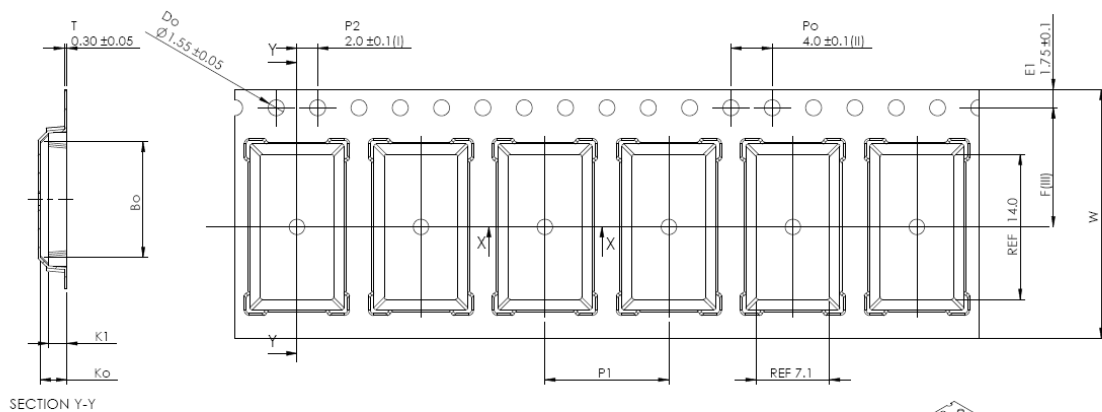

A o	9.10	+/- 0.1
B o	16.00	+/- 0.1
K o	3.20	+/- 0.1
K 1	2.20	+/- 0.1
F	11.50	+/- 0.1
P 1	12.00	+/- 0.1
W	24.00	+/- 0.3

Forming format : Flatbed  
Estimated max. length : 64 meter/22B3 reel

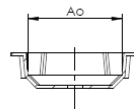

- (I) Measured from centreline of sprocket hole to centreline of pocket.
- (II) Cumulative tolerance of 10 sprocket holes is  $\pm 0.20$ .
- (III) Measured from centreline of sprocket hole to centreline of pocket.
- (IV) Other material available.

ALL DIMENSIONS IN MILLIMETRES UNLESS OTHERWISE STATED.

### 19.2 PACKING IN TAPE

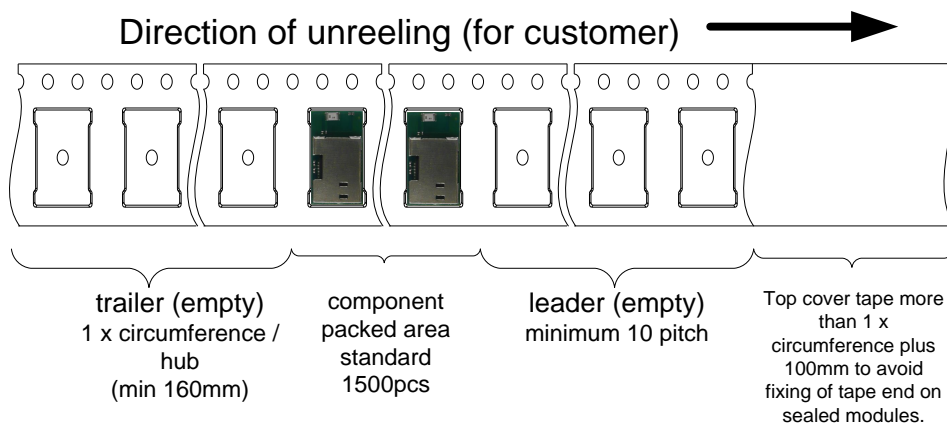

Empty spaces in component packed area shall be less than two per reel and those spaces shall not be consecutive.

Top cover tape shall not be found on reel holes and shall not stick out from reel.

CLASSIFICATION	PRODUCT SPECIFICATION	No. DS-1026-2400-102	REV. 1.9
SUBJECT	CLASS 2 BLUETOOTH LOW ENERGY SPP MODULE	PAGE	26 of 35
CUSTOMER'S CODE PAN1026	PANASONIC'S CODE ENW89837AxKF	DATE	16.06.2017

### 19.3 COMPONENT DIRECTION

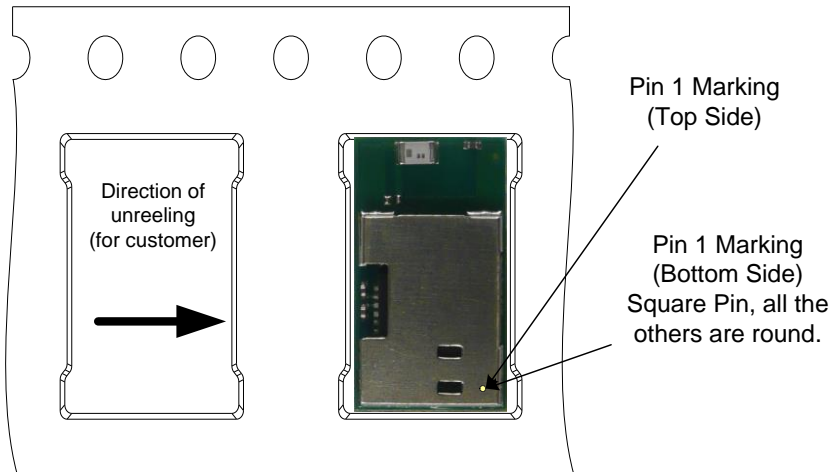

### 19.4 REEL DIMENSION

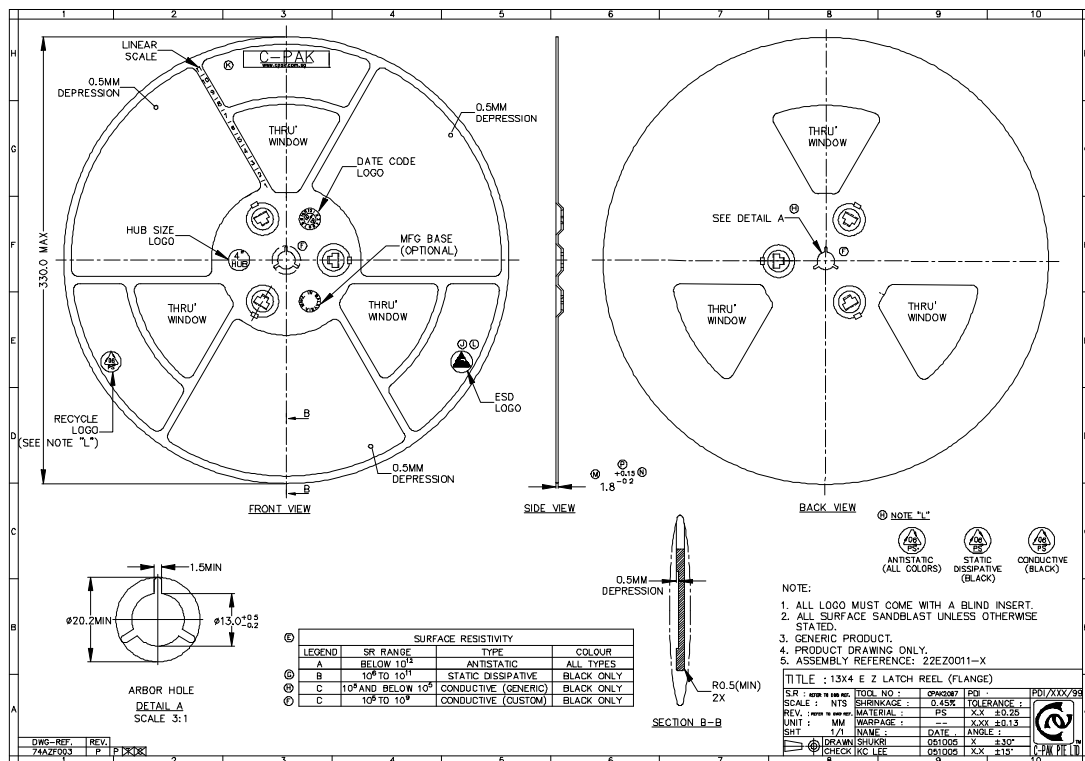

CLASSIFICATION	PRODUCT SPECIFICATION	No. DS-1026-2400-102	REV. 1.9
SUBJECT	CLASS 2 BLUETOOTH LOW ENERGY SPP MODULE	PAGE	27 of 35
CUSTOMER'S CODE PAN1026	PANASONIC'S CODE ENW89837AxKF	DATE	16.06.2017

## 19.5 LABEL FOR PACKAGE

The picture shows an example from similar product.

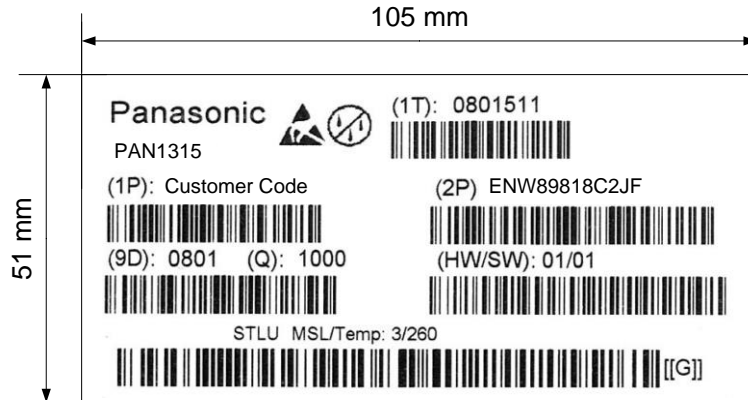

(1T)	Lot code [YYWWDLL]	Example from above:
	YY year	printed 08
	WW normal calendar week	printed 01
	D day	printed 5 (Friday)
	L line identifier, if more as one	printed 1
	L lot identifier per day	printed 1
(1P)	Customer Order Code, if any, otherwise company name will be printed	
(2P)	Panasonic Order Code: ENW89837AxKF	
(9D)	Date code as [YYWW]	
(Q)	Quantity [XXXX], variable max. 1500	
(HW/SW)	Hardware /Software Release	
	Hardware 01 Indicates the HW revision.	
	Software 01 Indicates the SW revision.	

## 19.6 TOTAL PACKAGE

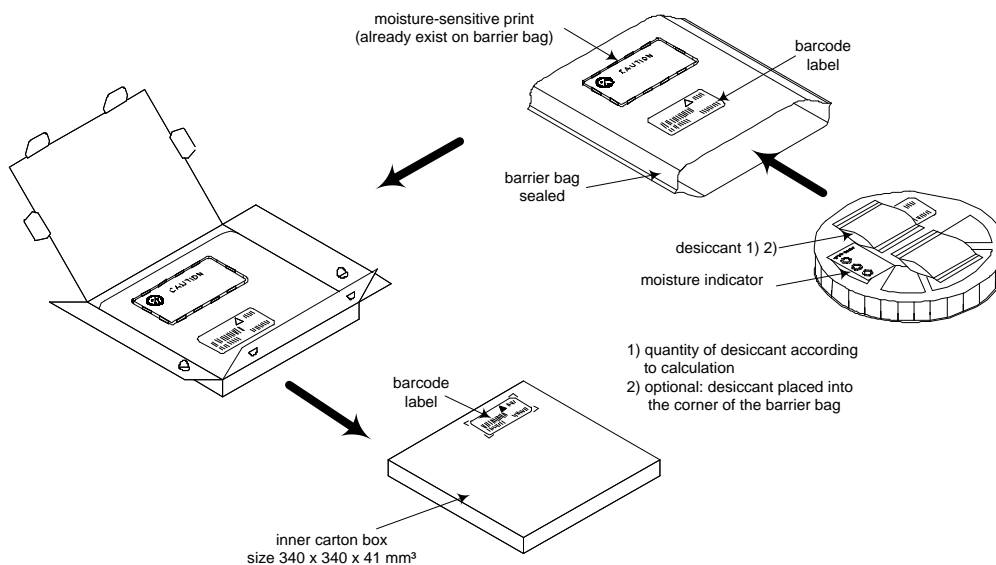

CLASSIFICATION	PRODUCT SPECIFICATION	No. DS-1026-2400-102	REV. 1.9
SUBJECT	CLASS 2 BLUETOOTH LOW ENERGY SPP MODULE	PAGE	28 of 35
CUSTOMER'S CODE PAN1026	PANASONIC'S CODE ENW89837AxKF	DATE	16.06.2017

## 20 ORDERING INFORMATION

Ordering part number	Description	MOQ <sup>(1)</sup>
ENW89837A3KF <sup>(2)</sup>	PAN1026 CLASS 2 Bluetooth dual mode Module according BT-4.0. 115kBaud Standard <i>Bluetooth</i> ® smart ready device	1500
ENW89837A8KF	PAN1026 CLASS 2 Bluetooth dual mode Module according BT-4.0. 9k6Baud <i>Bluetooth</i> ® smart ready device	1500

### Notes:

- (1) Abbreviation for Minimum Order Quantity (MOQ). The standard MOQ for mass production is 1500 pieces, fewer only on customer demand. Samples for evaluation can be delivered at any quantity via the distribution channels.
- (2) Samples are available on customer demand

## 21 ROHS AND REACH DECLARATION

The latest declaration of environmental compatibility (RoHS and REACH) for supplied products can be found on the Panasonic website in the "Downloads" section of the respective product.

Please also refer to chapter 1.3.

CLASSIFICATION	PRODUCT SPECIFICATION	No. DS-1026-2400-102	REV. 1.9
SUBJECT	CLASS 2 BLUETOOTH LOW ENERGY SPP MODULE	PAGE	29 of 35
CUSTOMER'S CODE PAN1026	PANASONIC'S CODE ENW89837AxKF	DATE	16.06.2017

## 22 SOFTWARE

### 22.1 SOFTWARE DESCRIPTION

The module software offers both embedded Bluetooth HCI (Host Control Interface), extended HCI and TCU (Toshiba Control Unit) Command interfaces via the embedded UART interface

- a) HCI commands are standard according to Bluetooth standard specifications.
- b) Extended HCI commands are available for device control, such as RF control, BD\_ADDR control, firmware version control, embedded IO control, maintenance tasks etc. Please refer to the "Extension HCI Command Document".
- c) The PAN1026 includes the Bluetooth LSI TC35661 incorporating Bluetooth stack and SPP profile and BLE GATT profile. The profile application interface is described in the "SPP Command Interface Document" (about 14 commands) and the "Bluetooth Basic Management Command Interface Document" (about 46 commands). The related high level commands are called "TCU" commands.  
The "SPP Message Sequence Chart Document" and the "Bluetooth Management Message Sequence Chart Document" describe the logical and sequential procedure to use those commands.
- d) After RESET of the module, the module starts in HCI mode. The "Bluetooth LSI TC35661 Application Note" describes how to start the device and enter into "TCU" mode thereafter.
- e) The LSI Supplier (Toshiba) offers SPP drivers, that allows a further abstraction towards the application software including SPP programming examples. This is documented in the "BT SPP API Specification", the "BT SPP Driver Specification" and the "BT SPP Application Note". The "SPP API" offers a few high-level APIs for LSI initialization, connection setup and communication with a remote SPP device. The user has full control over all LSI features by utilizing the lower-level "SPP Drivers". The drivers take care for issuing commands and data to the LSI and they handle the responses from the TC36661. The "Application Note" includes a SPP programming example and shows the integration with a RTOS."

All documents are available on respective Panasonic or Toshiba websites.

### 22.2 SOFTWARE VERSION INFORMATION

The version number of the embedded software can be read out by an extended HCI command.

The extended HCI command class < HCI\_M2\_Message\_Get >" allows the reading of the firmware version. Pls refer to the extended HCI command list of TC35661 LSI.

CLASSIFICATION	PRODUCT SPECIFICATION	No. DS-1026-2400-102	REV. 1.9
SUBJECT	CLASS 2 BLUETOOTH LOW ENERGY SPP MODULE	PAGE	30 of 35
CUSTOMER'S CODE PAN1026	PANASONIC'S CODE ENW89837AxKF	DATE	16.06.2017

### 22.3 SOFTWARE BLOCK DIAGRAM

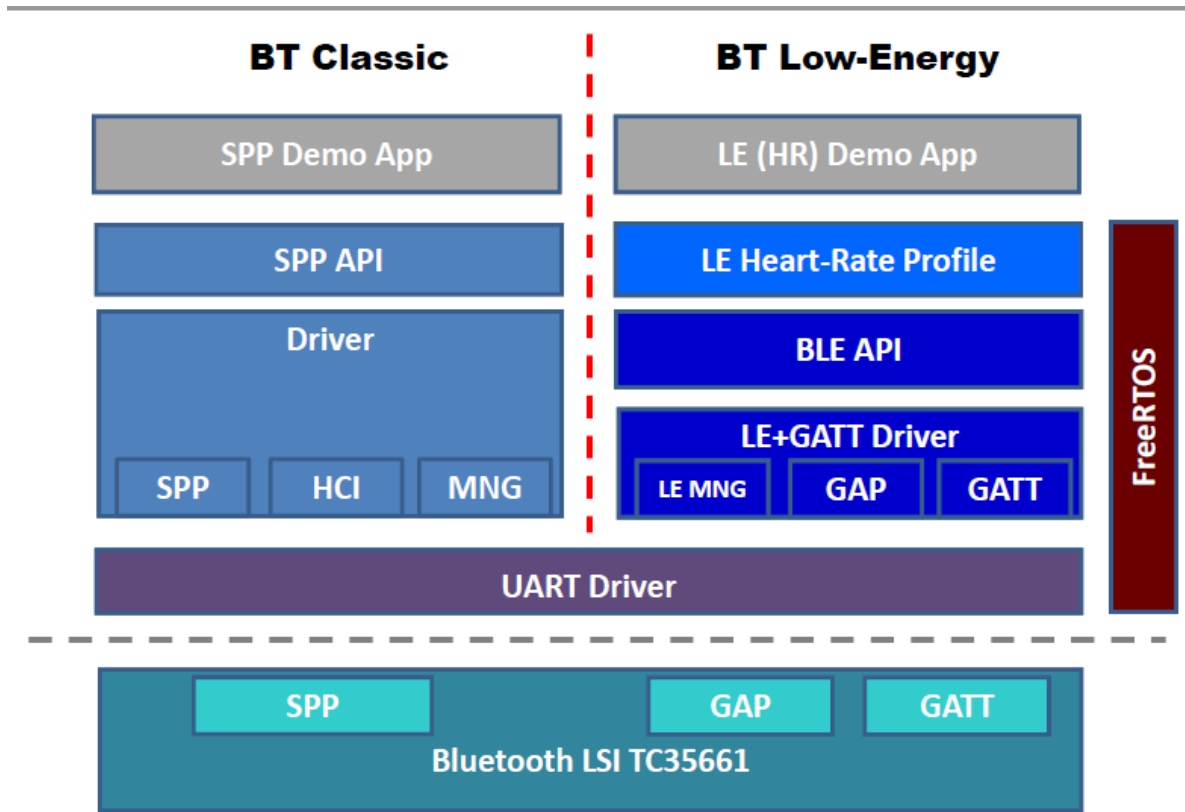

CLASSIFICATION	PRODUCT SPECIFICATION	No. DS-1026-2400-102	REV. 1.9
SUBJECT	CLASS 2 BLUETOOTH LOW ENERGY SPP MODULE	PAGE	31 of 35
CUSTOMER'S CODE PAN1026	PANASONIC'S CODE ENW89837AxKF	DATE	16.06.2017

## 23 REGULATORY INFORMATION

### 23.1 FCC FOR US

#### 23.1.1 FCC Notice



The devices PAN1026, for details refer to Chapter 20, including the antennas, which are listed in 23.1.5, complies with Part 15 of the FCC Rules. The device meets the requirements for modular transmitter approval as detailed in FCC public Notice DA00-1407.transmitter Operation is subject to the following two conditions: (1) This device may not cause harmful interference, and (2) This device must accept any interference received, including interference that may cause undesired operation.

#### 23.1.2 Caution



The FCC requires the user to be notified that any changes or modifications made to this device that are not expressly approved by Panasonic Industrial Devices Europe GmbH may void the user's authority to operate the equipment.

This equipment has been tested and found to comply with the limits for a Class B digital device, pursuant to Part 15 of the FCC Rules. These limits are designed to provide reasonable protection against harmful interference in a residential installation. This equipment generates uses and can radiate radio frequency energy and, if not installed and used in accordance with the instructions, may cause harmful interference to radio communications. However, there is no guarantee that interference will not occur in a particular installation. If this equipment does cause harmful interference to radio or television reception, which can be determined by turning the equipment off and on, the user is encouraged to try to correct the interference by one or more of the following measures:

- Reorient or relocate the receiving antenna.
- Increase the separation between the equipment and receiver.
- Connect the equipment into an outlet on a circuit different from that to which the receiver is connected.
- Consult the dealer or an experienced radio/TV technician for help

#### 23.1.3 Labeling Requirements



The Original Equipment Manufacturer (OEM) must ensure that FCC labelling requirements are met. This includes a clearly visible label on the outside of the OEM enclosure specifying the appropriate Panasonic FCC identifier for this product as well as the FCC Notice above.

The FCC identifier is **FCC ID: T7VPAN10**. This FCC identifier is valid for all PAN1026 modules, for details, see the Chapter 20 - Ordering Information.

In any case the end product must be labelled exterior with "Contains FCC ID: T7VPAN10"

#### 23.1.4 Antenna Warning



For the related part number of PAN1026 refer to Chapter 20 - Ordering Information.

This device is tested with a standard SMA connector and with the antennas listed below. When integrated in the OEMs product, these fixed antennas require installation preventing end-users from replacing them with non-approved antennas. Any antenna not in the following table must be tested to comply with FCC Section 15.203 for unique antenna connectors and Section 15.247 for emissions.

CLASSIFICATION	PRODUCT SPECIFICATION	No. DS-1026-2400-102	REV. 1.9
SUBJECT	CLASS 2 BLUETOOTH LOW ENERGY SPP MODULE	PAGE	32 of 35
CUSTOMER'S CODE PAN1026	PANASONIC'S CODE ENW89837AxKF	DATE	16.06.2017

### 23.1.5 Approved Antenna List

Note: We are able to qualify your antenna and will add to this list as that process is completed.

Item	Part Number	Manufacturer	Frequency Band	Type	Gain (dBi)
1	LDA212G3110K	Murata	2.4GHz	Chip-Antenna	+0.9
2	ANT2012LL13R2400A	Yageo	2.4G	Chip-Antenna	+0.9

### 23.1.6 RF Exposure PAN1026



To comply with FCC RF Exposure requirements, the Original Equipment Manufacturer (OEM) must ensure that the approved antenna in the previous table must be installed.

The preceding statement must be included as a CAUTION statement in manuals for products operating with the approved antennas in the previous table to alert users on FCC RF Exposure compliance.

Any notification to the end user of installation or removal instructions about the integrated radio module is not allowed.

The radiated output power of PAN1026 with mounted ceramic antenna **(FCC ID: T7VPAN10)** is far below the FCC radio frequency exposure limits. Nevertheless, the PAN1026 shall be used in such a manner that the potential for human contact during normal operation is minimized.

End users may not be provided with the module installation instructions. OEM integrators and end users must be provided with transmitter operating conditions for satisfying RF exposure compliance.



CLASSIFICATION	PRODUCT SPECIFICATION	No. DS-1026-2400-102	REV. 1.9
SUBJECT	CLASS 2 BLUETOOTH LOW ENERGY SPP MODULE	PAGE	33 of 35
CUSTOMER'S CODE PAN1026	PANASONIC'S CODE ENW89837AxKF	DATE	16.06.2017

## 23.2 INDUSTRY CANADA CERTIFICATION

PAN1026 is licensed to meet the regulatory requirements of Industry Canada (IC),  
license: IC: 216Q-PAN10

Manufacturers of mobile, fixed or portable devices incorporating this module are advised to clarify any regulatory questions and ensure compliance for SAR and/or RF exposure limits. Users can obtain Canadian information on RF exposure and compliance from [www.ic.gc.ca](http://www.ic.gc.ca).

This device has been designed to operate with the antennas listed in Table 20 above, having a maximum gain of 0.9 dBi. Antennas not included in this list or having a gain greater than 0.9 dBi are strictly prohibited for use with this device. The required antenna impedance is 50 ohms. The antenna used for this transmitter must not be co-located or operating in conjunction with any other antenna or transmitter.

Due to the model size the IC identifier is displayed in the installation instruction only and cannot be displayed on the modules label due to the limited size (8.7x15.6mm).

### 23.2.1 IC Notice



The devices PAN1026, for details refer to Chapter 20, including the antennas, which are listed in 23.1.5, complies with Canada RSS-GEN Rules. The device meets the requirements for modular transmitter approval as detailed in RSS-GEN.

Operation is subject to the following two conditions: (1) This device may not cause harmful interference, and (2) This device must accept any interference received, including interference that may cause undesired operation.

Le présent appareil est conforme aux CNR d'Industrie Canada applicables aux appareils radio exempts de licence. L'exploitation est autorisée aux deux conditions suivantes :

- (1) l'appareil ne doit pas produire de brouillage, et
- (2) l'utilisateur de l'appareil doit accepter tout brouillage radioélectrique subi, même si le brouillage est susceptible d'en compromettre le fonctionnement.

PAN1016 est garanti conforme aux dispositions réglementaires d'Industry Canada (IC), licences:  
**IC: 216Q-PAN10**

Il est recommandé aux fabricants d'appareils fixes, mobiles ou portables de consulter la réglementation en vigueur et de vérifier la conformité de leurs produits relativement aux limites d'exposition aux rayonnements radiofréquence ainsi qu'au débit d'absorption spécifique maximum autorisé.

Des informations pour les utilisateurs sur la réglementation Canadienne concernant l'exposition aux rayonnements RF sont disponibles sur le site [www.ic.gc.ca](http://www.ic.gc.ca).

Ce produit a été développé pour fonctionner spécifiquement avec les antennes listées dans le tableau ci-dessus, présentant un gain maximum de 0.9dBi. Des antennes autres que celles listées ici, ou présentant un gain supérieur à 0.9dBi ne doivent en aucune circonstance être utilisées en combinaison avec ce produit. L'impédance des antennes compatibles est 50Ohm. L'antenne utilisée avec ce produit ne doit ni être située à proximité d'une autre antenne ou d'un autre émetteur, ni être utilisée conjointement avec une autre antenne ou un autre émetteur. En raison de la taille du produit, l'identifiant IC est fourni dans le manuel d'installation.

CLASSIFICATION	PRODUCT SPECIFICATION	No. DS-1026-2400-102	REV. 1.9
SUBJECT	CLASS 2 BLUETOOTH LOW ENERGY SPP MODULE	PAGE	34 of 35
CUSTOMER'S CODE PAN1026	PANASONIC'S CODE ENW89837AxKF	DATE	16.06.2017

### 23.2.2 Labeling Requirements



The Original Equipment Manufacturer (OEM) must ensure that IC labelling requirements are met. This includes a clearly visible label on the outside of the OEM enclosure specifying the appropriate Panasonic IC identifier for this product as well as the IC Notice above.

The IC identifier is **216Q-PAN10**. This IC identifier is valid for all PAN1026 modules, for details, see the Chapter 20 - Ordering Information.

In any case the end product must be labelled exterior with "Contains **IC: 216Q-PAN10**"

#### Obligations d'étiquetage

Les fabricants d'équipements (OEM) doivent s'assurer que les obligations d'étiquetage du produit final sont remplies. Ces obligations incluent une étiquette clairement visible à l'extérieur de l'emballage externe, comportant l'identifiant IC du module Panasonic inclus, ainsi que la notification ci-dessus.

Les identifiants IC sont: **IC: 216Q-PAN10**

Ces identifiants sont valides pour tous les modules PAN1026 (Chapter 20. Ordering Information).

Dans tous les cas les produits finaux doivent indiquer sur leur emballage externe une des mentions suivantes: "**Contient IC: 216Q-PAN10**"

### 23.3 EUROPEAN CONFORMITY ACCORDING TO RED (2014/53/EU)

All modules described in this Product Specification comply with the standards according to the following LVD (2014/35/EU), EMC-D (2014/30/EU) together with the RED (2014/53/EU) articles:

3.1a Safety/Health: EN60950-1:2006+A11:2009+A1:2010+A12:2011+AC:2011+A2:2013  
EN62311:2008

3.1b EMC: EN 301 489-1 V2.1.1:2017-02  
EN 301 489-17 V3.1.1:2017-02

3.2 Radio: EN 300 328 V2.1.1:2016-11

As a result of the conformity assessment procedure described in 2014/53/EU Directive, the end customer equipment should be labelled as follows:



PAN1026 and its model versions in the specified reference design can be used in all countries of the European Economic Area (Member States of the EU, European Free Trade Association States[Iceland, Liechtenstein, Norway]), Monaco, San Marino, Andorra and Turkey.

CLASSIFICATION	PRODUCT SPECIFICATION	No. DS-1026-2400-102	REV. 1.9
SUBJECT	CLASS 2 BLUETOOTH LOW ENERGY SPP MODULE	PAGE	35 of 35
CUSTOMER'S CODE PAN1026	PANASONIC'S CODE ENW89837AxKF	DATE	16.06.2017

### 23.4 JAPANESE RADIO LAW COMPLIANCE:

This device is granted pursuant to the Japanese Radio Law (電波法).

This device should not be modified (otherwise the granted designation number will become invalid)

The following models are qualified for the Japanese market:

ENW89837AxKF

MIC ID: [R]202-LSE095

### 24 BLUETOOTH QUALIFICATION

Bluetooth End Products integrating PAN1026 need to be created by using following IDs:

<b>BT3.0:</b>	<b>Declaration ID</b>	<b>QDID</b>
Profile SubSystem (SDP/SPP)	B019234	36438
Controller Subsystem	B020093	40254
Host Subsystem	B019248	38386
 <b>BT4.0:</b>		
Profile Subsystem (Gatt)	B019935	40735
Controller Subsystem	B021165	48177
Host Subsystem	B020932	48566