

Infrared Array Sensor Grid-EYE

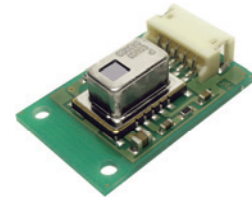

High Precision Infrared Array Sensor based on Advanced MEMS Technology

Features

- Temperature detection of two-dimensional area: 8 × 8 (64 pixels)
- Digital output (capability of temperature value output)
- PCB mounting with connector (5pin)
- RoHS compliant

Typical applications

- High function home appliances (microwaves)
- Energy saving at office (lighting control)
- Digital signage
- Automatic doors/elevators

Ordering information

AMG 8 8 5 4 M01

- Vertical pixel
8 : 8 pixels
- Horizontal pixel
8 : 8 pixels
- Applied voltage
5 : 5.0 V.DC
- Gain amplification factor
4 : High performance type Low gain

Type

Shipment package : 1,000 pcs.

Product name	Number of pixel	Operating voltage	Part number
Infrared array sensor Grid-EYE Narrow angle type	64 (Vertical 8 × Horizontal 8 Matrix)	5.0 V.DC	AMG8854M01

Ratings

Item	Performance
Applied voltage	5.0 V.DC±0.5 V.DC
Temperature range of measuring object	-20 °C to 100 °C -4 °F to +212 °F
Operating temperature range	-20 °C to 100 °C -4 °F to +212 °F
Storage temperature range	-20 °C to 100 °C -4 °F to +212 °F

Absolute maximum ratings

Item	Absolute maximum ratings	Terminal
Applied voltage	-0.3 V.DC to 6.5 V.DC	VDD
Input voltage	-0.3 V.DC to VDD +0.3 V.DC	SCL, SDA, AD_SELECT
Output sink current	-10 mA to 10 mA	INT, SDA
Static electricity (Human body model)	1 kV	All terminals
Static electricity (Machine model)	200 V	All terminals

Characteristics

Item	Performance
Temperature accuracy	Typical $\pm 3.0\text{ }^{\circ}\text{C}$ $\pm 5.4\text{ }^{\circ}\text{F}$
NETD *1	Max : $0.95\text{ }^{\circ}\text{C}$ $33.71\text{ }^{\circ}\text{F}$ 10 Hz
Viewing angle	Typ. $35.6\pm 3.0\text{ }^{\circ}$
Optical axis gap	Within 4.3 °
Current consumption	Max 6.0 mA (normal mode at $25\text{ }^{\circ}\text{C}$ $77\text{ }^{\circ}\text{F}$) Max 0.4 mA (sleep mode at $25\text{ }^{\circ}\text{C}$ $77\text{ }^{\circ}\text{F}$) Max 1.1 mA (stand-by mode at $25\text{ }^{\circ}\text{C}$ $77\text{ }^{\circ}\text{F}$)
Setup time	Typical 50 ms (Time to enable communication after setup) Typical 15 s (Time to stabilize output after setup)

Note: *1 It is calculated from 4 pixels of centers.

Performance

Item	Performance
Number of pixel	64 (Vertical 8 × Horizontal 8 Matrix)
External interface	I ² C (fast mode)
Frame rate	Typical 10 frames/sec or 1 frame/sec
Operating mode *1	Normal Sleep Stand-by (10 sec or 60 sec intermittence)
Output mode	Temperature output
Calculate mode	No moving average or Twice moving average
Temperature output resolution	$0.25\text{ }^{\circ}\text{C}$ $32.45\text{ }^{\circ}\text{F}$
I ² C slave address	1101 000
Thermistor output temperature range	$-20\text{ }^{\circ}\text{C}$ to $80\text{ }^{\circ}\text{C}$ $-4\text{ }^{\circ}\text{F}$ to $+176\text{ }^{\circ}\text{F}$
Thermistor output resolution	$0.0625\text{ }^{\circ}\text{C}$ $32.1125\text{ }^{\circ}\text{F}$

Note: *1 Normal Mode : normal operation mode; Sleep Mode: detection is off (output and data reading not possible); Standby Mode: 1 frame measuring intermittently every 10 or 60 sec.

Internal circuit

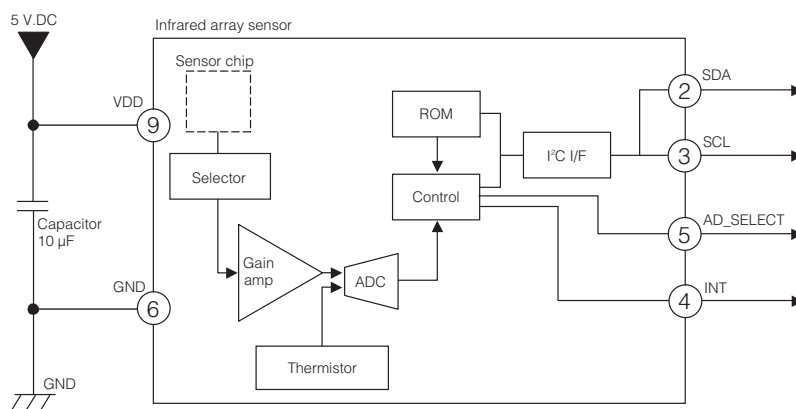

* INT terminal ④ normally has same voltage as VDD. When interrupting, same as GND (0V)

Print board circuit

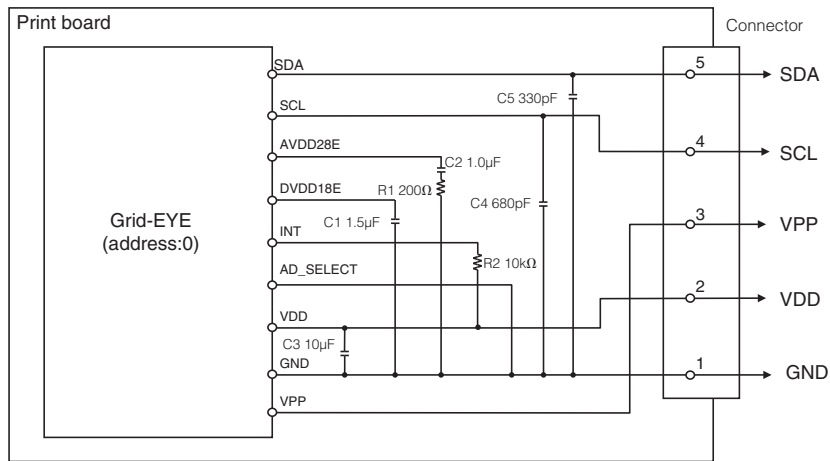

Pixel array and viewing field

(1) Pixel array
Pixel array from 1 to 64 is shown below.

(2) Viewing field
Sensor viewing field (typical) is shown below.

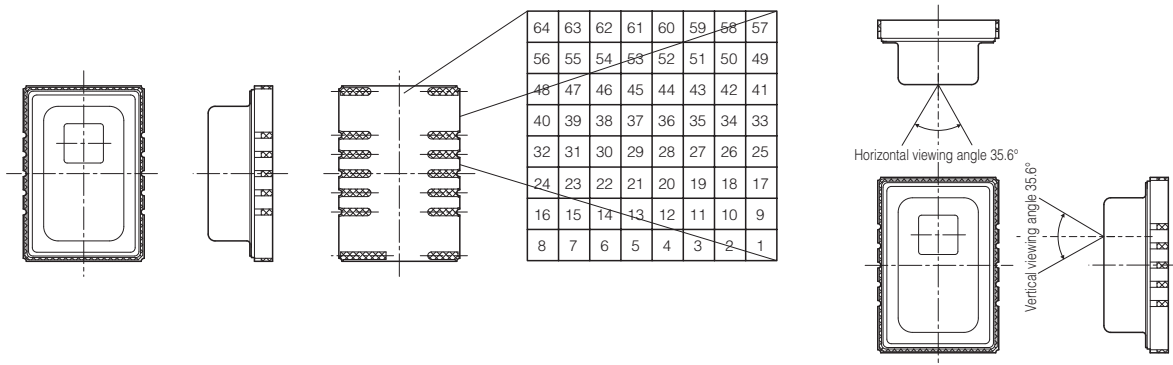

Optical properties

(1) Each pixel's viewing central angle
Sensor's optical center (the origin of graph below)
gap: within $\pm 4.3^\circ$ (Both horizontal and vertical directions)

(2) Each pixel's viewing angle (half angle)
Central 4 pixels (Pixel No. 28, 29, 36, 37) viewing angle (half angle): horizontal direction Typ. 5.0° vertical direction Typ. 4.7°

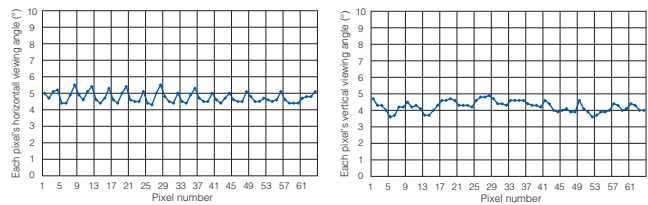
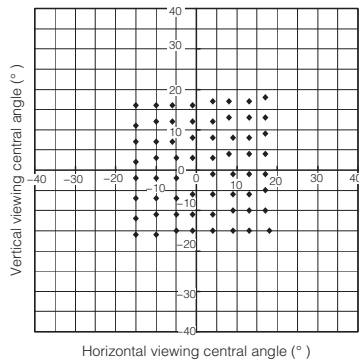

Dimensions

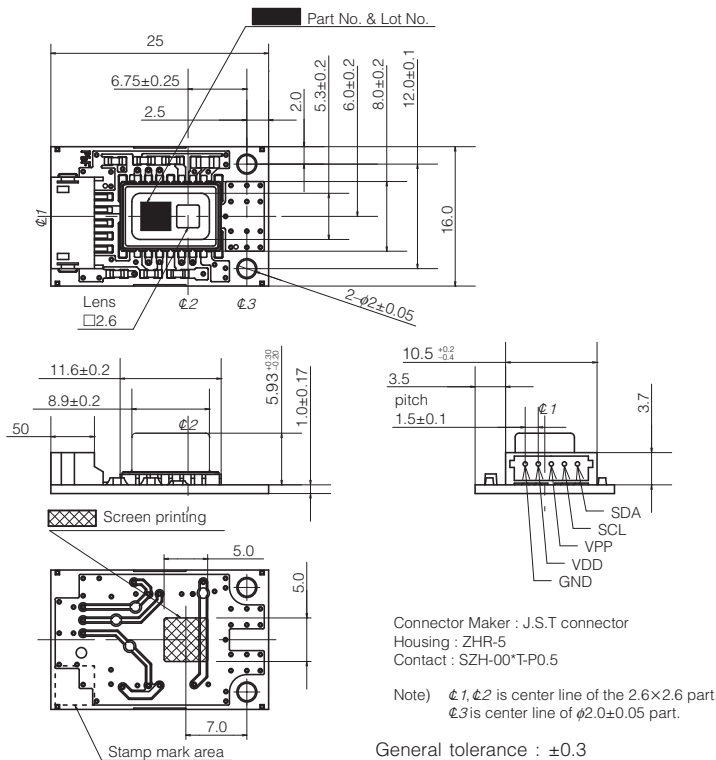

Notes

■ Precaution for fundamental structure of sensor

Infrared Array Sensor is a thermopile type infrared sensor which detects the amount of infrared rays. Below conditions generally degrade the temperature accuracy. Carefully check the performance and stability under actual use conditions, and perform temperature corrections when necessary.

- When heating elements exist near the Setting position of the sensor.
- When the sensor is exposed to cold or hot air.
- When the temperature of the sensor body rapidly changes.
- When substances (e.g., glasses, acrylics or steams), which hardly transmit a far infrared ray, exist between the sensor and the detected object.
- When substances (e.g., foreign substances or water), which hardly transmit a far infrared ray, adhere to the lens of the sensor.

■ Use environment

- 1) Temperature: See the specifications
- 2) Humidity: Between 15% and 85% R.H. (Avoid freezing and dew condensation)
- 3) Atmospheric pressure: Between 86 and 106 kPa
- 4) Vibrations and shocks may damage the sensor, and cause malfunction and performance deterioration. If loads and shocks are applied on the lens, the damaged sensor may cause malfunction and performance deterioration.
- 5) The product is not water/splash-proof. Perform water/dust-proofing and dew condensation/freezing countermeasures in accordance with use environment. When dew condensation occurs, responsiveness of heat source detection may delay for several seconds.

- 6) Avoid use and storage in the corrosive gas (organic solvent, sulfurous acid and hydrogen sulfide gases) to avoid malfunction and performance deterioration.
- 7) Use surge absorbers as applying the external surge voltage may damage the internal circuit.
- 8) Malfunction may occur near electric noises from static electricity, lightning, broadcast or amateur radio stations and mobile phones.
- 9) The sensor can continuously operate within the range of using ambient temperature (using ambient humidity). However, ensure that humidity is within the range described in the following page as humidity varies according to temperature. Avoid the continuous operation near the operational limit. The temperature range does not guarantee the durability.

■ Other precautions

These specifications are for individual components. Before use, carefully check the performance and quality under actual use conditions to enhance stability.

- 1) Once the individual sensor is dropped, do not use. Drop may cause functional disorders.
- 2) Writing to the unspecified register/with the unspecified bit may cause malfunction and performance deterioration. (please consult us)
- 3) Misconnection and use beyond the specified temperature range may damage the product.
- 4) Once below shocks are applied, do not use the product as applying highfrequency oscillation to the sensor body may damage the product.
 - Contact with metal objects
 - Contact with other sensors

- 5) Follow the instructions below as static electricity may damage the product.
 - For storage and transportation, avoid plastic containers which are easily electrified.
 - When storing and transporting the sensor, choose the environment where static electricity is hardly generated (e.g., humidity between 45 and 60 %) and protect the product by using electroconductive packaging materials.
 - Once unpacked, perform antistatic countermeasures.
 - (1) Operators handling sensors must wear antistatic cloths and human body grounding devices.
 - (2) Cover the surface of workbench by electro-conductive plates and ground measuring instruments and jigs.
 - (3) Ground the assembling equipment.
 - Use a stabilized power supply. A power superimposed noise may cause malfunction.

■ Range of using ambient temperature (using ambient humidity)

The sensor can continuously operate within the range of using ambient temperature (using ambient humidity). However, ensure that humidity is within the range below as humidity varies according to temperature. Avoid the continuous operation near the operational limit. Before use, check the stability under the usage environment as high humidity or high temperatures generally accelerates deterioration of the electronic component.

- The temperature range does not guarantee the durability

■ Storage and transportation

- 1) Excessive vibrations and shocks during transport may damage the product. Carefully handle the exterior box.
- 2) Extremely bad storage conditions may characteristics, and defect the appearance. Recommended conditions of the storage place are below.
 - Temperature: 0 to 45 °C 32 to 113 °F
 - Humidity: Below 70 % R.H.
 - Atmosphere: Low-dust and free from noxious chemicals such as sulfurous acid gas

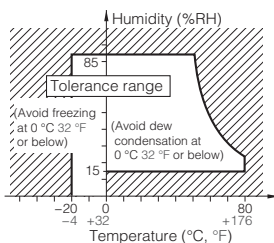

■ Special notes

We exert maximum efforts for quality control of the product, however :

- 1) To prevent occurrence of unexpected circumstances, please inform us of the specifications of your product, customers, use conditions and details of the attachment position.
- 2) Have sufficient margin values of driving/performance guarantee described in the specifications and apply safety measures with double circuits, if serious effects on human lives or property are predicted due to a quality failure of the product. Those countermeasures are also for the product liability.
- 3) A warranty period is one year after the delivery to your company. Quality assurance is limited to the items and the scopes described in the specifications.

If a defect is found after the delivery, we will promptly provide a replacement or change/repair the defect part at the place of delivery in good faith. Exceptions are below.

- Damages by a failure or a defect which arose after the delivery.
- After the delivery, when storing and transporting, if conditions other than conditions in the specifications are applied to the product.
- Damages by unforeseen phenomenon which cannot be predicted with the technologies available at the time of delivery.
- Damages by natural and anthropogenic disasters, such as earthquake, flood, fire and war, which are beyond our reasonable control.