

Applications

- Distributed power architectures
- Telecommunications equipment
- LAN/WAN applications
- Data processing applications

Features

- 75 Watts total output power
- Wide input range 18V – 60V
- Independent dual outputs
- Flexible load sharing
- Open-frame design with IMS board
- Low profile – 12.7mm height
- Start-up into high capacitive load
- Output overcurrent protection (self restart)
- Output overvoltage protection (self restart)
- Overtemperature protection (self restart)
- Setpoint accuracy $\pm 2.0\%$
- Output voltage trim adjust, independent for each output
- Input/output isolation: 1500V
- UL 1950 Recognition, CSA 22.2 No. 950-95 certification

Description

The HWD series provides onboard conversion of standard telecom and datacom input voltages into two isolated low-voltage outputs. These products offer a unique combination of wide input range, low profile, and high current capability. High efficiency and advanced thermal management enable these half-brick products to deliver full rated power at 55°C ambient temperature, with 200 LFM airflow, without the addition of heatsinks.

Model Selection						
Model	Input Voltage Range, VDC	Input Current, Max, ADC	Output Voltage, VDC	Output Rated Current, ADC	Output Ripple and Noise, mV p-p	Efficiency %
HWD075DGE-A	18-60	5.5	5.0/3.3	15/15	100	81% @ 24Vin 79% @ 48Vin

NUCLEAR AND MEDICAL APPLICATIONS - Power-One products are not authorized for use as critical components in life support systems, equipment used in hazardous environments, or nuclear control systems without the express written consent of the respective divisional president of Power-One, Inc.

TECHNICAL REVISIONS - The appearance of products, including safety agency certifications pictured on labels, may change depending on the date manufactured. Specifications are subject to change without notice.

Table 1. Absolute Maximum Ratings

Parameter	Symbol	Min	Max	Units
Input Voltage Continuous	V_i	-	60	VDC
Transient (100 msec)	V_i	-	100	VDC
Operating Baseplate Temperature Note 1	T_b	-40	+100	°C
Storage Temperature	T_{stg}	-55	+125	°C
Input to Output Isolation	-	-	1500	VDC
Output Short Circuit Duration	-	-	Continuous	-
Total Output Power	$P_{o,max}$	-	75	W
No Load Power Dissipation		-	6	W

Electrical Specifications

Unless otherwise indicated, specifications apply over all input voltages, resistive load, and $T_{bp}=+40^{\circ}\text{C}$.

Table 2. Input Specifications

Parameter	Symbol	Min	Typ	Max	Units
Voltage Range	V_i	18*	24/48	60	VDC
Maximum Input Current	I_i	-	-	5.5	A
Input Ripple Rejection (120 Hz)		-	60	-	dB
Inrush Transient		-	-	1	A^2s
Input Reflected Ripple (see figure 1)		-	-	250	mA p-p

- Module will operate within specification with an input voltage of 18 VDC, but must be turned on with an input voltage > 19.5 VDC. See Undervoltage Lockout Specification.

Fusing Considerations

CAUTION

This DC-DC converter is not internally fused. An external input fuse must always be used.

Table 3. Output Specifications

Parameter	Symbol	Min	Typ	Max	Units	
Output Power	Po1	-	-	75	W	
	Po2	-	-	50	W	
	Po1+Po2	-	-	75	W	
Output Voltage Set Point (Vi=24VDC or Vi=48VDC, Io1,Io2=7.5A)	Vo1	4.9	5.0	5.1	VDC	
	Vo2	3.23	3.3	3.37	VDC	
Output Line Regulation: (Vi=Vi,min to Vi,max) (Io1, Io2=7.5A)	Vo1,Vo2	-	0.05	0.2	%	
Output Load Regulation: (Io,min to Io,max)	Vo1,Vo2	-	0.5	1	%	
Output Temperature Regulation: (Tbase =-40°C to +100°C)	All Outputs	-	0.02	0.05	%/°C	
Output Current (Maximum output power limited to 75W)	Io1	0.5	7.5	15	A	
	Io2	0.5	7.5	15	A	
Output Ripple (See Figure 2) (DC to 20MHz) (Io1,Io2 = 7.5A)	Vo1	-	75	100	mVp-p	
	Vo2	-	75	100	mVp-p	
Output Current Limit inception (Other outputs at no load)	Io1	-	17	19	A	
	Io2	-	21	23	A	
Transient Response (50% to 100% Load Step, $\Delta I_o/\Delta t=0.1A/uSec$)						
	Peak Deviation	Vo1	-	100	200	mV
		Vo2	-	200	300	mV
Settling Time (Vo, 1% of Vo1)		-	150	250	μsec	
	Overvoltage Limit	Vo1,clamp	5.9	-	6.5	VDC
	Vo2,clamp	3.6	-	4.7	VDC	

Table 4. Feature Specifications

Parameter	Symbol	Min	Typ	Max	Units	
Remote On/Off, Primary side						
Vlow		-	-	1	V	
Vhigh		-	-	7	V	
Sink Current-Logic Low		-	-	2	mA	
Turn-on time (Within 1% V _{o,nom})		-	3.5	5	msec	
Switching Frequency		-	350	-	kHz	
Output Voltage Adjust	Adjust Up	Vo1	5.39	5.5	5.61	VDC
		Vo2	3.55	3.63	3.71	VDC
	Adjust Down	Vo1	4.41	4.5	4.59	VDC
		Vo2	2.91	2.97	3.03	VDC
Thermal Shutdown		+105		+115	°C	
Undervoltage Lockout	Turn-on	-	19.2	19.5	V	
	Turn-off	16.5	16.8	-	V	

Table 5. Environmental

Parameter	Min	Typ	Max	Units
Operating Baseplate Temperature	-40	-	+100	°C
Operating Humidity (non-condensing)	-	-	95	%
Storage Humidity (non-condensing)	-	-	95	%

Table 6. Isolation Specifications

Parameter	Min	Typ	Max	Units
Input to Each Output	1500	-	-	VDC
Input to Baseplate	1500	-	-	VDC
Output to Output	-	-	-	VDC
Resistance, Input - Output	10	-	-	MΩ
Capacitance, Input - Output	-	2200	-	pF

Table 7. EMI and Regulatory Agency Compliance

Conducted Emissions (With input filter configuration in Figure 3.)	CISPR 22 class A
Safety	UL60950 Recognized, CAN/CSA C22.2 No. 60950-00 Recognized

Table 8. General Specifications

Parameter	Min	Typ	Max	Units
Efficiency η ($V_i=24VDC$, $I_{o1}, I_{o2} = 7.5A$)	79	81	-	%
($V_i=48VDC$, $I_{o1}, I_{o2} = 7.5A$)	77	79	-	
Calculated MTBF ($P_o=60W$, $T_{bp}=40^\circ C$)	-	900	-	kHrs

Table 9. Physical

Parameter				Units
Dimensions	2.30 (58.4)	2.40 (60.9)	0.50 (12.70)	in (mm)
Weight			2.4(68)	oz(g)
Markings & labeling	Includes Part Number, Power-One Logo, Date Code and Country of Manufacture			

Mechanical Diagram

Pin	Function
1	-Vin
2	Case
3	On/Off
4	+Vin
5	+Vo2
6	+Vo2 Rtn
7	Trim 2
8	+Vo1
9	+Vo1 Rtn
10	Trim 1

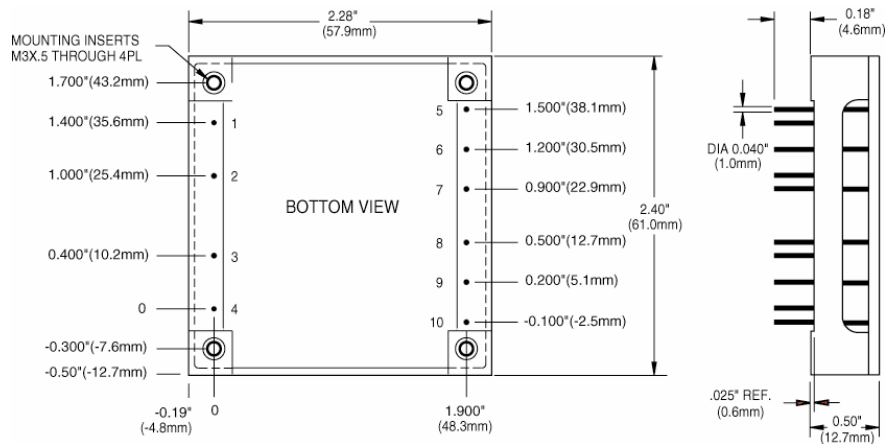

Table 10. Ordering Information

Options	Suffixes to add to part number
Remote On/Off	Positive- Standard, no suffix required
	Negative- Add "N" suffix
Trim	Negative- Standard, no suffix required
Pin Length	0.18"- Standard, no suffix required
	0.11"- Add "8" suffix
	0.15"- Add "9" suffix

Notes

1. Consult factory for the complete list of available options.

Test Setup

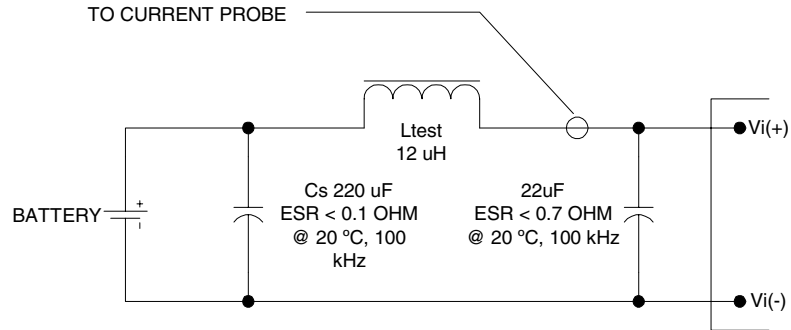

Figure 1. Input Reflected Ripple Current Test Set-up

Note: Measure input reflected-ripple current with a simulated inductance (L_{test}) of 12 μ H. Capacitor C_s offsets possible battery impedance. Measure current as shown above.

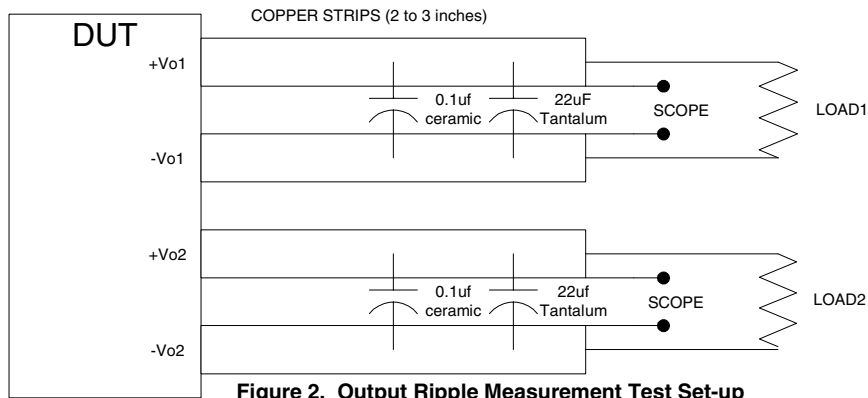

Figure 2. Output Ripple Measurement Test Set-up

Note: Use a 0.1 μ F ceramic and 22 μ F tantalum capacitor. Scope measurement should be made using a BNC socket. Position loads between 51 mm and 76 mm (2 in. and 3 in.) from module.

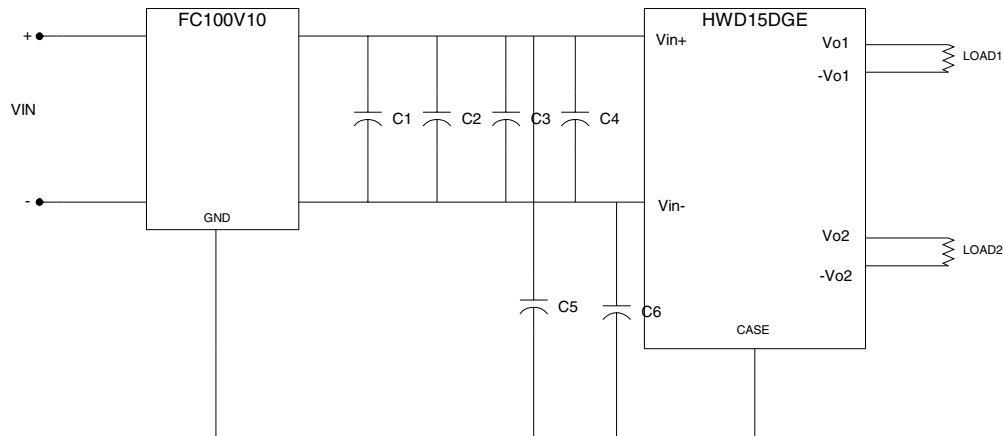

Figure 3. Input Filter Configuration Required to Meet CISPR 22 Class A for Conducted Emissions

Table 11. Part List for Input Filter

Ref. Des	Description	Manufacture
C1, 2	0.47uF @ 100V MLC Capacitor (1812)	AVX or Equivalent (Equiv.)
C3	100uF @ 100V Alum. Electrolytic Capacitor	Nichicon NRSZ Series or Equiv.
C4	22uF @ 100V Alum. Electrolytic Capacitor	United Chemicon KMG Series or Equiv.
C5, 6	0.01uF MLC Capacitor	AVX or Equiv.
F1	FC100V10 Input Filter Module	Power-One

FEATURE DESCRIPTIONS

Output Overvoltage Clamp

The output overvoltage clamp consists of a separate control loop, independent of the primary control loop. This control loop has a higher voltage setpoint than the primary loop. In a fault condition the converter goes into “Hiccup Mode”, and the output overvoltage clamp ensures that the output voltage does not exceed $V_{o,clamp,max}$. This secondary control loop provides a redundant voltage control that reduces the risk of output overvoltage.

Output Current Protection

To provide protection in an output overload or short circuit condition, the converter is equipped with current limiting circuitry and can endure the fault condition for an unlimited duration. At the point of current-limit inception, the converter goes into “Hiccup Mode”, causing the output current to be limited both in peak and duration. The converter operates normally once the output current is brought back into its specified range.

Enable

Two enable options are available. Positive Logic Enable and Negative Logic Enable. Positive Logic Enable turns the converter ON during a logic-high voltage on the enable pin, and OFF during a logic-low. Negative Logic Enable turns the converter OFF during a logic-high and ON during a logic-low.

Output Voltage Adjustment

Output voltage adjustment is accomplished by connecting an external resistor between the Trim Pin and either the +Vo1 or -Vo1 Pins.

With an external resistor between the Trim Pin and +Vo1 Pin (Radj-down) the output voltage set point (Vo,adj) decreases. The following equation determines the required external resistor value to obtain an adjusted output voltage:

$$R_{adj, dn} = \left[\frac{(V_{o,adj} - D)A}{V_{o,nom} - V_{o,adj}} - B \right] \text{ ohm}$$

Where Radj-down is the resistance value and A, B, and D are defined in Table 7.

With an external resistor between the Trim Pin and -Vo1 Pin (Radj-up) the output voltage set point (Vo,adj) increases. The following equation determines the required external resistor value to obtain an adjusted output voltage:

$$R_{adj, up} = \left[\frac{A \cdot D}{(V_{o,adj} - D) - C} - B \right] \text{ ohm}$$

Where Radj-up is the resistance value and A, B, C, and D are defined in Table 12.

Table 12. Output Adjustment Variables

Output	A	B	C	D
Vo1	4990	2000	2.5	2.5
Vo2	4990	2000	0.8	2.5

THERMAL CONSIDERATIONS

The power converter operates in a variety of thermal environments: however, sufficient cooling should be provided to help ensure reliable operation of the converter. Heat-dissipating components are thermally coupled to the case. Heat is removed by conduction, convection, and radiation to the surrounding environment. Proper cooling can be verified by measuring the case temperature.

Heat Transfer Characteristics

Increasing airflow over the converter enhances the heat transfer via convection. Figure 4 shows the maximum power that can be dissipated by the converter without exceeding the maximum case temperature versus local ambient temperature (TA) for natural convection through 400 ft/min.

Systems in which these converters are used generate airflow rates of 50 ft/min due to other heat dissipating components in the system. Therefore, the natural convection condition represents airflow rates of approximately 50 ft/min. Use of Figure 4 is shown in the following example.

Example

What is the minimum airflow required for the device operating at 24 V, an output power of 60 W, and maximum ambient temperature of 60 °C.

Solution:

Given: Vi = 24 V, Po = 60 W, TA = 60 °C.

Determine PD (Figure 4): PD = 13 W.

Determine airflow (Figure 4): v = 200 ft/min

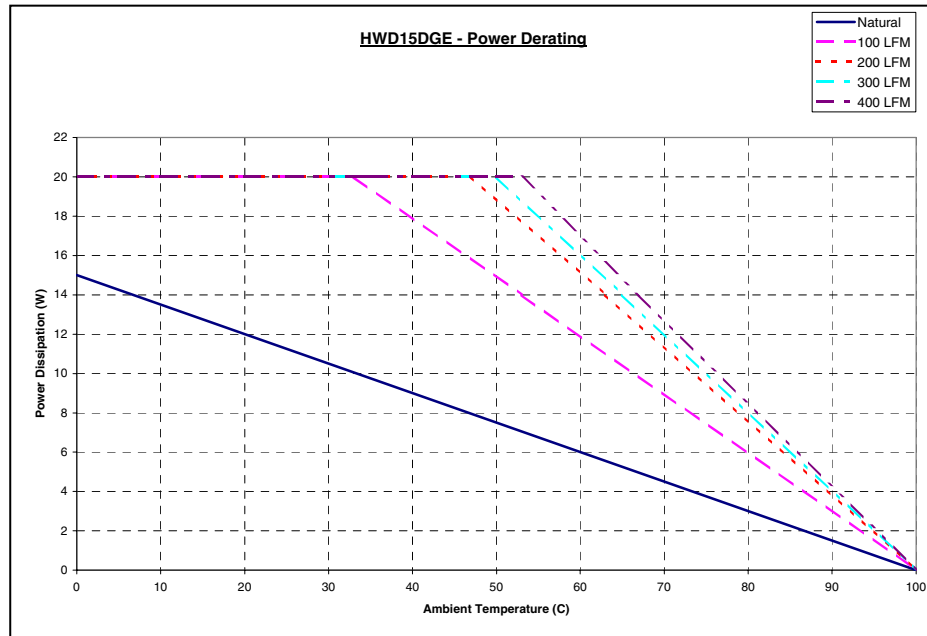

Figure 4. Power Derating Curve

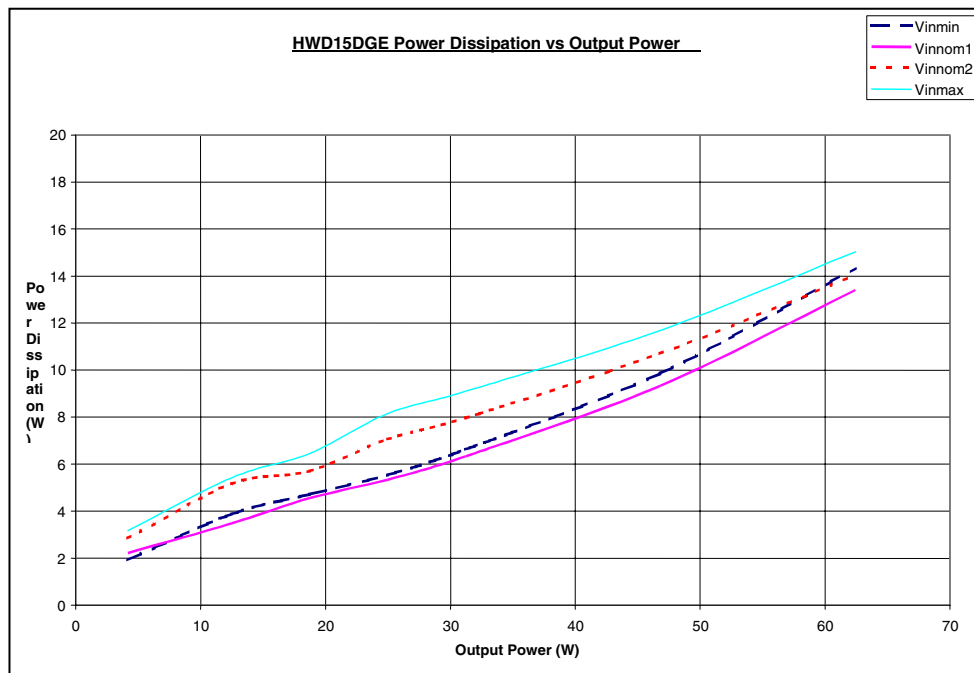

Figure 5. Power Dissipation Vs. Output Power

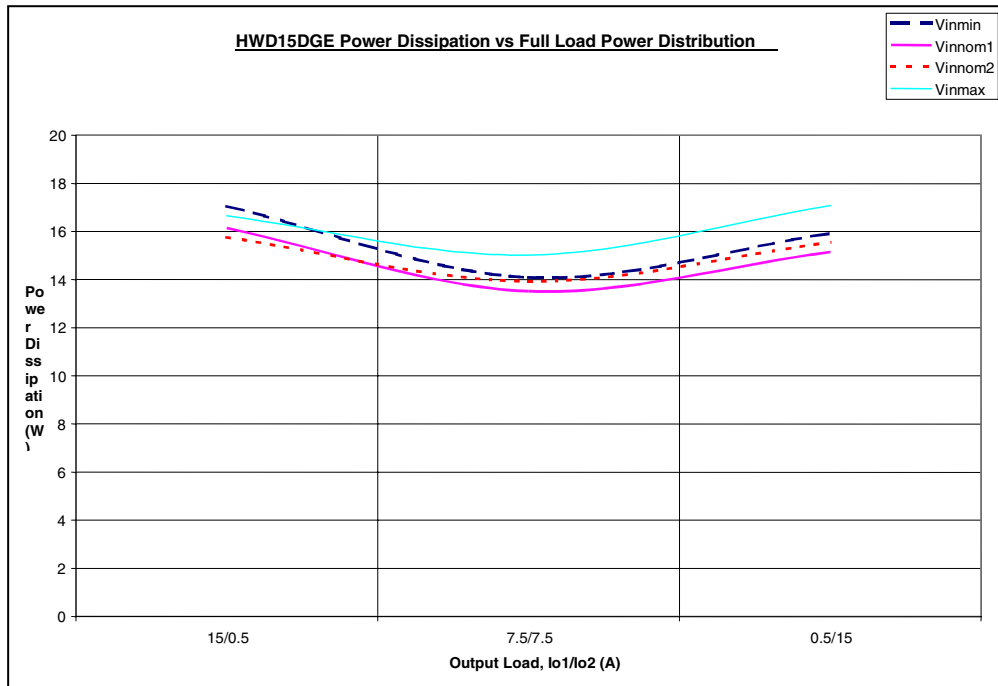

Figure 6. Power Dissipation Vs. Full-Load Distribution

Characteristic Curves

T_b = 40 °C, nominal input voltage, and rated load unless otherwise specified.

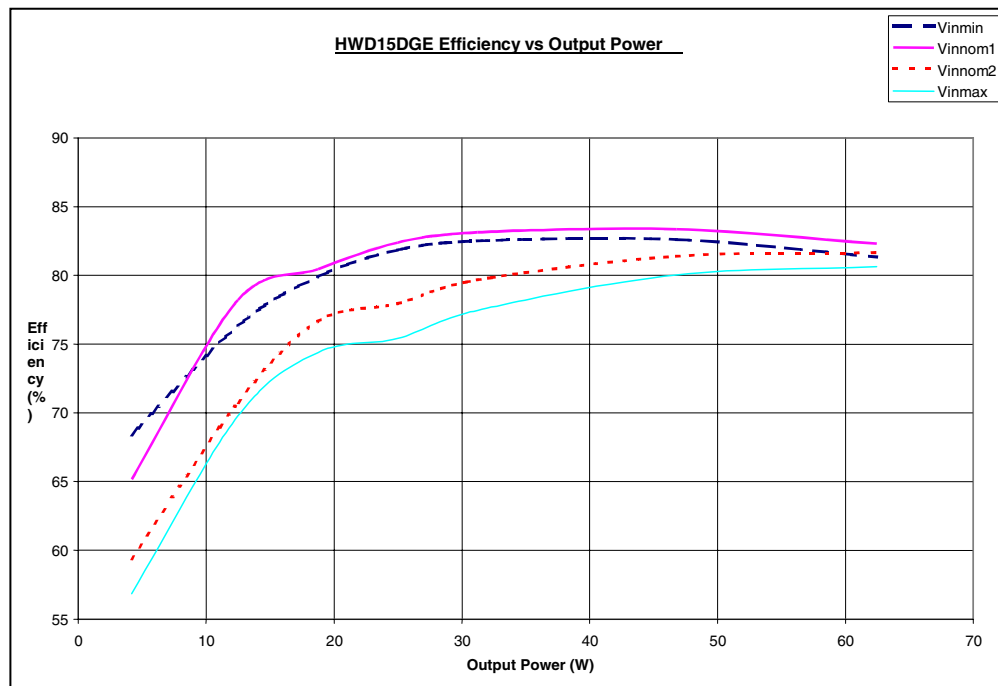

Figure 7. Efficiency Vs. Output Power

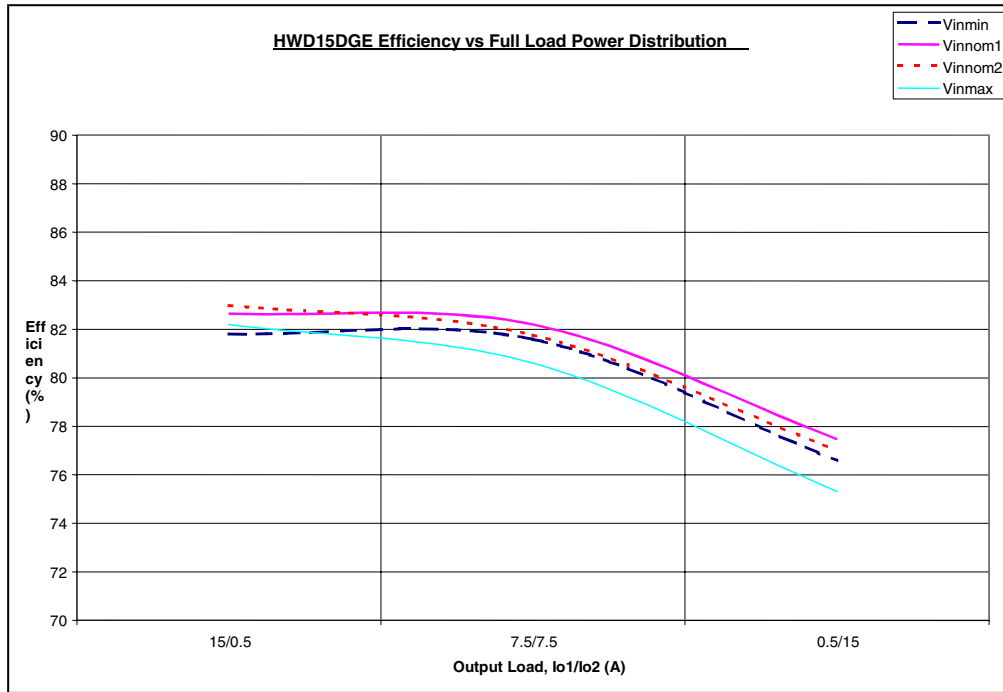

Figure 8. Efficiency Vs. Full-Load Power Distribution

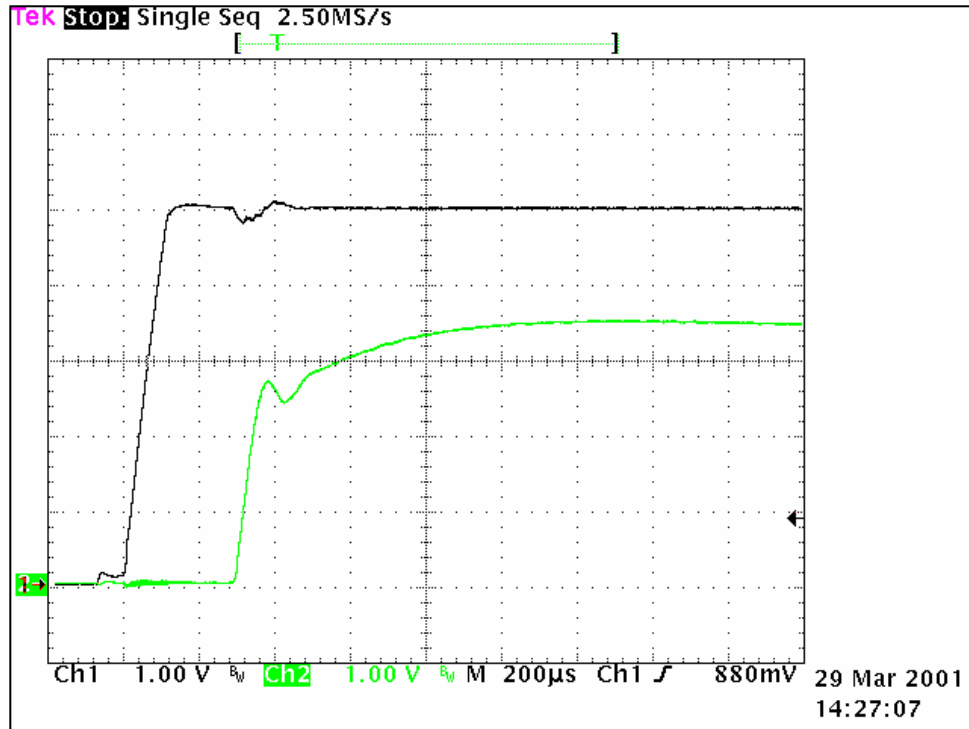

Figure 9. Typical Turn-ON Characteristics

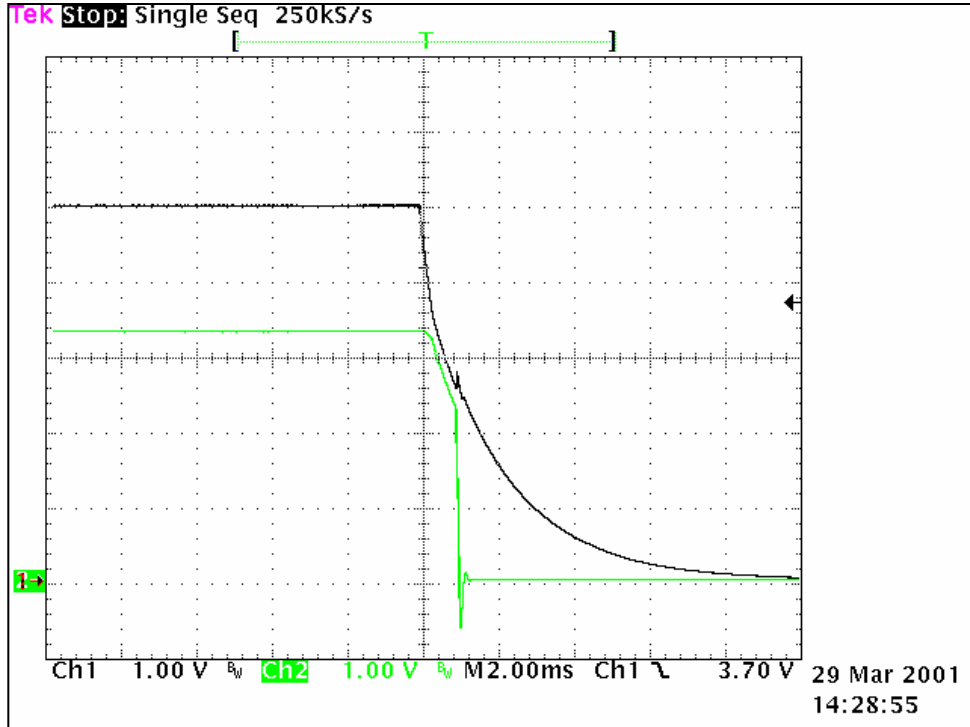

Figure 10. Typical Turn-OFF Characteristics