

Features

- RoHS lead-free-solder and lead-solder-exempted products are available.
- Class I equipment
- Power factor >0.93, harmonics IEC/EN 61000-3-2
- Immunity according to IEC/EN 61000-4-2, -3, -4, -5, -6
- High efficiency
- Input over- and undervoltage lockout
- Adjustable output voltage with remote on/off
- 1 or 2 outputs: SELV, no load, overload, and short-circuit proof
- Rectangular current limiting characteristic
- Immunity accord. to IEC 61000-4-2, -3, -4, -5, -6
- PCBs protected by lacquer
- Very high reliability

Safety-approved to IEC/EN 60950-1 and UL/CSA 60950-1 2nd Ed.



Description

The LK 4000/5000 Series of AC-DC converters represents a flexible range of power supplies for use in advanced electronic systems; the LKP models are an extension with increased output power, but optimized to 230 VAC. Features include full power factor correction, good hold-up time, high efficiency and reliability, low output noise, and excellent dynamic response to load/line changes.

The converters are protected against surges and transients occurring at the source lines. Input over- and undervoltage lockout circuitry disables the outputs, when the input voltage is outside of the specified range. Input inrush current limitation is included for preventing circuit breakers and fuses from tripping at switch-on.

All outputs are overload, open- and short-circuit proof, and protected by a built-in suppressor diode. The outputs can be inhibited by a logic signal applied to connector pin 18. If the inhibit function is not used, pin 18 must be connected with pin 14 to enable the outputs.

LED indicators display the status of the converter and allow visual monitoring of the system at any time.

Full input to output, input to case, output to case and output to output isolation is provided. The converters are designed and built according to the international safety standards IEC/EN 60950-1 2nd Ed. They have been approved by the safety agencies TÜV and CSA (for USA and Canada).

The case design allows operation at nominal load up to 71 °C in a free air ambient temperature. If forced cooling is provided, the ambient temperature may exceed 71 °C, but the case temperature must remain below 95 °C under all conditions. However, higher output power up to 280 W is possible depending on environmental conditions and converter model.

An internal temperature sensor generates an inhibit signal, which disables the outputs, when the case temperature T_C exceeds the limit. The outputs automatically recover, when

Table of Contents

	Page		Page
Description	1	Electromagnetic Compatibility (EMC)	16
Model Selection	2	Environmental Conditions	17
Functional Description	4	Mechanical Data	18
Electrical Input Data	5	Safety and Installation Instructions	20
Electrical Output Data	8	Description of Options	22
Auxiliary Functions	13	Accessories	28

the temperature drops below the limit.

Various options are available to adapt the converters to individual applications. An external temperature sensor is available to allow for temperature adapted battery charging.

The converters may either be plugged into 19" rack

systems according to IEC 60297-3, or be mounted on a chassis or plate.

Important:

These products are intended to replace the LK1000 and LK2000 models, in order to comply with IEC/EN 61000-3-2. For applications with DC input or main frequencies other than 50/60 Hz, the LK1000 and LK2000 models are still available.

Model Selection

Non-standard input/output configurations or special customer adaptations are available on request.

Table 1: Standard models

Output 1		Output 2		Operating input range $V_{i\ min} - V_{i\ max}$ [VAC]	Type designation	Efficiency ¹ $\eta_{\ min}$ [%]	Options	
$V_{o\ nom}$ [VDC]	$I_{o\ nom}$ [A]	$V_{o\ nom}$ [VDC]	$I_{o\ nom}$ [A]					
5.1	20	–	–	85 – 264	LK4002-7R	79	E, P, D, V ² , P, T, K ⁵ , B, B1, B2 ⁴ , G	
5.1	25	–	–		LK4003-6R			79
12	12	–	–	85 – 264	LK4301-7R	84	-9E, P, D, T, B, B1, B2 ⁴ , G	
15	10	–	–		LK4501-7R			85
24	6	–	–		LK4601-7R			86
12	6	12 ³	6	85 – 264	LK5320-7R	82	-9E, P, D, T, B, B1, B2 ⁴ , G	
15	5	15 ³	5		LK5540-7R			83
24	3	24 ³	3		LK5660-7R			83
12	10	12 ³	10	187 – 255	LKP5320-6R	85	E, P, D, T, B, B1, B2 ⁴ , G	
24	5.2	24 ³	5.2		LKP5660-7R			86
24	5.8	24 ³	5.8		LKP5661-5R			86

¹ Min. efficiency at $V_{i\ nom}$, $I_{o\ nom}$ and $T_A = 25\ ^\circ\text{C}$. Typical values are approximately 2% better.

² Option V for models with 5.1 V outputs; excludes option D

³ Second output semi-regulated

⁴ For customer-specific models with 220 mm case length

⁵ For new designs, use only option K.

Table 2: Battery charger models

Nom. output values		Output range ⁵ $V_{o\ min} - V_{o\ max}$ [VDC]	Operating input range $V_{i\ min} - V_{i\ max}$ [VAC]	Type designation	Efficiency ¹ $\eta_{\ min}$ [%]	Options	
$V_{o\ nom}$ [VDC]	$I_{o\ nom}$ [A]						
12.84	10	12.62 – 14.12	85 – 264	LK4740-7R	84	-9E, D, T, B, B1, B2 ⁴ , G	
25.68 ²	5.4	25.25 – 28.25		LK5740-7R			83
51.36 ³	2.7	25.5 – 56.5		LK5740-7R			83
25.68 ²	9	25.25 – 28.25	187 – 255	LKP5740-7R	86	-9E, D, T, B, B1, B2 ⁴ , G	
25.68 ²	10	25.25 – 28.25		LKP5741-5R			86
51.36 ³	4.5	50.5 – 56.5	187 – 255	LKP5740-7R	86	-9E, D, T, B, B1, B2 ⁴ , G	
51.36 ³	5	50.5 – 56.5		LKP5741-5R			85

¹ Min. efficiency at $V_{i\ nom}$, $I_{o\ nom}$ and $T_A = 25\ ^\circ\text{C}$. Typical values are approximately 2% better.

² Both outputs connected in parallel

³ Both outputs connected in series

⁴ For customer-specific models with 220 mm case length

⁵ Controlled by the battery temperature sensor, see *Accessories*

Part Number Description

Operating input voltage V_i :		LK	5	5	40	-9	E	P	D3	T	K	B1
85 – 264 VAC	LK	_____										
187 – 255 VAC	LKP	_____										
Number of outputs (4 = single, 5 = double)	4, 5	_____										
Single-output models:												
Nominal voltage output 1 (main output), $V_{O1\ nom}$												
5.1 V	0, 1, 2	_____										
12 V	3	_____										
15 V	4, 5	_____										
24 V	6	_____										
Other voltages ¹	7, 8	_____										
Other specifications (single-output models) ¹	21 – 99	_____										
Double-output models:												
Nominal voltage output 1 and 2												
12 V, 12 V	20	_____										
15 V, 15 V	40	_____										
24 V, 24 V	60	_____										
Other specifications or additional features ¹	70 – 99	_____										
Operational ambient temperature range T_A :												
-25 to 71 °C	-7	_____										
-40 to 71 °C	-9	_____										
-25 ² to 60 °C	-6	_____										
-25 ² to 50 °C	-5	_____										
Other ¹	0	_____										
Auxiliary functions and options:												
Inrush current limitation	E ²	_____										
Output voltage control input	R ³	_____										
Potentiometer (output voltage adjustment)	P ³	_____										
Undervoltage monitor (D0 – DD, to be specified)	D ⁴	_____										
ACFAIL signal (V2, V3, to be specified)	V ⁴	_____										
Current share	T	_____										
H15S4 connector (rather than H15S2)	K ⁵	_____										
Cooling plate standard case	B or B1	_____										
Cooling plate for long case 220 mm ¹	B2	_____										
RoHS-compliant for all 6 substances	G ⁶	_____										

¹ Customer-specific models
² Option E is mandatory for all -9 models. Models with -5E or -6E are functional down to -40 °C.
³ Feature R excludes option P and vice versa. Option P is not available for battery charger models.
⁴ Option D excludes option V and vice versa; option V is available for models with 5.1 V output only (LK4003, etc.).
⁵ Option K is available for models with 5.1 V output only (LK4002, LK4003, etc.) to ensure compatibility with LK1001 models.
⁶ G is always placed at the end of the part number.

Example: LK5540-9EPD3TB1: Power factor corrected AC-DC converter, operating input voltage range 85 – 264 VAC, 2 electrically isolated outputs, each providing 15 V, 5 A, equipped with inrush current limiter, a potentiometer to adjust the output voltages, undervoltage monitor D3, current share feature, and a cooling plate B1.

Product Marking

Basic type designation, applicable approval marks, CE mark, warnings, pin designation, Power-One patents and company logo, identification of LEDs, test sockets, and potentiometer.

Specific type designation, input voltage range, nominal output voltages and currents, degree of protection, batch no., serial no., and data code including production site, modification status, and date of production.

Functional Description

The input voltage is fed via an input fuse, an input filter, a rectifier, and an inrush current limiter to a boost converter. This step-up converter provides a sinusoidal input current (IEC/EN 61000-3-2, class D equipment) and charges the bulk capacitor C_b to approx. 370 VDC. This capacitor sources a single-transistor forward converter and provides the power during the hold-up time.

The main transformer exhibits a separate secondary winding for each output. Each generated voltage is rectified and smoothed by the power choke and the output

filter. The control logic senses the main output voltage V_o or V_{o1} and generates, with respect to the maximum admissible output currents, the control signal for the switching transistor of the forward converter.

The second output of double output models is tracking to the main output, but has its own current limiting circuit. If the main output voltage drops due to current limitation, the second output voltage will fall as well and vice versa.

A separate auxiliary converter generates the supply voltages for all primary and secondary control circuits and options.

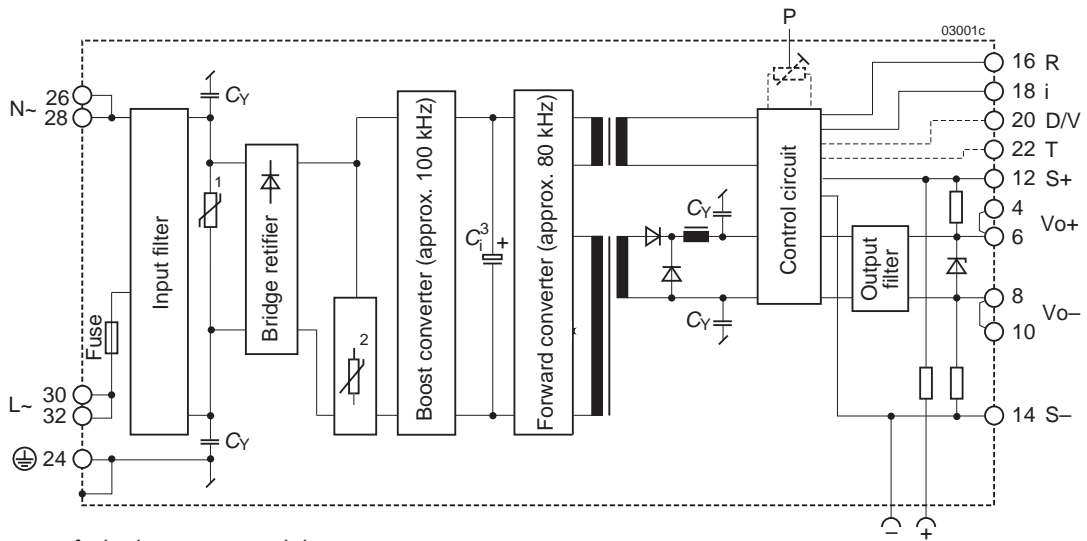

Fig. 1
Block diagram of single-output models

- 1 Transient suppressor (VDR)
- 2 Inrush current limiter (NTC, only models with $T_{A \text{ min}} = -25 \text{ }^\circ\text{C}$) or option E
- 3 Bulk capacitor C_b ; bulk voltage approx. 370 V

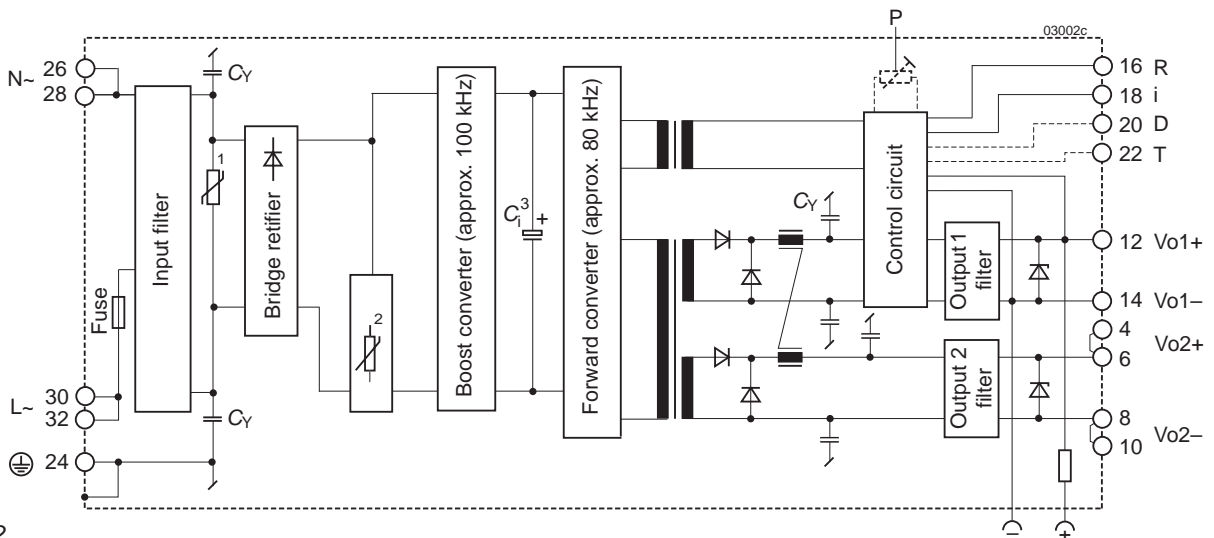

Fig. 2
Block diagram of double-output models

- 1 Transient suppressor (VDR)
- 2 Inrush current limiter (NTC, only models with $T_{A \text{ min}} = -25 \text{ }^\circ\text{C}$) or option E
- 3 Bulk capacitor C_b ; bulk voltage approx. 370 V

Electrical Input Data

General Conditions:

- $T_A = 25\text{ °C}$, unless T_C is specified.
- Pin 18 connected to pin 14, R input not connected, V_o adjusted to $V_{o\text{ nom}}$ (option P)
- Sense line pins S+ and S– connected to Vo+ and Vo–, respectively (single-output models)

Table 3: Electrical input data

Input		Conditions	LK			LKP			Unit
Characteristics			min	typ	max	min	typ	max	
V_i	Rated input voltage range	$I_o = 0 - I_{o\text{ nom}}$	100		240	200		240	VAC ¹
$V_{i\text{ op}}$	Operating input voltage range	$T_C\text{ min to }T_C\text{ max}$	85		264	187		255	
$V_{i\text{ nom}}$	Nominal input voltage	50 – 60 Hz		230			230		
I_i	Input current	$V_{i\text{ nom}}, I_{o\text{ nom}}^2$		0.8			1.25	A	
P_{i0}	No-load input power	$V_{i\text{ min}} - V_{i\text{ max}}, I_o = 0$		9	10		9	10	W
$P_{i\text{ inh}}$	Idle input power	converter inhibited		3.5	5		3.5	5	
R_i	Input resistance		480			480		mΩ	
R_{NTC}	NTC resistance (see fig. 3) ³	conv. not operating	3200	4000		3200	4000		
C_b	Input capacitance		100	150	180	110	136	165	μF
$V_{i\text{ RFI}}$	Conducted input RFI	EN 55011/55022		B			B		
	Radiated input RFI	$V_{i\text{ nom}}, I_{o\text{ nom}}$		A			B		
$V_{i\text{ abs}}$	Input voltage limits without damage				283			283	VAC
			-400	400		-400	400		VDC ⁴

¹ Rated input frequency: 50 – 60 Hz, operating frequency: 47 – 63 Hz. For operation at other frequencies, contact Power-One.

² With double-output models, both outputs loaded with $I_{o\text{ nom}}$

³ Valid for models without option E. This is the value of the NTC resistance at 25 °C and applies to cold converters for the initial switch-on cycle. Subsequent switch-on/off cycles increase the inrush current peak value.

⁴ Operation with DC input voltage is not specified and not recommended.

Input Fuse and Protection

A VDR together with the input fuse and a symmetrical input filter form an effective protection against high input transient voltages.

A fuse mounted inside the converter in series to the phase line protects against severe defects. A second fuse in the neutral line may be necessary in certain applications; see *Installation Instructions*.

Table 4: Fuse specification

Model	Fuse type	Fuse rating
LK4/5000	slow-blow	SP T, 4 A, 250 V, 5 × 20 mm
LKP	slow-blow	SP T, 4 A, 250 V, 5 × 20 mm

Input Under-/Overvoltage Lockout

If the input voltage remains below approx. 65 VAC (LKP: 150 VAC) or exceeds $V_{i\text{ abs}}$, an internally generated inhibit signal disables the output(s). Do not check the overvoltage lockout function!

If V_i is below $V_{i\text{ min}}$, but above the undervoltage lockout level, the output voltage may be below the value specified in the tables *Electrical Output Data*.

Inrush Current Limitation

The models without option E incorporate an NTC resistor in the input circuitry, which at initial turn-on reduces the peak inrush current value by a factor of 5 to 10 to protect connectors and switching devices against damage. Subsequent switch-on cycles within short periods will cause an increase of the peak inrush current value due to the warming-up of the NTC resistor.

The inrush current peak value (initial switch-on cycle) can be determined by following calculation:

$$I_{i\text{ nr p}} = \frac{V_i \cdot \sqrt{2}}{(R_{s\text{ ext}} + R_i + R_{\text{NTC}})}$$

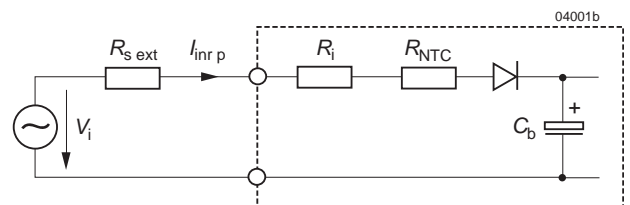

Fig. 3
Equivalent circuit diagram for input impedance.

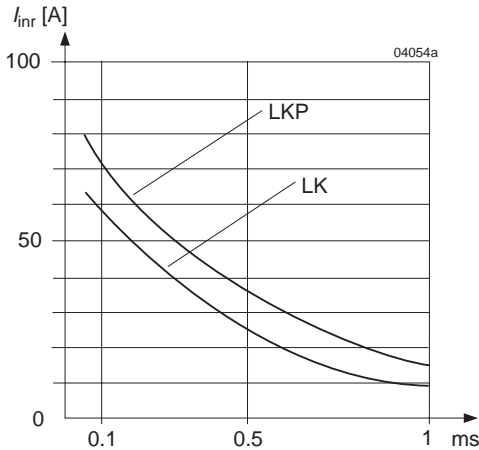

Fig. 4
Theoretical worst case input inrush current versus time at $V_i = 255\text{ V}$, $R_{ext} = 0$ for models without option E

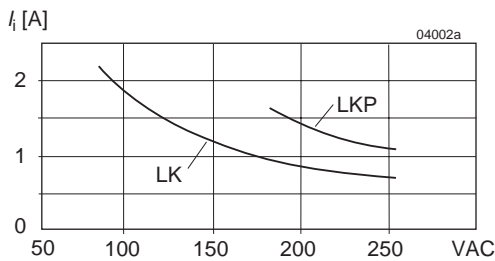

Fig. 5
Input current versus input voltage at $I_o\text{ nom}$

Power Factor and Harmonics

Power factor correction is achieved by controlling the input current waveform synchronously with the input voltage waveform. The power factor control is active under all operating conditions.

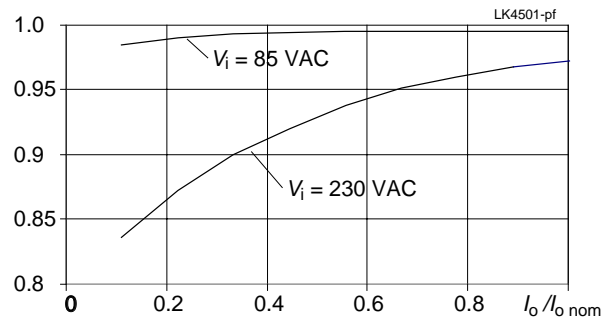

Fig. 6
Power factor versus output current (LK4501-7R)

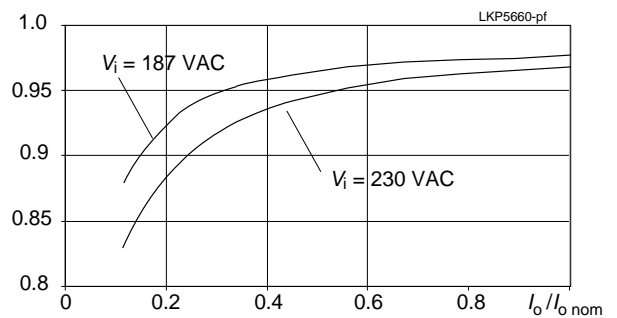

Fig. 7
Power factor versus output current (LKP5660-7R)

The harmonic distortion is well below the limits specified in IEC/EN 61000-3-2, class D; see fig. below:

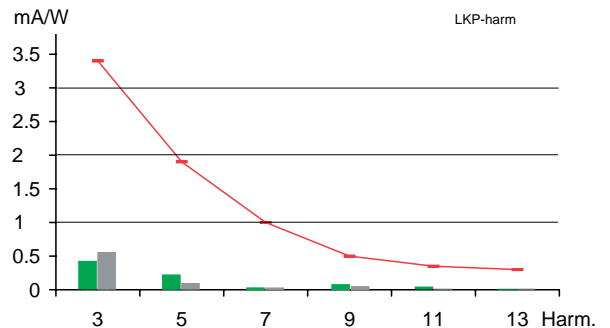

Fig. 8
Harmonic input currents at $V_i = 230\text{ V}$, $I_o = I_o\text{ nom}$ for LK4501-7R (left bars) and LKP5660-7R.

Switching Frequency

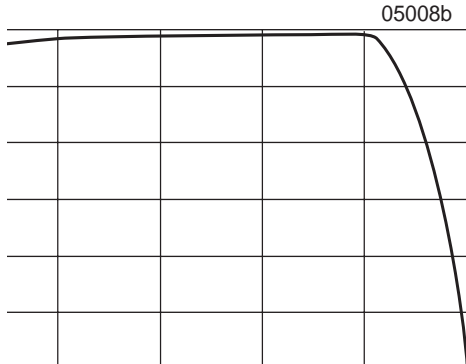

Fig. 9
Typical switching frequency of the DC/DC converter versus load (The boost converter at the input stage operates with a constant switching frequency of 100 kHz.)

Efficiency

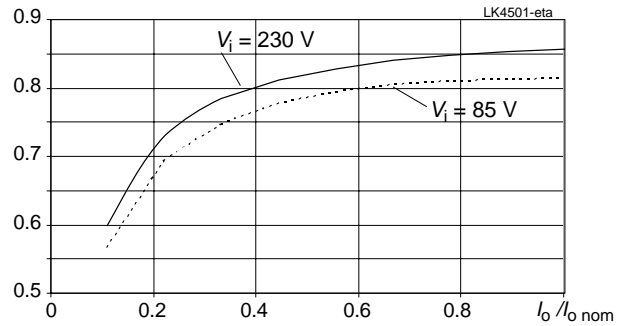

Fig. 11a
Efficiency versus output current (LK4501-7R)

Hold-up Time

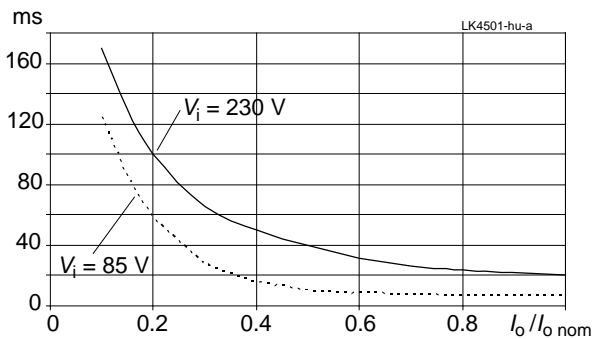

Fig. 10a
Hold-up time versus output power (LK4501-7R), valid for converters with version V102 or higher.

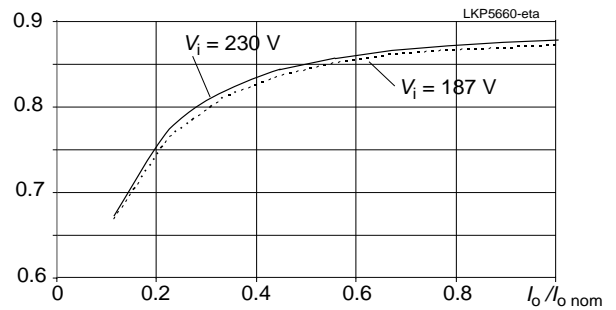

Fig. 11b
Efficiency versus output current (LKP5660-7R)

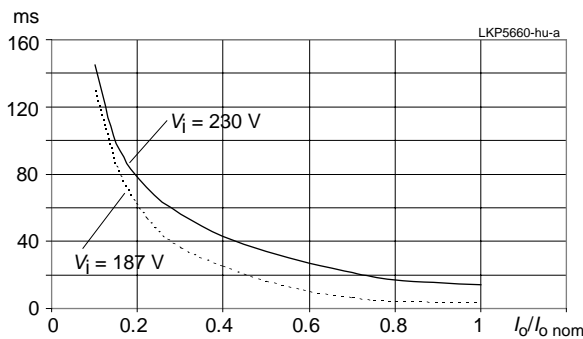

Fig. 10b
Hold-up time versus output power (LKP5660-7R)

Electrical Output Data

General Conditions:

– $T_A = 25\text{ °C}$, unless T_C is specified.

– Pin 18 (i) connected to pin 14 (S– or Vo1–), R input not connected, V_o adjusted to $V_{o\text{ nom}}$ (option P),

– Sense line pins 12 (S+) and 14 (S–) connected to pins 4 (Vo1+) and 8 (Vo1–), respectively.

Table 5: Output data of single-output models

Model		LK4002 / LK4003		LK4301 / LK4740 ⁵		LK4501		LK4601		Unit			
Nom. output voltage		5.1 V		12 V ⁵		15 V		24 V					
Characteristics		Conditions		min	typ	max	min	typ	max	min	typ	max	
V_o	Output voltage	$V_{i\text{ nom}}, I_{o\text{ nom}}$		5.07	5.13	11.93 ⁵	12.07 ⁵	14.91	15.09	23.86	24.14	V	
$V_{o\text{ BR}}$	Overvoltage protection (suppressor diode) ⁶			6		15.2/17 ⁵		19.6		28.5			
$I_{o\text{ nom}}$	Output current nom. ¹	$V_{i\text{ min}} - V_{i\text{ max}}$ $T_{C\text{ min}} - T_{C\text{ max}}$		20/25 ⁷		12/10 ⁵		10		6		A	
$I_{o\text{ L}}$	Output current limit	$V_{i\text{ min}} - V_{i\text{ max}}$		21/26 ⁷		12.2/10.2 ⁵		10.2		6.2			
V_o	Output noise ³	Low frequency	$V_{i\text{ nom}}, I_{o\text{ nom}}$		2		2		2		2		mV _{pp}
		Switching frequ.	BW = 20 MHz		15		5		5		5		
		Total incl. spikes			25		40		40		40		
$\Delta V_{o\text{ u}}$	Static line regulation with respect to $V_{i\text{ nom}}$	$V_{i\text{ min}} - V_{i\text{ max}}$ $I_{o\text{ nom}}$		±5		±12		±15		±24		mV	
$\Delta V_{o\text{ l}}$	Static load regulation	$V_{i\text{ nom}}$ $(0.1 - 1) I_{o\text{ nom}}$		–15		–25		–30		–40			
$V_{o\text{ d}}$	Dynamic load regulat. ²	Voltage deviation ²	$V_{i\text{ nom}}$ $I_{o\text{ nom}} \leftrightarrow 1/2 I_{o\text{ nom}}$		±100		±100		±100		±100		
t_d		Recovery time ²			0.3		0.4		0.4		0.3		ms
α_{V_o}	Temperature coefficient of output voltage ⁴	$T_{C\text{ min}} - T_{C\text{ max}}$ $I_{o\text{ nom}}$		±0.02		±0.02		±0.02		±0.02		%/K	

¹ If the output voltages are increased above $V_{o\text{ nom}}$ through R-input control, option P setting, remote sensing or option T, the output currents should be reduced accordingly so that $P_{o\text{ nom}}$ is not exceeded.

² See fig. 14 (Dynamic Load Regulation)

³ Measured according to IEC/EN 61204 with a probe according to annex A

⁴ For battery charger applications, a defined negative temperature coefficient can be provided by using a temperature sensor (see *Accessories*), but we recommend choosing special battery charger models.

⁵ Especially designed for battery charging using the temperature sensor; see *Accessories*. V_o is set to 12.84 V ±1% (R-input open)

⁶ Breakdown voltage of the incorporated suppressor diode (1 mA; 10 mA for 5 V output). To exceed $V_{o\text{ BR}}$ is dangerous for the suppressor diode.

⁷ 1st value for LK4002-7, 2nd value for LK4003-6

Table 6a: Output data of double-output LK models. General conditions as in table 5.

Model Nom. output voltage			LK5320 2 x 12 V				LK5540 2 x 15 V				Unit	
Characteristics		Conditions	Output 1		Output 2		Output 1		Output 2			
			min	typ	max	min	typ	max	min	typ		max
V_o	Output voltage		$V_{i\ nom}, I_{o\ nom}^1$	11.93	12.07	11.82	12.18	14.91	15.09	14.78	15.22	V
$V_{o\ BR}$	Overvoltage protection (suppressor diode) ⁸			15.2		15.2		19.6		19.6		
$I_{o\ nom}$	Output current nom. ²		$V_{i\ min} - V_{i\ max}$ $T_{C\ min} - T_{C\ max}$	6		6		5		5		A
I_{oL}	Output current limit		$V_{i\ min} - V_{i\ max}$	6.2		6.2		5.2		5.2		
v_o	Output noise ³	Low frequency	$V_{i\ nom}, I_{o\ nom}$ BW = 20 MHz	3		3		3		3		mV _{pp}
		Switching freq.		12		12		10		10		
		Total incl.spikes		70		60		80		60		
$\Delta V_{o\ u}$	Static line regulation with respect to $V_{i\ nom}$		$V_{i\ min} - V_{i\ max}$ $I_{o\ nom}$	±12		5		±15		5		mV
$\Delta V_{o\ l}$	Static load regulation ¹		$V_{i\ nom}$ (0.1 – 1) $I_{o\ nom}$	-40		5		-50		5		
$V_{o\ d}$	Dynamic load regulat. ³	Voltage deviation ⁴	$V_{i\ nom}, I_{o1\ nom} \leftrightarrow \frac{1}{2} I_{o1\ nom}$ $\frac{1}{2} I_{o2\ nom}$	±100		±150		±100		±150		
t_d		Recovery time ⁴		0.3				0.4				ms
α_{v_o}	Temperature coefficient of output voltage ⁶		$T_{C\ min} - T_{C\ max}$ $I_{o\ nom}$	±0.02				±0.02				%/K

Table 6b: Output data of double-output LK models. General conditions as in table 5.

Model Nom. output voltage			LK5660 / 5740 ⁷ 2 x 24 V / 25.68 V ⁷				Unit	
Characteristics		Conditions	Output 1		Output 2			
			min	typ	max	min		typ
V_o	Output voltage		$V_{i\ nom}, I_{o\ nom}^1$	23.86 ⁷	24.14 ⁷	23.64 ⁷	24.36 ⁷	V
$V_{o\ BR}$	Overvoltage protection (suppressor diode) ⁸			28.5/34 ⁷		28.5/34 ⁷		
$I_{o\ nom}$	Output current nom. ²		$V_{i\ min} - V_{i\ max}$ $T_{C\ min} - T_{C\ max}$	3/2.7 ⁷		3/2.7 ⁷		A
I_{oL}	Output current limit		$V_{i\ min} - V_{i\ max}$	3.2		3.2		
v_o	Output noise ³	Low frequency	$V_{i\ nom}, I_{o\ nom}$ BW = 20 MHz	3		3		mV _{pp}
		Switching freq.		10		10		
		Total incl.spikes		80		60		
$\Delta V_{o\ u}$	Static line regulation with respect to $V_{i\ nom}$ ³		$V_{i\ min} - V_{i\ max}$ $I_{o\ nom}$	±20		5		mV
$\Delta V_{o\ l}$	Static load regulation ¹		$V_{i\ nom}$ (0.1 – 1) $I_{o\ nom}$	-40		5		
$V_{o\ d}$	Dynamic load regulat. ³	Voltage deviation ⁴	$V_{i\ nom}, I_{o1\ nom} \leftrightarrow \frac{1}{2} I_{o1\ nom}$ $\frac{1}{2} I_{o2\ nom}$	±100		±150		
t_d		Recovery time ⁴		0.3				ms
α_{v_o}	Temperature coefficient of output voltage ⁶		$T_{C\ min} - T_{C\ max}$ $I_{o\ nom}$	±0.02				%/K

¹ Same conditions for both outputs

² If the output voltages are increased above $V_{o\ nom}$ via R-input control, option P setting, remote sensing or option T, the output currents should be reduced accordingly so that $P_{o\ nom}$ is not exceeded.

³ Measured according to IEC/EN 61204 with a probe annex A

⁴ See *Dynamic Load Regulation*

⁵ See *Output Voltage Regulation of Double-Output Models*

⁶ For battery charger applications a defined negative temperature coefficient can be provided by using a temperature sensor; see *Accessories*.

⁷ Especially designed for battery charging using the battery temperature sensor; see *Accessories*. V_{o1} is set to 25.68 V ±1% (R-input open).

⁸ Breakdown voltage of the incorporated suppressor diodes (1 mA). Exceeding $V_{o\ BR}$ is dangerous for the suppressor diodes.

Table 7a: Output data of double-output LKP models. General conditions as in table 5.

Model		Nom. output voltage		LKP5660-7 2× 24 V						LKP5740-7 ⁷ 2× 25.68 V				Unit	
Characteristics		Conditions		Output 1			Output 2			Output 1			Output 2		
				min	typ	max	min	typ	max	min	typ	max	min		typ
V_o	Output voltage	$V_{i\text{nom}}, I_{o\text{nom}}^1$		23.86 ⁷	24.14 ⁷		23.64 ⁷	24.36 ⁷		25.42	25.94		25.17	26.19	V
$V_{o\text{BR}}$	Overvoltage protection (suppressor diode) ⁸			28.5			28.5			34			34		
$I_{o\text{nom}}$	Output current nom. ² $T_{C\text{min}} - T_{C\text{max}}$	$V_{i\text{min}} - V_{i\text{max}}$		5.2			5.2			4.5			4.5	A	
I_{oL}	Output current limit	$V_{i\text{min}} - V_{i\text{max}}$		5.3			5.3			4.6			4.6		
v_o	Output noise ³	Low frequency	$V_{i\text{nom}}, I_{o\text{nom}}$ BW = 20 MHz	10			10			10			10	mV _{pp}	
		Switching freq.		20			20			20			20		
		Total incl.spikes		120			40			120			100		
ΔV_{oU}	Static line regulation with respect to $V_{i\text{nom}}$	$V_{i\text{min}} - V_{i\text{max}}$ $I_{o\text{nom}}$		±10			5			±10			5	mV	
ΔV_{oI}	Static load regulation (0.1 – 1) $I_{o\text{nom}}$	$V_{i\text{nom}}$		-60			5			-80			5		
v_{od}	Dynamic load regulat. ³	Voltage deviation ⁴	$V_{i\text{nom}}$ $I_{o\text{nom}} \leftrightarrow 1/2 I_{o\text{nom}}$	±150			±150			±150			±150		
t_d	Recovery time ⁴			0.3						0.4				ms	
α_{vO}	Temperature coefficient of output voltage ⁶	$T_{C\text{min}} - T_{C\text{max}}$ $I_{o\text{nom}}$		±0.02						±0.02				%/K	

¹ Same conditions for both outputs

² If the output voltages are increased above $V_{o\text{nom}}$ via R-input control, option P setting, remote sensing or option T, the output currents should be reduced accordingly so that $P_{o\text{nom}}$ is not exceeded.

³ Measured according to IEC/EN 61204 with a probe according to annex A

⁴ See *Dynamic Load Regulation*

⁵ See *Output Voltage Regulation of Double-Output Models*

⁶ For battery charger applications, a defined negative temperature coefficient can be provided by using a temperature sensor (see *Accessories*), but we recommend choosing special battery charger models.

⁷ Especially designed for battery charging using the battery temperature sensor (see *Accessories*). Similar models see table 7b. V_{o1} is set to 25.68 V ±1% (R-input open).

⁸ Breakdown voltage of the incorporated suppressor diodes (1 mA). To exceed $V_{o\text{BR}}$ is dangerous for the suppressor diodes.

Table 7b: Other LKP models

All data not specified in this table are equal to LKP5740-7. General conditions as in table 5.

Model		Nom. output voltage		LKP 5320-6 2× 12 V						LKP5661-5 ² 2× 24 V			LKP5741-5 ³ 2× 25.68 V			Unit
Characteristics		Conditions		Output 1			Output 2			Output 1, 2			Output 1, 2			
				min	typ	max	min	typ	max	min	typ	max	min		typ	max
$I_{o\text{nom}}$	Output current nom.	$V_{i\text{min}} - V_{i\text{max}}$ $T_{C\text{min}} - T_{C\text{max}}$		10			10			5.8			5	A		
I_{oL}	Output current limit ¹	$V_{i\text{min}} - V_{i\text{max}}$		10.2			10.2			6.0			5.2			
$T_{A\text{max}}$	Max. operating temp.			60						50			50	°C		

¹ Both outputs series connected

² All other data see LKP5660-7

³ All other data see LKP5740-7 (battery charger)

Thermal Considerations

If a converter is located in free, quasi-stationary air (convection cooling) at the indicated maximum ambient temperature $T_{A \max}$ (see table: *Temperature specifications*) and is operated at its nominal input voltage and output power, the temperature measured at the *Measuring point of case temperature* T_C (see: *Mechanical Data*) will approach the indicated value $T_{C \max}$ after the warm-up phase. However, the relationship between T_A and T_C depends heavily on the conditions of operation and integration into a system. The thermal conditions are influenced by input voltage, output current, airflow, and temperature of surrounding components and surfaces. $T_{A \max}$ is therefore, contrary to $T_{C \max}$, an indicative value only.

Caution: The installer must ensure that under all operating conditions T_C remains within the limits stated in the table: *Temperature specifications*.

Notes: Sufficient forced cooling or an additional heat sink (applied to -7 or -9) models allows T_A to be higher than 71 °C (e.g., 85 °C), if $T_{C \max}$ is not exceeded. Details are specified in fig. 12, including -5 and -6 models.

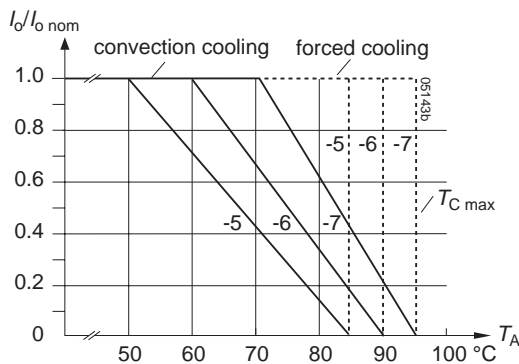

Fig. 12
Output current derating versus temperature for -5, -6, and -7 (equal to -9) models.

Thermal Protection

A temperature sensor generates an internal inhibit signal, which disables the outputs, when the case temperature exceeds $T_{C \max}$. The outputs automatically recover, when the temperature drops below this limit.

Continuous operation under simultaneous extreme worst-case conditions of the following three parameters should be avoided: Minimum input voltage, maximum output power, and maximum temperature.

Output Protection

Each output is protected by a suppressor diode against overvoltage, which could occur due to a failure of the control circuit. In such a case, the suppressor diode becomes a short circuit. The suppressor diodes may smooth short overvoltages resulting from dynamic load changes, but they are not designed to withstand externally applied overvoltages.

A short circuit at any of the two outputs will cause a shutdown of the other output. A red LED indicates any overload condition.

Note: $V_{o \text{ BR}}$ is specified in *Electrical Output Data*. If this voltage is exceeded, the suppressor diode generates losses and may become a short circuit.

Parallel or Series Connection of Converters

Single- or double-output models with equal output voltage can be connected in parallel without any precautions using option T (current sharing). If the T pins are interconnected, all converters share the output current equally.

Single-output models and/or main and second outputs of double-output models can be connected in series with any other (similar) output.

Notes:

- Parallel connection of double-output models should always include both, main and second output to maintain good regulation.
- Not more than 5 converters should be connected in parallel.
- Series connection of second outputs without involving their main outputs should be avoided, as regulation may be poor.
- Series connection of outputs totalizing more than 36 V nominal voltage need additional measures to limit the output to SELV (Safe Extra Low Voltage).
- The maximum output current is limited by the output with the lowest current limitation, if several outputs are connected in series.

Output Voltage Regulation

The following figures apply to single-output or double-output models with parallel-connected outputs.

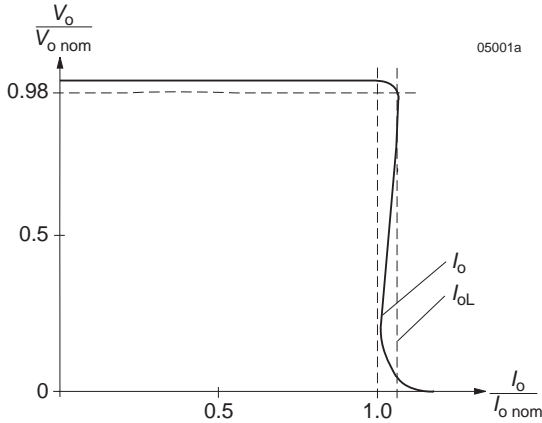

Fig. 13
Typical output characteristic V_o versus I_o .

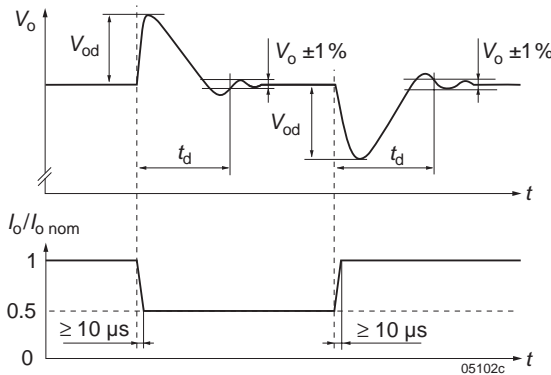

Fig. 14
Typical dynamic load regulation of V_o .

Output Regulation of Double-Output Models

Output 1 is under normal conditions regulated to $V_{o1,nom}$, independent of the output currents.

V_{o2} depends upon the load distribution. If both outputs are loaded with more than 10% of $I_{o,nom}$, the deviation of V_{o2} remains within $\pm 5\%$ of V_{o1} . The following 3 figures show the regulation with varying load distribution.

Two outputs of a double-output model connected in parallel behave like the output of a single-output model.

Note: If output 2 is not used, we recommend connecting it in parallel with output 1. This ensures good regulation and efficiency.

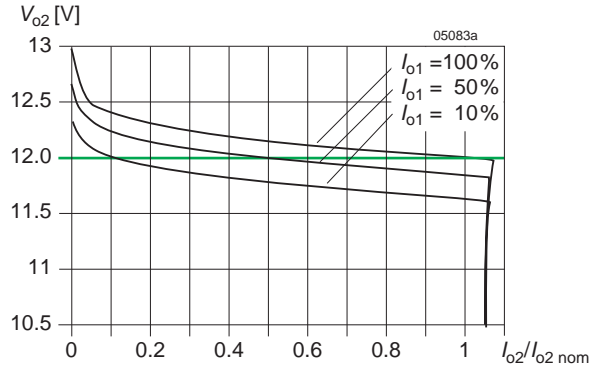

Fig. 15
Models with 2 outputs 12 V: ΔV_{o2} versus I_{o2} with various I_{o1} (typ).

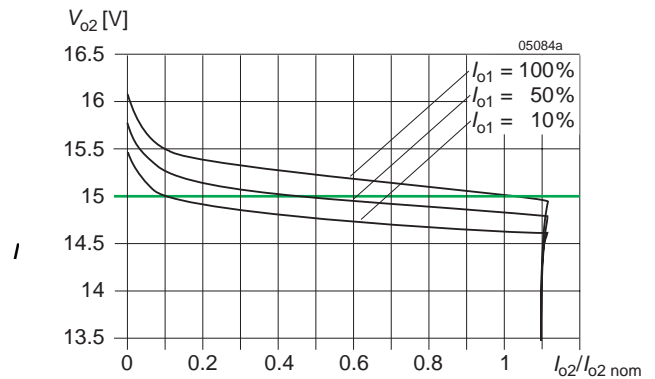

Fig. 16
Models with 2 outputs 15 V: ΔV_{o2} versus I_{o2} with various I_{o1} (typ).

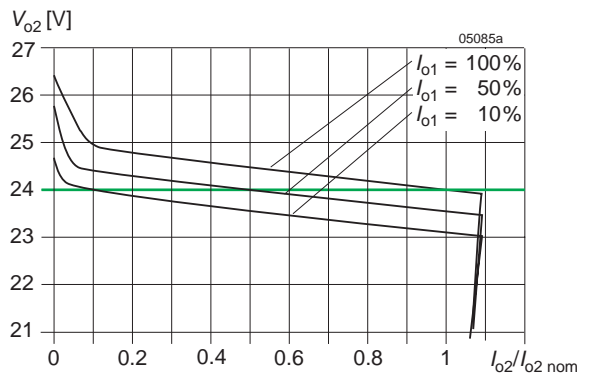

Fig. 17
Models with 2 outputs 24 V: ΔV_{o2} versus I_{o2} with various I_{o1} (typ).

Auxiliary Functions

Inhibit for Remote On/Off

The outputs may be enabled or disabled by means of a logic signal (TTL, CMOS, etc.) applied between the inhibit input i (pin 18) and pin 14 (S– or Vo1–). In systems with several converters, this feature can be used to control the activation sequence of the converters. If the inhibit function is not required, connect the inhibit pin 18 to pin 14.

Note: If pin 18 is not connected, the output is disabled.

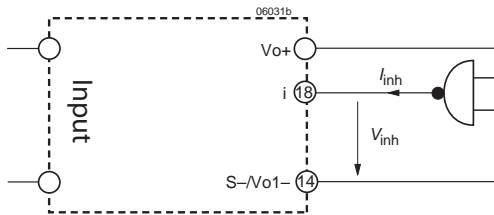

Fig. 18
Definition of V_{inh} and I_{inh} .

Table 8: Inhibit characteristics

Characteristic	Conditions	min	typ	max	Unit
V_{inh} Inhibit voltage	$V_o = \text{on}$	$V_{i \text{ min}} - V_{i \text{ max}}$	-50	0.8	V
	$V_o = \text{off}$		2.4	50	
I_{inh} Inhibit current	$V_{inh} = 0$			-400	μA
t_r Rise time			30		ms
t_f Fall time	depending on I_o				

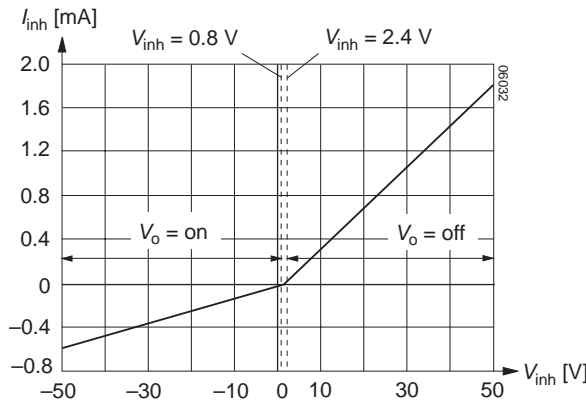

Fig. 19
Typical inhibit current I_{inh} versus inhibit voltage V_{inh}

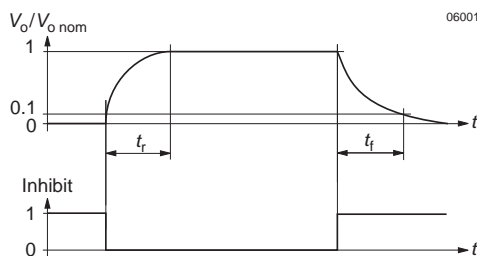

Fig. 20
Output response as a function of inhibit control

Sense Lines (Single-Output Models)

Important: Sense lines must always be connected! Incorrectly connected sense lines may activate the overvoltage protection resulting in a permanent short-circuit of the output.

This feature allows for compensation of voltage drops across the connector contacts and if necessary, across the load lines. We recommend connecting the sense lines directly at the female connector.

To ensure correct operation, both sense lines (S+, S–) should be connected to their respective power outputs (Vo+ and Vo–), and the voltage difference between any sense line and its respective power output (as measured on the connector) should not exceed the following values:

Table 9: Maximum voltage compensation allowed using sense lines

Output voltage	Total voltage difference between sense lines and their respective outputs	Voltage difference between Vo– and S–
5.1 V	<0.5 V	<0.25 V
12 V, 15 V, 24 V	<1.0 V	<0.25 V

Note: If the output voltages are increased above $V_{o \text{ nom}}$ via R-input control, option P setting, remote sensing or option T, the output currents must be reduced accordingly, so that $P_{o \text{ nom}}$ is not exceeded.

Programmable Output Voltage (R-Function)

As a standard feature, the converters offer an adjustable output voltage, identified by letter R in the type designation. The control input R (pin 16) accepts either a control voltage V_{ext} or a resistor R_{ext} to adjust the desired output voltage. When input R is not connected, the output voltage is set to $V_{o \text{ nom}}$.

a) Adjustment by means of an external control voltage V_{ext} between pin 16 (R) and pin 14:

The control voltage range is 0 – 2.75 VDC and allows an output voltage adjustment in the range of approximately 0 – 110% $V_{o \text{ nom}}$.

$$V_{ext} \approx \frac{V_o}{V_{o \text{ nom}}} \cdot 2.5 \text{ V}$$

b) Adjustment by means of an external resistor:

Depending upon the value of the required output voltage the resistor shall be connected

either: Between pin 16 and pin 14 ($V_o < V_{o \text{ nom}}$) to achieve an output voltage adjustment range of approximately 0 – 100% $V_{o \text{ nom}}$.

or: Between pin 16 and pin 12 ($V_o > V_{o \text{ nom}}$) to achieve an output voltage adjustment range of 100 – 110% $V_{o \text{ nom}}$.

Warning:

- V_{ext} shall never exceed 2.75 V.
- The value of R_{ext} shall never be less than the lowest value as indicated in table R_{ext} (for $V_o > V_{o \text{ nom}}$) to prevent the converter from damage!

Notes:

- The R-Function excludes option P (output voltage adjustment by potentiometer).
If the output voltages are increased above $V_{o\ nom}$ via R-input control, option P setting, remote sensing, or option T, the output currents should be reduced, so that $P_{o\ nom}$ is not exceeded.
- With double-output models the second output follows the value of the controlled main output.
- In case of parallel connection the output voltages should be individually set within a tolerance of 1 – 2%.

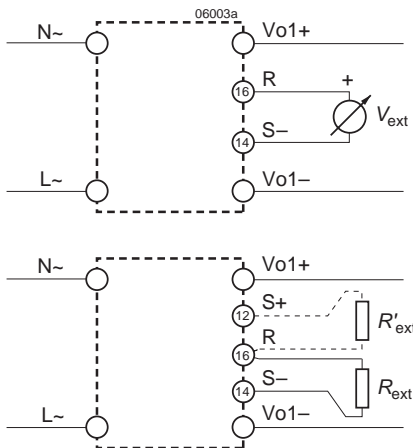

Fig. 21
Output voltage control for single-output models

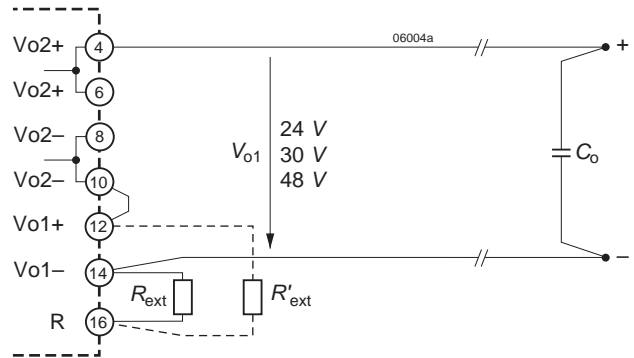

Fig. 22
Double-output models:
Wiring of the R-input for output voltages 24 V, 30 V, or 48 V with both outputs in series. A ceramic capacitor (C_o) across the load reduces ripple and spikes.

Test Jacks

Test jacks (pin diameter 2 mm) for measuring the main output voltage V_o or V_{o1} are located at the front of the converter. The positive test jack is protected by a series resistor (see: *Functional Description, block diagrams*).

The voltage measured at the test jacks is slightly lower than the value at the output terminals.

Table 10: R_{ext} for $V_o < V_{o\ nom}$; approximate values ($V_{i\ nom}$, $I_{o\ nom}$, series E 96 resistors); R'_{ext} = not fitted

$V_{o\ nom} = 5.1\ V$		$V_{o\ nom} = 12\ V$			$V_{o\ nom} = 15\ V$			$V_{o\ nom} = 24\ V$		
V_o [V]	R_{ext} [k Ω]	V_o [V] ¹		R_{ext} [k Ω]	V_o [V] ¹		R_{ext} [k Ω]	V_o [V] ¹		R_{ext} [k Ω]
0.5	0.432	2	4	0.806	2	4	0.619	4	8	0.806
1.0	0.976	3	6	1.33	4	8	1.47	6	12	1.33
1.5	1.65	4	8	2	6	12	2.67	8	16	2
2.0	2.61	5	10	2.87	8	16	4.53	10	20	2.87
2.5	3.83	6	12	4.02	9	18	6.04	12	24	4.02
3.0	5.76	7	14	5.62	10	20	8.06	14	28	5.62
3.5	8.66	8	16	8.06	11	22	11	16	32	8.06
4.0	14.7	9	18	12.1	12	24	16.2	18	36	12.1
4.5	30.1	10	20	20	13	26	26.1	20	40	20
5.0	200	11	22	42.2	14	28	56.2	22	44	44.2

Table 10b: R'_{ext} for $V_o > V_{o\ nom}$; approximate values ($V_{i\ nom}$, $I_{o\ nom}$, series E 96 resistors); R_{ext} = not fitted

$V_{o\ nom} = 5.1\ V$		$V_{o\ nom} = 12\ V$			$V_{o\ nom} = 15\ V$			$V_{o\ nom} = 24\ V$		
V_o [V]	R'_{ext} [k Ω]	V_o [V] ¹		R'_{ext} [k Ω]	V_o [V] ¹		R'_{ext} [k Ω]	V_o [V] ¹		R'_{ext} [k Ω]
5.15	432	12.1	24.2	1820	15.2	30.4	1500	24.25	48.5	3320
5.2	215	12.2	24.4	931	15.4	30.8	768	24.5	49.0	1690
5.25	147	12.3	24.6	619	15.6	31.2	523	24.75	49.5	1130
5.3	110	12.4	24.8	475	15.8	31.6	392	25.0	50.0	845
5.35	88.7	12.5	25.0	383	16.0	32.0	316	25.25	50.5	698
5.4	75	12.6	25.2	316	16.2	32.4	267	25.5	51.0	590
5.45	64.9	12.7	25.4	274	16.4	32.8	232	25.75	51.5	511
5.5	57.6	12.8	25.6	243	16.5	33.0	221	26.0	52.0	442
		13.0	26.0	196				26.25	52.5	402
		13.2	26.4	169				26.4	52.8	383

¹ First column: V_o or V_{o1} ; second column: double-output models with outputs in series connection

Display Status of LEDs

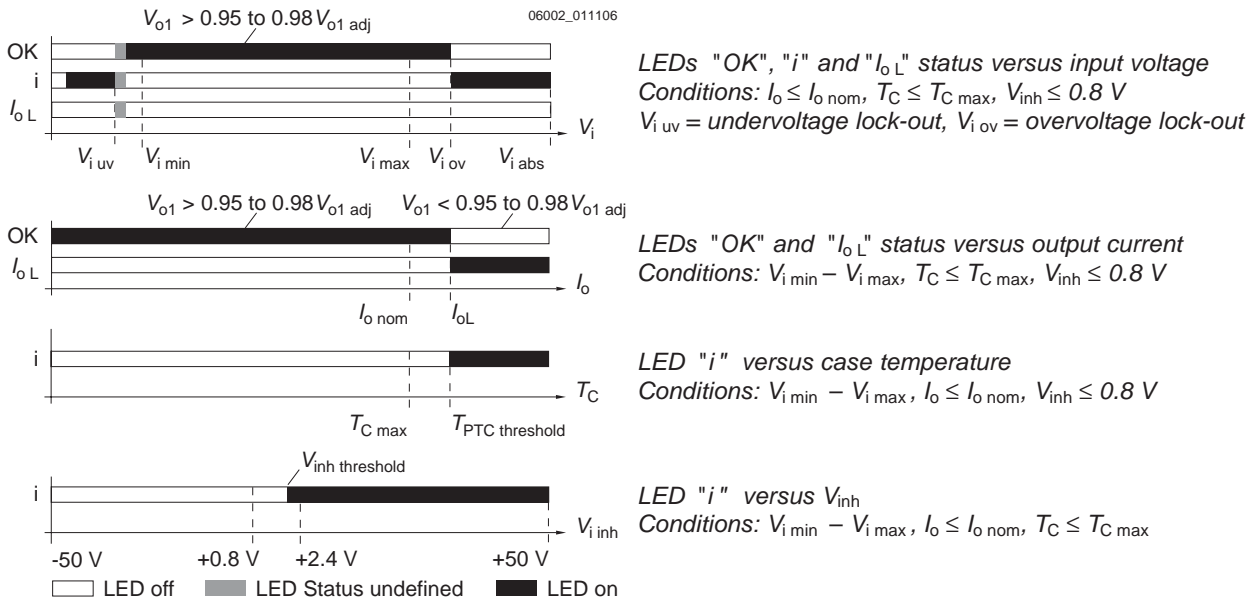

Fig. 23
LED indicators

Battery Charging / Temperature Sensor

All converters with an R-input are suitable for battery charger applications, but we recommend to choose the models especially designed for this application, see *Model Selection*, table 2.

For optimal battery charging and life expectancy of the battery an external temperature sensor can be connected to the R-input. The sensor is mounted as close as possible to the battery and adjusts the output voltage according to the battery temperature.

Depending upon cell voltage and the temperature coefficient of the battery, different sensor types are available, see *Accessories*.

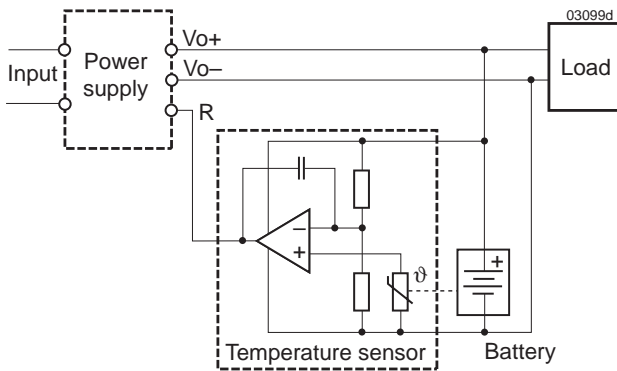

Fig. 24
Connection of a temperature sensor

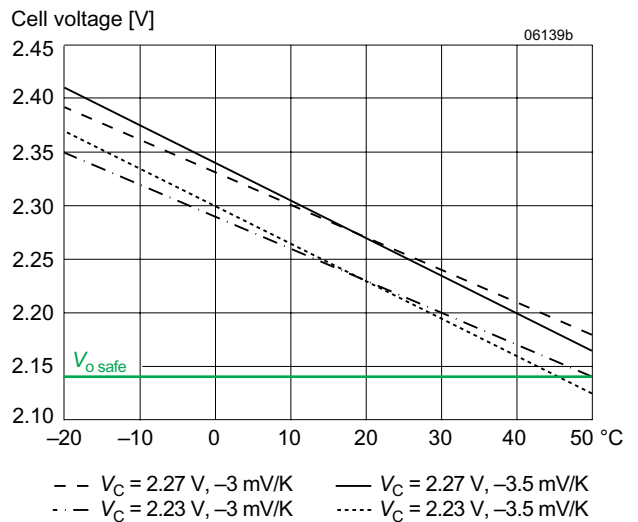

Fig. 25
Trickle charge voltage versus temperature for defined temperature coefficient. $V_{o\text{ nom}}$ is the output voltage with open R-input.

Electromagnetic Compatibility (EMC)

A metal oxide VDR together with an input fuse and an input filter form an effective protection against high input

transient voltages, which typically occur in most installations. The converters have been successfully tested to the following specifications:

Immunity

Table 11: Electromagnetic immunity (type tests)

Phenomenon	Standard	Level	Coupling mode ¹	Value applied	Waveform	Source imped.	Test procedure	In oper.	Perf. crit. ²
Electrostatic discharge (to case)	IEC/EN 61000-4-2	4	contact discharge	8000 V _p	1/50 ns	330 Ω 150 pF	10 positive and 10 negative discharges	yes	A
			air discharge	15000 V _p					
Electromagnetic field	IEC/EN 61000-4-3	3	antenna	10 V/m	AM 80% 1 kHz	n.a.	80 – 1000 MHz	yes	A
				10 V/m	50% duty cycle, 200 Hz repetition frequency	n.a.	900 ±5 MHz pulse modul.	yes	A
Electrical fast transients/burst	IEC/EN 61000-4-4	3	capacitive, o/c	±2000 V _p	bursts of 5/50 ns 2.5/5 kHz over 15 ms; burst period: 300 ms	50 Ω	60 s positive 60 s negative transients per coupling mode	yes	A
			±i/c, +i/-i direct						
Surges	IEC/EN 61000-4-5	3	±i/c	±2000 V _p	1.2/50 μs	12 Ω	5 pos. and 5 neg. surges per coupling mode	yes	A ³
			+i/-i			2 Ω			
Conducted disturbances	IEC/EN 61000-4-6	3	i, o, signal wires	10 VAC (140 dBμV)	AM 80% 1 kHz	150 Ω	0.15 – 80 MHz sine wave	yes	A
Voltage dips, short interruptions and variations	IEC/EN 6100-4-11	40%	+i/-i	230 → 92 → 230	2 → 1 → 2 s	n.a.		yes	B ⁴
		0%	+i/-i	230 → 0 → 230					B ⁴

¹ i = input, o = output, c = case

² A = Normal operation, no deviation from specifications, B = Normal operation, temporary loss of function or deviation from specs possible

³ For converters with version V102 or higher. Older LKP models meet only B.

⁴ Only LKP models have been tested.

Emissions

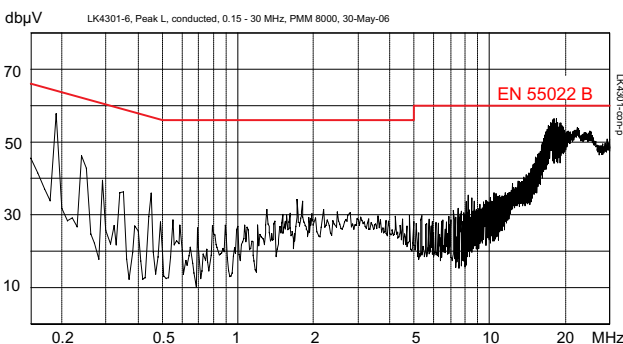

Fig. 26a
Conducted emissions (peak) at the phase input according to EN 55011/22, measured at $V_{in,nom}$ and $I_{o,nom}$ (LK4301-7R). The neutral line performs quite similar.

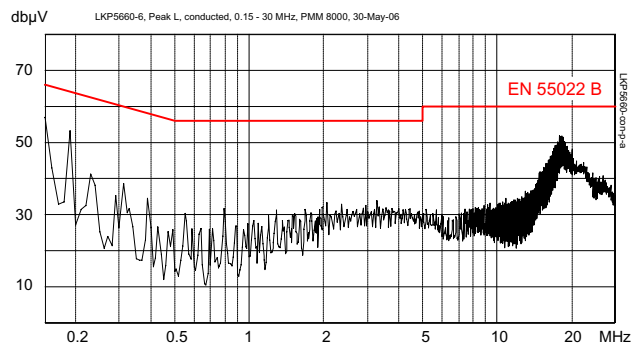

Fig. 26b
Conducted emissions (peak) at the phase input according to EN 55011/22, measured at $V_{in,nom}$ and $I_{o,nom}$ (LKP5660-7R). The neutral line performs quite similar.

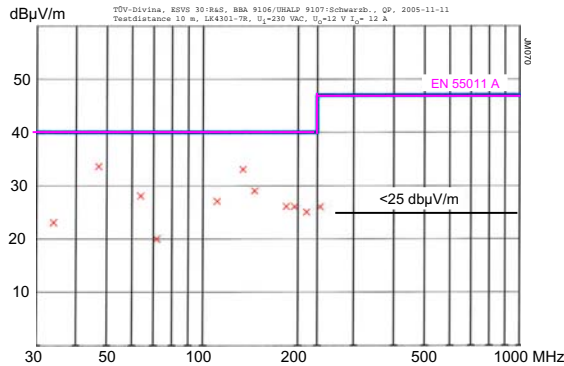

Fig. 27
Typ. radiated emissions accord. to EN 55011/22, antenna
10 m distance, measured at $V_{i\text{nom}}$ and $I_{o\text{nom}}$ (LK4301-7R).

Environmental Conditions

Table 12: Mechanical and climatic stress

Test	Method	Standard	Test Conditions	Status
Cab	Damp heat steady state	IEC/EN 60068-2-78:2001 MIL-STD-810D sect. 507.2	Temperature: $40 \pm 2^\circ\text{C}$ Relative humidity: $93^{+2/-3}\%$ Duration: 56 days	Converter not operating
Ea	Shock (half-sinusoidal)	IEC/EN 60068-2-27:1987 MIL-STD-810D sect. 516.3	Acceleration amplitude: $100\text{ g}_n = 981\text{ m/s}^2$ Bump duration: 6 ms Number of bumps: 18 (3 each direction)	Converter operating
Eb	Bump (half-sinusoidal)	IEC/EN 60068-2-29:1987 MIL-STD-810D sect. 516.3	Acceleration amplitude: $40\text{ g}_n = 392\text{ m/s}^2$ Bump duration: 6 ms Number of bumps: 6000 (1000 each direction)	Converter operating
Fc	Vibration (sinusoidal)	IEC/EN 60068-2-6:1995 MIL-STD-810D sect. 514.3	Acceleration amplitude: 0.35 mm (10 – 60 Hz) $5\text{ g}_n = 49\text{ m/s}^2$ (60 – 2000 Hz) Frequency (1 Oct/min): 10 – 2000 Hz Test duration: 7.5 h (2.5 h each axis)	Converter operating
Fh	Random vibration broad band (digital control)	IEC/EN 60068-2-64	Acceleration spectral density: $0.05\text{ g}_n^2/\text{Hz}$ Frequency band: 8 – 500 Hz Acceleration magnitude: $4.9\text{ g}_{n\text{rms}}$ Test duration: 1.5 h (0.5 h each axis)	Converter operating
Kb	Salt mist, cyclic (sodium chloride NaCl solution)	IEC/EN 60068-2-52:1996	Concentration: 5% (30 °C) Duration: 2 h per cycle Storage: 40 °C, 93% rel. humidity Storage duration: 22 h per cycle Number of cycles: 3	Converter not operating

Temperatures

Table 13: Temperature specifications, values given are for an air pressure of 800 – 1200 hPa (800 – 1200 mbar)

Temperature			-5		-6		-7		-9		Unit
Characteristics	Conditions	min	max	min	max	min	max	min	max		
T_A	Ambient temperature	Converter operating	-25^1	50	-25^1	60	-25	71	-40	71	°C
T_C	Case temperature ¹		-25^1	85^3	-25^1	90^3	-25	95^3	-40	95^3	
T_S	Storage temperature	Not operating	-40^2	100	-40^2	100	-40	100	-55	100	

¹ Minimum T_A and T_C for models with option E is -40°C .

² Minimum T_S for models with option E is -55°C .

³ Overtemperature lockout at $T_C \geq 95^\circ\text{C}$.

Reliability

Table 14: MTBF calculated according to MIL-HDBK 217F

Values at specified case temperature	Model	Ground benign 40 °C		Ground fixed 40 °C 70 °C		Ground mobile 50 °C	Unit
		514 000	88 000	38 000	35 000		
MTBF	LK4301-7ER						h

Mechanical Data

Dimensions in mm. The converters are designed to be inserted into a 19" rack, 160 mm long, according to IEC 60297-3.

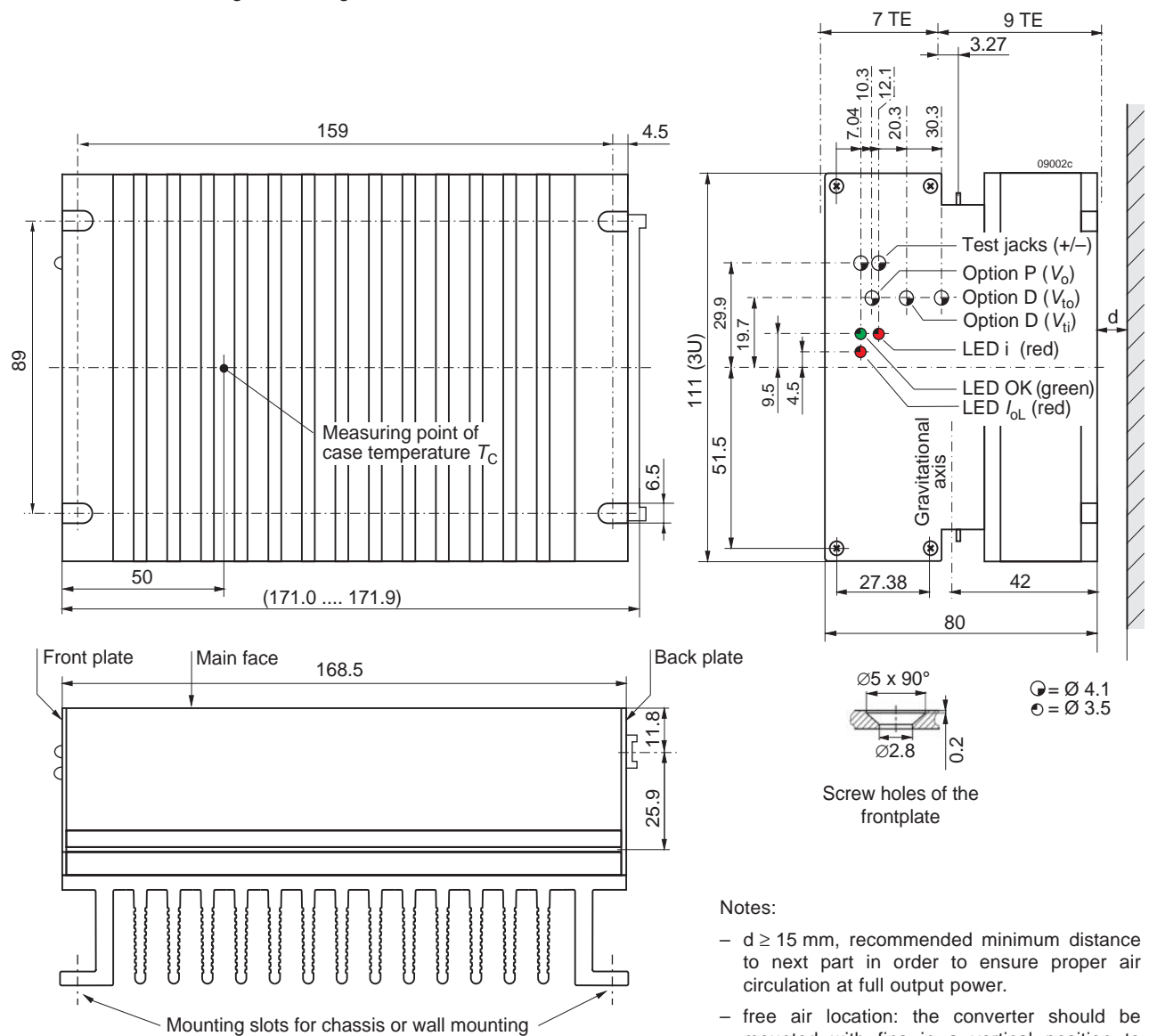

Fig. 28
Aluminium case K02 with heat sink, black finish (EP powder coated), and self cooling; weight ≈ 1.6 kg

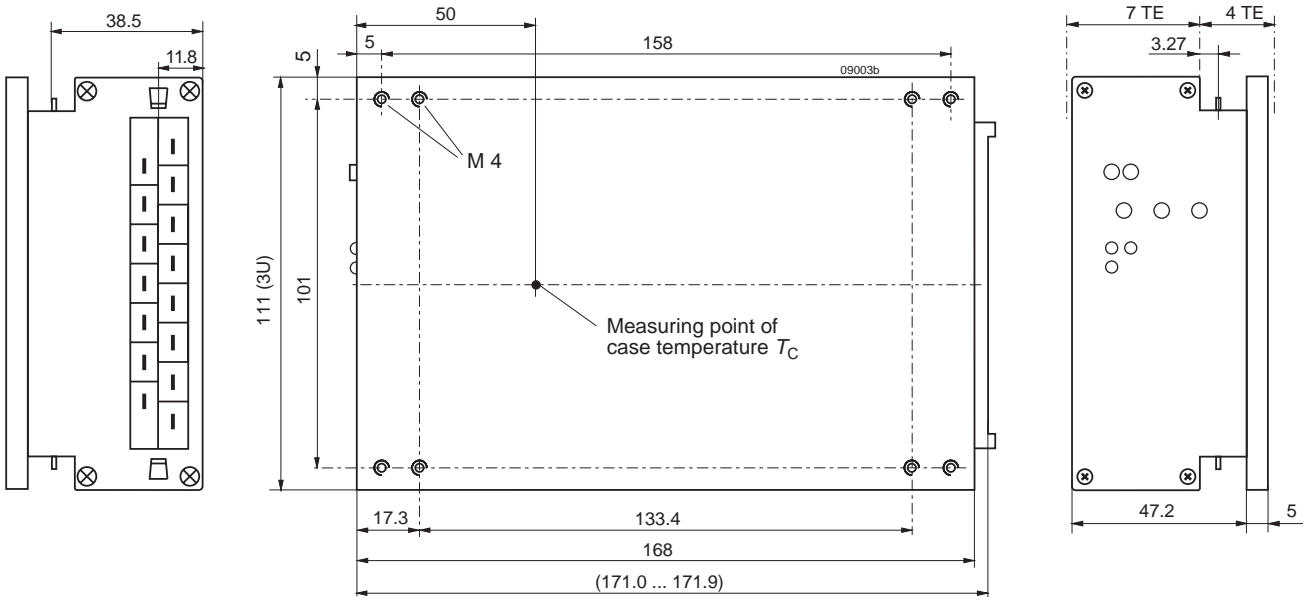

Fig. 29
Option B1: Aluminium case K02 with small cooling plate; black finish (EP powder coated).
Suitable for mounting with access from the backside.
Total weight approx. 1.2 kg.



Note: Long case with option B2, elongated by 60 mm for 220 mm rack depth, is available on request. (No LEDs, no test jacks.)

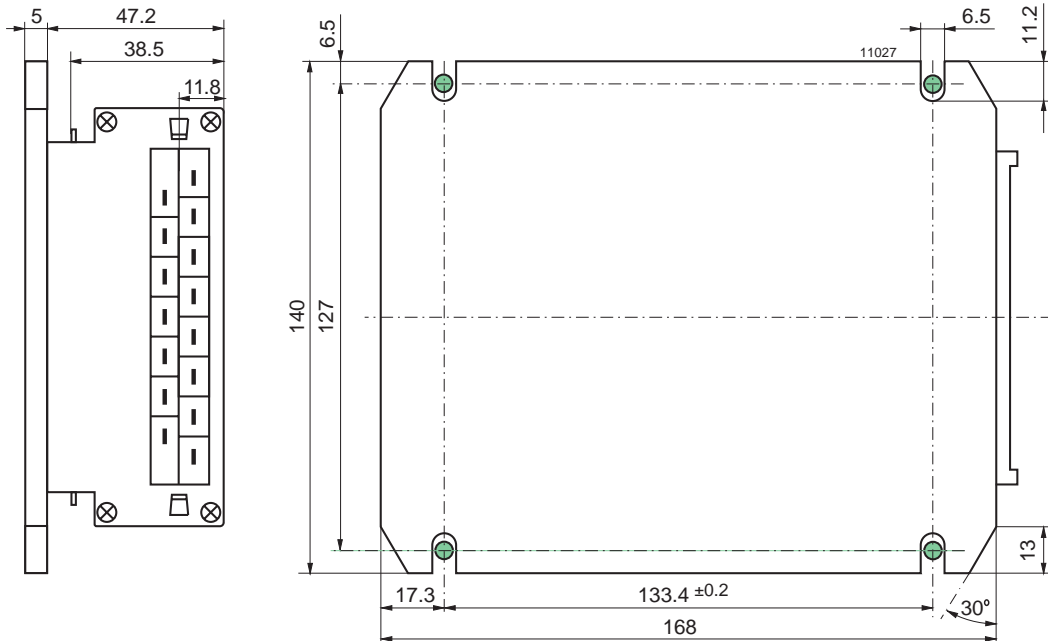

Fig. 30
Option B: Aluminium case K02 with large cooling plate; black finish (EP powder coated).
Suitable for front mounting.
Total weight approx. 1.3 kg

Safety and Installation Instructions

Connector Pin Allocation

The connector pin allocation table defines the electrical potentials and the physical pin positions on the H15 connector. The protective earth is connected by a leading pin (no. 24), ensuring that it makes contact with the female connector first. Installation Instructions

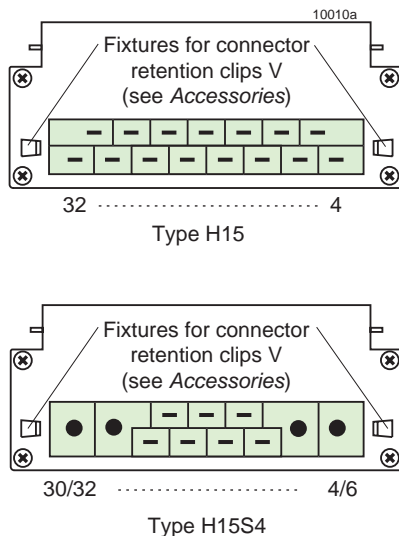

Fig. 31a
View of converter's male standard H15 connector and the connector H15S4 (models with option K)

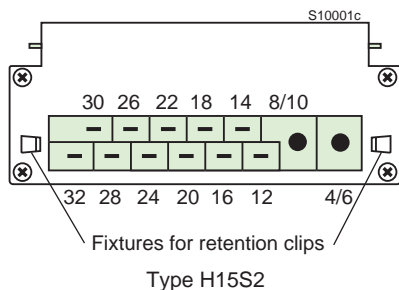

Fig. 31b
View of converter's male connector H15S2 (not for new designs). Use option K!

Table 15: Pin allocation

Pin no.	Connector H15S2/S4 ⁵		Connector type H15			
	LK4003 ($V_o = 5.1$ V)		LK4000 ($V_o \geq 5.1$ V)		LK/LKP5000	
4	Vo+	Positive output	Vo+	Positive output	Vo2+	Pos. output 2
6						
8	Vo-	Negative output	Vo-	Negative output	Vo2-	Neg. output 2
10						
12	S+	Sense+	S+	Sense+	Vo1+	Pos. output 1
14	S-	Sense-	S-	Sense-	Vo1-	Neg. output 1
16	R ¹	Control of V_o	R ¹	Control of V_o	R ¹	Control of V_{o1}
18	i	Inhibit	i	Inhibit	i	Inhibit
20	D ³	Save data	D ³	Save data	D ³	Save data
		ACFAIL				
22	T ⁴	Current share	T ⁴	Current share	T ⁴	Current share
24 ²	⊕	Protective earth	⊕	Protective earth	⊕	Protective earth
26	N~	Neutral line	N~	Neutral line	N~	Neutral line
28						
30	L~	Phase line	L~	Phase line	L~	Phase line
32						

¹ Not connected, if option P is fitted.

² Leading pin (pre-connecting)

³ Option D excludes option V and vice versa. Pin not connected, unless option D or V is fitted.

⁴ Not connected, unless option T is fitted.

⁵ Option K stands for the H15S4 connector (compatibility with LK1001)

Installation Instructions

Note: These converters have a power factor correction (PFC). The LK4000/5000 models are intended to replace the LK1000 and LK2000 converters in order to comply with IEC/EN 61000-3-2. LK1000 is replaced by LK4003 with option K.

Switch off the system and check for hazardous voltages before altering any connection!

These converters are components, intended exclusively for inclusion within other equipment by an industrial assembly operation or by professional installers. Installation must strictly follow the national safety regulations in compliance with the enclosure, mounting, creepage, clearance, casualty, markings, and segregation requirements of the end-use application.

Connection to the system shall be made via the matching H15 female connector H15; see *Accessories*. Other installation methods may not meet the safety requirements.

Pin no. 24 (⊕) is reliably connected with the case. For safety reasons it is essential to connect this pin reliably to protective earth. See *Safety of Operator-Accessible Output Circuits*.

The phase input 30/32 (L~) is connected via a built-in fuse (see *Input Fuse* and table 4), which is designed to protect in the case of a converter failure.

An additional external fuse, suitable for the application, might be necessary in the wiring to the other line input 26/28 (N₋) if:

- Local requirements demand an individual fuse in each source line
- Phase and neutral of the mains are not defined or cannot be assigned to the corresponding terminals (L₋ to phase and N₋ to neutral).
- Neutral and earth impedance is high or undefined

Notes:

- If the inhibit function is not used, pin no. 18 (i) should be connected to pin no. 14 (S-/Vo1-) to enable the output(s).
- Do not open the converters, or warranty will be invalidated.
- Due to high current values, the converters provide two internally parallel contacts for certain paths (pins 4/6, 8/10, 26/28 and 30/32). It is recommended to use both female contacts in parallel connection order to keep the voltage drop and the temperature of the contacts low.
- If the second output of double-output models is not used, connect it in parallel with the main output.

Make sure that there is sufficient airflow available for convection cooling. This should be verified by measuring the case temperature, when the converter is installed and operated in the end-use application; see *Thermal Considerations*.

Ensure that a converter failure (e.g., an internal short-circuit) does not result in a hazardous condition; see also *Safety of Operator-Accessible Output Circuits*.

Standards and Approvals

The converters are safety-approved to EN/IEC 60950-1, and UL/CSA 60950-1 2nd Ed. (version 106 or greater).

The converters correspond to Class I equipment and have been evaluated for:

- Building-in
- Basic insulation between input and case based on 250 VAC, and double or reinforced insulation between input and output(s).
- Functional insulation between outputs.

Table 17: Isolation

Characteristic		Input to case and output(s)	Output(s) to case	Output 1 to output 2	Unit
Electric strength test	Factory test >1 s	2.8 ¹	1.4	0.15	kVDC
	AC test voltage equivalent to factory test	2.0	1.0	0.1	kVAC
Insulation resistance at 500 VDC		>300	>300	>100 ²	MΩ
Creepage distances		≥3.2 ³	--	--	mm

¹ According to EN 50116 and IEC/EN 60950, subassemblies connecting input to output are pre-tested with 5.6 kVDC or 4 kVAC.

² Tested at 150 VDC

³ Input to outputs: 6.4 mm

- Overvoltage category II
- Pollution degree 2 environment
- Max. altitude: 2000 m.
- The converters fulfill the requirements of a fire enclosure.

All boards of the converters are coated with a protective lacquer.

The converters are subject to manufacturing surveillance in accordance with the above mentioned UL standards and ISO 9001:2000. A CB-scheme is available.

Cleaning Agents

In order to avoid possible damage, any penetration of cleaning fluids is to be prevented, since the power supplies are not hermetically sealed.

Protection Degree

Condition: Female connector fitted to the converter.

- IP 30: All models except those with option P, and except those with option D or V including a potentiometer.
- IP 20: All models fitted with option P, or with option D or V with potentiometer.

Leakage Currents

Leakage currents flow due to internal leakage capacitances and Y-capacitors. The current values are proportional to the supply voltage and are specified in the table below.

Table 16: Leakage currents

Characteristic		Class I	Unit
Maximum earth leakage current	Permissible according to IEC/EN 60950	3.5	mA
	Typ. value at 254 V, 50 Hz (LK models)	0.8	
	Typ. value at 254 V, 50 Hz (LKP models)	0.8	

Isolation

The electric strength test is performed in the factory as routine test in accordance with EN 50116 and IEC/EN 60950 and should not be repeated in the field. Power-One will not honor any warranty claims resulting from electric strength field tests.

Safety of Operator-Accessible Output Circuits

If the output circuit of a converter is operator-accessible, it shall be an SELV circuit according to IEC/EN 60950.

The table below shows a possible installation configuration, compliance with which causes the output circuit of a K Series AC-DC converter to be a SELV circuit according to IEC/EN 60950 up to a configured output voltage of 36 V (sum of nominal voltages connected in series) .

However, it is the sole responsibility of the installer to ensure compliance with the applicable safety regulations.

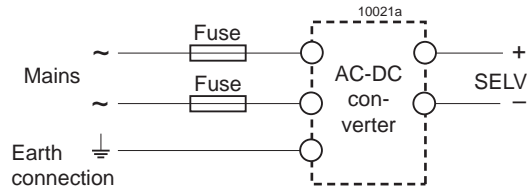

Fig. 32
Schematic safety concept.

Table 18: Safety concept leading to a SELV output circuit

Conditions	AC-DC converter	Installation	Result
Nominal voltage	Grade of insulation between input and output provided by the AC-DC converter	Measures to achieve the resulting safety status of the output circuit	Safety status of the AC-DC converter output circuit
Mains ≤ 250 VAC	Double or reinforced	Earthed case ¹ and installation according to the applicable standards	SELV circuit

¹ The earth connection has to be provided by the installer according to the relevant safety standards, e.g., IEC/EN 60950.

Description of Options

Table 19: Survey of options

Option	Function of option	Characteristic
-9	Extended operational ambient temperature range	$T_A = -40$ to 71 °C
E	Electronic inrush current limitation circuitry	Active inrush current limitation
P ²	Potentiometer for fine adjustment of output voltage	Adjustment range $+10/-60\%$ of $V_{o\ nom}$, excludes R input
D ¹	Input and/or output undervoltage monitoring circuitry	Safe data signal output (D0 – DD)
V ¹	Input and/or output undervoltage monitoring circuitry	ACFAIL signal according to VME specifications (V0, V2, V3)
T	Current sharing	Interconnect T-pins if paralleling outputs (max 5 converters)
K	H15S4 connector for models with 5.1 V output	For new designs; provides compatibility with LK1001 models
B, B1, B2	Cooling plate (160 or 220 mm long)	Replaces standard heat sink, allowing direct chassis-mounting
G	RoHS-compliant for all six substances	G is always the last character in the type designation

¹ Option D excludes option V and vice versa; option V only for 5.1 V outputs.

² Option P is not available for battery charger models.

-9 Extended Temperature Range

Option -9 extends the operational ambient temperature range from -25 to 71 °C (standard) to -40 to 71 °C. The power supplies provide full nominal output power with convection cooling. Option -9 excludes inrush current limitation by NTC.

E Inrush Current Limitation

The converters exhibit an electronic circuit replacing the standard built-in NTC, in order to achieve an enhanced inrush current limiting function.

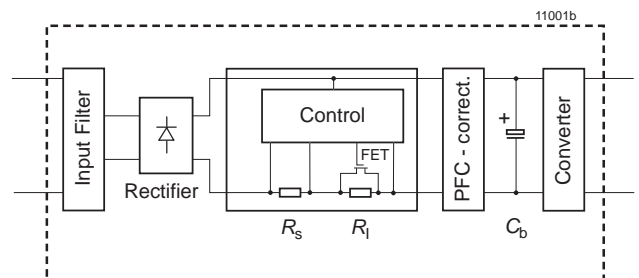

Fig. 33
Option E block diagram

Note: Subsequent switch-on cycles at start-up are limited to max. 10 cycles during the first 20 seconds (cold converter) and then to max. 1 cycle every 8 s.

Table 20: Inrush current characteristics with option E

Characteristics $V_i = 230 \text{ VAC}$		all models typ max		Unit
$I_{\text{inr p}}$	Peak inrush current	–	25.3	A
t_{inr}	Inrush current duration	35	50	ms

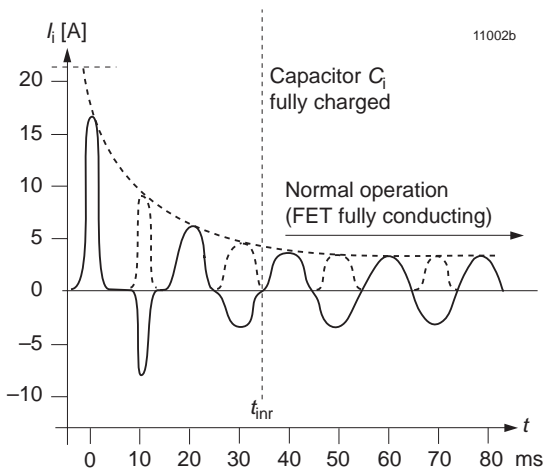

Fig. 34
Typ. inrush current with option E
 $V_i = 230 \text{ VAC}$, $f_i = 50 \text{ Hz}$, $P_o = P_{o \text{ nom}}$

P Potentiometer

A potentiometer provides an output voltage adjustment range of +10/–60% of $V_{o \text{ nom}}$. It is accessible through a hole in the front cover. Option P is not available for battery charger models and is not recommended for converters connected in parallel.

Option P excludes the R-function. With double-output models, both outputs are influenced by the potentiometer setting (doubling the voltage, if the outputs are in series).

If the output voltages are increased above $V_{o \text{ nom}}$ via R input control, option P setting, remote sensing, or option T, the output current(s) should be reduced accordingly, so that $P_{o \text{ nom}}$ is not exceeded.

T Current Sharing

This option ensures that the output currents are approximately shared between all parallel-connected converters, hence increasing system reliability. To use this facility, simply interconnect the T pins of all converters and make sure that the reference for the T signal

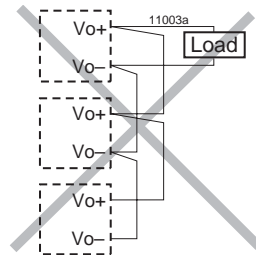
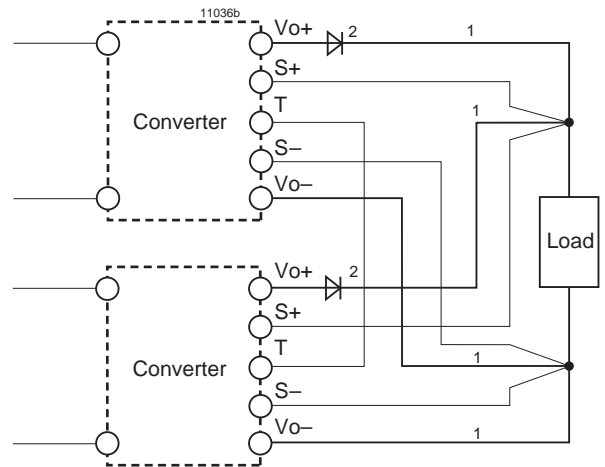

Fig. 35
Example of poor wiring for connection in parallel

(pin 14: S– or Vo1–), are also connected together. The load lines should have equal length and cross section to ensure equal voltage drops.

Not more than 5 converters should be connected in parallel. The R pins should be left open-circuit. If not, the output voltages must be individually adjusted prior to paralleling within 1 to 2% or the R pins should be connected together.

Parallel connection of converters with option P is not recommended.



Max. 5 converters in parallel connection

- ¹ Lead lines should have equal length and cross section, and should run in the same cable loom.
- ² Diodes recommended in redundant operation only

Fig. 36
Paralleling of single-output models using option T with the sense lines connected at the load

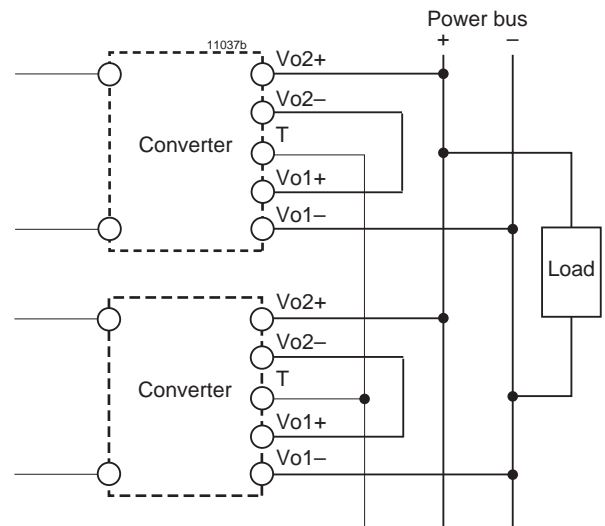

Max. 5 converters in parallel connection

Fig. 37
Paralleling of double-output models with the outputs connected in series, and using option T with power bus. The signal at the T pins is referenced to Vo1–.

Table 21: Undervoltage monitoring functions

Output type		Monitoring		Minimum adjustment range of threshold level V_t		Typical hysteresis V_{ho} [% of V_t for $V_{tmin} - V_{tmax}$]
JFET	NPN	V_b^4	V_o/V_{o1}	V_{tb}^4	V_{to}	
D1	D5	no	yes	-	$3.5 - V_{BR}^1$	2.5 – 0.6 V
D2	D6	yes	no	355 VDC	-	-
D3	D7	yes	yes	355 VDC	$(0.95 - 0.985 V_{o1})^2$	"0"
D4	D8	no	yes	-	$(0.95 - 0.985 V_{o1})^2$	"0"
D0	D9	no	yes	-	$3.5 - V_{BR}^3$	2.5 – 0.6 V
		yes	yes	355 VDC	$3.5 - V_{BR}^3$	2.5 – 0.6 V
	DD	yes	yes	355 VDC	$3.5 - V_{BR}^1$	2.5 – 0.6 V

¹Threshold level adjustable by potentiometer. See *Output Data* for V_{BR} .

² Fixed value. Tracking if V_{o1} is adjusted via R-input, option P, or sense lines.

³ The threshold level permanently adjusted according to customer specification $\pm 2\%$ at 25 °C. Any value within the specified range is basically possible, but causes a special type designation in addition to the standard option designations (D0/D9).

⁴ V_b is the voltage generated by the boost regulator. When V_b drops below 355 V, the D signal triggers, and the output(s) will remain powered during nearly the full hold-up time t_h .

D Undervoltage Monitor

The input and/or output undervoltage monitoring circuit operates independently of the built-in input undervoltage lockout circuit. A logic "low" (self conducting JFET) or "high" signal (NPN output) is generated at the D output (pin 20), when one of the monitored voltages drops below the preselected threshold level V_t . This signal is referenced to S-/Vo1-. The D output recovers, when the monitored voltages exceed $V_t + V_h$. The threshold level V_{bi} is adjusted in the factory. The threshold level V_{to} is either adjusted by a potentiometer accessible through a hole in the front cover, or adjusted in the factory to a fixed value specified by the customer.

Option D exists in various versions D0 – DD, as shown in the table below.

JFET output (D0 – D4):

Pin D is internally connected via the drain-source path of a JFET (self-conducting type) to the negative potential of output 1. $V_D \leq 0.4$ V (logic low) corresponds to a monitored voltage level (V_i and/or V_{o1}) $< V_t$. The current I_D through the JFET should not exceed 2.5 mA. The JFET is protected by a 0.5 W Zener diode of 8.2 V against external overvoltages.

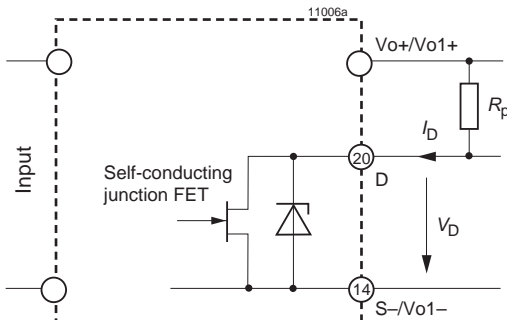

Fig. 38
Option D0 – D4: JFET output, $I_D \leq 2.5$ mA

Table 22: JFET output (D0 – D4)

V_b, V_{o1} status	D output, V_D
V_b or $V_{o1} < V_t$	low, L, $V_D \leq 0.4$ V at $I_D = 2.5$ mA
V_b and $V_{o1} > V_t + V_h$	high, H, $I_D \leq 25$ μ A at $V_D = 5.25$ V

NPN output (D5 – DD):

Pin D is internally connected via the collector-emitter path of a NPN transistor to the negative potential of output 1. $V_D < 0.4$ V (logic low) corresponds to a monitored voltage level (V_i and/or V_{o1}) $> V_t + V_h$. The current I_D through the open collector should not exceed 20 mA. The NPN output is not protected against external overvoltages. V_D should not exceed 40 V.

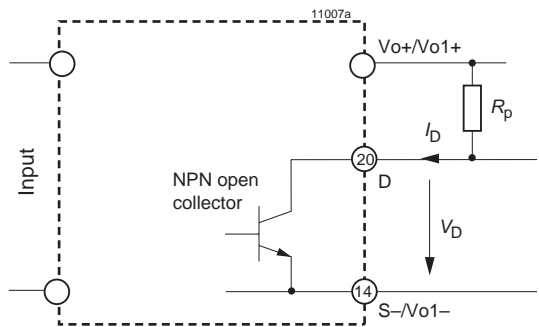

Fig. 39
Option D5 – DD: NPN output, $V_{o1} \leq 40$ V, $I_D \leq 20$ mA

Table 23: JFET output (D5 – DD)

V_b, V_{o1} status	D output, V_D
V_b or $V_{o1} < V_t$	high, H, $I_D \leq 25$ μ A at $V_D = 40$ V
V_b and $V_{o1} > V_t + V_h$	low, L, $V_D \leq 0.4$ V at $I_D = 20$ mA

Table 24: D-output logic signals

Version of D	$V_b < V_t$ resp. $V_o < V_t$	$V_b > V_t + V_h$ resp. $V_o > V_t$	Configuration
D1, D2, D3, D4, D0	low	high	JFET
D5, D6, D7, D8, D9, DD	high	low	NPN

Input voltage monitoring

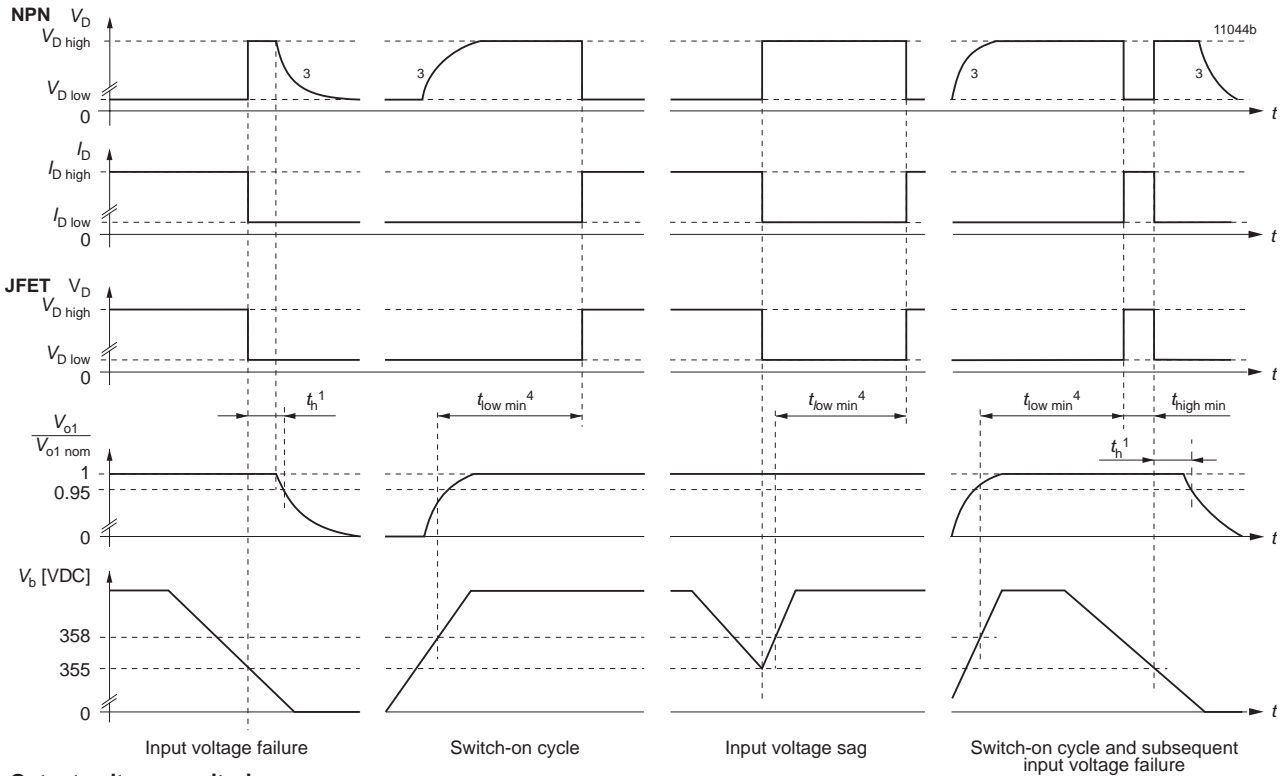

Output voltage monitoring

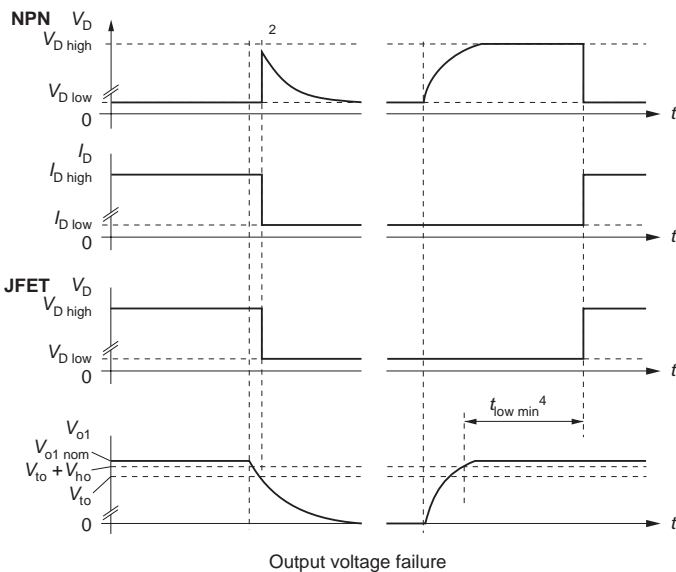

- 1 Hold-up time see: *Electrical Input Data*.
- 2 With output voltage monitoring, hold-up time $t_h = 0$.
- 3 The signal remains high, if the D output is connected to an external source.
- 4 $t_{low\ min} = 100 - 170$ ms, typically 130 ms

Fig. 40
Relationship between V_b , V_{O1} , V_D , $V_{O1}/V_{O1\ nom}$ versus time

V ACFAIL Signal (VME)

Available only for models with $V_o = 5.1\text{ V}$.

This option defines an undervoltage monitoring circuit for the input and main output voltage. It generates the ACFAIL signal (V signal) according to the VME standard.

The low state level of the ACFAIL signal is specified at a sink current of $I_V \leq 48\text{ mA}$ to $V_V \leq 0.6\text{ V}$ (open-collector output of an NPN transistor). The pull-up resistor feeding the open-collector output should be placed on the VME backplane.

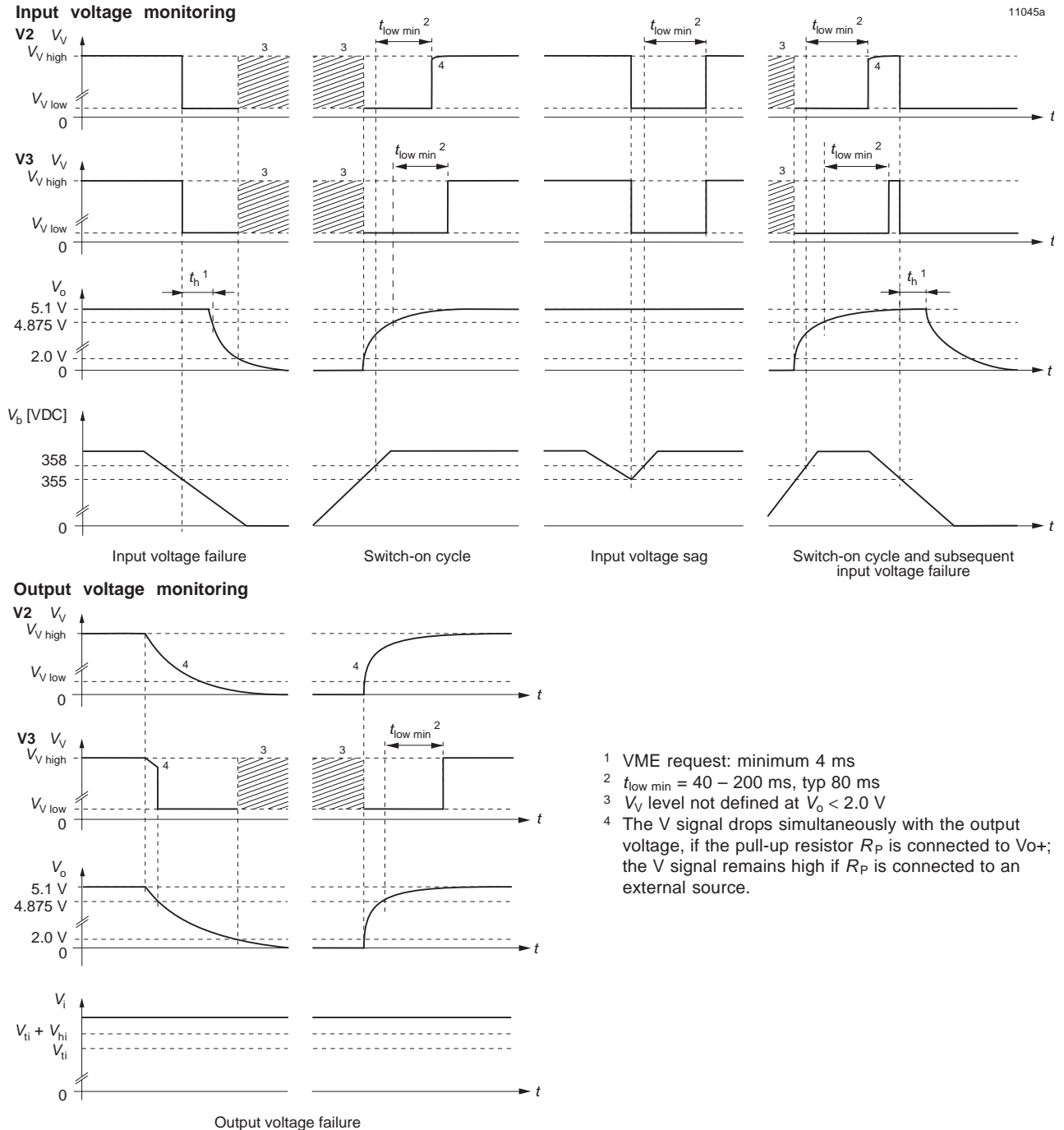

Fig. 41
 V_{cb} , V_o , V_V , I_V , $V_o/V_{o\ nom}$ versus time.

After the ACFAIL signal has gone low, the VME standard requires a hold-up time t_h of at least 4 ms before the 5.1 V output drops at full load to 4.875 V. This hold-up time t_h is provided by the capacitance supporting the boost voltage V_b . See *Hold-up Time*.

Table 25: Undervoltage monitor functions

V output (VME compatible)	Monitoring		Minimum adjustment range of threshold level	
	V_b	V_{o1}	V_{tb}	V_{to}
V2	yes	no	355 VDC ¹	-
V3	yes	yes	355 VDC ¹	0.95 – 0.985 V_{o1} ²

¹ Option V monitors V_b generated by the boost regulator. The trigger level is adjusted in the factory to 355 VDC.

² Fixed value between 95% and 98.5% of V_{o1}

Option V operates independently of the built-in input undervoltage lockout circuit. A logic "low" signal is generated at pin 20, as soon as one of the monitored voltages drops below the preselected threshold level V_t . The return for this signal is S- or V_{o1} -. The V output recovers, when the monitored voltage(s) exceed(s) $V_t + V_h$. The threshold level V_{to} is adjusted in the factory to a customer-specified value.

V-output (V2, V3):

Connector pin V is internally connected to the open collector of an NPN transistor. The emitter is connected to S- or V_{o1} -. $V_V \leq 0.6$ V (logic low) corresponds to a monitored voltage level (V_i and/or V_o) $< V_t$. The current I_V through the open collector should not exceed 50 mA. The NPN output is not protected against external overvoltages. V_V should not exceed 60 V.

Table 26: Status of V output

V_b, V_o status	V output, V_V
V_b or $V_o < V_t$	low, L, $V_V \leq 0.6$ V at $I_V = 50$ mA
V_b and $V_{o1} > V_t + V_h$	high, H, $I_V \leq 25$ μ A at $V_V = 5.1$ V

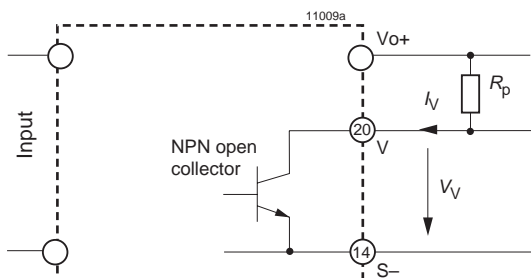

Fig. 42
Output configuration of options V2 and V3

K Connector H15S4

Models with 5.1 V output are fitted with a connector H15S4 (rather than H15S2). This option should be used for new designs and provides compatibility to LK1001 models.

B, B1, B2 Cooling Plate

Where a cooling surface is available, we recommend the use of a cooling plate instead of the standard heat sink. The mounting system should ensure sufficient cooling capacity to guarantee that the maximum case temperature $T_{C \max}$ is not exceeded. The cooling capacity is calculated by:

$$P_{\text{Loss}} = \frac{(100\% - \eta)}{\eta} \cdot V_o \cdot I_o$$

Efficiency η see *Model Selection*

For the dimensions of the cooling plates, see *Mechanical Data*. Option B2 is for customer-specific models with elongated case (for 220 mm DIN-rack depth).

G RoHS

Models with G as last character of the type designation are RoHS-compliant for all six substances.

Accessories

A variety of electrical and mechanical accessories are available including:

- Front panels for 19" DIN-rack: Schroff 16 TE /3U [HZZ00831] and 16 TE /6U [HZZ00832], or Intermas 16 TE /3U [HZZ00731]
- Mating connectors H15, H15S2, and H15S4 with screw, solder, faston, or press-fit terminals.
- Coding clips for connector coding [HZZ00202]
- Connector retention clips (2x) [HZZ01209]
- Connector retention brackets CRB HKMS [HZZ01216]
- DIN-rail mounting assembly DMB-K/S [HZZ0615]

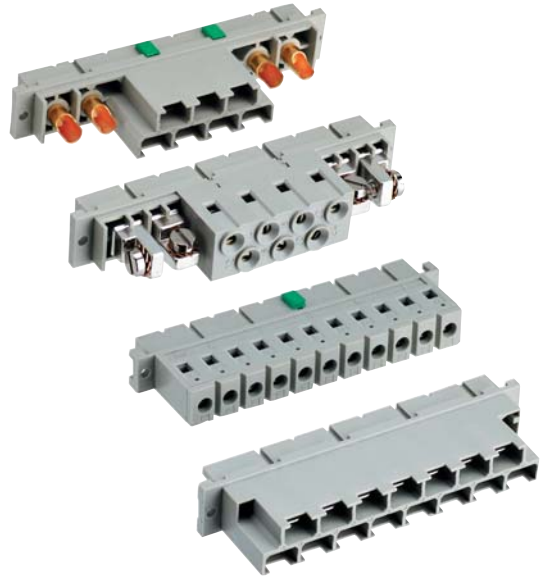

H15, H15S2, and H15S4 female connectors with code key system



Different front panels

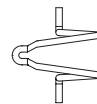

Connector retention clip



DIN-rail mounting assembly DMB-K/S

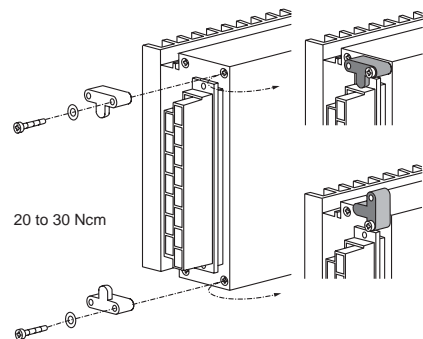

Connector retention brackets CRB HKMS

- Cable connector housing (cable hood) KSG-H15/H15S4 [HZZ00141] as screw version. Also available as retention clip version [HZZ00142], or as a fully metallic housing.
- Wall-mounting plate K02 [HZZ01213] for models with option B1
- Additional external input and output filters
- Different battery sensors [S-KSMH...] for using the converter as a battery charger. Different cell characteristics can be selected; see *Battery Charging/Temperature Sensor*

For additional accessory product information, see the accessory data sheets listed with each product series or individual model listing at www.power-one.com.



Wall-mounting plate
MOUNTINGPLATE-K02



Metallic cable hood providing fire protection

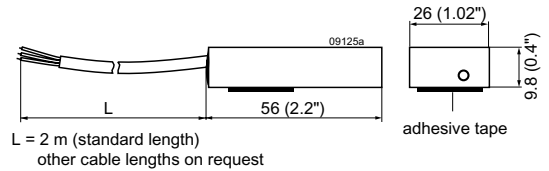

Battery temperature sensor

NUCLEAR AND MEDICAL APPLICATIONS - Power-One products are not designed, intended for use in, or authorized for use as critical components in life support systems, equipment used in hazardous environments, or nuclear control systems without the express written consent of the respective divisional president of Power-One, Inc.

TECHNICAL REVISIONS - The appearance of products, including safety agency certifications pictured on labels, may change depending on the date manufactured. Specifications are subject to change without notice.