



# Design-in guide

Fortimo LED DLM Enhanced Spectrum downlight module system  
Version 1.0

• Fortimo LED DLM Enhanced Spectrum (1800 and 2000)

**PHILIPS**  
sense and simplicity

# Contents

<b>1. Introduction</b>	<b>3</b>	<b>5. Heat sink design and temperature measurements</b>	<b>13</b>
Features and benefits	4	General	13
Applications	4	Test requirements	13
<b>2. LEDs, the heart of the Fortimo LED DLM</b>		Maximum temperature	13
<b>Enhanced Spectrum downlight module</b>	<b>5</b>	Critical measurement points	13
What is a LED?	5	Operation under build-in conditions	13
LED packaging	5	Case temperature and LED module performance	14
Binning	6	Operation in free air	14
LUXEON Rebel LEDs	6	Heat sink design	14
Fortimo LED DLM Enhanced Spectrum		Case temperature and thermal circuit	15
addresses the issue of binning	6	Size of heat sink	16
Color consistency (SDCM)	6	Active and passive cooling	16
Miniaturization	7	Passive cooling	16
<b>3. Fortimo LED DLM Enhanced Spectrum system</b>	<b>7</b>	Air flow	17
Fortimo LED DLM Enhanced Spectrum system	7	Thermal design	17
The basic principles of the Fortimo LED DLM		From the temperature test point T <sub>c</sub> (point 1)	
Enhanced Spectrum system	7	to the side surfaces (point 2)	17
Starting characteristics	7	From the heat sink to ambient (point 3)	17
Luminous flux during start period	8	Thermal model	18
Specification of the system after 100 hours	8	Calculating your heat sink	18
Dimensions of Fortimo LED DLM Enhanced		From the data sheet:	19
Spectrum module and driver	8	For Fortimo LED DLM Enhanced Spectrum	19
Lumen maintenance	9	Now the calculation takes place in three steps:	19
Nomenclature	9	Shape of heat sink	20
About the Fortimo LED DLM Enhanced		Fortimo LED DLM Enhanced Spectrum	
Spectrum module	9	with the two connected heat sinks and three	
Mechanical fixation	9	thermo couples installed	20
About the Fortimo LED DLM driver	9	How to measure T <sub>c</sub>	20
About the Fortimo LED DLM cables	10	SynJet cooling from Nuventix	21
UV and other hazards	10	Nuventix contact information	21
<b>4. Designing a luminaire</b>	<b>11</b>	<b>6. Lighting installations and the environment</b>	<b>22</b>
UL recommendations	11	Electromagnetic compatibility	22
Electrostatic device (ESD) measures	11	Humidity	22
Installation instructions	11	Exposure to direct sunlight	22
Wiring	11	Vibration and shocks	22
Connecting to the mains supply	11	Standards and approvals	22
Connecting to protective ground	11	IP codes, dust and moisture protection	22
Connecting to 12V	12	End-of-life behavior	22
Connecting a Fortimo LED DLM driver to a		Fortimo LED DLM Enhanced Spectrum	
Fortimo LED DLM Enhanced Spectrum module	12	system disposal	22
Cable	12	<b>7. Appendix schematic luminaire with the Fortimo</b>	
Secondary optics	12	<b>LED DLM Enhanced Spectrum system</b>	<b>23</b>

# I. Introduction

Thank you for choosing the Fortimo LED DLM Enhanced Spectrum system. This guide tells you all about this system. If you require any further information or support please consult your Philips sales representative or visit: [www.philips.com/fortimo](http://www.philips.com/fortimo)

The advantages of LEDs have been known for 40 years:

- Long life – low maintenance cost
- Robustness – high reliability
- Saturated colors – maximum visual effect
- Cool beam – no heating of illuminated products
- No UV or IR – wide application possibilities
- Low-voltage operation – more safety, ease of use
- Mercury-free – care for the environment

Rapid improvements in high-power LED technology mean that LEDs can now be used for the first time in 'real' lighting applications, providing improvements over traditional lighting systems.

The use of LEDs has implications for lighting manufacturers in terms of differences in solid-state lighting usage compared with traditional lamps: for example how to design given the constant improvements in specifications; how to provide the necessary heat sinking and how to deal with variations in flux and/or color. The Fortimo LED DLM Enhanced Spectrum system addresses these differences and facilitates easy adoption of LED technology for high lumen packages (1800 lm+). The system is designed for integration in luminaires (system). This design-in guide addresses the relevant issues to support and facilitate the work of specifiers and lighting system designers.

The Fortimo LED DLM Enhanced Spectrum system is, as the name suggests, designed and intended for downlight luminaires. Other applications can be explored by OEMs as long as this creates no design conflicts with the Fortimo LED DLM Enhanced Spectrum system. Please consult us if you wish to deviate from the design rules as described in this application guide.

Reference the Philips website for complementary heat sink or reflector product information.

## Features and benefits

Features	Benefits
2000 lm for 4000 K   1800 lm for 3000 K	Competes with White Son systems available in 3000 K and 4000 K
Optimized spectrum	Enriches appearance
High red green and blue saturation index	Makes colors pop
Less heat and UV	Enabling the luminaire to be installed closer to merchandise
Long lifetime of 50K hours	Resulting in less maintenance cost compared to White Son system
<b>Breakthrough LED L3 energy saving</b>	<b>1st LED product suitable for functional lighting comparable to current benchmark</b>
Patented remote phosphor technology	Driver 15% more efficient than standard LED drivers
Fortimo driver 90% efficiency	
<b>Superior-quality white LED light</b>	<b>An enabler for entry into general lighting</b>
Remote phosphor	Very high (optical) luminaire efficiencies
Optimized light mixing chamber	Perfectly mixed light, consistent color quality and lumen output
Dedicated binning strategy	
<b>Future-proofed, convenient modules</b>	
Fixed form factor	Easy to work with for OEMs
Fixed lumen package	Fewer technical barriers
Easy-to-mount heat sink/optics	Faster time-to-market
Comfortable light	Easy for the end user to experience
No heat or UV	More comfortable, no damage to materials
Instant 100% light	
<b>Long lifetime of 50 K hrs</b>	Low-maintenance
Integrated lifetime-preserving method	More reliable, longer life

## Applications

The Fortimo LED DLM Enhanced Spectrum system is intended for general lighting applications in the professional market for supermarkets and retail.

*\*Not intended for outdoor use*

Neither the Fortimo LED DLM Enhanced Spectrum module nor the LED driver has an IP classification.

If an OEM decides to use the Fortimo LED DLM Enhanced Spectrum system in a luminaire for outdoor application, the OEM is responsible for proper IP protection and approbation of the luminaire.

## 2. LEDs, the heart of the Fortimo LED DLM Enhanced Spectrum downlight module

The development of Light Emitting Diodes (LEDs) is progressing at such a pace that they are rapidly gaining importance for lighting applications. To most people, the term LED still only means the small indicator lights that show whether the TV set is switched on. These tiny light sources barely emit enough light to make themselves visible. However, breakthroughs made in the last few years now allow LEDs to be used for 'real' lighting applications that have traditionally been the domain of incandescent lamps and discharge lamps. Philips Lumileds was the first to bring high power LEDs for lighting applications to the market under the Luxeon trademark. Luxeon emitters are among the highest-performance LEDs in the world, allowing us to offer the brightest solid-state lighting solutions.

### **What is a LED?**

LEDs are solid-state devices, built up from crystalline layers of semiconductor material. The light generation process makes use of the special electronic properties of crystalline semiconductors in a process called injection luminescence. In brief, this means the injection of charged particles by an electric field from one semiconductor layer into another, where they are able to relax to a lower-energy state by emitting visible light. LEDs produce narrow light spectra. The bandwidth remains limited to a few tens of nanometers, and is therefore perceived by the human eye as a single, deeply saturated color. LEDs are now available in all wavelength regions of the visible spectrum; yellow is the only region in which no high-power LED is currently available. White light can be produced by combining LEDs of different colors (for instance red, green and blue), or by applying phosphor coatings on blue or ultraviolet LEDs. Like many other lamps, LEDs cannot be connected directly to the mains. The LEDs have to be operated at a stabilized low voltage, which is provided by an LED driver. However, LEDs do not need ignition and can be switched within milliseconds. LEDs do not generate nearly as much heat as many other lamps, but that does not mean that thermal design is not important. LEDs do produce heat when they operate, and are themselves relatively sensitive to temperature. Thermal considerations are therefore very important aspects of LED lighting system design.

### **LED packaging**

The bare LED die is still a very sensitive and fragile device that must be handled in a clean room environment. Before bringing them outside, they must be packaged. The light flux of conventional LEDs, for example those used as indicator lights on TV sets, is severely limited by the amount of heat generated. In practice, conventional LED packages are limited to about 0.15 W at most, and emit only a few lumens. Their light is too weak to be used for illumination purposes, and they can only be used for luminance applications (i.e. when the light source is intended to be viewed directly). A breakthrough came with a new package design invented by Philips Lumileds, which guides away the heat generated at the diode junction much more efficiently. LEDs based on this package are sold under the trademark Luxeon.

Instead of an epoxy cap, the chip is encapsulated in a silicone gel covered by a polymer lens. Using two different materials for encapsulation and for the primary optics allows better optimization of material properties for heat management and lifetime. The slug is a large metal body that takes up the heat from the chip and provides a low-thermal-resistance route to the outside world. This package design now makes high-power LEDs feasible.

### Binning

The subject of binning should be explained because of its importance in LED system design. As in other semiconductor manufacturing processes, in LED production the number of parameters of the epitaxy process is very large and the process window small (for example, the temperature must be controlled to within  $0.5^{\circ}\text{C}$  ( $<1^{\circ}\text{F}$ ) across the wafer at temperatures of  $\sim 800^{\circ}\text{C}$  ( $1470^{\circ}\text{F}$ ). The difficulty of achieving such a high degree of control means that the properties of the LEDs may vary significantly within single production runs and even on the same wafer. To obtain consistency for a given application, binning (= selection in bins) is mandatory. Binning involves characterization of the LEDs by measurement and subsequently categorizing them into several specific bins. To keep the cost per LED down, LED manufacturers must sell the full production distribution. At the same time they cannot guarantee the availability of all bins at all times. There is a trade-off between logistics and cost price on the one hand, and the application requirements on the other. Setting the specification too tightly will increase the cost price and may lead to logistics problems. System design should therefore try to combine LEDs from different bins intelligently to obtain the required system performance at a reasonable price and with reasonable delivery reliability.



LUXEON Rebel LED

### LUXEON Rebel LEDs

LUXEON Rebel is the smallest surface mountable power LED available today. With the industry's best lumens per package, highest light density (lumens per  $\text{mm}^2$ ), and the highest packing density, LUXEON Rebel is ideal for both space constrained and conventional solid lighting applications. Due to the small mounting surface we have been able to use multiple LUXEON Rebel with the Fortimo products in order to match required high lumen packages of 1800 and up.

### Fortimo LED DLM Enhanced Spectrum system addresses the issue of binning

High-quality LED light is achieved by mixing the light of blue LEDs and red LEDs while applying a special Fortimo phosphor technology remote from the LEDs. A real-time color feedback mechanism ensures that the specific Enhanced Spectrum stays identical over the complete lifetime of the Fortimo LED DLM system. High-quality white light is characterized by a color rendering of  $>70$ , popular CCTs in general lighting applications of 3000 K and 4000 K and a color consistency comparable with conventional HID solutions (five SDCM).

### Color consistency (SDCM)

The target specification of Fortimo LED DLM Enhanced Spectrum systems for color consistency is 5 SDCM @ 0-hours and 6 SDCM @ 10 K hrs. This is a similar specification as for conventional HID lamps. SDCM stands for Standard Deviation of Color Matching and the value 5 refers to the

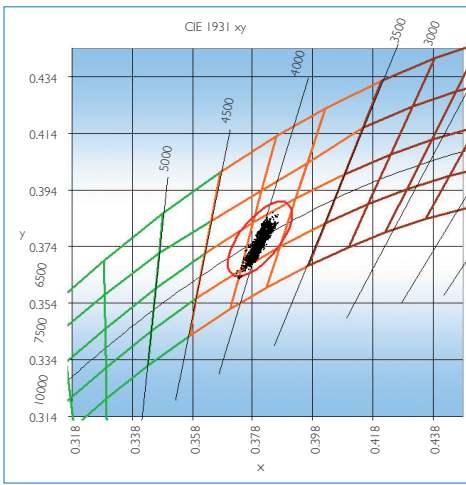

Color consistency (SDCM)

size of an ellipse around the black body locus. Staying within this ellipse results in a consistency of light that ensures that from one luminaire to another no difference can be noticed.

In the visual we have plotted >3000 Fortimo LED DLM systems and you can see they all fit within the 5 SDCM ellipse. This really demonstrates the unique quality of the remote phosphor concept. We also plotted these results in a typical bin distribution sheet of Philips Lumileds. As you can see all Fortimo's fit within 1 color bin! Typically you can buy 6 to 12 bins combinations, not so precise as the 1-bin result of Fortimo.

#### Miniaturization

LEDs are typically much smaller than conventional light sources. Lighting designers and specifiers immediately recognized the fact that LEDs allow dramatically different lighting designs that capitalize on these tiny, unobtrusive light sources. This is understandable, but care must also be taken to deal with the heat produced by power LEDs. Proper heat management places limits on miniaturization.

## 3. Philips Fortimo LED DLM Enhanced Spectrum system



Fortimo LED DLM Enhanced Spectrum

#### Fortimo LED DLM Enhanced Spectrum system

- 929000498703 Fortimo LED DLM1800 50W/Enhanced Spectrum 30UL
- 929000498803 Fortimo LED DLM2000 50W/Enhanced Spectrum 40UL
- 929000478103 Fortimo LED driver 2000 50W/120-277V
- 929000478203 Fortimo LED DLM cable 250mm
- 929000484803 Fortimo LED DLM cable 600mm

#### The basic principles of the Fortimo LED DLM Enhanced Spectrum system

The Fortimo LED DLM system contains three products:

- Fortimo LED DLM Enhanced Spectrum downlight module
- Fortimo LED DLM driver
- Fortimo LED DLM cable (can be ordered separately)

This new system is designed for downlight applications.

#### Starting characteristics

The system can be switched on in milliseconds, which is a general characteristic of LEDs.

### Luminous flux during start period

In contrast to other light sources, LEDs can be switched on at full power instantaneously. The Fortimo LED DLM Enhanced Spectrum system requires an initial burning-in time of 100 hours to reach the listed specifications because of the combination of the LEDs and the remote phosphor used in the modules.

### Specification of the system after 100 hours (August 2009)

	Power	Light output	Efficiency	Comparable LED efficiency	Input voltage	CCT	CRI	Colour consistency initial & 10k hrs
Fixed output systems	W	lm	lm/W	lm/W	V	K	R <sub>a</sub>	SDCM
Fortimo LED DLM1800 50W/Enhanced Spectrum 30UL	50	1800	52	110	120-277	3000	>70	5 6
Fortimo LED DLM2000 50W/Enhanced Spectrum 40UL	50	2000	55	110	120-277	4000	>70	5 6

	Lm main. 35k hrs	Class	Power factor	Total harmonic distortion	Tc life LED module	Tc max LED module	Tc life LED Driver	Burning position
Fixed output systems	%			%	C	C	C	
Fortimo LED DLM1800 50W/Enhanced Spectrum 30UL	70	I	> 0.9	< 20	60	60	60	universal
Fortimo LED DLM2000 50W/Enhanced Spectrum 40UL	70	I	> 0.9	< 20	60	60	60	universal

### Dimensions of Fortimo LED DLM Enhanced Spectrum module and driver

(typical data; ± 0.2 mm)

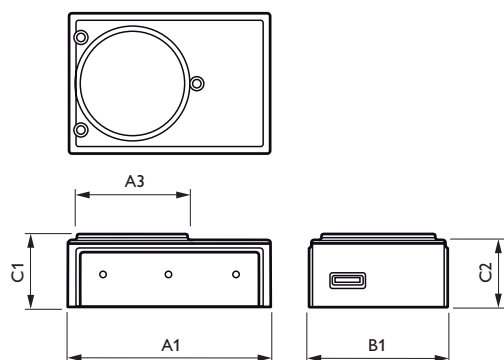

Fortimo LED DLM Enhanced Spectrum module - dimensions

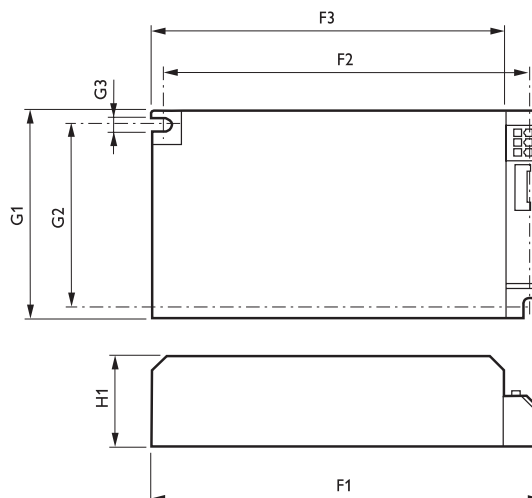

Fortimo LED DLM driver - dimensions

### Lumen maintenance

When used within specification, ( $T_c < 60^\circ\text{C}$ ;  $T_a = 34^\circ\text{C}$ ) lumen maintenance of 70% at 35,000 hours is expected for Fortimo LED DLM Enhanced Spectrum. At 50,000 hours lumen maintenance is 50% (average lifetime specification).

### Nomenclature

The names of the products are defined as follows:

- Fortimo LED DLM Enhanced Spectrum module 1800 50W/30UL (CCT of 3000 K)
- Fortimo LED DLM Enhanced Spectrum module 2000 50W/40UL (CCT of 4000 K)
- Fortimo LED DLM driver 2000 50W/120–277V
- Fortimo LED DLM cable 600 mm

### About the Fortimo LED DLM Enhanced Spectrum module

The LED module consists basically of four main components:

1. PCB with LEDs
2. Mixing chamber
3. Heat sink
4. Diffuser with remote phosphor technology

High-quality white light with high efficiencies is achieved with a plain PCB with LEDs and a remote phosphor film layer. The mixing chamber ensures perfectly mixed light, resulting in uniform colors and good color consistency. The square heat sink facilitates optimal heat transfer in three directions and helps luminaire manufacturers to design their own heat sink system. The heat sink is equipped with screw holes for fixing the heat sink. Besides facilitating high efficiencies, the remote phosphor technology makes it relatively easy to develop virtually any fluorescent color. The function of the diffuser is to shape the light distribution, resulting in a Lambertian beam. The luminaire manufacturer has the freedom to design its own secondary optics. The LED module integrates easy mounting options for secondary optics. The overall dimensions of the LED module, i.e. the combination of heat sink and mixing chamber, are optimized for lumen packages varying from 1800 lumen to 2000 lumen.

### Mechanical fixation

The Fortimo LED DLM Enhanced Spectrum module has screw holes (M4 threaded) at the bottom and sides of the heat sink for affixing the heat sink. As an alternative to screws the Fortimo LED DLM Enhanced Spectrum also has grooves at the side of the module so that a heat sink can be clicked in. 2D or 3D CAD drawings are available upon request.

### About the Fortimo LED DLM driver

The highly efficient Fortimo LED driver is specially designed to operate the Fortimo LED Enhanced Spectrum module. It is designed to operate high-power LEDs with universal main input of (120–277 V). Special features for the fixed output version are:

- High efficiency: 90% at full load (120–277 V)
- $T_{\text{case}} = 60^\circ\text{C}$
- Safety Class I system (protective ground, no SELV system)

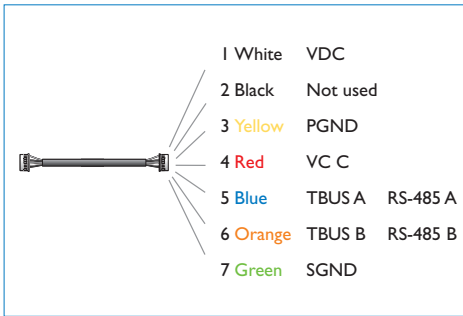

Fortimo LED DLM cable

### About the Fortimo LED DLM cables

For use with the Fortimo LED DLM Enhanced Spectrum system, a specific cable of 250 mm can be ordered separately from the module and driver. A longer 600 mm cable is also available.

### UV and other hazards

PET value: >100 hrs./Klux (zero UV)  
 Damage factor: 0.08 @ 4000 K  
 IR (infrared) radiation: As well as being free of UV radiation, the LED modules are also free of infrared radiation in the beam.

## 4. Designing a luminaire

In this chapter recommendations and values are given to enable optimal luminaire design.

### U.L. recommendations

The general recommendations for luminaire design given by the U.L. 1598, U.L. 8750 and the national safety regulations are also applicable to LED-based luminaires.

### Electrostatic device (ESD) measures

Fortimo LED DLM Enhanced Spectrum systems do not require special ESD measures in a production environment.

### Installation instructions

Fortimo LED DLM Enhanced Spectrum systems are build-in systems for integration into luminaires.

There are interfaces for:

- Cabling between LED module, LED driver and luminaire
- Secondary optics via mounting options in the LED module housing and reflector rim
- Heat sink design

### Wiring

#### Connecting to the mains supply

The mains supply has to be connected to the power supply (L & N can be switched). Because the Fortimo LED DLM driver is Class I, protective ground also needs to be connected. The minimum diameter for the ground cable is 1.5 mm<sup>2</sup>.

#### Connecting to protective ground

Like the Fortimo LED DLM driver, the LED module also needs to be connected to protective ground for reasons of compliance with safety regulations and EMI. The PE symbol  $\oplus$  is shown on the product label to ensure that OEMs take proper measures in their luminaire design. The arrow points to the metal heat sink where cabling needs to be provided.

See also the visuals in the appendix for more detailed explanation.

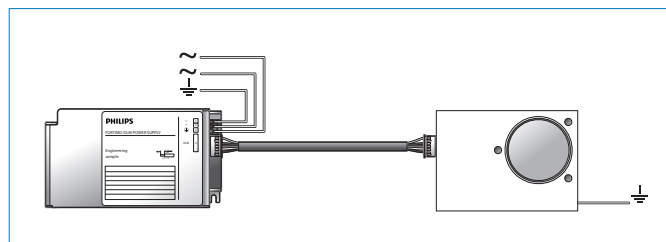

Schematic wiring diagram

### Connecting to 12V

The Fortimo LED DLM Enhanced Spectrum module includes a 12V output that can be used for active cooling options such as Nuventix SynJet (Universal) DLM Coolers or other 12V operating fans.

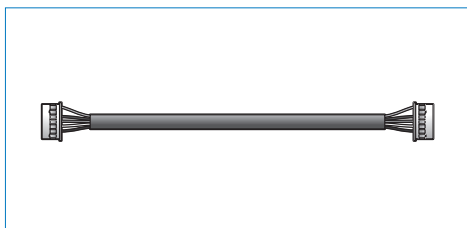

Fortimo LED DLM Enhanced Spectrum cable

### Connecting a Fortimo LED DLM driver to a Fortimo LED DLM Enhanced Spectrum module

Specific cables have been developed to connect the Fortimo LED DLM Enhanced Spectrum module and the Fortimo LED DLM driver. 250 or 600 mm cables with a wire diameter of AWG24 can be ordered separately.

**WARNING:** the LED DLM cable should never be connected or disconnected from driver or module while the driver is powered. This can cause damage to both driver and LED module.

### Cable

We advise using the dedicated Fortimo LED DLM cable. However if an OEM prefers to have a cable with a different length, the OEM is responsible for its sourcing. The cable specification should meet UL requirements. However, UL approval of the Fortimo LED DLM Enhanced Spectrum module and Fortimo LED DLM driver is based on a reference luminaire with the standard cable length of 600 mm. In any case, any luminaire design needs its own approval, organized by the responsible OEM, irrespective of the length of cable used.

If an OEM prefers to have a cable with a different length it can use the following cable/connector specifications:

JST connector at cable to LED driver:	housing: JST PAP-07V-S contact: JST SPHD-001 T-P0.5
JST connector at cable to LED module:	housing: JST-PHR-7 contact: JST SPH-002T-P0.5S

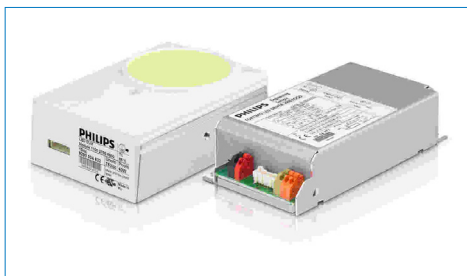

Fortimo LED DLM 1800 & 2000 Enhanced Spectrum

### Secondary optics

The Fortimo LED DLM Enhanced Spectrum module generates a Lambertian beam shape which is a pragmatic starting point for secondary optic design by OEMs. Ray-set files are available upon request. The secondary optic design should not cover the exit aperture.

It is not recommended to put a secondary optics within 70 mm of the Fortimo LED DLM Enhanced Spectrum light exit window. When the product is installed according to the guidelines, temperature of the light exit window will be below 80° C. When the customer decides to place a secondary optics within 70 mm of the light exit window, the customer should take care that the temperature of the material will not exceed 80° C. The temperature of the light exit window can be measured with Infrared temperature sensing technique.

There are mounting options on top of the Fortimo LED DLM Enhanced Spectrum module (rim of diffuser and three mounting holes) for positioning of secondary optics.

# 5. Heat sink design and temperature measurements

## General

For optimum performance the Fortimo LED DLM system must operate within specified temperature limits.

## Test requirements

The Fortimo LED DLM Enhanced Spectrum systems have no specific measurement for minimum ambient temperature, which may be as low as  $-20^{\circ}\text{C}$ . This minimum limit is determined by the Fortimo LED driver. Temperature measurements should only be performed when the luminaire is thermally stable, which may take 0.5 to 2 hours depending on the thermal capacity of the luminaire. For all measurements such as temperature, luminous flux and power, a stabilization period of at least half an hour must be allowed before any reliable data can be obtained. Measurements must be performed by means of thermocouples that are firmly glued to the surface.

## Maximum temperature

Because LEDs are temperature-sensitive, LED modules require a different approach with respect to the maximum permissible component temperature. This is different to most other types of light sources.

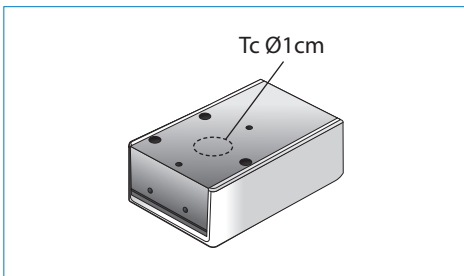

Tc measurement point of Fortimo LED DLM Enhanced Spectrum module

## Critical measurement points

For LEDs the junction temperature is the critical factor for operation. Since there is a direct relation between the case temperature and the LED junction temperature it is sufficient to measure the aluminum casing of the LED module at its critical point. The critical point is on the back surface of the LED module (see picture to the left). If the case temperature ( $T_c$ ) at the critical measurement point is too high (exceeding the recommended maximum temperature), the performance of the LEDs will be adversely affected, for example in terms of light output, lifetime or lumen maintenance.

## Operation under build-in conditions

The heat produced by the LED driver and LED module in the luminaire (or similar housing) must be dissipated to the surroundings. If a luminaire is physically insulated by a ceiling, wall or insulation blanket, the heat produced cannot easily be dissipated. This will result in heating of the LED driver and the LED module in the luminaire, which in turn can have an adverse effect on system performance and lifetime. For optimum performance and lifetime it is important that:

- Air can flow freely around the luminaire; and
- Airflow through the luminaire, around the modules, has a positive effect on temperature control and hence on performance and lifetime.

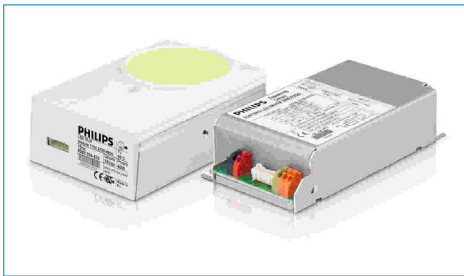

Fortimo LED DLM1800 & 2000 Enhanced Spectrum

The above-mentioned engagement of the thermal circuit at  $T_c = 60^\circ\text{C}$  is applicable to both the 1800 and the 2000 lumen versions. The performances of light output, light maintenance and lifetime are related to different  $T_c$  values like

- $T_c = 60^\circ\text{C}$  for Fortimo LED DLM1800 & DLM2000 Enhanced Spectrum

This is based on the assumption that the same heat sink design is used for both versions, where obviously the 2000 lumen version is the most critical one.

### Case temperature and LED module performance

The Fortimo LED DLM Enhanced Spectrum module is designed for a case temperature of  $60^\circ\text{C} / 113^\circ\text{F}$ . Due to the light feedback system, the light output is kept constant.

### Operation in free air

The Fortimo LED DLM Enhanced Spectrum system is not designed for operation in free air. The Fortimo LED DLM Enhanced Spectrum system is a build-in concept for integration into luminaires.

### Heat sink design

To ensure that housing temperatures do not exceed the specified maximum values, a luminaire can act as an additional heat sink. The applicable heat transport mechanisms are conduction via the heat sink and convection and thermal radiation to the surroundings. The objective of this chapter is not to indicate exactly how to calculate a heat sink, but to give some guidelines on how to improve its performance. Although a heat sink can have many (complex) shapes, the following discussion is based on a disk type of heat sink. The results for square plates, etc., are more or less the same provided the surface areas are equal. The type of material used has a relatively large influence on the final result. For example, a comparison of the thermal conductivity ( $k$ ) of copper with that of corrosion-resistant steel (see table on page 15) shows that a substantially smaller heat sink can be made with copper. The best material for heat sinks is (soft) aluminum.

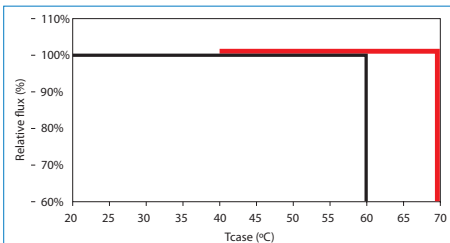

Temperatures Fortimo LED DLM2000 Enhanced Spectrum

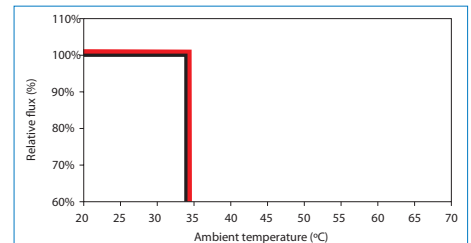
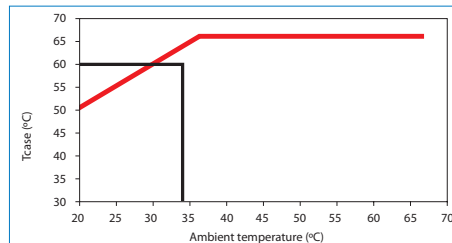

### Case temperature and thermal circuit

To ensure the performance of the Fortimo LED DLM Enhanced Spectrum system we have defined a  $T_c$  at the back surface of the LED module of  $60^\circ\text{C}$ . At that case temperature the junction temperature of the LEDs is assured and the indicated performances (lifetime, light output, lumen maintenance) can be guaranteed. Above a  $T_c$  of  $60^\circ\text{C}$ , a thermal circuit will be engaged. This circuit will dim the LED module until the  $T_c$  of  $60^\circ\text{C}$  is reached again. The graphs on page 14 display the typical case temperature and relative flux as a function of ambient temperature, for a calculated heat sink performance of  $1\text{ K/W}$ . The Fortimo LED DLM driver has a  $T_c$  of  $60^\circ\text{C}$ .

The thickness ( $d$ ) of the heat sink disk is also of major importance. Assuming the use of different heat sinks of the same diameter but made from different materials, the same effect in terms of temperature difference will be achieved if the product of thermal conductivity ( $k$ ) and disk thickness ( $d$ ) is constant. This means the same result is obtained with a disk of  $1\text{ mm}$  copper,  $2\text{ mm}$  aluminum,  $4\text{ mm}$  brass,  $8\text{ mm}$  steel or  $26\text{ mm}$  corrosion-resistant steel. Increasing the diameter, and thereby also the surface area, of the heat sink disk also leads to an improvement, but the effect is smaller for larger diameters and depends on the thermal conductivity ( $k$ ) of the material and the thickness ( $d$ ).

Thermal radiation can also form a substantial part of the total heat transfer, and is of the same order as for convection. This depends strongly on the emission coefficient (see below) of the surface, which lies between 0 and 1. For example, a polished aluminum surface has a very low emission coefficient, while that of a painted surface is very high.

Material	W/mK
Copper	400
Aluminum	200
Brass	100
Steel	50
Corrosion-resistant steel	15

Thermal conductivity

Material	W/mK	Emission coefficient
Aluminium	new/polished	0.04 - 0.06
	oxidized	0.2 - 0.3
	anodized	0.8
Steel	painted	0.8 - 0.95
	new/polished	0.03 - 0.07
	heavily oxidized	0.7 - 0.8

Emission coefficients

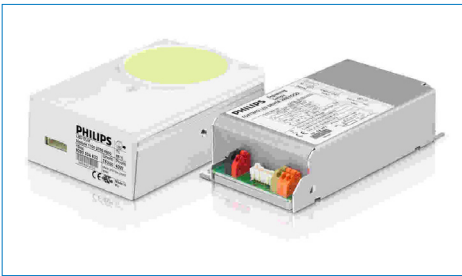

Fortimo LED DLM1800 & 2000 Enhanced Spectrum

### Size of heat sink

The Fortimo LED DLM Enhanced Spectrum module will produce 25 watts of heat during operation that needs to be taken away from the module. The aluminum surface area on the sides and rear of the module serve as the contact area for the external heat sink. The module's aluminum surface area transports the heat away from the module and is connected to the external heat sink, with either the use of the pre-made screw holes or the side grooves.

The performance (lifetime) of the module depends heavily on the thermal management. Therefore the temperature of the test point ( $T_c$ ) is important. During the thermal design process, the aim is to keep the  $T_c$  temperature below the stated maximum ( $60^\circ\text{C}$ ). Although the Fortimo LED DLM Enhanced Spectrum module will not fail due to a higher temperature, the effect of insufficient cooling will mean that the light output of the LEDs is automatically dimmed. So the better the thermal management (low  $T_c$  of the LED module), the better the performance of the luminaire (lifetime). This design choice provides a differentiation opportunity for luminaire manufacturers.

If miniaturization is required, then active cooling systems may be used which will substantially reduce the volume of the heat sink.

### Active and passive cooling

There are two thermal cooling options, passive and active cooling.

**Passive cooling** systems are made so that hot air moves upwards, and an airflow is created along the surfaces. This is called natural convection.

**Active cooling** systems have airflow that is forced with a fan or SynJet, which enhances the thermal capacity of the heat sink. As a result, a smaller heat sink can be used and orientation of the heat sink is no issue anymore. Negative aspects of active cooling is the possibility of additional noise caused by a fan, as well as incremental energy consumption. Note that the OEM needs to engineer a cooling solution that matches the entire system's lifetime and intended application.

There are many standard heat sinks available which are relatively cost effective. When comparing active cooling, the form factor of the total system is approximately two times larger.

### Passive cooling

There are two passive thermal solutions.

As shown in Figure A, the solution with the heat sinks connected to the sides of the module has the advantage of lower height, but a larger diameter. The disadvantage is an extra thermal resistance path from test point  $T_c$  (in the center of the rear surface) to the sides where the heat sinks are connected.

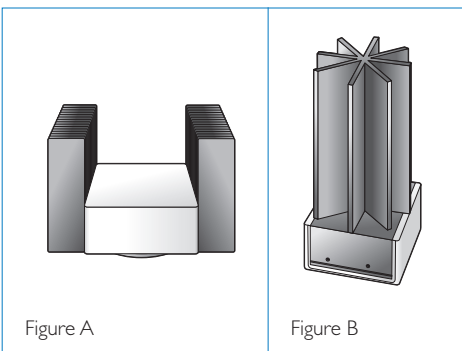

Passive solution

Fortimo LED DLM Enhanced Spectrum

As shown on the right sides of Figure A and B (page 16), the heat sink is connected to the backside of module. This configuration provides no extra thermal resistance, though to achieve this same cooling capacity, extra height is required.

### Air flow

Before starting with any calculation, an important point to consider is the airflow.

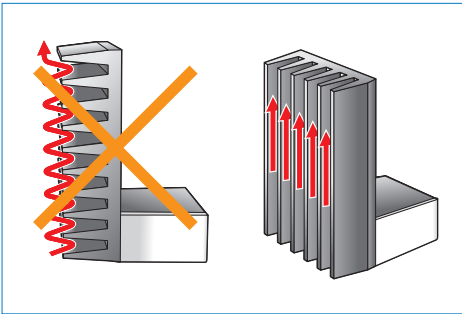

In general, hot air is moving upwards with relatively low speed. The form and position of the heat sink is influencing the airflow. In the picture on the left, the the fins are perpendicular to the airflow which reduces the efficiency of the heat sink. This situation should be avoided.

A better way to position the fins is indicated in the picture on the right, where the fins are parallel to the airflow direction. Closing the top of the profile will reduce the effectively of the heat sink as well, and should be avoided during design and installation.

### Thermal design

There are two main thermal paths to consider — from the temperature test point to the side surfaces and from the heat sink to the ambient temperature (warming up and dynamic behavior are not discussed here, as a static situation is normally found in lighting applications).

#### From the temperature test point $T_c$ (point 1) to the side surfaces (point 2)

- This is already measured by Philips and is 0.2 K/W. Please note that if you attach the heat sink directly to the back of the module, the 0.2 K/W should be considered.

#### From the heat sink to ambient (point 3)

The thermal resistance of a heat sink is normally given in a data sheet, but it is based on a few assumptions:

- A certain thermal power has to be applied, as the efficiency of the heat sink is lower at low energy levels
- The temperature of the backside of the heat sink is homogeneous
- An air flow can freely flow over the surfaces

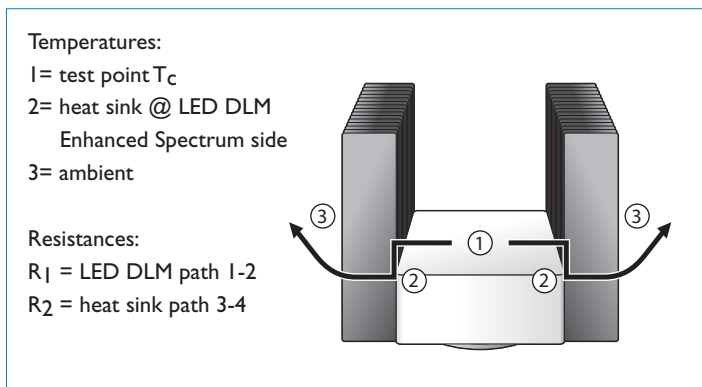

Thermal path basic solutions

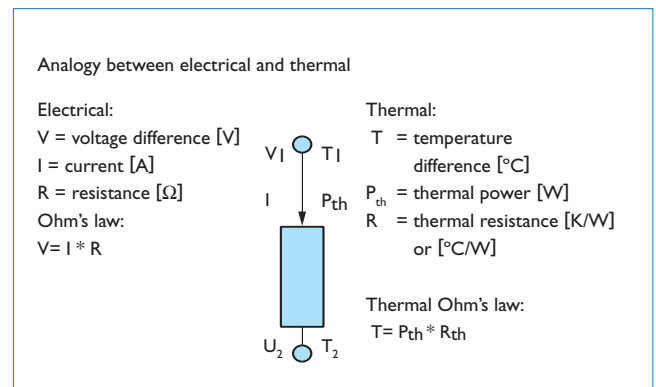

Electrical and thermal analogy

### Thermal model

Standard STATIC thermal situations can be modeled with so-called thermal resistances. These resistances behave like electrical resistors. Below the analogy between electrical and thermal resistors is explained. Where on the left the electrical units are mentioned, on the right the thermal equivalent is set.

With a known voltage difference at a certain current it is possible to calculate an electrical resistor with Ohm's law. The same is possible with a thermal resistor. If the temperature difference is known and the thermal power, the thermal resistance can be calculated with thermal Ohm's law.

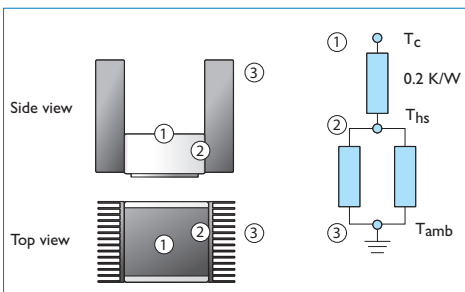

Thermal resistance of Fortimo LED DLM Enhanced Spectrum Module

In the left figures you see the two most important thermal resistances.

- From test point T<sub>c</sub> to side surface of the Fortimo LED DLM Enhanced Spectrum module, where the heat sinks are connected.
- From side surface of Fortimo LED DLM Enhanced Spectrum module to ambient. As we have connected two heat sinks, both will have a similar thermal resistance in parallel.
- In the specification the maximum T<sub>c</sub> is given, in case of a Fortimo LED DLM Enhanced Spectrum system this is 60° C.

### Calculating your heat sink

We start with 3 thermal calculation formulas:

- Formula 1 (f1) the relation between temperature difference, thermal power and thermal resistance. With this formula the needed thermal resistance can be calculated when the thermal power and temperature difference are known.
- Formula 2 (f2) shows how to calculate the replacement of two parallel resistors, with one equivalent.
- Formula 3 (f3) shows the replacement equivalent of 2 resistors in series, simple add the values.

**Formulas:**

Thermal:  $\Delta T = R_{th} \times P_{th}$  f1

Parallel:  $R_{th-R1+R2} = \frac{1}{\frac{1}{R_1} + \frac{1}{R_2}}$  f2

Series:  $R_{tot} = R_1 + R_2$  f3

**Available information:**

T<sub>c-max</sub> = 60° C

P<sub>th-</sub> = 25 W

R<sub>th-Tc-to-hs</sub> = 0.2 K/W

T<sub>ambient-max</sub> = 34° C

**To be calculated:**

R<sub>th</sub> both heat sinks

Thermal resistance of heat sink

**1. Calculation of total maximum thermal resistance: (f1)**

$$\Delta T_{\text{ambient}-T_c} = 60 - 34 = 26 \text{ }^\circ\text{C}$$

$$R_{\text{th } T_c - \text{ambient}} = (T_{\text{ambient}} - T_c) / P_{\text{th}} = 26 / 25 = 1.04 \text{ K/W}$$

**2. Calculation of thermal resistance two heat sinks: (f3)**

$$R_{\text{th } \text{hs} - \text{ambient}} = R_{\text{th } T_c - \text{hs}} + R_{\text{th } \text{hs} - \text{ambient}}$$

$$R_{\text{th } \text{hs} - \text{ambient}} = 1.04 - 0.2 = 0.84 \text{ K/W}$$

**3. Calculation of thermal resistance per identical heat sink: (f2)**

$$R_1 = R_2 \text{ and } R_{\text{tot-hs-amb}} = 1 / (1/R_1 + 1/R_2)$$

$$R_{\text{tot}} = 1 / (2/R_1) = R_1/2 \text{ } \Leftrightarrow \text{ } R_1 = 2R_{\text{tot}}$$

$$R_1 = R_{\text{th single heat sink}} = 2 \cdot 0.84 = 1.68 \text{ K/W}$$

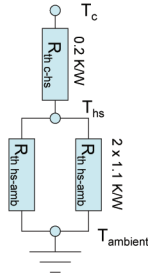

Thermal resistance of heat sink

Next, we gather all available information, as can be found in the data sheet, application details and design choices.

**From the data sheet:**

Maximum test point temperature:	$T_{c-\text{max}} = 60^\circ \text{ C}$
Thermal power Fortimo LED DLM2000 Enhanced Spectrum:	$P_{\text{th}} = 25 \text{ W}$
Thermal resistance from $T_c$ to side surface:	$R_{\text{th}-T_c\text{-to-side-surface}} = 0.2 \text{ K/W}$
Maximum temperature in application:	$T_{\text{ambient-max}} = 34^\circ \text{ C}$ chosen in this case.

In this case we install the product below ceiling, which is the ambient temperature of the product.

The maximum temperature differs per application and can be lower or higher, than the now chosen  $34^\circ \text{ C}$ .

Below we calculate the needed thermal resistance of the heat sink, such that in worst case situations, the maximum temperature of the test point  $T_c$ , is below its maximum.

**For Fortimo LED DLM Enhanced Spectrum:**

Maximum test point temperature:	$T_{c\text{max}} = 60^\circ \text{ C}$
Thermal power Fortimo LED DLM Enhanced Spectrum:	$P_{\text{th}}: 25 \text{ W}$
Thermal resistance from $T_c$ to side surface:	$R_{\text{th}-T_c\text{-to-side-surface}} = 0.2 \text{ K/W}$
$T_{\text{ambient-max}}$ :	$34^\circ \text{ C}$

**Now the calculation takes place in three steps:**

- Calculation of the total thermal resistance :  $R_{\text{th-from-}T_c\text{-to-ambient}}$  with formula f1. This results in 1.04 K/W.
- Calculation of the thermal resistance of both heat sinks with formula f3. This results in subtracting 0.2 from the total value of 1.04 K/W, which is 0.84 K/W.
- Thermal resistance of a single heat sink with formula f2. We assume that both heat sinks are identical, and results in the equation  $R_1 = R_2$ . Using this together with formula f2 the end result shows that the thermal resistance of a single heat sink is two times the total thermal resistance of both heat sinks. This results in 1.68 K/W.

- Example of standard heat sink:
- Needed 1.68K/W
  - Heat sink example : Marston 94DN
  - Length @ 1.68 K/W = <75 mm (red line)
  - Width= 123 mm, height= 40 mm, #fins= 13

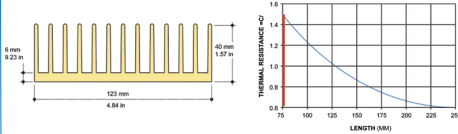

Thermal resistance of heat sink

Now we know the thermal resistance of the needed heat sink. This heat sink dimension is such that at maximum power and maximum ambient temperature, the temperature of the test point  $T_c$  is at or below its maximum of  $60^\circ\text{C}$ . This is the worst case situation, which means that normally the test point temperature  $T_c$  is lower. This assures lifetime and light output will be according to specifications.

### Shape of heat sink

When looking into catalogs of heat sink suppliers, the shape is determining the thermal resistance of the heat sink. In this case the length is a design parameter.

As shown in the graph, a heat sink of 1.68 K/W with a length of slightly below 75 mm is required.

There are many variations in fin number, length of fins, length of heat sink and so on. With special thermal design software, a tailored solution can be found as well.

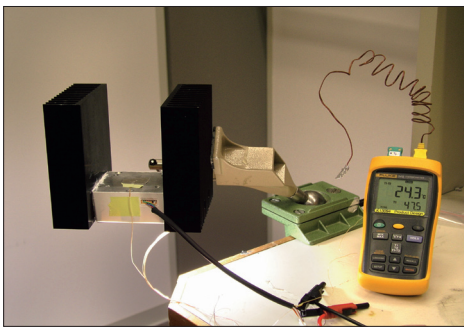

With the use of a standard thermo couple all important temperatures can be measured and compared to theoretical values.

**On the left you see the standard set-up for thermal testing of the Fortimo LED DLM Enhanced Spectrum system which includes two connected heat sinks and three thermocouples.**

Key thermocouple test points are:

- At test point  $T_c$
- At the heat sink interface of the Fortimo LED DLM Enhanced Spectrum module
- At the ambient temperature in situation

With this simple set-up, all important values can be measured and compared to the theoretical values. It's important to assure good thermal contact between Fortimo LED DLM Enhanced Spectrum module and the heat sinks. We recommend using thermal pads or thermal paste. Furthermore, it is very important that there is no moving air in the room. This will influence the measurement heavily.

### How to measure $T_c$

In case you have no direct or easy access to connect a thermo couple to the defined  $T_c$  point, we recommend connecting the thermo couple to one of the sides of the Fortimo LED DLM Enhanced Spectrum module. The heat sink that is integrated in the Fortimo LED DLM Enhanced Spectrum module ensures that temperature difference for  $T_c$  point to both sides is minimal. In the visual on the left, you see this difference is approximately 8 degrees with a Fortimo LED DLM Enhanced Spectrum module of 2000 lumens. If a heat sink is connected to the back of the module, this temperature difference will reduce to 4 degrees.

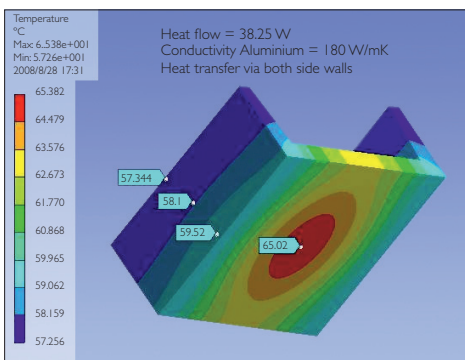



### SynJet cooling from Nuventix

Nuventix has developed a cooling solution utilizing SynJet technology that offers silent operation, long life and robust cooling for Fortimo LED DLM Enhanced Spectrum systems. Its' small size allows it to be used in tight spaces. SynJet cooling allows for universal mounting, permitting great flexibility in installation. The unit is designed for use with 1800 and 2000 lumen Fortimo LED Enhanced Spectrum modules, providing long-term thermal solutions for LED lighting.

Nuventix offers these standard versions:

- SynJet DLM Cooler with heat sink (round)
- SynJet Universal DLM Cooler with heat sink (square)

Design and assembly guides are available for both products by request.



### Nuventix contact information

For full specification and application assistance, please contact Nuventix directly:

Jeff Kelley, VP Sales, Americas

E-mail: [jkelly@nuventix.com](mailto:jkelly@nuventix.com)

512. 382. 8116 or 512. 422. 4391

4635 Boston Lane

Austin, TX 78735

[www.nuventix.com](http://www.nuventix.com)

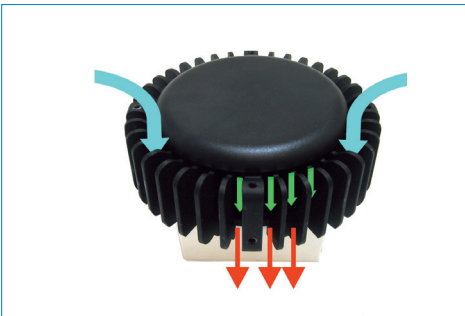

Below are some additional references for other fan suppliers:

**Emb Papst**, website: <http://www.ebmpapst.com/de/>

Emb Papst is a high-end, German-based fan supplier. They cover a broad application range (including automotive applications) and have a lot of experience in fan applications for harsh environments.

**Sunon**, website: <http://www.sunon.com/index.htm>

Sunon is a large Taiwan-based fan supplier, mainly active in electronics cooling. Their Maglev technology uses a magnetic field to stabilize the fan, resulting in long life and low noise.

Further we would like to mention two Taiwanese suppliers of cooling assemblies (combinations of fan + heat sink):

AVC: website: <http://www.avc.com.tw/>

CoolerMaster: website: <http://www.cooler-master.com/>

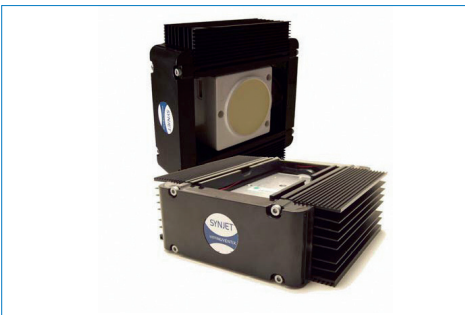

Both suppliers are active in PC cooling solutions and are starting a business for LED solutions as well. Please check the Fortimo webpage ([www.philips.com/fortimo](http://www.philips.com/fortimo)) for the latest info on our complementary partners.

## 6. Lighting installations and the environment

### Electromagnetic compatibility

Electromagnetic compatibility, EMC, is the ability of a device or system to operate satisfactorily in its electromagnetic environment without causing unacceptable interference in practical situations. Philips Fortimo LED DLM systems enable a FFC Part 15 Class A Luminaire.

### Humidity

Fortimo LED DLM modules and LED drivers have no IP classification. The OEM is responsible for proper IP classification and approbation of the luminaire.

### Exposure to direct sunlight

Exposure to direct sunlight during operation may have severe temperature or UV effects. Where this situation is likely, extensive temperature testing is recommended. The Fortimo LED DLM systems are a build-in system (except independent versions), so this is expected to be negligible.

### Vibration and shocks

Shock resistance: 50 g @ 6 ms semi-sinusoidal

Vibration resistance: Sweep 50–150 Hz, one hour at resonance frequency (all 3 axes) without failure

### Standards and approvals

Philips Fortimo LED DLM systems comply with the following international rules and regulations:

Electrical Classification: UL Class I

Approvals: UL 8750, CSA C22.2 No. 250.0

### IP codes, dust and moisture protection

Philips Fortimo LED DLM Enhanced Spectrum systems are build-in systems (except independent versions) and have no IP rating.

### End-of-life behavior

Unlike typical conventional light sources, LEDs are not subject to sudden failure or burnout. There is no time at which the light source will cease to function. Instead, the performance of LEDs shows gradual degradation over time. When used according to specification, Fortimo LED DLM Enhanced Spectrum modules are predicted to deliver an average of 70% of their initial intensity after 35,000 hours of operation. The life of the system is therefore more dependent on the other electronic system components and soldering methods.

The LEDs in the Fortimo LED DLM Enhanced Spectrum module are connected in series. If one LED fails, this may be due to an internal short-circuit (character of blue LEDs). In this case it will still conduct current, so that the other LEDs will still operate.

### Fortimo LED DLM Enhanced Spectrum system disposal

At the end of their (economic) lifetime, appropriate disposal of the Fortimo LED DLM Enhanced Spectrum system or its components is recommended. The modules are basically normal pieces of electronic equipment containing components that at present are not considered to be harmful to the environment, or which can be disposed of with normal care. It is therefore recommended to dispose of these parts as normal electronic waste, according to local regulations.

# 7. Appendix

## Schematic luminaire with the Fortimo LED DLM Enhanced Spectrum system

Fortimo LED DLM Enhanced Spectrum systems have been designed to build the driver inside the luminaire. Added value opportunities for OEM are optic, heat sink and luminaire design (dotted lines).

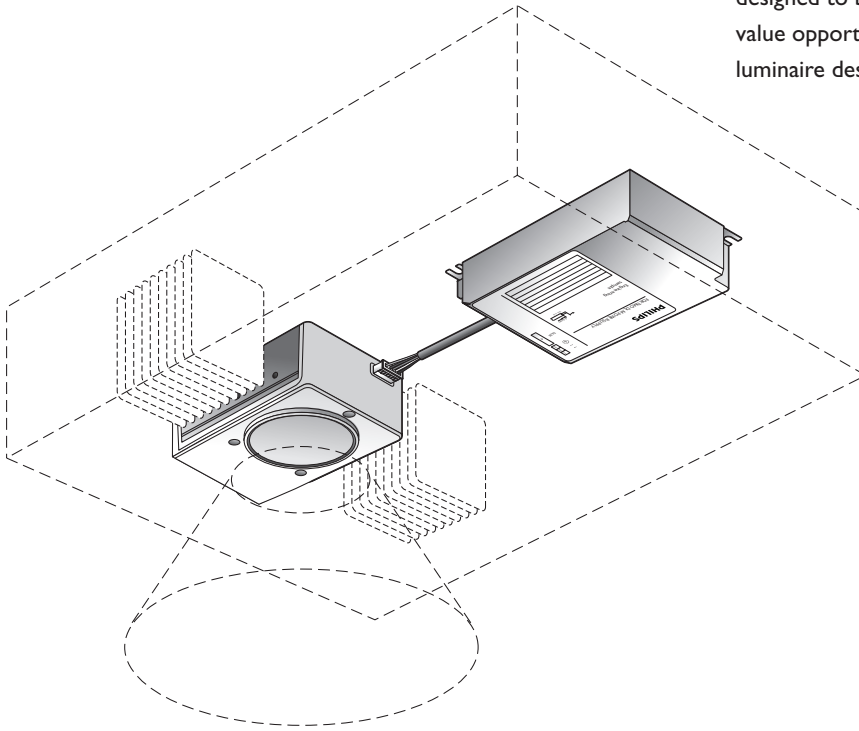

Fortimo LED DLM Enhanced Spectrum systems are Class I systems requiring proper protective earth wiring. It's important that both the driver as well as the LED module are connected to protective earth. In the drawing below you see how to wire the Fortimo LED DLM Enhanced Spectrum system components properly.

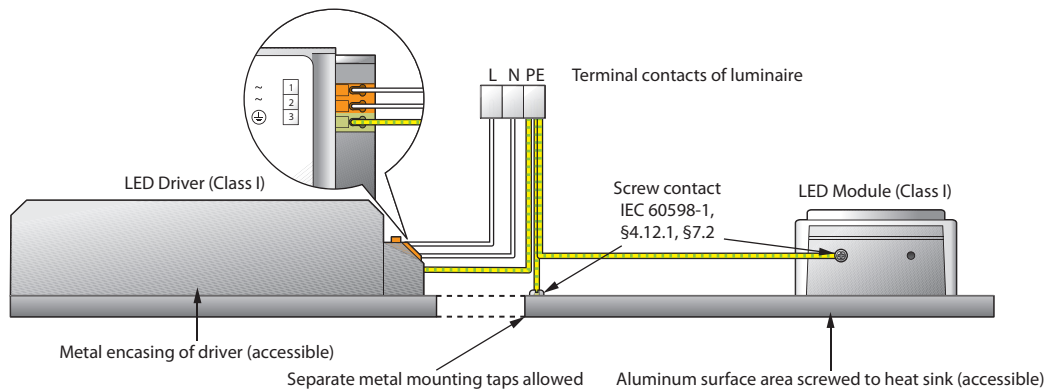



©2010 Philips Lighting Electronics N.A.  
All rights reserved.

Form No. LE-6220-B

Philips Lighting Electronics N.A.  
10275 West Higgins Road  
Rosemont, IL 60018  
Tel: 800-322-2086 Fax: 888-423-1882  
Customer Support/Technical Service: 800-372-3331  
OEM Support: 866-915-5886  
[www.philips.com/fortimo](http://www.philips.com/fortimo)