

Six-Element SMD Photodiode Array

OPR2100, OPR2100T, OPR2101



Features:

- Six-PIN photodiode array
- High-temperature chip carrier
- Closely matched responsivity between elements
- Choice of regular or miniature package style
- Easily mountable in any configuration
- Suitable for harsh industrial operating conditions

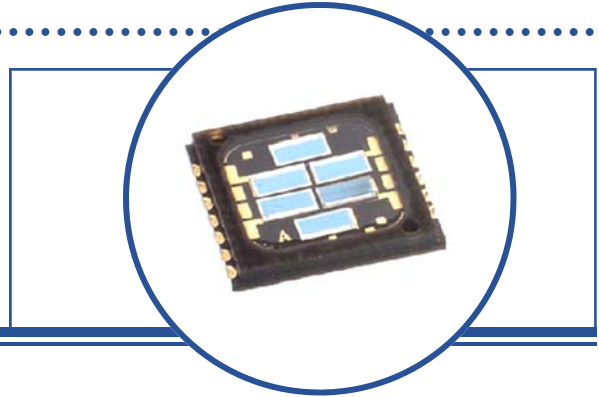

Description:

Each **OPR2100** and **OPR2101** device is a six-element photodiode that is designed to meet the needs of motor encoder applications. Designed specifically for *industrial* encoder applications, the miniature-sized **OPR2101** features a high temperature SMD chip carrier, a temperature range and a low leakage current that can withstand extreme operating conditions.

Both devices have an opaque chip carrier that encloses six individual chips, which are mounted on isolated cathode contacts to allow external connection in any desired configuration. The opaque polyimide package shields the photodiodes from stray light and can withstand multiple exposures to the most demanding soldering conditions, while the gold-plated wraparound solder pads provide exceptional storage and wetting characteristics.

See Application Bulletin 237 for handling instructions.

Applications:

- Motor encoder applications
- Industrial encoder applications

Ordering Information						
Part Number	Sensor	# of Elements	Responsivity (mA/mW) Min	Reverse Voltage Breakdown	Active Area mm ²	Packaging
OPR2100	Photodiode Array	6	0.45	50	3.45	Tube
OPR2100T	Photodiode Array	6	0.45	50	3.45	Tape & Reel
OPR2101	Miniature Photodiode Array	6	0.45	50	0.84	Tube

OPR2100

Pin #	Description
1	Cathode A
2	Cathode B
3	Anode B
4	Anode C
5	Cathode C
6	Cathode D
7	Anode D
8	Cathode E
9	Anode E
10	Anode F
11	Cathode F
12	Anode A

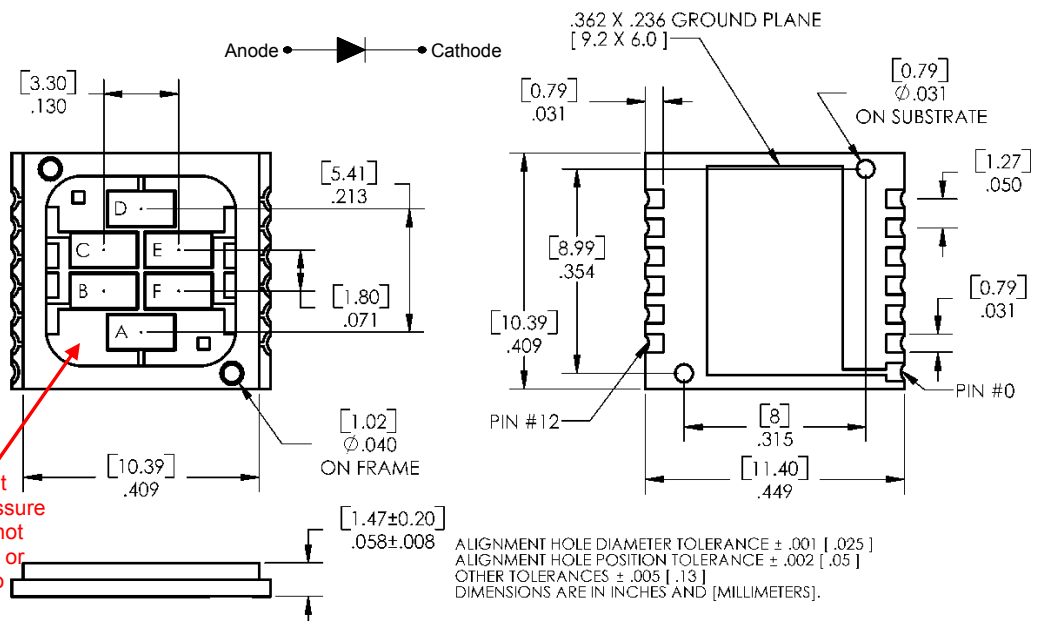

ALIGNMENT HOLE DIAMETER TOLERANCE ± .001 [.025]
ALIGNMENT HOLE POSITION TOLERANCE ± .002 [.05]
OTHER TOLERANCES ± .005 [.13]
DIMENSIONS ARE IN INCHES AND [MILLIMETERS].



RoHS

OPTEK reserves the right to make changes at any time in order to improve design and to supply the best product possible.

Six-Element SMD Photodiode Array

OPR2100, OPR2100T, OPR2101

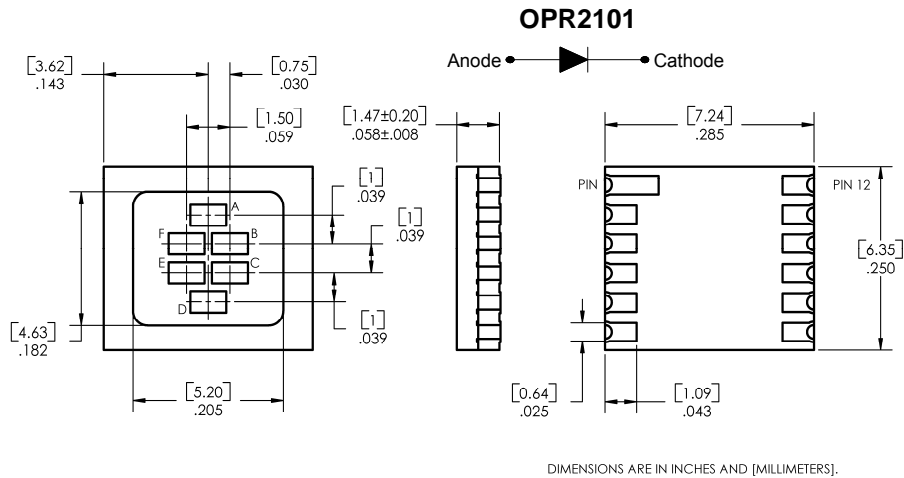

Pin #	Description
1	Cathode A
2	Cathode B
3	Anode B
4	Anode C
5	Cathode C
6	Cathode D
7	Anode D
8	Cathode E
9	Anode E
10	Anode F
11	Cathode F
12	Anode A

Absolute Maximum Ratings ($T_A = 25^\circ\text{C}$ unless otherwise noted)

Storage and Operating Temperature	-55° C to +125° C
Reverse Voltage (OPR2101)	25 V
Reverse Breakdown Voltage (OPR2100)	50 V / minute
Solder reflow time within 5°C of peak temperature is 20 to 40 seconds ⁽¹⁾	250° C

Electrical Characteristics ($T_A = 25^\circ\text{C}$ unless otherwise noted)

SYMBOL	PARAMETER	MIN	TYP	MAX	UNITS	TEST CONDITIONS	
R_λ	Responsivity	0.45	-	-	A/W	$\Phi_E = 10\ \mu\text{W}$, $\lambda = 890\ \text{nm}$, $V = 0\ \text{V}$	
$V_{(BR)R}$	Reverse Breakdown Voltage	50	-	-	V	$I_R = 10\ \mu\text{A}$	
I_D	Reverse Dark Current	-	-	10	nA	$V_R = 10\ \text{V}$ $V_R = 10\ \text{V}$, $\Phi_E = 0$ $V_R = 10\ \text{V}$, $\Phi_E = 0$, $T_A = 125^\circ\text{C}$	
	OPR2100	-	-	5	nA		
	OPR2101	-	5	-	μA		
C_T	Capacitance	-	10	-	pf	$V_R = 10\ \text{V}$	
$L_x W$	Active Area (per diode)	OPR2100	-	3.45	-	mm^2	2.73 mm x 1.34 mm
		OPR2101	-	0.84	-	mm^2	1.23 mm x .72 mm

Notes:

- Solder time less than 5 seconds at temperature extreme.

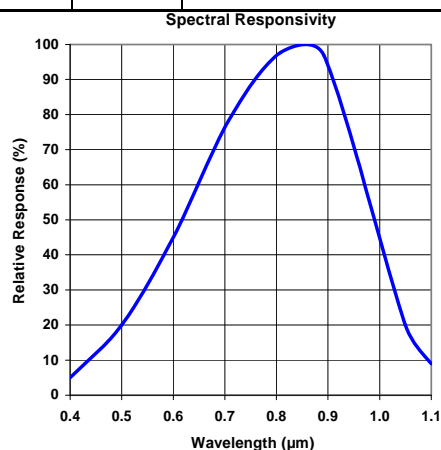

OPTEK reserves the right to make changes at any time in order to improve design and to supply the best product possible.