

S32K3XX

S32K3xx Data Sheet

Supports S32K312, S32K344, S32K324, and S32K314. Data is preliminary for S32K311, S32K322, S32K341, S32K342, S32K328, S32K338, S32K348, S32K358.

Rev. 4 — 04/2022

Data Sheet: Technical Data

- Operating characteristics
 - Voltage range: 2.97 V to 5.5 V
 - Ambient temperature range: -40 °C to 125 °C for all power modes
- Arm™ Cortex-M7 core, 32-bit CPU
 - M7 supports up to 160 MHz frequency with 2.14 DMIPS / MHz
 - Arm Core based on the Armv7 and Thumb®-2 ISA
 - Integrated Digital Signal Processor (DSP)
 - Configurable Nested Vectored Interrupt Controller (NVIC)
 - Single Precision Floating Point Unit (FPU)
- Clock interfaces
 - 8 - 40 MHz Fast External Oscillator (FXOSC)
 - 48 MHz Fast Internal RC oscillator (FIRC)
 - 32 kHz Low Power Oscillator (SIRC)
 - 32 kHz Slow External Oscillator (SXOSC)
 - System Phased Lock Loop (SPLL)
- I/O and package
 - LQFP48, MAXQFP100, MAXQFP172, MAPBGA257, MAPBGA289, MaxQFP172 with Exposed pad (EP) package options
- Up to 32-channel DMA with up to 128 request sources using DMAMUX
- Memory and memory interfaces
 - Up to 8 MB program flash memory with ECC
 - Up to 128 K of flexible program or data flash memory
 - Up to 512 KB SRAM with ECC, includes 192 KB of TCM RAM ensuring maximum CPU performance of fast control loops with minimal latency
 - Data and instruction cache for each core to minimize performance impact of memory access latencies
 - QuadSPI support
- Mixed-signal analog
 - Up to three 12-bit Analog-to-Digital Converters (ADC) with up to 24 channel analog inputs per module
 - One Temperature Sensor (TempSense)
 - Up to three Analog Comparators (CMP), with each comparator having an internal 8-bit DAC
- Human-Machine Interface (HMI)
 - Up to 235 GPIO pins
 - Non-Maskable Interrupt (NMI)
 - Up to 60 pins with wakeup capability
 - Up to 32 pins with interrupt support



- Power management
 - Low-power Arm Cortex-M7 core with excellent energy efficiency, balanced with performance
 - Power Management Controller (PMC) with simplified mode management (RUN and STANDBY)
 - Supports peripheral specific clock gating. Only specific peripherals remain working in low power modes.
- Communications interfaces
 - Up to 16 serial communication interface (LPUART) modules, with LIN, UART and DMA support
 - Up to six Low Power Serial Peripheral Interface (LPSPI) modules with DMA support
 - Up to two Low Power Inter-Integrated Circuit (LPI2C) modules with DMA support
 - One Improved Inter-Integrated Circuit (I3C) module with DMA support
 - Up to six FlexCAN modules (with optional CAN-FD support)
 - FlexIO module for flexible and high performance serial interfaces
 - One Ethernet module
 - Up to two Synchronous Audio Interface (SAI) modules
- Reliability, safety and security
 - Hardware Security Engine (HSE_B)
 - Up to two Internal Software Watchdog Timers (SWT)
 - Error-Correcting Code (ECC) on all memories
 - Error Detection Code (EDC) on data path
 - Cyclic Redundancy Check (CRC) module
 - 120-bit Unique Identification (ID) number
 - Extended Cross domain Domain Controller (XRDC), providing protection for master core access rights
 - Virtualization Wrapper (VIRT_WRAPPER), providing I/O protection
- Debug functionality
 - Serial Wire JTAG debug Port (SWJ-DP), with 2 pin Serial Wire Debug (SWD) for external debugger
 - Debug Watchpoint and Trace (DWT), with four configurable comparators as hardware watchpoints
 - Serial Wire Output (SWO)-synchronous trace data support
 - Instrumentation Trace Macrocell (ITM) with software and hardware trace, plus time stamping
 - CoreSight AHB Trace Macrocell (HTM)
 - Flash Patch and Breakpoints (FPB) with ability to patch code and data from code space to system space
 - Serial Wire Viewer (SWV): A trace capability providing displays of reads, writes, exceptions, PC Samples and print
 - Full data trace for up to 16 output wide
 - Embedded Cross Trigger (ECT) is used for multicore run-control and trace cross triggering, using CoreSight Cross Trigger Interface (CTI)
- Timing and control
 - Up to three enhanced modular I/O system (eMIOS), offering up to 72 timer channels (IC/OC/PWM)
 - Up to two System Timer Modules (STM)
 - Up to two Logic Control Units (LCU)
 - Full cross triggering support for ADC / timer (BCTU)
 - One Trigger MUX Control (TRGMUX) module
 - Up to three Periodic Interrupt Timer (PIT) modules
 - 32-bit Real Time Counter (RTC) with autonomous periodic interrupt (API) function

Contents

1	Overview.....	4	9.5	Flash memory read timing parameters.....	74
2	Block diagram.....	4	10	Analog modules.....	75
3	Feature comparison.....	10	10.1	SAR ADC.....	75
4	Ordering information.....	14	10.2	Supply Diagnosis.....	78
4.1	Determining valid orderable parts	14	10.3	Low Power Comparator (LPCMP).....	78
5	General.....	14	10.4	Temperature Sensor.....	82
5.1	Absolute maximum ratings.....	15	11	Clocking modules.....	83
5.2	Voltage and current operating requirements.	16	11.1	FIRC.....	83
5.3	Thermal operating characteristics.....	18	11.2	SIRC.....	83
5.4	ESD and Latch-up Protection Characteristics	18	11.3	PLL.....	83
6	Power management.....	19	11.4	Fast External Oscillator (FXOSC).....	85
6.1	Power management system - S32K344, S32K324, S32K341, S32K314, S32K342, and S32K322.....	20	11.5	Slow Crystal Oscillator (SXOSC).....	86
6.2	Power management system - S32K312, S32K311.....	21	12	Communication interfaces.....	87
6.3	Power management system - S32K358.....	22	12.1	LPSPi.....	87
6.4	Power mode transition operating behaviors..	22	12.1.1	LPSPi.....	87
6.4.1	Power mode transition operating behaviour.	22	12.1.2	LPSPi0 20 MHz and 15 MHz Combinations.	91
6.4.2	Boot time, HSE firmware not installed.....	23	12.2	I ² C.....	92
6.4.3	Boot time, HSE firmware installed.....	23	12.3	I3C Push-Pull Timing Parameters for SDR Mode.....	92
6.4.4	HSE firmware memory verification time examples.....	24	12.4	FlexCAN characteristics.....	94
6.5	Supply Monitoring.....	29	12.5	SAI electrical specifications.....	94
6.6	SMPS regulator electrical specifications.....	30	12.5.1	SAI Electrical Characteristics, Slave Mode..	94
6.7	Recommended Decoupling Capacitors.....	31	12.5.2	SAI Electrical Characteristics, Master Mode.	96
6.8	NPN Ballast Transistor Control Specification	42	12.6	Ethernet characteristics.....	97
6.9	Supply currents.....	42	12.6.1	Ethernet MII (100 Mbps).....	97
6.10	Operating mode.....	58	12.6.2	Ethernet MII (200 Mbps).....	99
6.11	Cyclic wake-up current	60	12.6.3	Ethernet RMII.....	101
7	I/O parameters.....	60	12.6.4	Ethernet RGMII.....	103
7.1	GPIO DC electrical specifications, 3.3V Range (2.97V - 3.63V).....	60	12.6.5	MDIO timing specifications.....	104
7.2	GPIO DC electrical specifications, 5.0V (4.5V - 5.5V).....	64	12.7	QuadSPi.....	105
7.3	5.0V (4.5V - 5.5V) GPIO Output AC Specification.....	68	12.7.1	QuadSPi Quad 3.3V SDR 120MHz.....	105
7.4	3.3V (2.97V - 3.63V) GPIO Output AC Specification.....	69	12.7.2	QuadSPi Octal 3.3V DDR 100MHz.....	107
8	Glitch Filter.....	70	12.7.3	QuadSPi Octal 3.3V DDR 120MHz.....	108
9	Flash memory specification.....	71	12.8	uSDHC.....	109
9.1	Flash memory program and erase specifications.....	71	12.8.1	uSDHC SDR electrical specifications.....	109
9.2	Flash memory Array Integrity and Margin Read specifications.....	72	12.8.2	uSDHC DDR electrical specifications.....	110
9.3	Flash memory module life specifications.....	73	12.9	LPUART specifications.....	112
9.3.1	Data retention vs program/erase cycles.....	73	13	Debug modules.....	112
9.4	Flash memory AC timing specifications.....	74	13.1	Debug trace timing specifications.....	112
			13.2	SWD electrical specifications.....	113
			13.3	JTAG electrical specifications.....	114
			14	Thermal Attributes.....	116
			14.1	Description.....	116
			14.2	Thermal characteristics.....	117
			15	Dimensions.....	117
			15.1	Obtaining package dimensions.....	118
			16	Revision history.....	118
				Legal information.....	127

1 Overview

The S32K3xx product series further extends the highly-scalable portfolio of Arm® Cortex® - M0+/M4F S32K1xx chips in the automotive industry with the Arm Cortex-M7 core at higher frequency, more memory, ASIL-B and D rating and advanced security module. With a focus on automotive environment robustness, the S32K3xx product series devices are well suited to a wide range of applications in electrical harsh environments, and are optimized for cost-sensitive applications offering new, space saving package options. The S32K3xx series offers a broad range of memory, peripherals and performance options. Devices in this series share common peripherals and pin-out, allowing developers to migrate easily within a chip series or among other chip series to take advantage of more memory or feature integration.

CAUTION

S32K3x1, S32K322, S32K342 and S32K3x8 specific information is preliminary until these devices are qualified and may change without notice.

2 Block diagram

The following figures show the S32K3xx product series block diagrams [1]

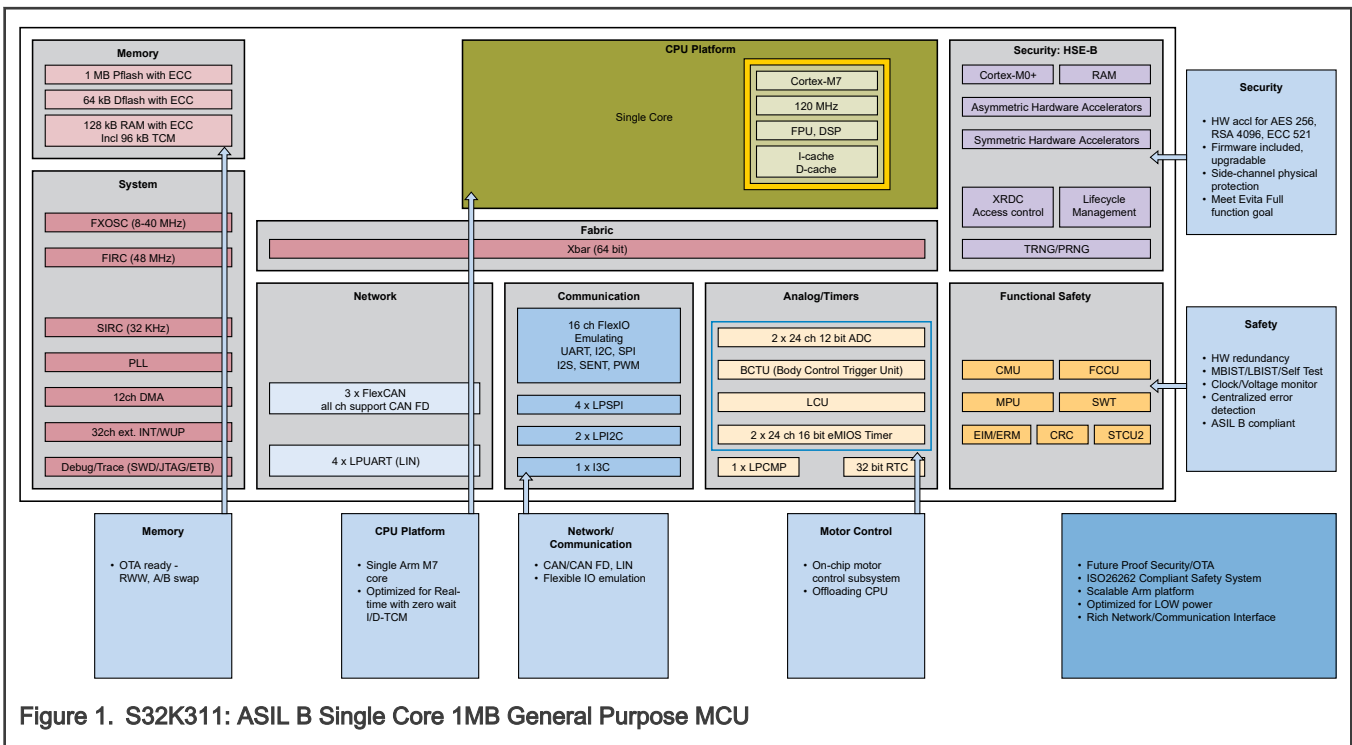

[1] See Table 1 for device specific values.

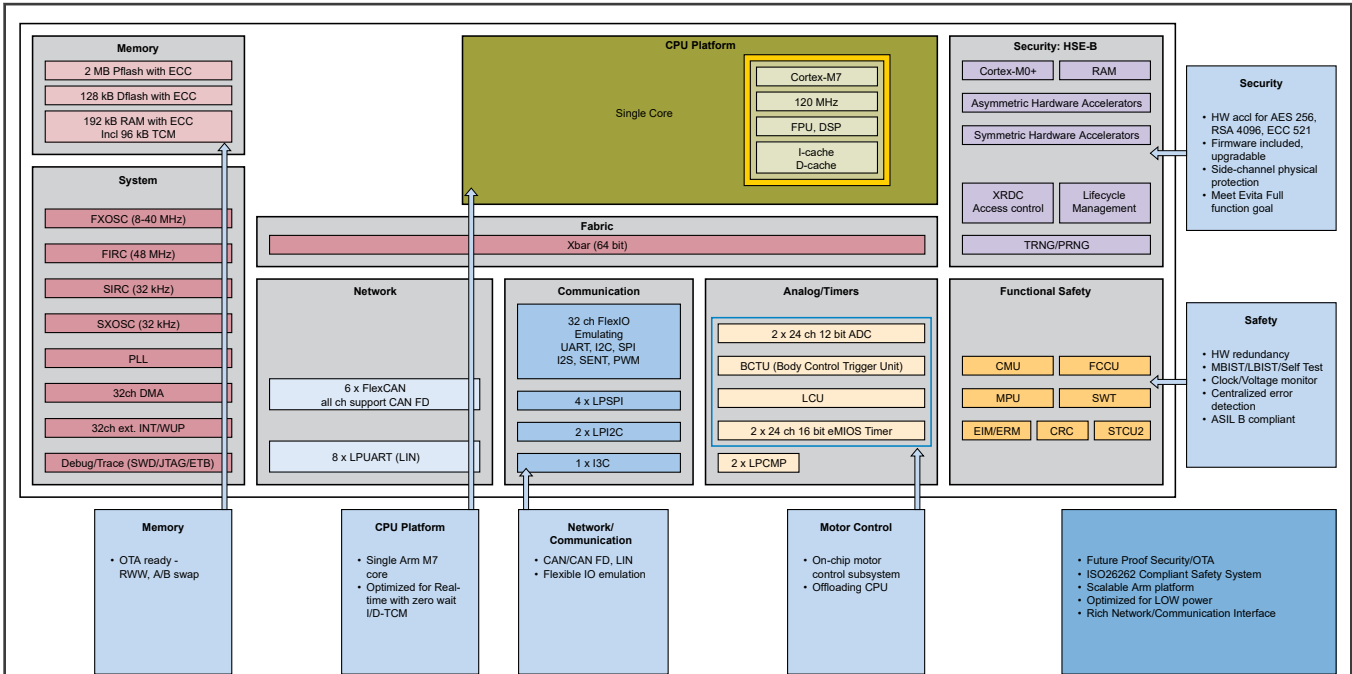

Figure 2. S32K312: ASIL B Single Core 2MB General Purpose MCU

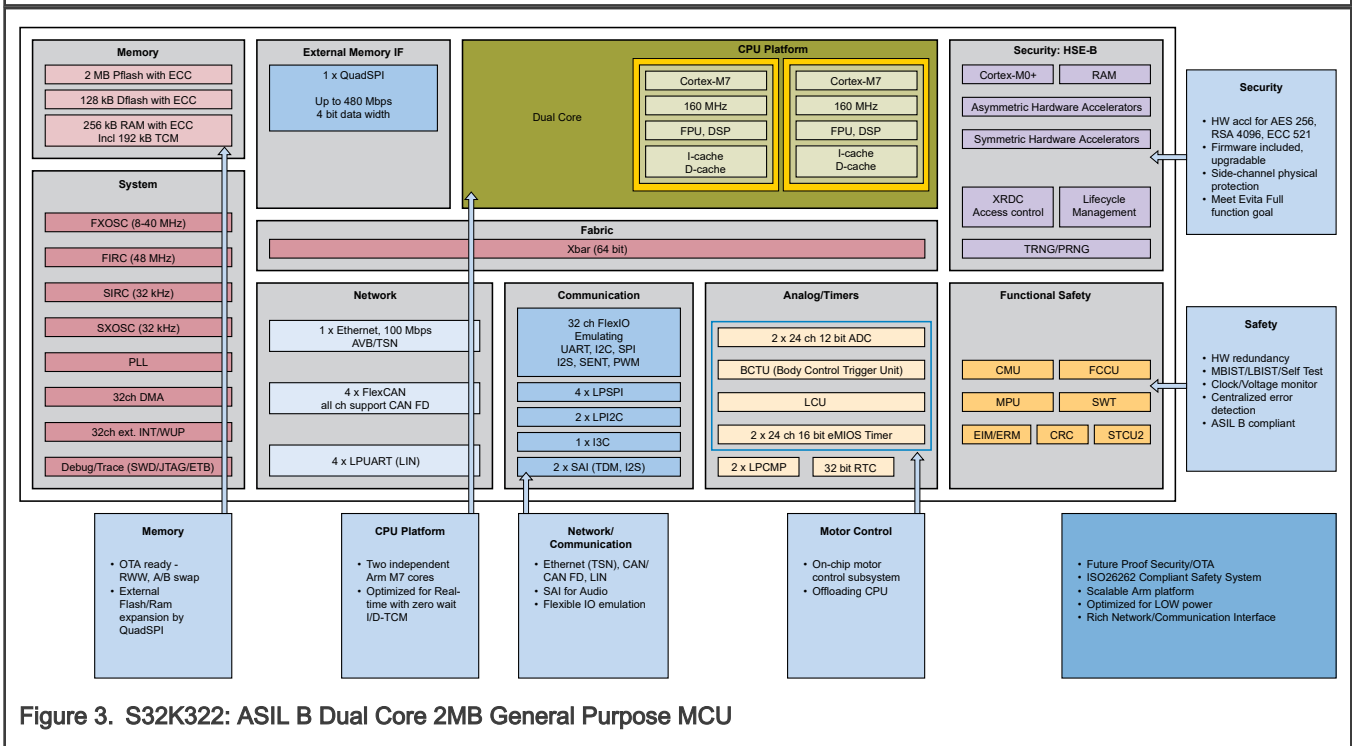

Figure 3. S32K322: ASIL B Dual Core 2MB General Purpose MCU

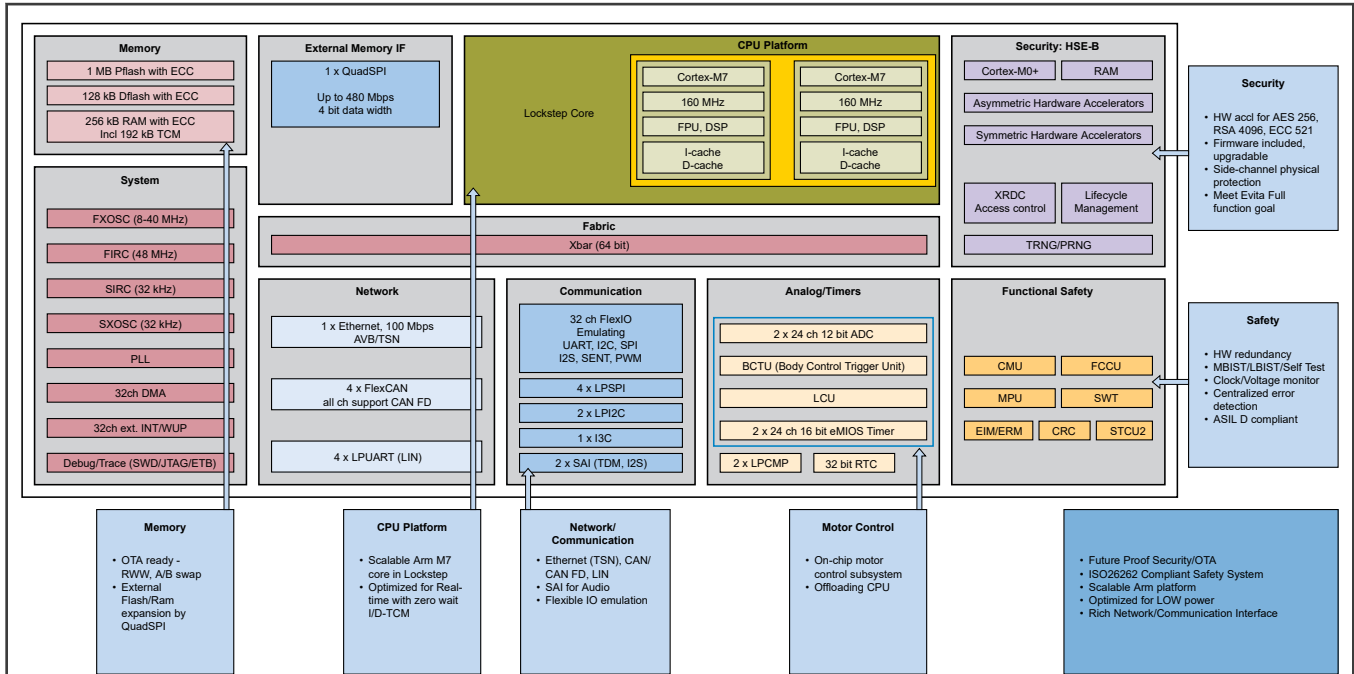

Figure 4. S32K341: ASIL D Lockstep Core 1MB General Purpose MCU

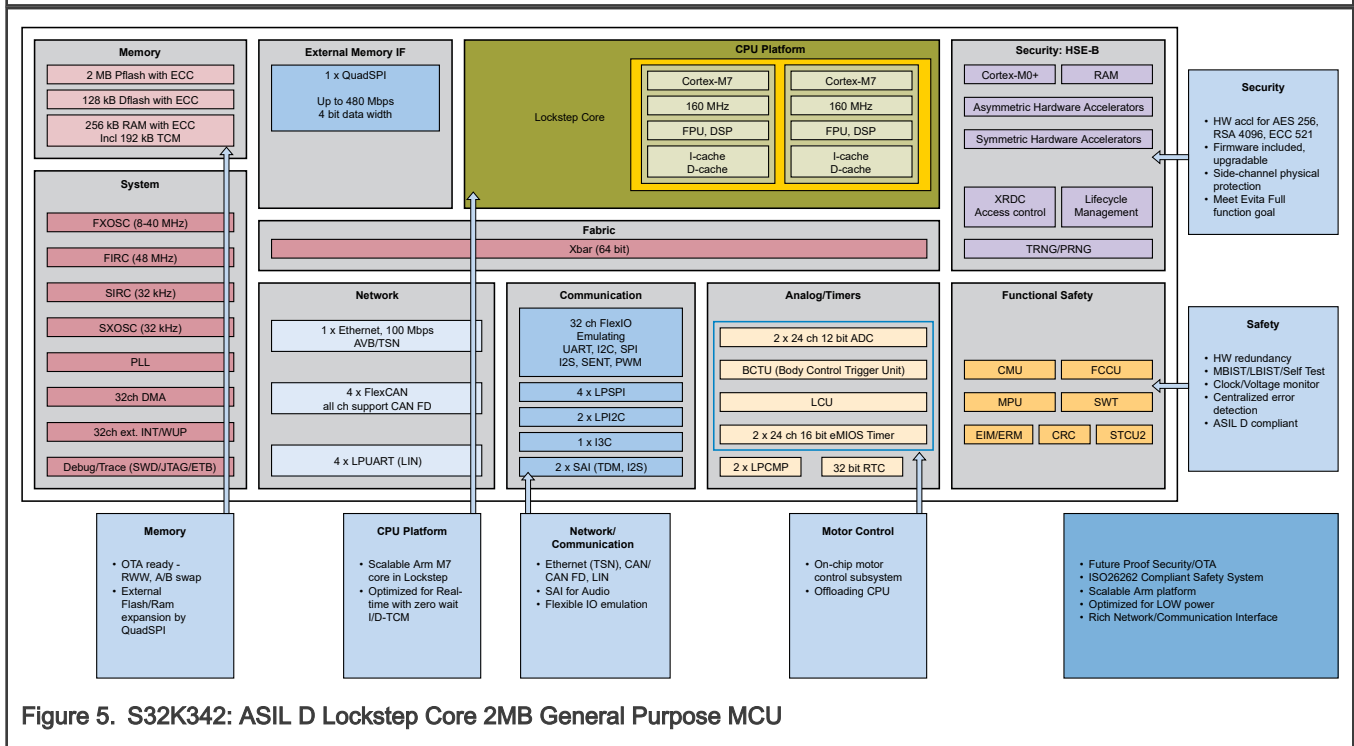

Figure 5. S32K342: ASIL D Lockstep Core 2MB General Purpose MCU

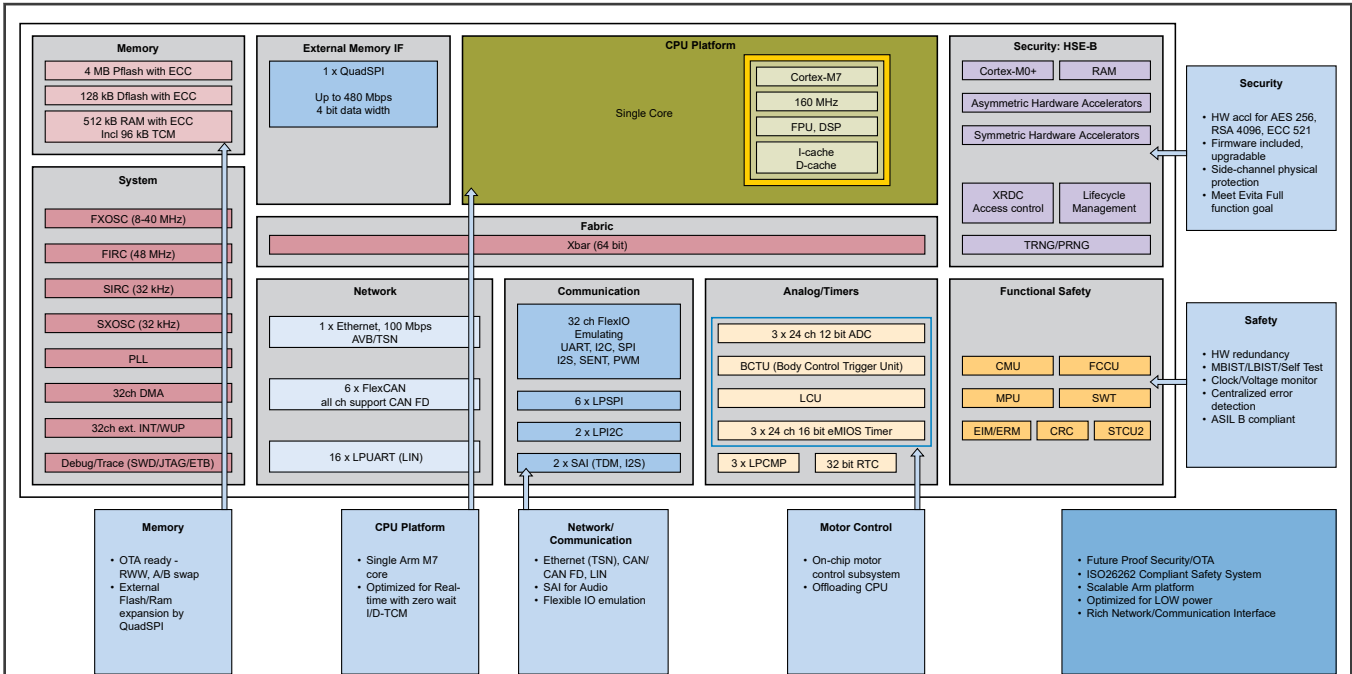

Figure 6. S32K314: ASIL B Single Core 4MB General Purpose MCU

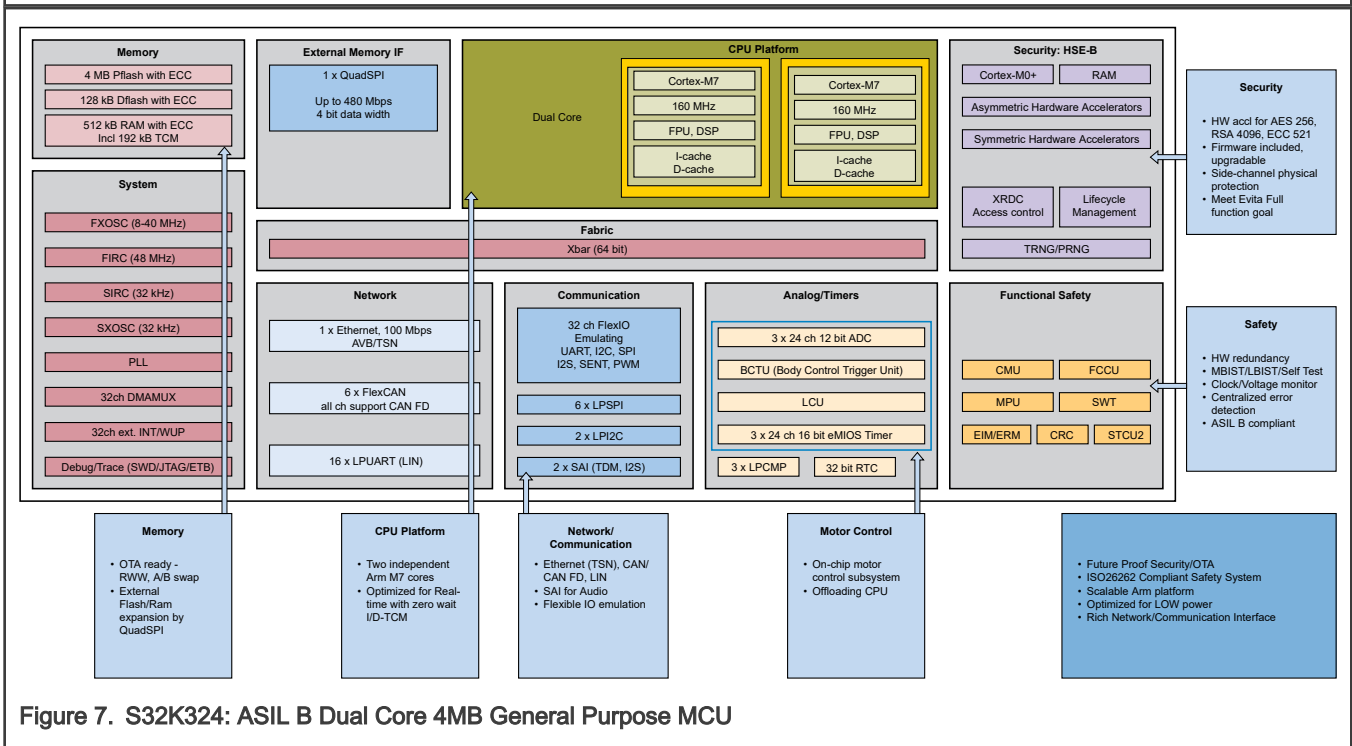

Figure 7. S32K324: ASIL B Dual Core 4MB General Purpose MCU

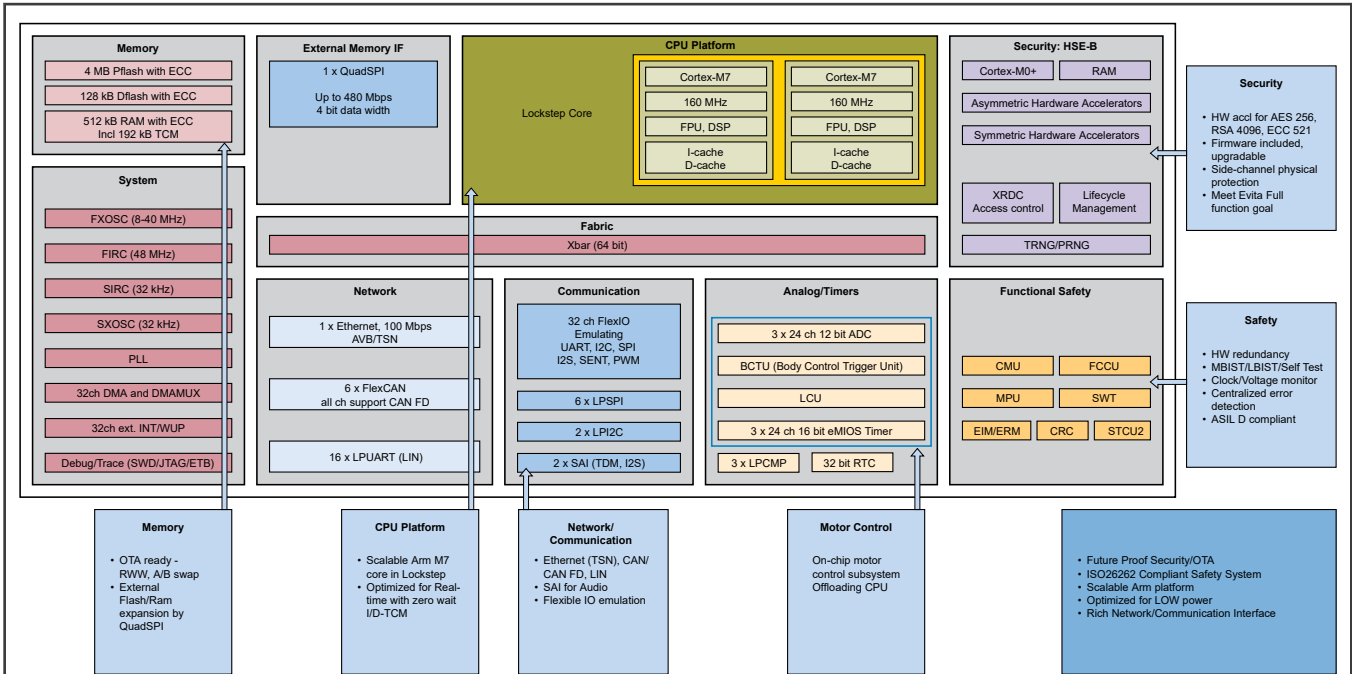

Figure 8. S32K344: ASIL D Lockstep Core 4MB General Purpose MCU

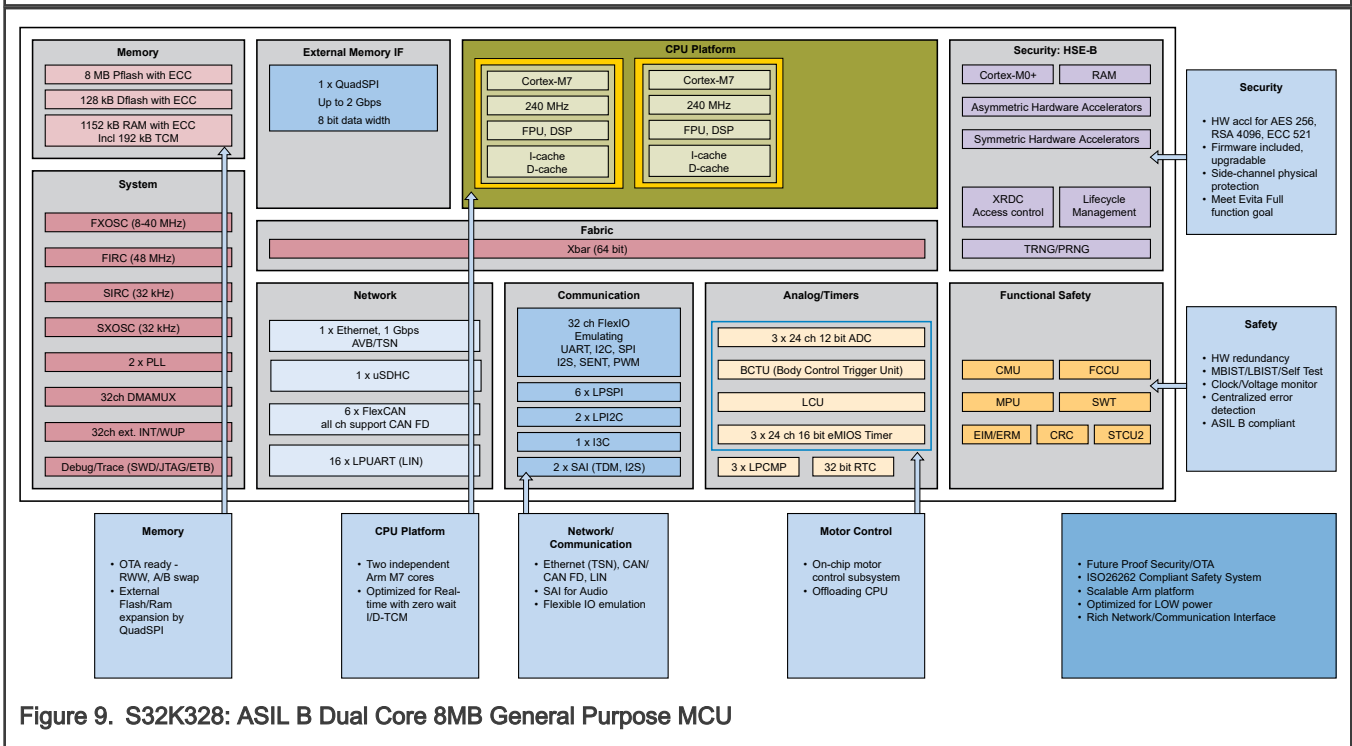

Figure 9. S32K328: ASIL B Dual Core 8MB General Purpose MCU

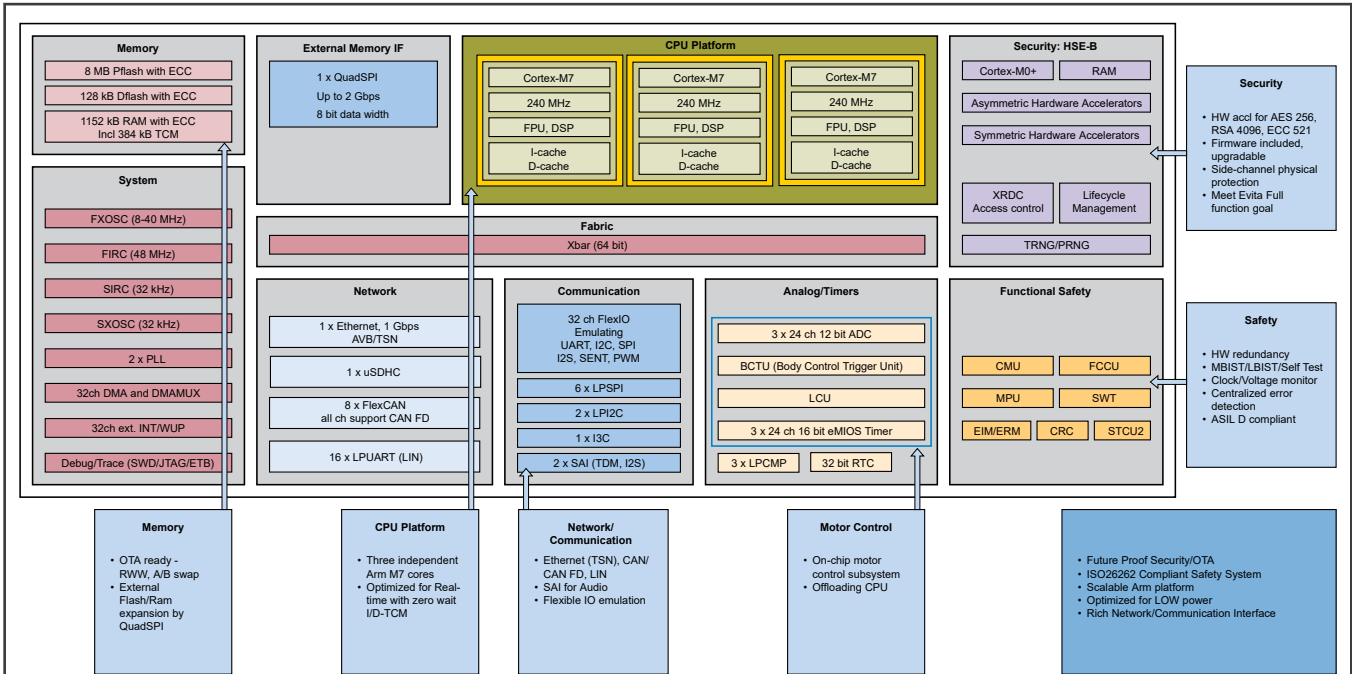

Figure 10. S32K338: ASIL B Three Core 8MB General Purpose MCU

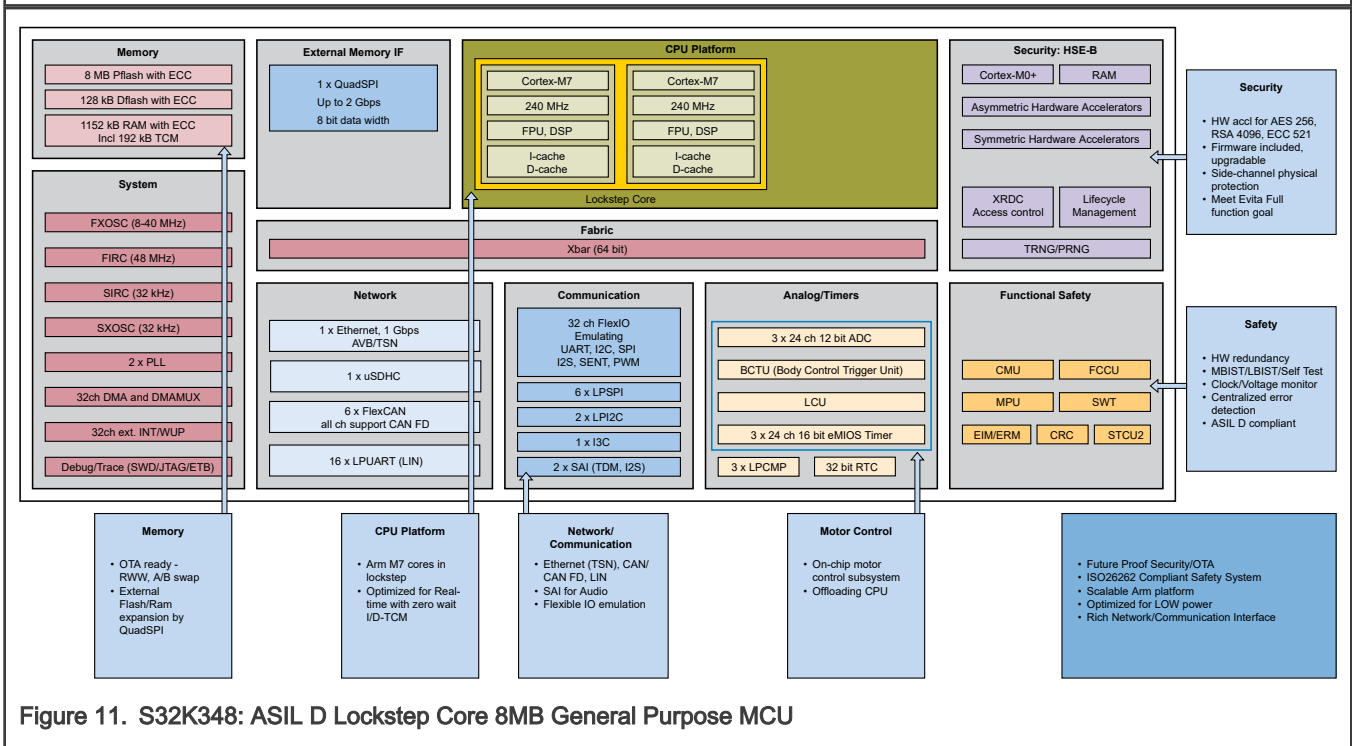
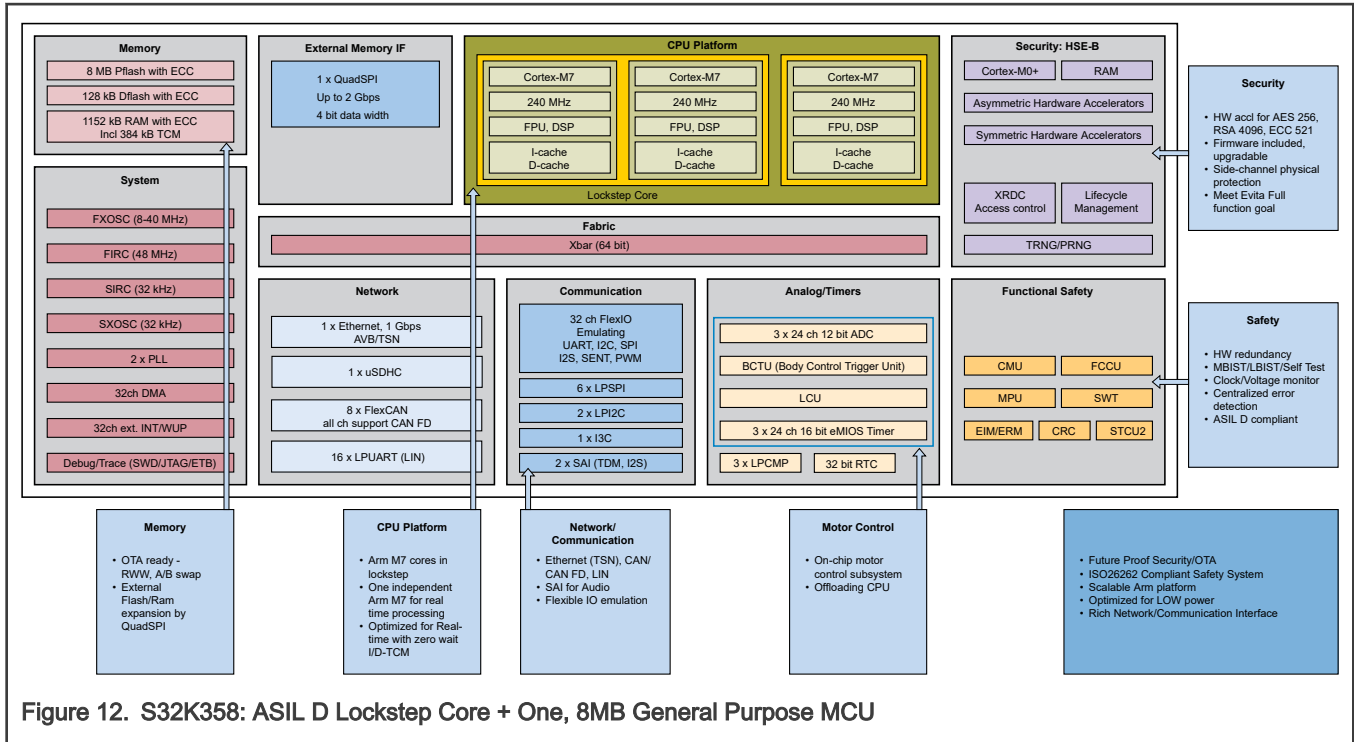

Figure 11. S32K348: ASIL D Lockstep Core 8MB General Purpose MCU



3 Feature comparison

The following table compares some of the prominent features related to memory and package options of the chips from the S32K3xx family/product series.

Table 1. S32K3xx chip's feature comparison

Feature	Chip											
	S32K311	S32K312	S32K322	S32K341	S32K342	S32K314	S32K324	S32K344	S32K328 ¹	S32K338 ²	S32K348 ³	S32K358 ⁴
Safety/ASIL	B			D		B		D	B	B	D	D
Program flash memory (MB)	1	2		1	2	4			8			
Data flash memory (KB)	64	128						128				
Total RAM (KB)	128 KB (including 96 KB TCM)	192 KB (including 96 KB TCM)	256 KB (including 192 KB TCM)		512 KB (including 96 KB TCM)	512 KB (including 192 KB TCM)		1152 KB (including 192 KB TCM)	1152 KB (including 384 KB TCM)	1152 KB (including 192 KB TCM)	1152 KB (including 384 KB TCM)	
Standby RAM	32 KB							64 KB				
Security	HSE_B							HSE_B				
Core quantity	1 x Cortex-M7		2 x Cortex-M7	1 x Cortex-M7 LS		1 x Cortex-M7	2 x Cortex-M7	1 x Cortex-M7 LS	2 x Cortex-M7	3 x Cortex-M7	1 x Cortex-M7 LS	1 x Cortex-M7 LS + 1 x Cortex-M7
Frequency (MHz)	120		160						160	240	160	240
DMA channels	12		32						32			
ASIL-B DMIPS ⁵	256–387		684–1033	—		342–516	684–1033	—	684–1033	1539–2325	—	513–775 ⁶
ASIL-D DMIPS ⁵	—			342–516		—		342–516	—		342–516	513–775 ⁶
ASIL-B CoreMark score ⁷	584		1558	—		779	1558	—	1558	3506	—	1168 ⁶
ASIL-D CoreMark score ⁷	—			779		—		779	—		779	1168 ⁶

Table continues on the next page...

Table 1. S32K3xx chip's feature comparison (continued)

Feature	Chip											
	S32K311	S32K312	S32K322	S32K341	S32K342	S32K314	S32K324	S32K344	S32K328 ¹	S32K338 ²	S32K348 ³	S32K358 ⁴
FlexCAN instances	3	6	4			6			8			
EMAC instances	0		1						0			
GMAC instances	0								1			
SAI instances	0		2						2			
LPUART instances	4	8	4			16			16			
LPSPIC instances	4					6			6			
I ² C instances	2								2			
I ³ C instances	1					—			1			
FlexIO (incl. SENT support) channels	16	32									32	
QuadSPI instances	0		1 ⁸						1 ⁹			
uSDHC instances	0								1			
ADC instances	2					3			3			
LPCMP instances	1	2				3			3			
PIT instances	2		3						3			
SWT instances	1	2	1			2	1	2	3	1	2	
STM instances	1		2						3			

Table continues on the next page...

Table 1. S32K3xx chip's feature comparison (continued)

Feature	Chip												
	S32K311	S32K312	S32K322	S32K341	S32K342	S32K314	S32K324	S32K344	S32K328 ¹	S32K338 ²	S32K348 ³	S32K358 ⁴	
LCU instances	2						2						
BCTU instances	1						1						
TRGMUX instances	1						1						
eMIOS instances	2				3				3				
RTC instances	Yes						Yes						
289-ball MAPBGA package	No						Yes						
257-ball MAPBGA package	No						Yes						
172-MAX QFP package	No	Yes						Yes ¹⁰					
100-MAX QFP package	Yes						No						
48-pin LQFP package	Yes	No						No					

1. The S32K328 feature set is under evaluation and subject to change.
2. The S32K338 feature set is under evaluation and subject to change.
3. The S32K348 feature set is under evaluation and subject to change.
4. The S32K358 feature set is under evaluation and subject to change.
5. Final DMIPS is in range base on complier setting. Low number is using "ground rules" laid out in the Dhrystone documentation. High number is using inlining of functions a simultaneous ("multi-file") compilation.
6. ASIL-B and ASIL-D performance is available simultaneously.
7. Result depends on specific compiler version, contact NXP sales representative for more details.
8. 4-bit data width
9. 8-bit data width
10. 172 MAXQFP-EP (exposed pad)

4 Ordering information

Figure 13. Ordering information

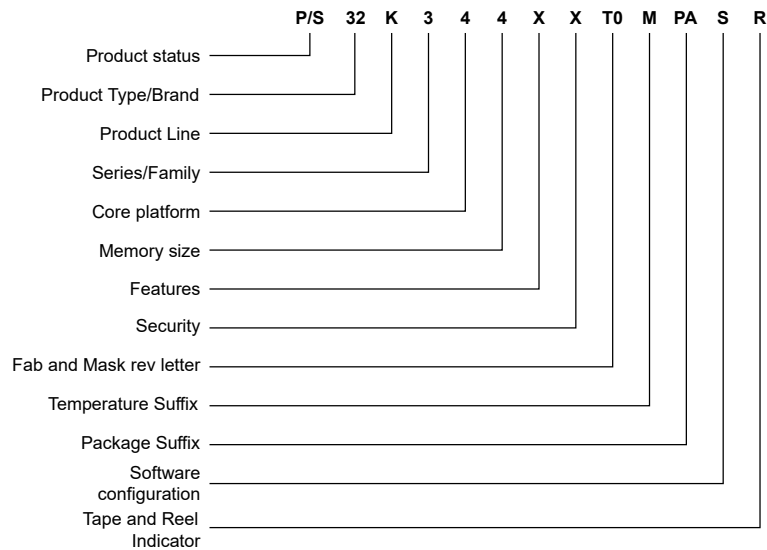

Product status

P: Prototype
S: Qualified ordering P/N

Product Type/Brand

32: Automotive 32-bit MCU/MPU

Product Line

K: General purpose MCU

Series/Family

3: K3 product family/ARM CortexM7 based

Core platform

- 1: 1 x M7 Core
- 2: 2 x M7 Cores
- 3: 3 x M7 Cores
- 4: 1 x M7 lockstep core
- 5: 1 x M7 lockstep core plus 1 x M7 core

Memory Size

	1	2	4	8
P-Flash	1 MB	2 MB	4 MB	8 MB

Features

Ethernet Feature

No Ethernet MAC	100 Mbps Ethernet MAC
N	E

Security

Flex SHE	HSE B	Customised Security
N	H	TBD

Fab and Mask rev letter

Tx: Global Foundry
x0: 1st fab revision
x1: 2nd fab revision

Temperature Suffix

V: -40 °C to 105 °C
M: -40 °C to 125 °C

Package Suffix

pins	BGA	MaxQFP	MaxQFP-EP	LQFP
48	-	-	-	LF
100	-	PA	-	-
172	-	PB	PC	-
257	MM	-	-	-
289	JB	-	-	-

Software Configuration

S: Standard Family SW Package, including:

- Real time driver including combined SDK & Autosar MCAL (ISO26262, crypto driver included)
- Standard Security Firmware

I: ISELED SW licensed + Standard Family SW Package

Additional solution specific SW TBD

Tape and Reel Indicator

T: Trays/Tubes
R: Tape & Reel

4.1 Determining valid orderable parts

To determine the orderable part numbers for this device, please contact NXP sales representative.

5 General

5.1 Absolute maximum ratings

CAUTION

When the MCU is in an unpowered state, current injected through the chip pins may bias internal chip structures (for example, ESD diodes) and incorrectly power up these internal structures through inadvertent paths. The presence of such residual voltage may influence different chip-internal blocks in an unpredictable manner and may ultimately result in unpredictable chip behavior (for example, POR flag not set). Once in the illegal state, powering up the chip further and then applying reset will clear the illegal state. Injection current specified for the chip under the aspect of absolute maximum ratings represent the capability of the internal circuitry to withstand such condition without causing physical damage. Functional operation of the chip under conditions - specified as absolute maximum ratings - is not implied.

NOTE

Functional operating conditions appear in the DC electrical characteristics. Absolute maximum ratings are stress ratings only, and functional operation at the maximum values is not guaranteed. See footnotes in the following table for specific conditions. Stress beyond the listed maximum values may affect device reliability or cause permanent damage to the device. All the limits defined in the datasheet specification must be honored together and any violation to any one or more will not guarantee desired operation. Unless otherwise specified, all maximum and minimum values in the datasheet are across process, voltage, and temperature.

The VDD_HV_B and V15 voltage supply domains are only present in certain devices and packages (S32K358, S32K348, S32K338, S32K328, S32K344, S32K324, S32K314, S32K342, S32K341, S32K322).

The VDD_DCDC supply voltage is only present in certain devices and packages (S32K358, S32K348, S32K338, S32K328).

Table 2. Absolute maximum ratings

Symbol	Description	Min	Typ	Max	Unit	Condition	Spec Number
VDD_HV_A	Main I/O and analog supply voltage ^{1,2}	-0.3	—	6.0	V	—	—
VDD_HV_B	Secondary I/O supply voltage ^{1,2}	-0.3	—	6.0	V	—	—
VDD_DCDC	Supply voltage for the SMPS gate driver ^{1,2}	-0.3	—	6.0	V	—	—
V15	High-current logic supply voltage ^{1,2}	-0.3	—	6.0	V	—	—
V25	Flash memory supply (2.5 V), internally regulated ¹	-0.3	—	2.9	V	—	—
V11	Core logic voltage supply (1.1 V), internally regulated ¹	-0.3	—	1.26	V	—	—
VREFH	ADC high reference voltage ^{1,2}	-0.3	—	6.0	V	—	—

Table continues on the next page...

Table 2. Absolute maximum ratings (continued)

Symbol	Description	Min	Typ	Max	Unit	Condition	Spec Number
VREFL	ADC low reference voltage ¹	-0.3	—	0.3	V	—	—
VGPIO_trans	Transient overshoot voltage allowed on I/O pin ^{1, 2, 3}	-	—	6.0	V	—	—
I_INJPAD_DC_ABS	Continuous DC input current (positive/negative) that can be injected into an I/O pin ⁴	-3	—	3	mA	—	—
I_INJSUM_DC_ABS	Sum of absolute value of injected currents on all the I/O pins (continuous DC limit) ⁴	—	—	30	mA	—	—
TSTG	Storage ambient temperature ⁵	-55	—	150	°C	—	—

1. All voltages are referred to VSS unless otherwise specified.
2. 6.0 V maximum for 10 hours over lifetime; 7.0 V maximum for 60 seconds over lifetime.
3. Absolute max rating must be honored under all conditions, including current injection.
4. When input pad voltage levels are close to VDD_HV_A (respectively to VDD_HV_B) or VSS, practically no current injection is possible. See application note AN4731 for a description of injection current on NXP automotive microcontrollers.
5. TSTG specifies the storage temperature range. It is not the operating temperature range. Please refer to the Thermal operating characteristics table.

5.2 Voltage and current operating requirements

NOTE

Device functionality is guaranteed down to the LVR assert level, however electrical performance of 12-bit ADC, CMP with 8-bit DAC, IO electrical characteristics, and communication modules electrical characteristics will be degraded when voltage drops below 2.97 V.

The VDD_HV_B and V15 voltage supply domains are only present in certain devices and packages (S32K358, S32K348, S32K338, S32K328, S32K344, S32K324, S32K314, S32K342, S32K341, S32K322).

The VDD_DCDC supply voltage is only present in certain devices and packages (S32K358, S32K348, S32K338, S32K328).

Table 3. Voltage and current operating requirements

Symbol	Description	Min	Typ	Max	Unit	Condition	Spec Number
VDD_HV_A	Main I/O and analog supply voltage ¹	2.97	3.3 or 5.0	5.5	V	—	—
VDD_HV_B	Secondary I/O supply voltage ¹	2.97	3.3 or 5.0	5.5	V	—	—

Table continues on the next page...

Table 3. Voltage and current operating requirements (continued)

Symbol	Description	Min	Typ	Max	Unit	Condition	Spec Number
VDD_DCDC	Supply voltage for the SMPS gate driver ¹	2.97	3.3 or 5.0	5.5	V	—	—
V15	High-current logic supply input voltage ¹	1.425	1.5	1.65	V	—	—
V15_extended	High-current logic supply input voltage, extended range ^{1, 2}	1.425	3.3 or 5.0	5.5	V	—	—
VREFH	ADC high reference voltage ^{1, 3}	2.97	3.3 or 5.0	5.5	V	—	—
VREFL	ADC low reference voltage ¹	-0.1	0	0.1	V	—	—
VSS_DCDC	Power ground for the SMPS gate driver ¹	-0.1	0	0.1	V	—	—
V25	Flash memory and clock supply (2.5 V), internally regulated ¹	—	2.5	—	V	—	—
V11	Core logic supply (1.1 V), internally regulated ¹	—	1.14	—	V	—	—
VGPIO	Input voltage range at any I/O or analog pin ¹	-0.3	—	VDD_HV_A/B + 0.3	V	—	—
VODPU	Open-drain pull-up voltage ^{1, 4}	—	—	VDD_HV_A/B	V	—	—
IINJPAD_DC_OP	Continuous DC input current (positive/negative) that can be injected into an I/O pin ⁵	-3	—	3	mA	VDD_HV_A >= 3.6V	—
IINJPAD_DC_OP	Continuous DC input current (positive/negative) that can be injected into an I/O pin ⁵	-2	—	3	mA	VDD_HV_A >= 2.97V	—
IINJSUM_DC_OP	Sum of absolute value of injected currents on all the I/O	-30	—	30	mA	VDD_HV_A >= 3.6V	—

Table continues on the next page...

Table 3. Voltage and current operating requirements (continued)

Symbol	Description	Min	Typ	Max	Unit	Condition	Spec Number
	pins (continuous DC limit) ⁵						
IINJSUM_DC_OP	Sum of absolute value of injected currents on all the I/O pins (continuous DC limit) ⁵	-20	—	30	mA	VDD_HV_A >= 2.97V	—
Vramp_slow	Supply ramp rate (slow) ^{1, 6}	0.5	—	—	V/min	—	—
Vramp_fast	Supply ramp rate (fast) ^{1, 6}	—	—	100	V/ms	—	—

1. All voltages are referred to VSS unless otherwise specified.
2. If total power dissipation and maximum junction temperature allows. Please refer to Thermal operating characteristics table for the maximum junction temperature, and Thermal characteristics table for the thermal characteristics, to determine the maximum power dissipation allowed for a given package.
3. VREFH should always be equal to or less than VDD_HV_A +0.1. Any positive differential voltage between VREFH and VDD_HV_A i.e., $VDD_HV_A < VREFH \leq VDD_HV_A + 0.1V$ is for RF-AC only. Appropriate decoupling capacitors should be used to filter noise on the supplies. See application note AN5032 for reference supply design for SAR ADC.
4. Open-drain outputs must be pulled respectively to their supply rail (VDD_HV_A or VDD_HV_B).
5. When input pad voltage levels are close to VDD_HV_A (respectively to VDD_HV_B) or VSS, practically no current injection is possible.
6. The MCU supply ramp rate parameter must be applicable to the MCU input/external supplies. The ramp rate assumes that the S32K3xx HW design guidelines in ANxxxx (TBD) are followed.

5.3 Thermal operating characteristics

Table 4. Thermal operating characteristics

Symbol	Description	Min	Typ	Max	Unit	Condition	Spec Number
Tamb	Ambient temperature	-40	—	125	°C	—	—
TJ	Junction temperature	-40	—	150	°C	—	—

5.4 ESD and Latch-up Protection Characteristics

Table 5. ESD and Latch-up Protection Characteristics

Symbol	Description	Min	Typ	Max	Unit	Condition	Spec Number
Vhbm	Electrostatic discharge voltage, human body model (HBM) ^{1, 2, 3}	-2000	—	2000	V	—	—

Table continues on the next page...

Table 5. ESD and Latch-up Protection Characteristics (continued)

Symbol	Description	Min	Typ	Max	Unit	Condition	Spec Number
Vcdm	Electrostatic discharge voltage, charged-device model (CDM), all pins except corner ^{1, 3, 4}	-500	—	500	V	—	—
Vcdm	Electrostatic discharge voltage, charged-device model (CDM), corner pins ^{1, 3, 4}	-750	—	750	V	—	—
Ilat	Latch-up current at ambient temperature of 125°C ⁵	-100	—	100	mA	—	—

1. Device failure is defined as: "If after exposure to ESD pulses, the device does not meet specification requirements."
2. This parameter is tested in conformity with AEC-Q100-002.
3. All ESD testing conforms with AEC-Q100 Stress Test Qualification for Automotive Grade Integrated Circuits.
4. This parameter is tested in conformity with AEC-Q100-011.
5. This parameter is tested in conformity with AEC-Q100-004.

6 Power management

6.1 Power management system - S32K344, S32K324, S32K341, S32K314, S32K342, and S32K322.

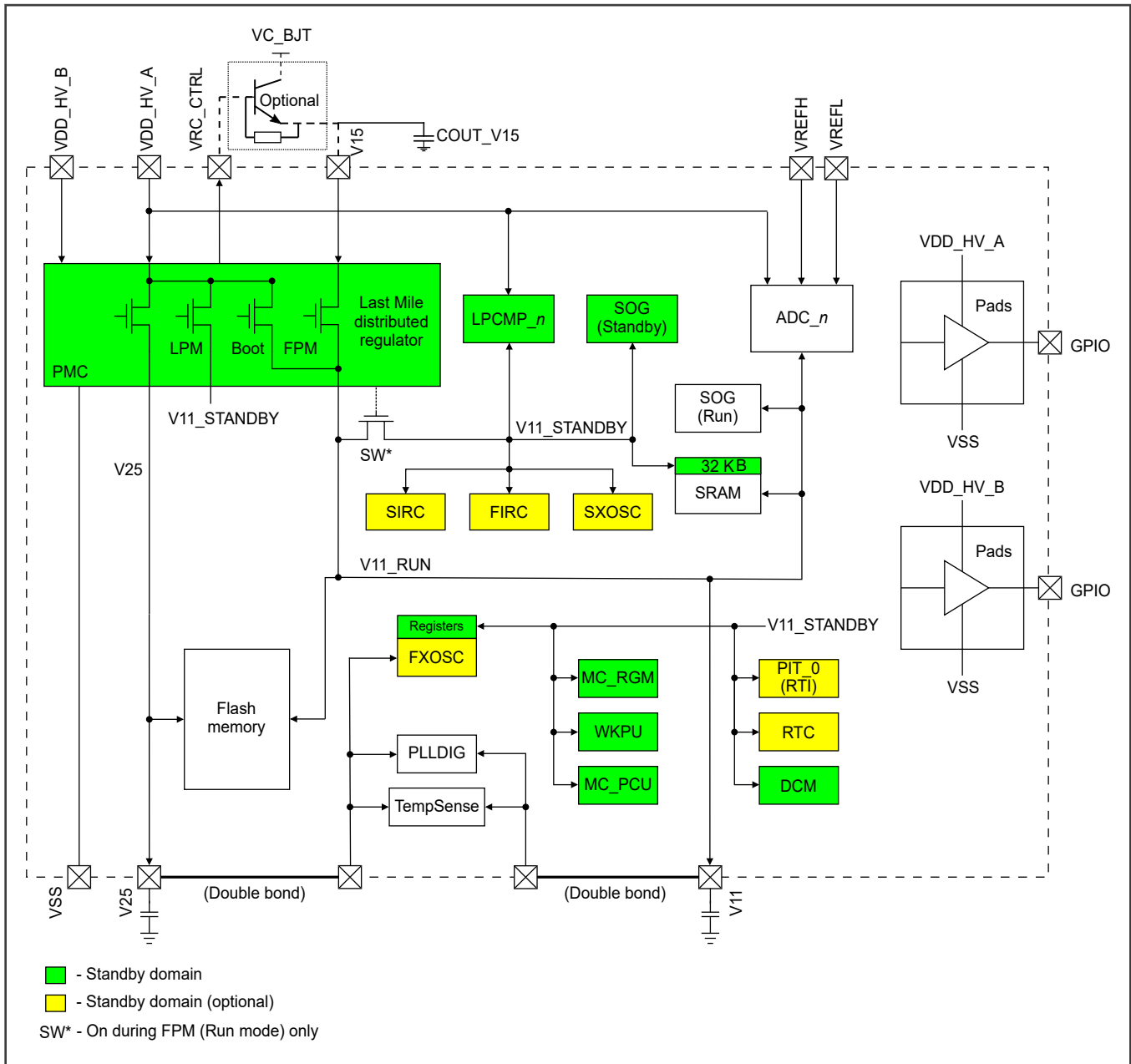

6.2 Power management system - S32K312, S32K311

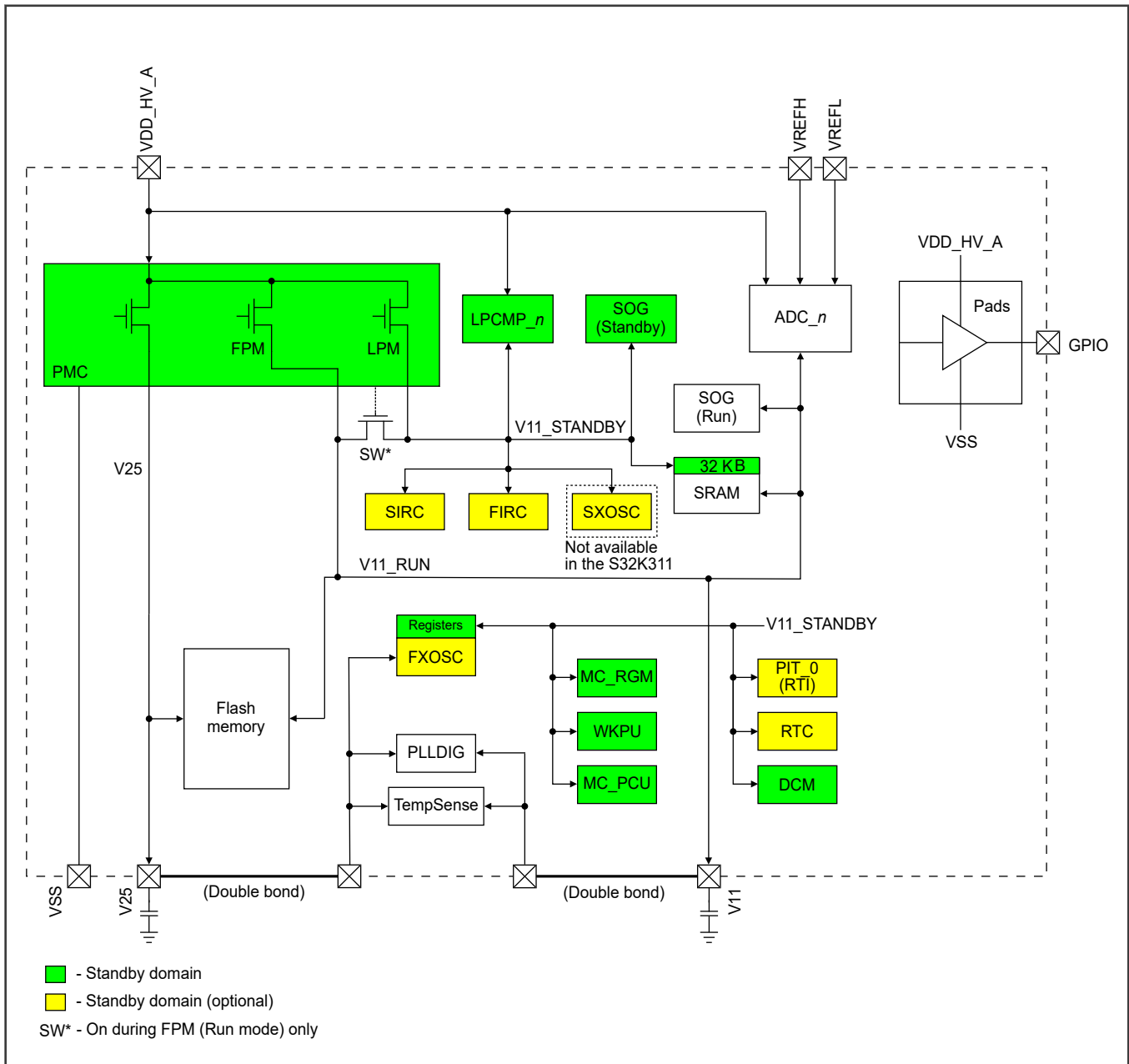

6.3 Power management system - S32K358

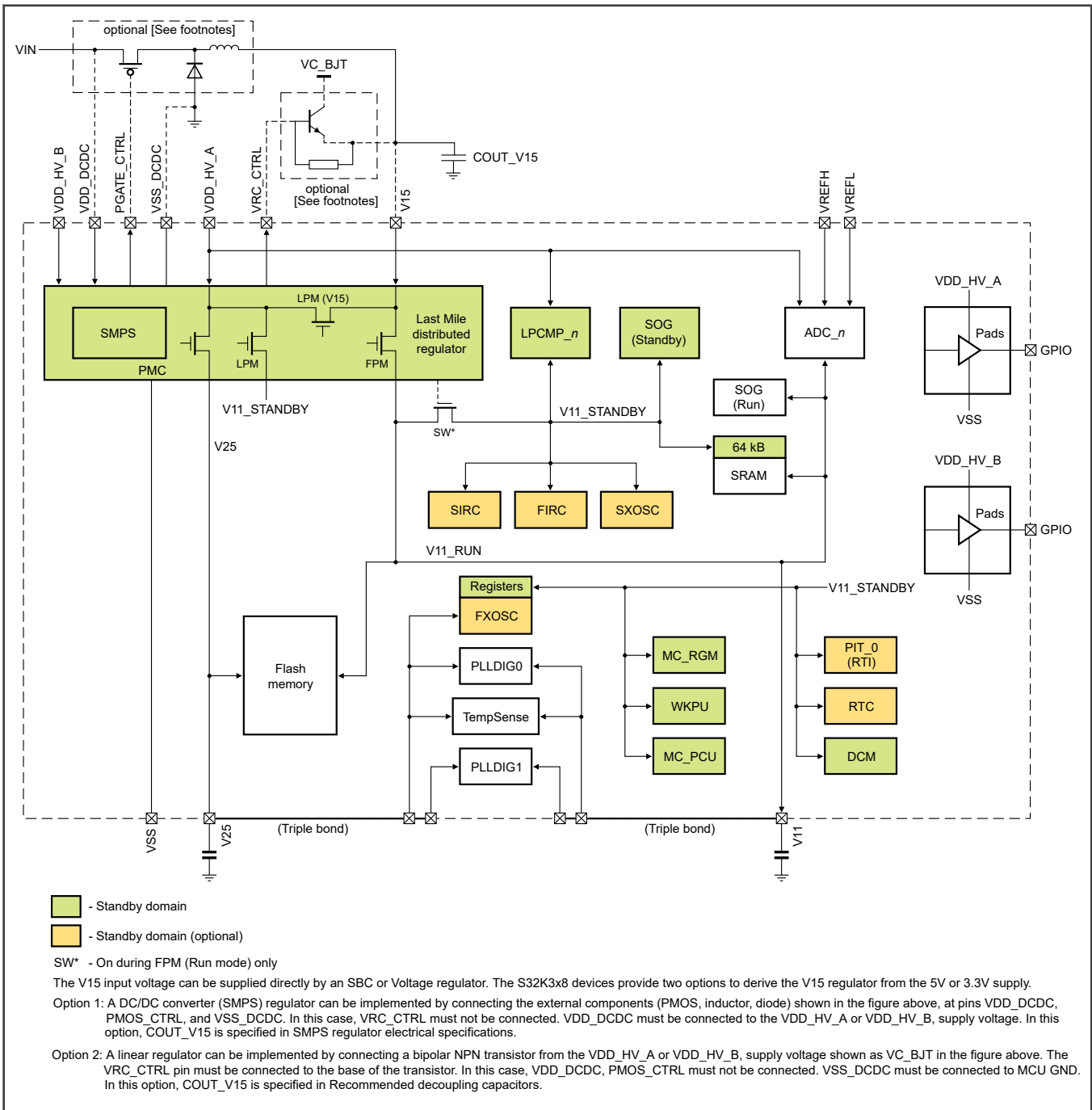

6.4 Power mode transition operating behaviors

6.4.1 Power mode transition operating behaviour

The values in the table below are provided for reference only.

Table 6. Power mode transition operating behaviour

Symbol	Description	Min	Typ	Max	Unit	Condition	Spec Number
tMODE_STDBYENTRY	RUN --> STANDBY transition time	—	955	—	ns	—	—
tMODE_STDBYEXIT_FAST	STANDBY --> RUN transition time, fast standby exit	—	53	—	us	—	—
tMODE_STDBYEXIT	STANDBY --> RUN transition time, normal standby exit	—	TBD	—	us	—	—

6.4.2 Boot time, HSE firmware not installed

Table 7. Boot time, HSE firmware not installed

Symbol	Description	Min	Typ	Max	Unit	Condition	Spec Number
tBOOT_noHSE	After a POR event, amount of time to execution of the first instruction of the application core, when HSE firmware is not installed. (HSE FW feature flag is disabled)	—	2	—	ms	FIRC 48MHz	—

6.4.3 Boot time, HSE firmware installed

The following table provides the boot time of the S32K3 SBAF and Firmware initialization. To obtain the total boot time, the corresponding user code verification time must be added.

Table 8. Boot time, HSE firmware installed

Symbol	Description	Min	Typ	Max	Unit	Condition	Spec Number
tBOOT_HSE_NONSECURE	After a POR event, amount of time to execution of the first instruction of the application core, when HSE firmware is installed BOOT SEQ = 0 Default configuration: CORE_CLK @ 48 MHz (source = FIRC	—	—	3	ms	—	—
tBOOT_HSE	After a POR event, amount of time to	—	12.36	—	ms	—	—

Table continues on the next page...

Table 8. Boot time, HSE firmware installed (continued)

Symbol	Description	Min	Typ	Max	Unit	Condition	Spec Number
	execution of the first instruction of the application core, when HSE firmware is installed. Default configuration: CORE_CLK @ 48 MHz (source = FIRC)						
tBOOT_HSE	After a POR event, amount of time to execution of the first instruction of the application core, when HSE firmware is installed. Optional configuration: CORE_CLK @ 120 MHz (source = PLL)	—	9.51	—	ms	—	—
tBOOT_HSE	After a POR event, amount of time to execution of the first instruction of the application core, when HSE firmware is installed. Optional configuration: CORE_CLK @ 80 MHz (source = PLL)	—	10.91	—	ms	—	—

6.4.4 HSE firmware memory verification time examples

Table 9. HSE firmware memory verification time examples

Symbol	Description	Min	Typ	Max	Unit	Condition	Spec Number
tCMAC_64KB	Memory verification of 64 KB of application firmware, using AES-128 CMAC cipher.	—	11.3	—	ms	FIRC 48MHz	—
tCMAC_1024KB	Memory verification of 1024 KB of application firmware, using AES-128 CMAC cipher.	—	176	—	ms	FIRC 48MHz	—

Table continues on the next page...

Table 9. HSE firmware memory verification time examples (continued)

Symbol	Description	Min	Typ	Max	Unit	Condition	Spec Number
tGMAC_64KB	Memory verification of 64 KB of application firmware, using AES-128 GMAC cipher.	—	3.2	—	ms	FIRC 48MHz	—
tGMAC_1024KB	Memory verification of 1024 KB of application firmware, using AES-128 GMAC cipher.	—	46.8	—	ms	FIRC 48MHz	—
tHMAC_64KB	Memory verification of 64 KB of application firmware, using AES-128 HMAC cipher.	—	1.74	—	ms	FIRC 48MHz	—
tHMAC_1024KB	Memory verification of 1024 KB of application firmware, using AES-128 HMAC cipher.	—	22.87	—	ms	FIRC 48MHz	—
tRSA_64KB	Memory verification of 64 KB of application firmware, using RSA 2048 cipher.	—	30.47	—	ms	FIRC 48MHz	—
tRSA_1024KB	Memory verification of 1024 KB of application firmware, using RSA 2048 cipher.	—	51.6	—	ms	FIRC 48MHz	—
tECDSA_64KB	Memory verification of 64 KB of application firmware, using ECDSA 521 bits cipher.	—	38.45	—	ms	FIRC 48MHz	—
tECDSA_1024KB	Memory verification of 1024 KB of application firmware, using ECDSA 521 bits cipher.	—	59.56	—	ms	FIRC 48MHz	—
tSHA2_256_64KB	Memory verification of 64 KB of application firmware,	—	1.62	—	ms	FIRC 48MHz	—

Table continues on the next page...

Table 9. HSE firmware memory verification time examples (continued)

Symbol	Description	Min	Typ	Max	Unit	Condition	Spec Number
	using SHA2 256 bits bits cipher.						
tSHA2_256_1024KB	Memory verification of 1024 KB of application firmware, using SHA2 256 bits bits cipher.	—	22.73	—	ms	FIRC 48MHz	—
tCMAC_64KB	Memory verification of 64 KB of application firmware, using AES-128 CMAC cipher.	—	6.7	—	ms	PLL 80MHz	—
tCMAC_1024KB	Memory verification of 1024 KB of application firmware, using AES-128 CMAC cipher.	—	104.8	—	ms	PLL 80MHz	—
tGMAC_64KB	Memory verification of 64 KB of application firmware, using AES-128 GMAC cipher.	—	1.9	—	ms	PLL 80MHz	—
tGMAC_1024KB	Memory verification of 1024 KB of application firmware, using AES-128 GMAC cipher.	—	28	—	ms	PLL 80MHz	—
tHMAC_64KB	Memory verification of 64 KB of application firmware, using AES-128 HMAC cipher.	—	1.01	—	ms	PLL 80MHz	—
tHMAC_1024KB	Memory verification of 1024 KB of application firmware, using AES-128 HMAC cipher.	—	13.65	—	ms	PLL 80MHz	—
tRSA_64KB	Memory verification of 64 KB of application firmware, using RSA 2048 cipher.	—	16.72	—	ms	PLL 80MHz	—
tRSA_1024KB	Memory verification of 1024 KB of	—	34.19	—	ms	PLL 80MHz	—

Table continues on the next page...

Table 9. HSE firmware memory verification time examples (continued)

Symbol	Description	Min	Typ	Max	Unit	Condition	Spec Number
	application firmware, using RSA 2048 cipher.						
tECDSA_64KB	Memory verification of 64 KB of application firmware, using ECDSA 521 bits cipher.	—	21.58	—	ms	PLL 80MHz	—
tECDSA_1024KB	Memory verification of 1024 KB of application firmware, using ECDSA 521 bits cipher.	—	27.19	—	ms	PLL 80MHz	—
tSHA2_256_64KB	Memory verification of 64 KB of application firmware, using SHA2 256 bits cipher.	—	0.94	—	ms	PLL 80MHz	—
tSHA2_256_1024KB	Memory verification of 1024 KB of application firmware, using SHA2 256 bits cipher.	—	13.59	—	ms	PLL 80MHz	—
tCMAC_64KB	Memory verification of 64 KB of application firmware, using AES-128 CMAC cipher.	—	4.5	—	ms	PLL 120MHz	—
tCMAC_1024KB	Memory verification of 1024 KB of application firmware, using AES-128 CMAC cipher.	—	69.9	—	ms	PLL 120MHz	—
tGMAC_64KB	Memory verification of 64 KB of application firmware, using AES-128 GMAC cipher.	—	1.3	—	ms	PLL 120MHz	—
tGMAC_1024KB	Memory verification of 1024 KB of application firmware, using AES-128 GMAC cipher.	—	18.7	—	ms	PLL 120MHz	—

Table continues on the next page...

Table 9. HSE firmware memory verification time examples (continued)

Symbol	Description	Min	Typ	Max	Unit	Condition	Spec Number
tHMAC_64KB	Memory verification of 64 KB of application firmware, using AES-128 HMAC cipher.	—	0.7	—	ms	PLL 120MHz	—
tHMAC_1024KB	Memory verification of 1024 KB of application firmware, using AES-128 HMAC cipher.	—	9.12	—	ms	PLL 120MHz	—
tRSA_64KB	Memory verification of 64 KB of application firmware, using RSA 2048 cipher.	—	15.4	—	ms	PLL 120MHz	—
tRSA_1024KB	Memory verification of 1024 KB of application firmware, using RSA 2048 cipher.	—	23.8	—	ms	PLL 120MHz	—
tECDSA_64KB	Memory verification of 64 KB of application firmware, using ECDSA 521 bits cipher.	—	19.42	—	ms	PLL 120MHz	—
tECDSA_1024KB	Memory verification of 1024 KB of application firmware, using ECDSA 521 bits cipher.	—	27.81	—	ms	PLL 120MHz	—
tSHA2_256_64KB	Memory verification of 64 KB of application firmware, using SHA2 256 bits cipher.	—	0.64	—	ms	PLL 120MHz	—
tSHA2_256_1024KB	Memory verification of 1024 KB of application firmware, using SHA2 256 bits cipher.	—	9.07	—	ms	PLL 120MHz	—

6.5 Supply Monitoring

Table 10. Supply Monitoring

Symbol	Description	Min	Typ	Max	Unit	Condition	Spec Number
LVD_V15	Low Voltage Detect (LVD) on V15, deassert threshold (in FPM)	1.34	1.38	1.42	V	—	—
HVD_V15	High Voltage Detect (HVD) on V15, assert threshold (in FPM)	—	2.5	—	V	—	—
LVR_VDD_HV_A	LVR on VDD_HV_A, assert threshold (in FPM)	2.77	2.85	2.93	V	—	—
LVR_VDD_HV_A	LVR on VDD_HV_A, assert threshold (in RPM)	2.77	2.85	2.93	V	—	—
—	VDD_HV_A LVR monitor hysteresis	—	18.75	—	mV	—	—
HVD_VDD_HV_A	HVD on VDD_HV_A, assert threshold (in FPM)	5.787	5.887	5.987	V	—	—
—	VDD_HV_A HVD monitor hysteresis	—	37.5	—	mV	—	—
LVR_VDD_HV_B	LVR on VDD_HV_B, assert threshold (in FPM)	2.77	2.85	2.93	V	—	—
LVR_VDD_HV_B	LVR on VDD_HV_B, assert threshold (in RPM)	2.77	2.85	2.93	V	—	—
—	VDD_HV_B LVR monitor hysteresis	—	18.75	—	mV	—	—
HVD_VDD_HV_B	HVD on VDD_HV_B, assert threshold (in FPM)	5.787	5.887	5.987	V	—	—
—	VDD_HV_B HVD monitor hysteresis	—	37.5	—	mV	—	—
LVD_VDD_HV_A	Low Voltage Detect (LVD5A) on VDD_HV_A, assert threshold (in FPM)	4.33	4.41	4.49	V	—	—

Table continues on the next page...

Table 10. Supply Monitoring (continued)

Symbol	Description	Min	Typ	Max	Unit	Condition	Spec Number
—	VDD_HV_A LVD monitor hysteresis	—	37.5	—	mV	—	—
VPOR_VDD_HV_A	Power-On-Reset (VPOR) on VDD_HV_A, deassert threshold	0.9	1.5	2.2	V	—	—
VREF12	Bandgap reference, trimmed	1.18	1.2	1.22	V	—	—

6.6 SMPS regulator electrical specifications

The chip hardware design guidelines document lists the recommended part numbers for PMOS & Schottky diode.

Table 11. SMPS regulator electrical specifications

Symbol	Description	Min	Typ	Max	Unit	Condition	Spec Number
V15	V15 output	—	1.51	—	V	—	—
—	External coil inductance	—	4.7	—	uH	—	—
COUT_V15_SMPS	External bypass capacitor	—	20-22	—	uF	—	—
—	External Schottky diode	—	TBD	—	—	—	—
VR	Schottky diode reverse voltage	5.0	—	—	V	—	—
IF	Schottky diode forward current	1.0	—	—	A	—	—
—	External P-channel MOSFET total gate charge	—	—	10	nC	VDD_DCDC = 5V	—
—	External P-channel MOSFET threshold voltage	—	—	TBD	mV	—	—

6.7 Recommended Decoupling Capacitors

Table 12. Recommended Decoupling Capacitors

Symbol	Description	Min	Typ	Max	Unit	Condition	Spec Number
CDEC	Decoupling capacitor (one per supply pin) ^{1, 2, 3}	70	100	-	nF	—	—
CBULK	Input supply bulk capacitor ^{2, 4, 5, 6}	-	4.7	-	μF	—	—
COUT_V15_NPN	V15 (1.5V Regulator) output capacitor ^{2, 7}	-	2.2	-	μF	—	—
COUT_V11	V11 (1.1V Regulator) output capacitor (all chips, except S32K312 & S32K311) ²	-	2.2	-	μF	—	—
COUT_V11	V11 (1.1V Regulator) output capacitor (S32K312 & S32K311) ²	-	1	-	μF	—	—
COUT_V25	V25 (2.5V Regulator) output capacitor ^{2, 3}	140	220	-	nF	—	—

1. Optionally, 1 nF capacitors can be added in parallel to the decoupling capacitors.
2. All capacitors must be low ESR ceramic capacitors (for example, X7R). The minimum recommendation is after considering component aging and tolerance.
3. These capacitors must be placed as close as possible to the corresponding supply and ground pins. For BGA packages, the capacitors must be placed on the other side of the PCB to minimize the trace lengths.
4. For devices where the VDD_HV_B domain is present, if the VDD_HV_B supply is different supply from VDD_HV_A, a dedicated bulk capacitor is needed.
5. It is also possible to use higher capacitance values (for example, 10 μF) in place of the 4.7 μF capacitor.
6. These capacitors must be placed close to the source.
7. For devices where V15 is present, the V15 regulator output capacitor and the filter capacitors are required when using an NPN bipolar ballast transistor for the regulation stage. When V15 is supplied from an external regulator, these capacitance recommendations can be followed in addition to the capacitance requirements of the external voltage regulator.

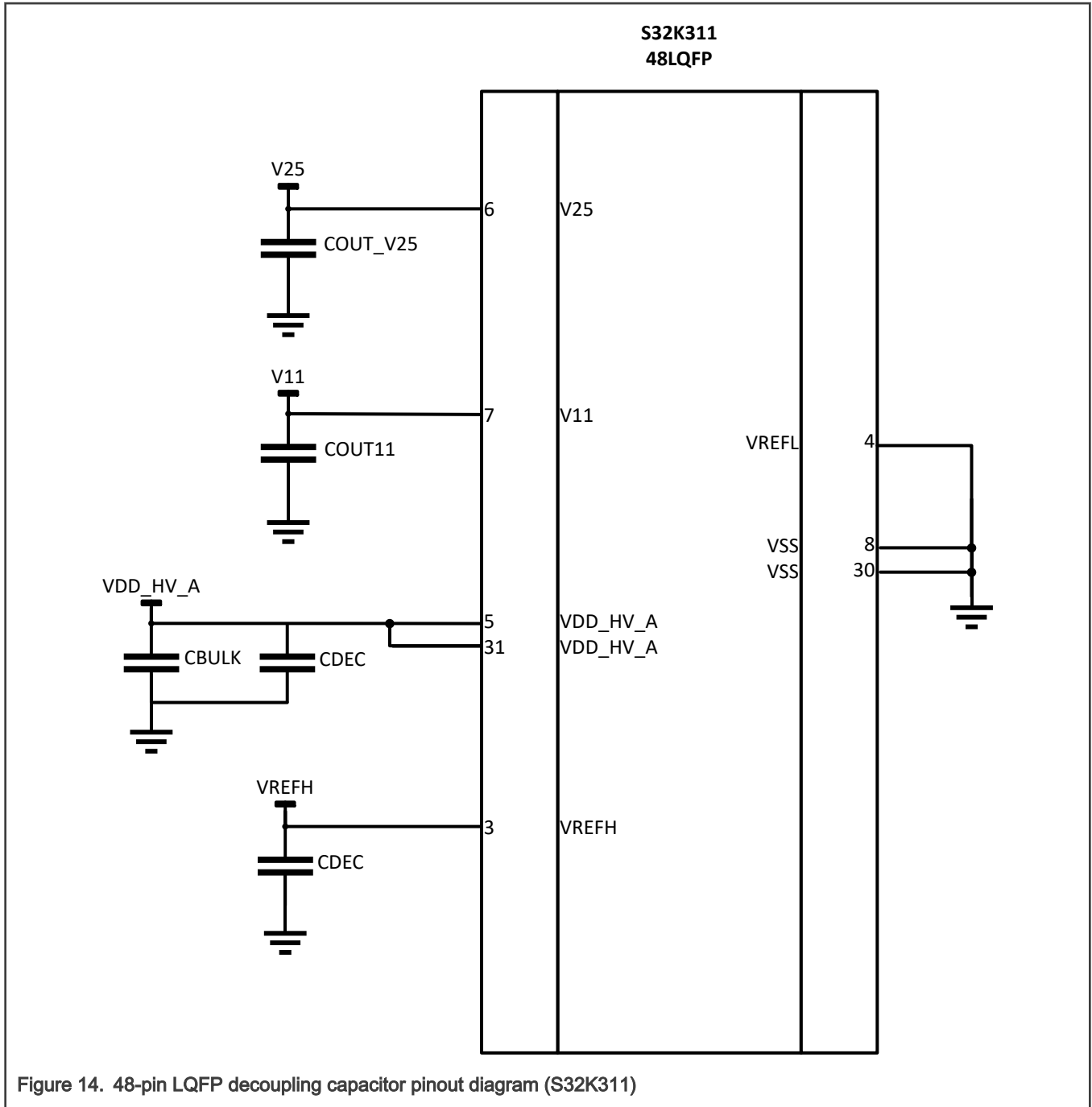

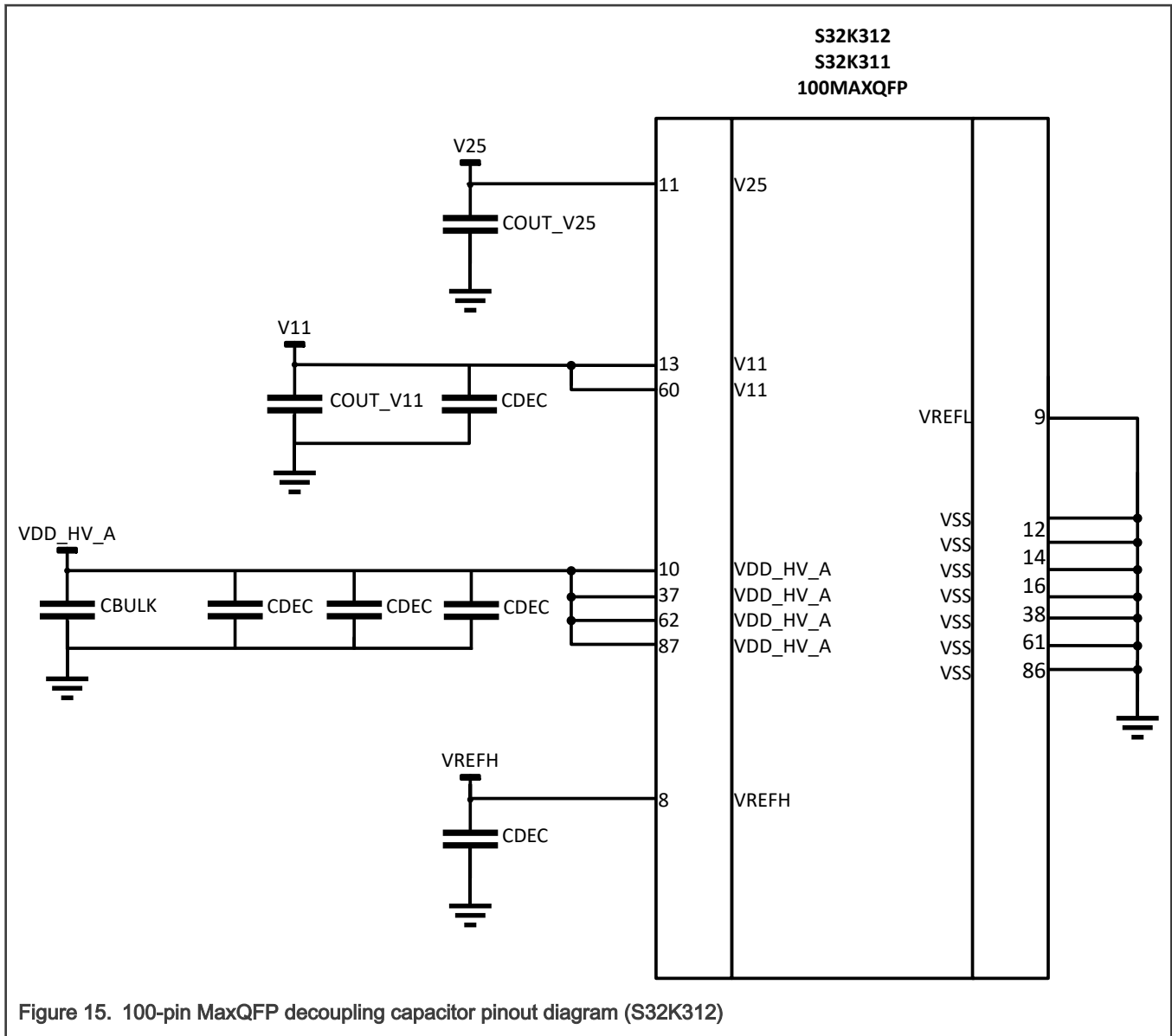

Figure 15. 100-pin MaxQFP decoupling capacitor pinout diagram (S32K312)

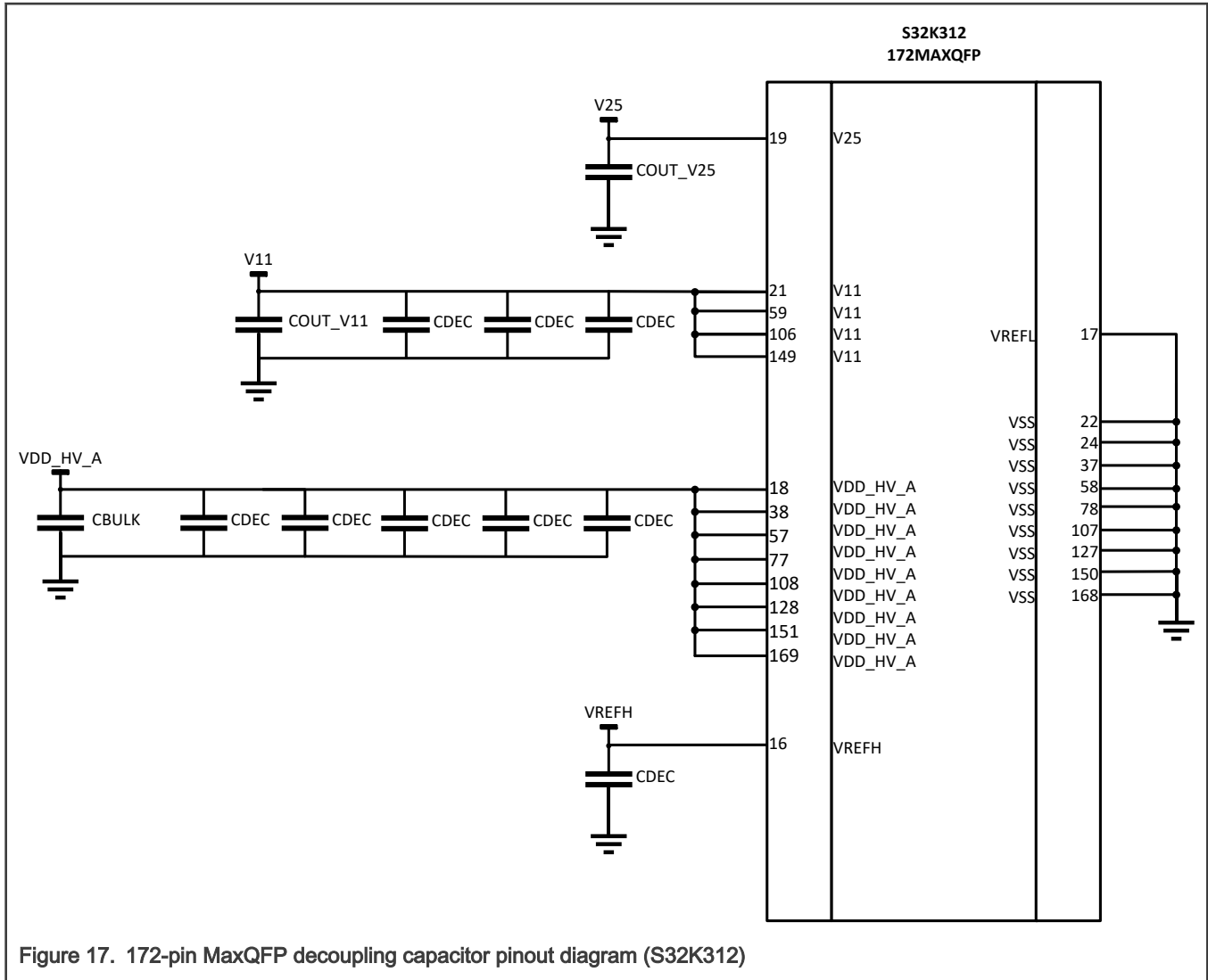

Figure 17. 172-pin MaxQFP decoupling capacitor pinout diagram (S32K312)

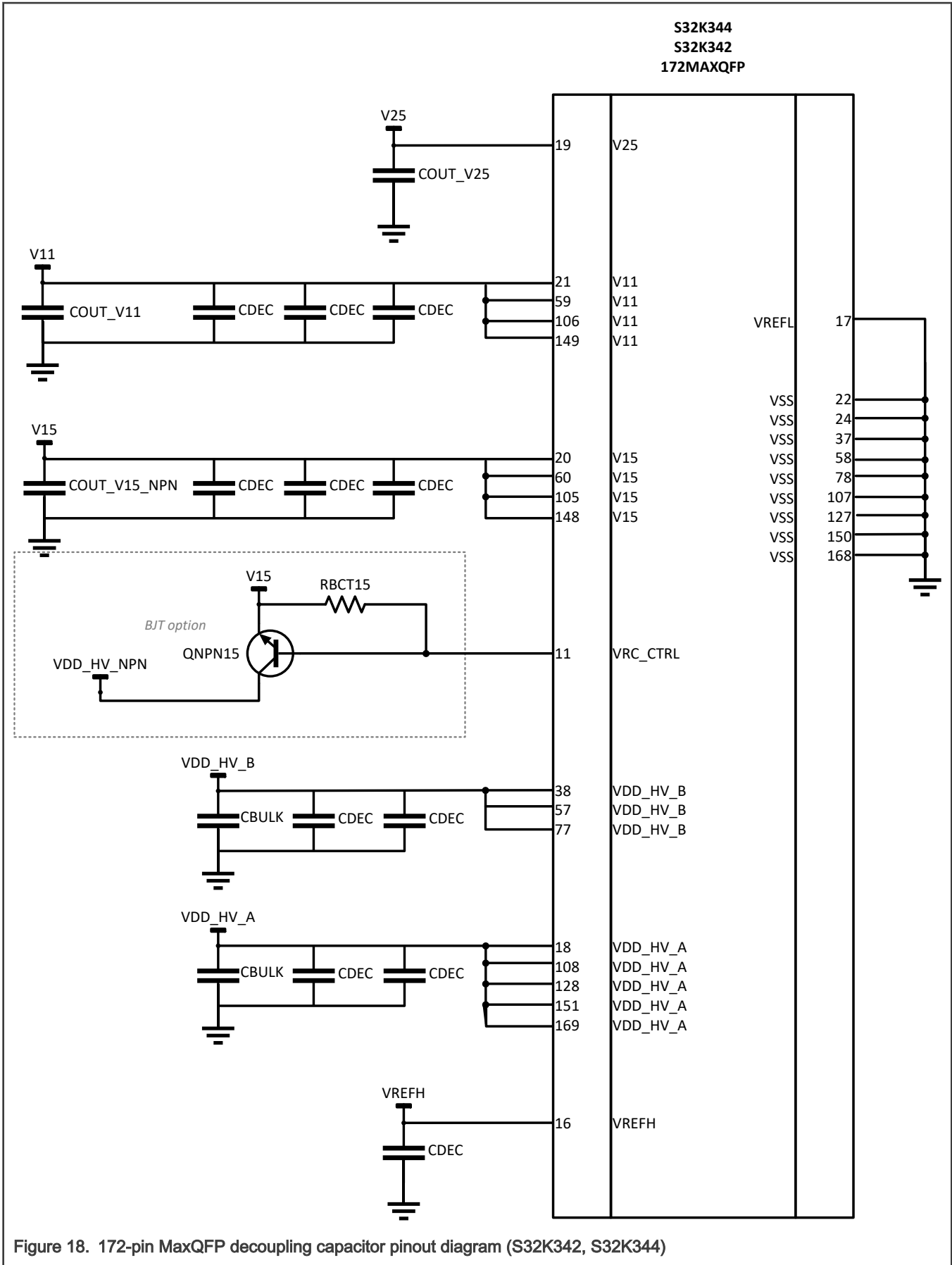

Figure 18. 172-pin MaxQFP decoupling capacitor pinout diagram (S32K342, S32K344)

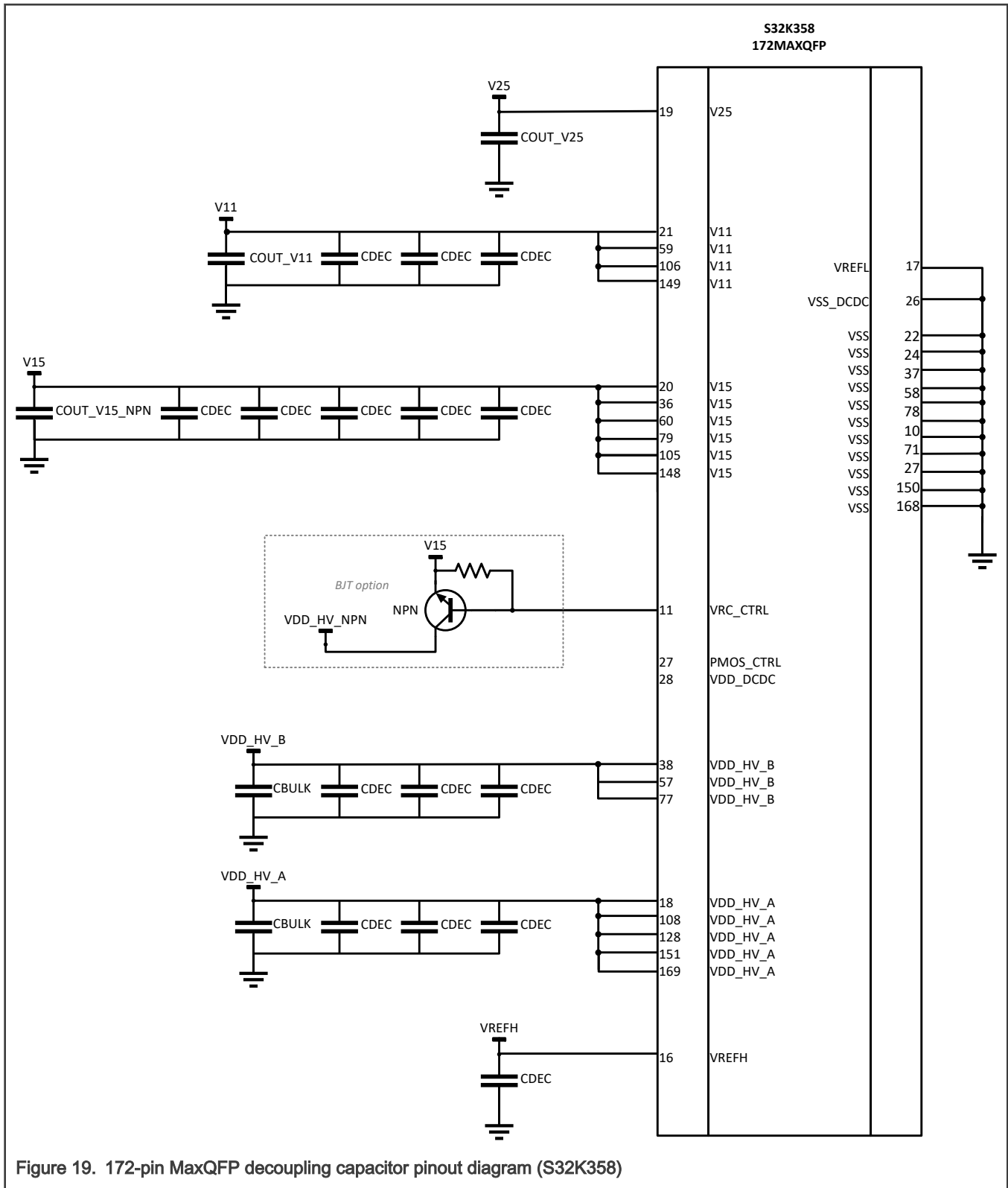

Figure 19. 172-pin MaxQFP decoupling capacitor pinout diagram (S32K358)

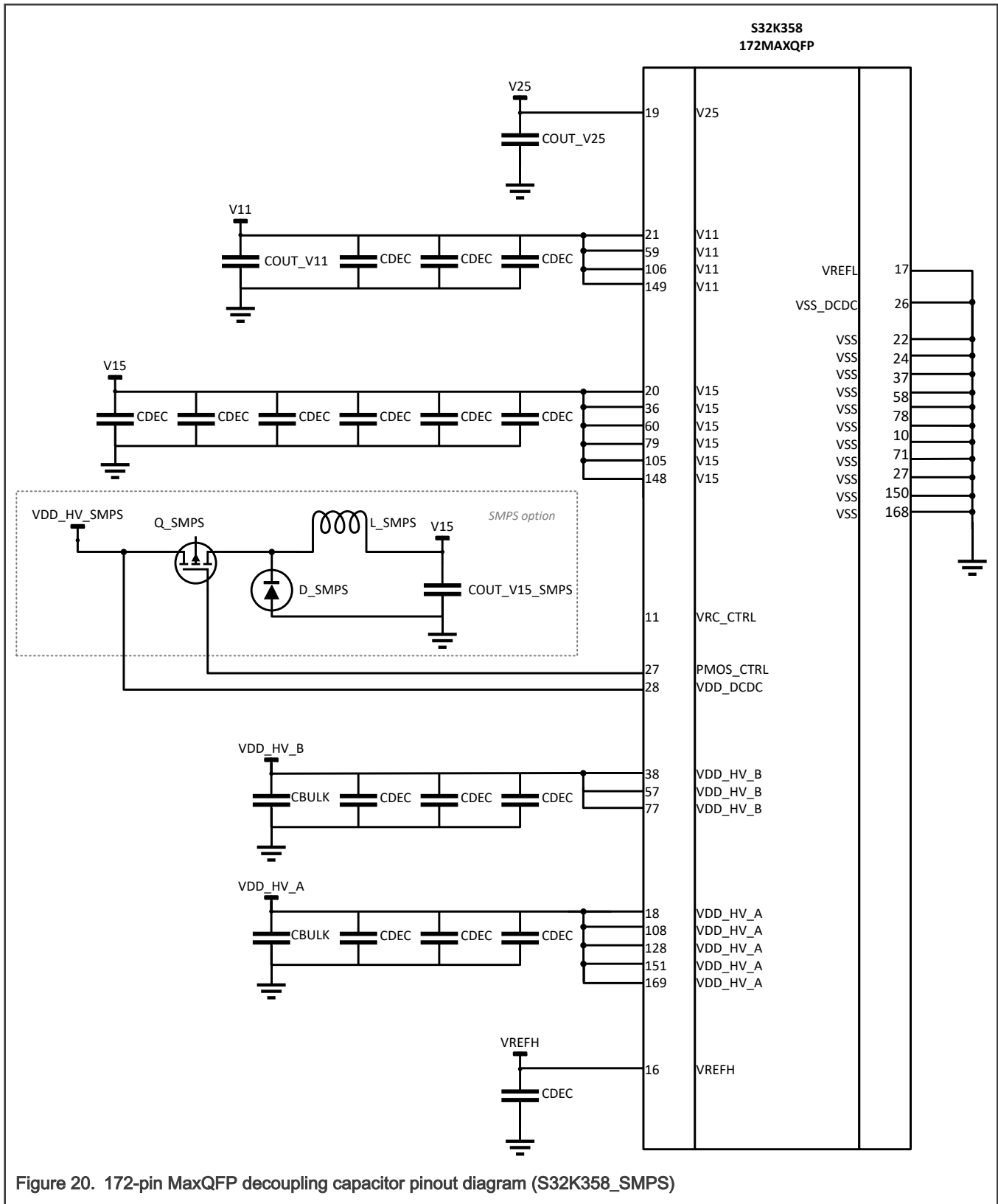

Figure 20. 172-pin MaxQFP decoupling capacitor pinout diagram (S32K358_SMPS)

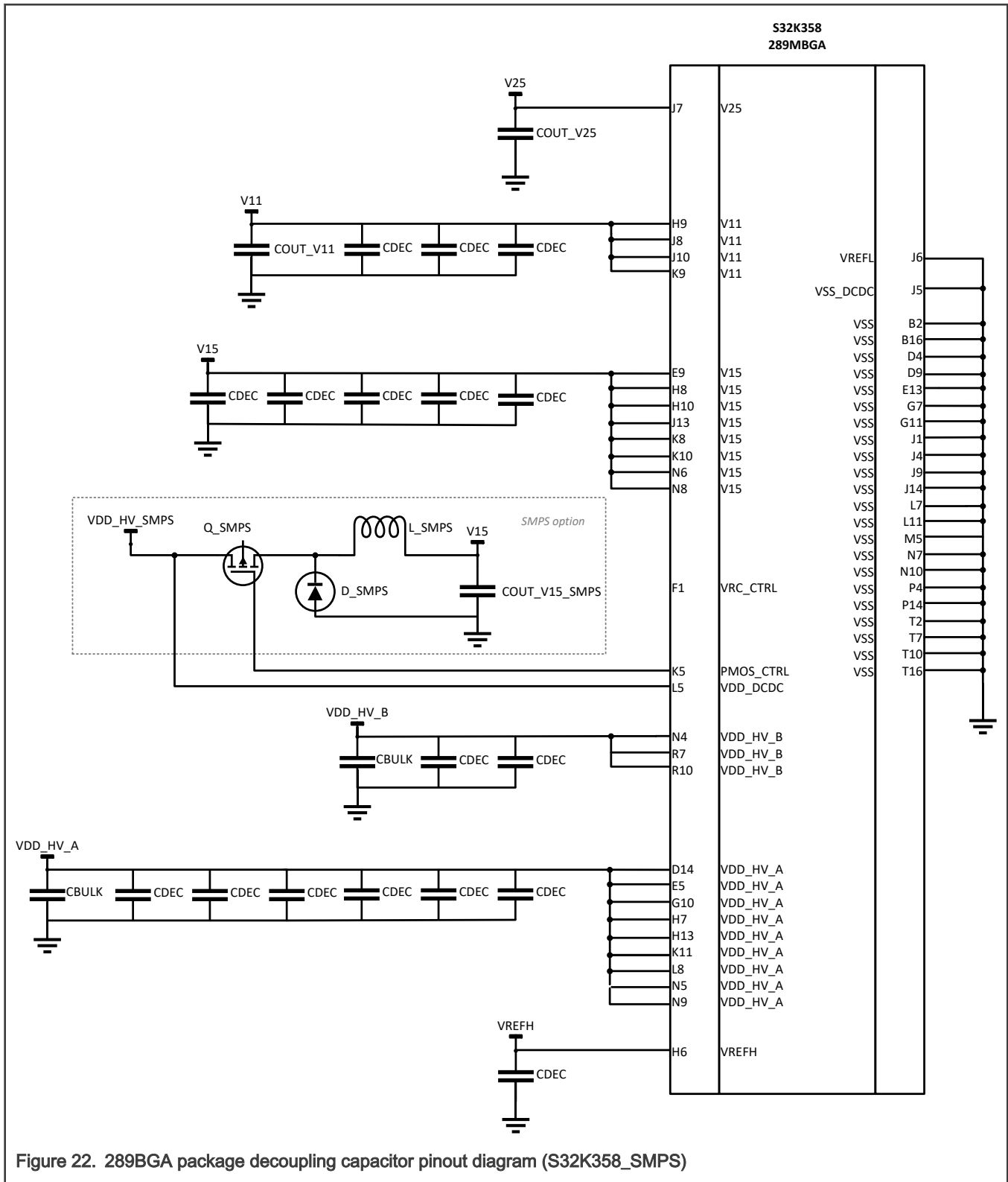

Figure 22. 289BGA package decoupling capacitor pinout diagram (S32K358_SMPS)

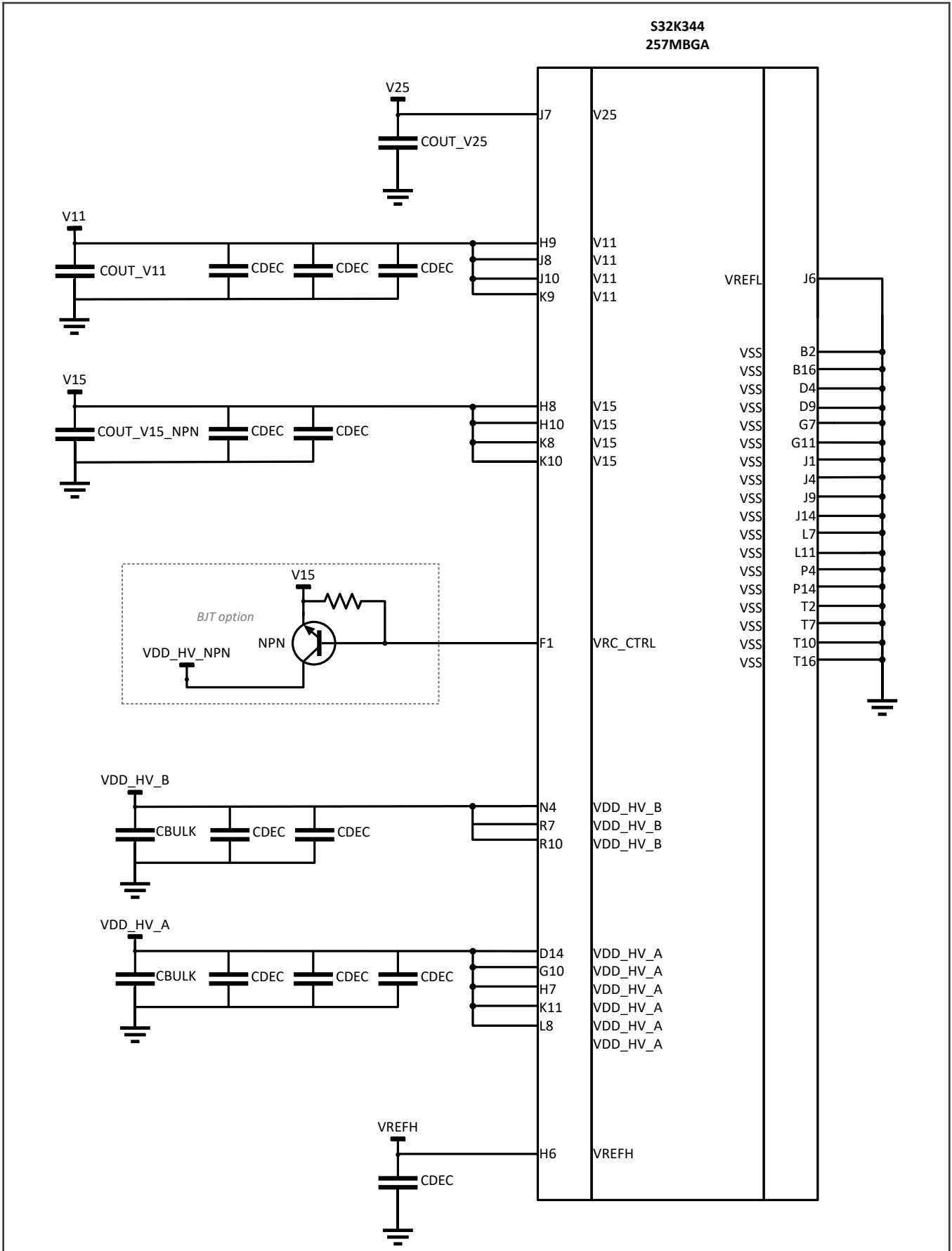

Figure 23. 257BGA package decoupling capacitor pinout diagram (S32K344)
 S32K3xx Data Sheet, Rev. 4, 04/2022

6.8 NPN Ballast Transistor Control Specification

Table 13. NPN Ballast Transistor Control Specification

Symbol	Description	Min	Typ	Max	Unit	Condition	Spec Number
V15	V15 output	—	1.51	—	V	—	—
IBCTL	IBCTL (V15 reg) source	10	—	—	mA	—	—
IBCTL	IBCTL (V15 reg) sink	—	—	-50	uA	—	—
tsettle_lm	Required setting time from activating last mile regulator to load change	2	—	—	us	—	—
VDD_HV_NPN	Input voltage supply for NPN external ballast transistor	2.5	3.3 or 5	—	V	—	—

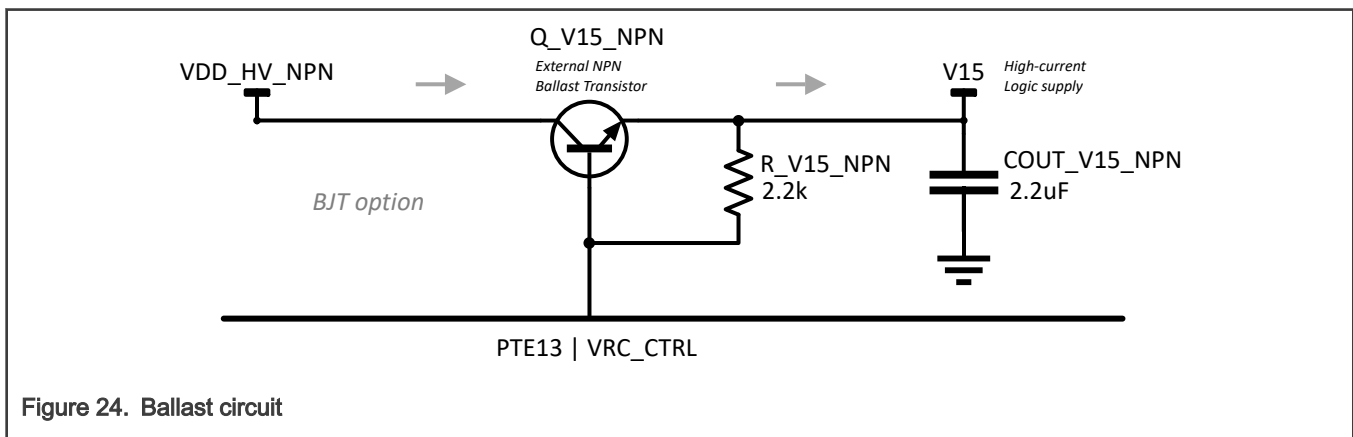

Figure 24. Ballast circuit

6.9 Supply currents

NOTE

All data in this table is preliminary and based on first samples.

Typical current numbers are indicative for typical silicon process and may vary based on the silicon distribution and user configuration. Typical conditions assumes VDD_HV_A = VREFH = 5 V, VDD_HV_B = 5V (if the VDD_HV_B domain present in the device), temperature = 25 °C, and typical silicon process unless otherwise stated. In STANDBY configuration, no current flows through the V15 supply.

Table 14. STANDBY mode supply currents

Chip	Ambient Temperature (°C)	STANDBY ¹			
		VDD_HV_A ²			VDD_HV_B ²
		All clocks & peripherals OFF (μ A)	SIRC ON (μ A)	FIRC ON (24 MHz) (mA)	All Config. (μ A)
S32K358, S32K348, S32K338, S32K328	25, typ ³	75	78	0.98	TBD
	25, max ⁴	TBD	TBD	TBD	TBD
	85, typ ³	TBD	TBD	TBD	TBD
	85, max ⁴	TBD	TBD	TBD	TBD
	105, typ ³	TBD	TBD	TBD	TBD
	105, max ⁴	TBD	TBD	TBD	TBD
	125, typ ³	TBD	TBD	TBD	TBD
	125, max ⁴	TBD	TBD	TBD	TBD
S32K344, S32K324, S32K314	25, typ ³	50	52	0.91	1.8
	25, max ⁴	153	153	1.05	3.8
	85, typ ³	315	316	1.18	6.1
	85, max ⁴	900	910	1.78	15.4

Table continues on the next page...

Table 14. STANDBY mode supply currents (continued)

	105, typ ³	498	530	1.40	8.5
	105, max ⁴	1672	1682	2.55	26.2
	125, typ ³	932	998	1.88	18.5
	125, max ⁴	2638	2650	3.5	47.3
S32K342, S32K322, S32K341	25, typ ³	50	52	0.91	1.8
	25, max ⁴	TBD	TBD	TBD	TBD
	85, typ ³	TBD	TBD	TBD	TBD
	85, max ⁴	TBD	TBD	TBD	TBD
	105, typ ³	TBD	TBD	TBD	TBD
	105, max ⁴	TBD	TBD	TBD	-
	125, typ ³	TBD	TBD	TBD	TBD
	125, max ⁴	TBD	TBD	5.5	-
S32K312	25, typ ³	40	41	0.887	NA
	25, max ⁴	79	80	1.031	
	85, typ ³	178	178	1.027	
	85, max ⁴	496	497	1.422	
	105, typ ³	350	346	1.197	
	105, max ⁴	994	997	1.924	
	125, typ ³	620	611	1.457	
	125, max ⁴	1788	1792	2.761	

Table continues on the next page...

Table 14. STANDBY mode supply currents (continued)

S32K311	25, typ ³	46	48	0.91	NA
	25, max ⁴	TBD	TBD	TBD	
	85, typ ³	TBD	TBD	TBD	
	85, max ⁴	TBD	TBD	TBD	
	105, typ ³	TBD	TBD	TBD	
	105, max ⁴	TBD	TBD	TBD	
	125, typ ³	TBD	TBD	TBD	
	125, max ⁴	TBD	TBD	TBD	

1. See the configurations in [Table 18](#).
2. IO load current is not included. The actual current requirements for IOs will depend on the I/O configuration in the application.
3. “typ” is indicative of the average current numbers at the nominal internally regulated V11 supply voltage, VDD_HV_A = 5.0V, VDD_HV_B = 5.0V, for the typical silicon process..
4. “max” is indicative of the maximum current numbers at the maximum internally regulated V11 supply voltage (1.16 V), VDD_HV_A = 5.5V, VDD_HV_B = 5.5V, for the fast silicon process.

NOTE

All data in this table is preliminary and based on first samples.

Typical current numbers are indicative for typical silicon process and may vary based on the silicon distribution and user configuration. Typical conditions assumes $VDD_HV_A = VREFH = 5\text{ V}$, $VDD_HV_B = 5\text{ V}$ (if the VDD_HV_B domain present in the device), temperature = $25\text{ }^{\circ}\text{C}$, and typical silicon process unless otherwise stated.

Table 15. Low speed RUN mode supply currents

Chip	Ambient Temperature (°C)	Low Speed RUN Mode (mA) ¹												
		BOOT Mode ² [Clock Option C] FIRC @ 24 MHz [Last Mile Disabled]		BOOT Mode ² [Clock Option C] FIRC @ 24 MHz [Last Mile Enabled]		Low Speed RUN ² [Clock Option E] FIRC @3 MHz [Last Mile Disabled]		Low Speed RUN ² [Clock Option E] FIRC @3 MHz [Last Mile Enabled]		Low Speed RUN ² [Clock Option D] FIRC @48 MHz [Last Mile Disabled]		Low Speed RUN ² [Clock Option D] FIRC @48 MHz [Last Mile Enabled]		All Config ²
		VDD_HV_A ^{3,4}	V ₁₅ ⁵	VDD_HV_A ^{3,4}	V ₁₅ ⁵	VDD_HV_A ^{3,4}	V ₁₅ ⁵	VDD_HV_A ^{3,4}	V ₁₅ ⁵	VDD_HV_A ^{3,4}	V ₁₅ ⁵	VDD_HV_A ^{3,4}	V ₁₅ ⁵	VDD_H V_B ³
S32K358, S32K348, S32K338, S32K328	25, typ ⁶	NA	5	25	NA	5	6	NA	5	55	TBD			
	25, max ⁷		TBD	TBD		TBD	TBD		TBD	TBD				
	85, typ ⁶		TBD	TBD		TBD	TBD		TBD	TBD				
	85, max ⁷		TBD	TBD		TBD	TBD		TBD	TBD				
	105, typ ⁶		TBD	TBD		TBD	TBD		TBD	TBD				
	105, max ⁷		TBD	TBD		TBD	TBD		TBD	TBD				
	125, typ ⁶		TBD	TBD		TBD	TBD		TBD	TBD				
	125, max ^{7, 8}		TBD	TBD		TBD	TBD		TBD	TBD				
S32K344, S32K324, S32K314	25, typ ⁶	20.5	-	2.8	17.9	6.4	-	2.8	4.5	37.2	-	2.9	34	0.6
	25, max ⁷	29.4	-	3.2	27.2	14.8	-	3.1	12.6	46.8	-	3.2	46.6	0.8
	85, typ ⁶	34.2	-	2.9	31.2	19.7	-	2.9	17.5	50.4	-	2.9	47.3	0.5

Table continues on the next page...

Table 15. Low speed RUN mode supply currents (continued)

	85, max ⁷	71.6	-	3.5	68.7	56.2	-	3.4	54	89.1	-	3.5	86.2	0.7
	105, typ ⁶	46.1	-	2.9	43.1	31.7	-	2.9	29.3	62.2	-	2.9	59.2	0.5
	105, max ⁷	114	-	3.7	111	99.1	-	3.6	96.1	131	-	3.9	128	0.7
	125, typ ⁶	69.9	-	3.0	66.8	55.8	-	3.0	53.1	86	-	3.1	83	0.5
	125, max ^{7, 8}	161	-	4.2	159	148	-	4.1	145	178	-	4.3	176	0.7
S32K342, S32K322, S32K341	25, typ ⁶	20	-	2.8	17.9	6.4	-	2.8	4.5	37.2	-	2.9	34	0.6
	25, max ⁷	TBD	TBD	TBD	TBD	TBD	TBD	TBD	TBD	TBD	TBD	TBD	TBD	0.7
	85, typ ⁶	TBD	TBD	TBD	TBD	TBD	TBD	TBD	TBD	TBD	TBD	TBD	TBD	TBD
	85, max ⁷	TBD	TBD	TBD	TBD	TBD	TBD	TBD	TBD	TBD	TBD	TBD	TBD	TBD
	105, typ ⁶	TBD	TBD	TBD	TBD	TBD	TBD	TBD	TBD	TBD	TBD	TBD	TBD	0.5
	105, max ⁷	TBD	TBD	TBD	TBD	TBD	TBD	TBD	TBD	TBD	TBD	TBD	TBD	0.6
	125, typ ⁶	TBD	TBD	TBD	TBD	TBD	TBD	TBD	TBD	TBD	TBD	TBD	TBD	0.5
	125, max ^{7, 8}	TBD	TBD	TBD	TBD	TBD	TBD	TBD	TBD	TBD	TBD	TBD	TBD	0.6
S32K312	25, typ ⁶	15	NA	NA	5	NA	NA	26	NA	NA	NA			
	25, max ⁷	20			10			32						
	85, typ ⁶	20			10			31						
	85, max ⁷	35.2			24.6			46.4						
	105, typ ⁶	26.1			16.2			37						
	105, max ⁷	52.9			42.6			64.2						
	125, typ ⁶	35.3			25.3			46.4						

Table continues on the next page...

Table 15. Low speed RUN mode supply currents (continued)

	125, max ^{7, 8, 9}	79.8			66.9			90.1			
S32K311	25, typ ⁶	15	NA	NA	6	NA	NA	30	NA	NA	NA
	25, max ⁷	TBD			TBD			TBD			
	85, typ ⁶	TBD			TBD			TBD			
	85, max ⁷	TBD			TBD			TBD			
	105, typ ⁶	TBD			TBD			TBD			
	105, max ⁷	TBD			TBD			TBD			
	125, typ ⁶	TBD			TBD			TBD			
	125, max ^{7, 8, 9}	TBD			TBD			TBD			

1. Current numbers are for reduced configuration and may vary based on user configuration and silicon process variation.
2. See the example configurations in [Table 18](#).
3. IO load current is not included. The actual current requirements for IOs will depend on the I/O configuration in the application.
4. RUN IDD @ VDD_HV_A includes Flash memory read current from the V25 voltage rail.
5. RUN IDD @ V15 includes Flash memory read current from the V11 voltage rail
6. "typ" is indicative of the average current numbers at the nominal internally regulated V11 supply voltage, VDD_HV_A = 5.0V, VDD_HV_B = 5.0V, V15 = 1.5V, for the typical silicon process.
7. "max" is indicative of the maximum current numbers at the maximum internally regulated V11 supply voltage (1.16 V), VDD_HV_A = 5.5V, VDD_HV_B = 5.5V, V15 = 1.65V, for the fast silicon process.
8. For the maximum allowable RUN current in an application, the junction temperature must be kept below the maximum specification, $T_J < 150^{\circ}\text{C}$, to avoid self-heating.
9. If the total power dissipation would cause the junction temperature to be exceeded when VDD_HV_A is at 5V, then VDD_HV_A should be limited to operate at 3.3V.

NOTE

All data in this table is preliminary and based on first samples.

Typical current numbers are indicative for typical silicon process and may vary based on the silicon distribution and user configuration. Typical conditions assumes $VDD_HV_A = VREFH = 5\text{ V}$, $VDD_HV_B = 5\text{ V}$ (if the VDD_HV_B domain present in the device), temperature = $25\text{ }^{\circ}\text{C}$ and typical silicon process unless otherwise stated.

Table 16. RUN mode supply currents (peripherals disabled)

Chip	Ambient Temperature (°C)	RUN Mode (mA) ¹												
		Min. Config. ² Single Core @80 MHz [Clock Option F]		Min. Config. ² Single Core @120 MHz [Clock Option B]		Min. Config. ² Single Core @160 MHz [Clock Option A]		Min. Config. ² Dual Core @80 MHz [Clock Option F]		Min. Config. ² Dual Core @120 MHz [Clock Option B]		Min. Config. ² Dual Core @160 MHz [Clock Option A]		All. Config. ²
		VDD_HV_A ^{3,4}	V15 ⁵	VDD_HV_A ^{3,4}	V15 ⁵	VDD_HV_A ^{3,4}	V15 ⁵	VDD_HV_A ^{3,4}	V15 ⁵	VDD_HV_A ^{3,4}	V15 ⁵	VDD_HV_A ^{3,4}	V15 ⁵	VDD_H V_B ³
S32K358, S32K348, S32K338, S32K328	25, typ ⁶	TBD	TBD	TBD	TBD	TBD	TBD	TBD	TBD	TBD	TBD	TBD	TBD	TBD
	25, max ⁷	TBD	TBD	TBD	TBD	TBD	TBD	TBD	TBD	TBD	TBD	TBD	TBD	TBD
	85, typ ⁶	TBD	TBD	TBD	TBD	TBD	TBD	TBD	TBD	TBD	TBD	TBD	TBD	TBD
	85, max ⁷	TBD	TBD	TBD	TBD	TBD	TBD	TBD	TBD	TBD	TBD	TBD	TBD	TBD
	105, typ ⁶	TBD	TBD	TBD	TBD	TBD	TBD	TBD	TBD	TBD	TBD	TBD	TBD	TBD
	105, max ⁷	TBD	TBD	TBD	TBD	TBD	TBD	TBD	TBD	TBD	TBD	TBD	TBD	TBD
	125, typ ⁶	TBD	TBD	TBD	TBD	TBD	TBD	TBD	TBD	TBD	TBD	TBD	TBD	TBD
	125, max ^{7,8}	TBD	TBD	TBD	TBD	TBD	TBD	TBD	TBD	TBD	TBD	TBD	TBD	TBD
S32K344, S32K324, S32K314	25, typ ⁶	2.9	51.3	2.9	54.8	2.9	69.6	3.1	62.7	3.1	75.1	3.1	97.5	0.6
	25, max ⁷	3.3	60.2	3.3	64.5	3.3	80.4	3.4	73.3	3.5	86.8	3.5	110	0.7
	85, typ ⁶	3.0	64.5	3.0	68.1	3.0	83.1	3.1	76.2	3.2	89	3.2	111	0.4
	85, max ⁷	3.6	104	3.6	108	3.7	124	3.8	117	3.9	131	3.8	155	0.6

Table continues on the next page...

Table 16. RUN mode supply currents (peripherals disabled) (continued)

	105, typ ⁶	3.0	75.4	3.0	79	3.0	93.9	3.2	87.3	3.2	100	3.2	122.6	0.5
	105, max ⁷	3.8	145	3.8	149	3.8	166	3.9	159	4.0	173	4.0	197	0.6
	125, typ ⁶	3.1	97.4	3.1	101.2	3.1	116.4	3.3	110	3.3	122.9	3.3	145.7	0.5
	125, max ^{7, 8}	4.2	191	4.1	196	4.2	212	4.3	206	4.3	220	4.3	245	0.6
S32K342, S32K322, S32K341	25, typ ⁶	2.9	51	2.9	54	2.9	69	3.1	62	3.1	74	3.1	97	0.6
	25, max ⁷	TBD	TBD	TBD	TBD	TBD	TBD	TBD	TBD	TBD	TBD	TBD	TBD	0.7
	85, typ ⁶	TBD	TBD	TBD	TBD	TBD	TBD	TBD	TBD	TBD	TBD	TBD	TBD	TBD
	85, max ⁷	TBD	TBD	TBD	TBD	TBD	TBD	TBD	TBD	TBD	TBD	TBD	TBD	TBD
	105, typ ⁶	TBD	TBD	TBD	TBD	TBD	TBD	TBD	TBD	TBD	TBD	TBD	TBD	TBD
	105, max ⁷	TBD	TBD	TBD	TBD	TBD	TBD	TBD	TBD	TBD	TBD	TBD	TBD	TBD
	125, typ ⁶	TBD	TBD	TBD	TBD	TBD	TBD	TBD	TBD	TBD	TBD	TBD	TBD	0.5
	125, max ^{7, 8}	TBD	TBD	TBD	TBD	TBD	TBD	TBD	TBD	TBD	TBD	TBD	TBD	0.6
S32K312	25, typ ⁶	37	NA	37	NA	NA		NA						NA
	25, max ⁷	44		46										
	85, typ ⁶	42		43										
	85, max ⁷	58.5		59.7										
	105, typ ⁶	48.1		48.7										
	105, max ⁷	76.4		77.8										
	125, typ ⁶	56.5		57										
	125, max ^{7, 8, 9}	98.7		99.9										

Table continues on the next page...

Table 16. RUN mode supply currents (peripherals disabled) (continued)

S32K311	25, typ ⁶	60	NA	65	NA	NA	NA	NA
	25, max ⁷	TBD		TBD				
	85, typ ⁶	TBD		TBD				
	85, max ⁷	TBD		TBD				
	105, typ ⁶	TBD		TBD				
	105, max ⁷	TBD		TBD				
	125, typ ⁶	TBD		TBD				
	125, max ^{7, 8, 9}	120		125				

1. Current numbers are for reduced configuration and may vary based on user configuration and silicon process variation.
2. See the configurations in [Table 19](#).
3. IO load current is not included. The actual current requirements for IOs will depend on the I/O configuration in the application.
4. RUN IDD @ VDD_HV_A includes Flash memory read current from the V25 voltage rail.
5. RUN IDD @ V15 includes Flash memory read current from the V11 voltage rail.
6. "typ" is indicative of the average current numbers at the nominal internally regulated V11 supply voltage, VDD_HV_A = 5.0V, VDD_HV_B = 5.0V, V15 = 1.5V, for the typical silicon process.
7. "max" is indicative of the maximum current numbers at the maximum internally regulated V11 supply voltage (1.16 V), VDD_HV_A = 5.5V, VDD_HV_B = 5.5V, V15 = 1.65V, for the fast silicon process.
8. For the maximum allowable RUN current in an application, the junction temperature must be kept below the maximum specification, $T_J < 150^{\circ}\text{C}$, to avoid self-heating.
9. If the total power dissipation would cause the junction temperature to be exceeded when VDD_HV_A is at 5V, then VDD_HV_A should be limited to operate at 3.3V.

NOTE

The data in this table is preliminary and based on first samples.

Typical current numbers are indicative for typical silicon process and may vary based on the silicon distribution and user configuration. Typical conditions assumes $VDD_HV_A = VREFH = 5\text{ V}$, $VDD_HV_B = 5\text{ V}$ (if the VDD_HV_B domain present in the device), temperature = $25\text{ }^{\circ}\text{C}$ and typical silicon process unless otherwise stated.

Table 17. Example RUN mode configuration supply currents

Chip	Ambient Temperature (°C)	RUN Mode (mA) ¹												
		Config. 1 ² Dual Core @160 MHz		Config. 2 ² Single Core @160 MHz		Config. 3 ² Dual Core @120 MHz		Config. 4 ² Single Core @120 MHz		Config. 5 ² Single Core @80 MHz		Config. 6 ² Triple Core @240 MHz		Config. 1-6 ²
		VDD_HV_A ^{3,4}	V15 ⁵	VDD_HV_A ^{3,4}	V15 ⁵	VDD_HV_A ^{3,4}	V15 ⁵	VDD_HV_A ^{3,4}	V15 ⁵	VDD_HV_A ^{3,4}	V15 ⁵	VDD_H V_A ^{3,4}	V15 ⁵	VDD_H V_B ³
S32K358, S32K348, S32K338, S32K328	25, typ ⁶	TBD	TBD	TBD	TBD	TBD	TBD	TBD	TBD	TBD	TBD	TBD	TBD	TBD
	25, max ⁷	TBD	TBD	TBD	TBD	TBD	TBD	TBD	TBD	TBD	TBD	TBD	TBD	TBD
	85, typ ⁶	TBD	TBD	TBD	TBD	TBD	TBD	TBD	TBD	TBD	TBD	TBD	TBD	TBD
	85, max ⁷	TBD	TBD	TBD	TBD	TBD	TBD	TBD	TBD	TBD	TBD	TBD	TBD	TBD
	105, typ ⁶	TBD	TBD	TBD	TBD	TBD	TBD	TBD	TBD	TBD	TBD	TBD	TBD	TBD
	105, max ⁷	TBD	TBD	TBD	TBD	TBD	TBD	TBD	TBD	TBD	TBD	TBD	TBD	TBD
	125, typ ⁶	TBD	TBD	TBD	TBD	TBD	TBD	TBD	TBD	TBD	TBD	TBD	TBD	TBD
	125, max ^{7, 8}	TBD	TBD	TBD	TBD	TBD	TBD	TBD	TBD	TBD	TBD	TBD	TBD	TBD
S32K344, S32K324, S32K314	25, typ ⁶	2.9	119	3.0	102	3.1	106	3.0	80	2.9	68	NA		0.6
	25, max ⁷	3.3	133	3.3	115	3.5	119	3.4	92	3.4	79			0.7
	85, typ ⁶	3.0	134	3.0	116	3.2	120	3.1	94	3.0	81.8			0.4
	85, max ⁷	3.6	180	3.7	160	3.9	165	3.8	137	3.6	123			0.6
	105, typ ⁶	3.0	145	3.1	128	3.2	132	3.1	105	3.0	93			0.5

Table continues on the next page...

Table 17. Example RUN mode configuration supply currents (continued)

	105, max ⁷	3.8	222	3.9	203	4.0	208	3.9	179	3.6	165		0.6
	125, typ ⁶	3.1	169	3.2	151	3.3	155	3.2	128	3.2	116		0.5
	125, max ^{7,8}	4.3	271	4.3	250	4.5	256	4.4	226	4.2	213		0.6
S32K342, S32K322, S32K341	25, typ ⁶	2.9	115	3.0	99	3.1	99	2.9	78	2.9	66	NA	0.6
	25, max ⁷	3.3	128	3.3	110	3.5	112	3.3	90	3.3	77		0.7
	85, typ ⁶	TBD	TBD	TBD	TBD	TBD	TBD	TBD	TBD	TBD	TBD		TBD
	85, max ⁷	TBD	TBD	TBD	TBD	TBD	TBD	TBD	TBD	TBD	TBD		TBD
	105, typ ⁶	3.0	140	3.1	121	3.2	126	3.0	103	3.0	90		0.5
	105, max ⁷	3.8	240	3.9	220	4.0	225	3.8	198	3.8	184		0.6
	125, typ ⁶	3.1	164	3.2	145	3.3	150	3.1	125	3.1	110		0.5
	125, max ^{7,8}	4.3	330	4.5	304	4.7	304	4.3	280	4.3	265		0.6
S32K312	25, typ ⁶	NA		NA		NA		54	NA	44	NA	NA	NA
	25, max ⁷							62		53			
	85, typ ⁶							60		49			
	85, max ⁷							76.4		66.3			
	105, typ ⁶							65.8		55			
	105, max ⁷							94.4		84.4			
	125, typ ⁶							78.6		64.7			
	125, max ^{7,8,9}							120.7		110.5			
S32K311	25, typ ⁶	NA		NA		NA		80	NA	70	NA	NA	NA

Table continues on the next page...

Table 17. Example RUN mode configuration supply currents (continued)

25, max ⁷				92		80		
85, typ ⁶				TBD		TBD		
85, max ⁷				TBD		TBD		
105, typ ⁶				TBD		TBD		
105, max ⁷				TBD		TBD		
125, typ ⁶				TBD		TBD		
125, max ^{7, 8, 9}				140		130		

1. Current numbers are for reduced configuration and may vary based on user configuration and silicon process variation.
2. See the configurations in [Table 19](#).
3. IO current is not included. The actual current requirements for IOs will depend on the I/O configuration in the application.
4. RUN IDD @ VDD_HV_A includes Flash memory read current from the V25 voltage rail.
5. RUN IDD @ V15 includes Flash memory read current from the V11 voltage rail.
6. "typ" is indicative of the average current numbers at the nominal internally regulated V11 supply voltage, VDD_HV_A = 5.0V, VDD_HV_B = 5.0V, V15 = 1.5V, for the typical silicon process.
7. "max" is indicative of the maximum current numbers at the maximum internally regulated V11 supply voltage (1.16 V), VDD_HV_A = 5.5V, VDD_HV_B = 5.5V, V15 = 1.65V, for the fast silicon process.
8. For the maximum allowable RUN current in an application, the junction temperature must be kept below the maximum specification, $T_J < 150^{\circ}\text{C}$, to avoid self-heating.
9. If the total power dissipation would cause the junction temperature to be exceeded when VDD_HV_A is at 5V, then VDD_HV_A should be limited to operate at 3.3V.

6.10 Operating mode

Table 18. STANDBY and low speed RUN configuration options

MODULE	STANDBY All OFF	STANDBY SIRC ON	STANDBY FIRC ON	BOOT Mode (OptionC ¹ , FIRC @24 MHz)	Low Speed RUN (OptionE ¹ , FIRC @ 3MHz)	FIRC Mode (OptionD ¹ , FIRC @48 MHz)
Core M7_0	OFF	OFF	OFF	24 MHz	3 MHz	48 MHz
Core M7_1	OFF	OFF	OFF	24 MHz	3 MHz	48 MHz
HSE_B	OFF	OFF	OFF	24 MHz	3 MHz	48 MHz
FIRC	OFF	OFF	24 MHz	24 MHz	3 MHz	48 MHz
FXOSC	OFF	OFF	OFF	OFF	OFF	OFF
SIRC	OFF	ON	OFF	ON	ON	ON
PLL	OFF	OFF	OFF	OFF	OFF	OFF
Flash	OFF	OFF	OFF	ON	ON	ON
eDMA	OFF	OFF	OFF	ON	ON	ON
FlexCAN	All OFF	All OFF	All OFF	All OFF	All OFF	All OFF
LPUART	All OFF	All OFF	All OFF	All OFF	All OFF	All OFF
LPSPi	All OFF	All OFF	All OFF	All OFF	All OFF	All OFF
LPI2C	All OFF	All OFF	All OFF	All OFF	All OFF	All OFF
EMAC	OFF	OFF	OFF	OFF	OFF	OFF
eMIOS	All OFF	All OFF	All OFF	All OFF	All OFF	All OFF
SAR_ADC	All OFF	All OFF	All OFF	All OFF	All OFF	All OFF
LPCMP	All OFF	All OFF	All OFF	All OFF	All OFF	All OFF

1. See clocking use case examples in the Clocking chapter of the S32K3xx Reference Manual.

Table 19. RUN mode configuration options

MODULE	Min. Config. (OptionF ¹) , PLL@80 MHz	Min. Config. (OptionB ¹) , PLL@120 MHz	Min. Config. (OptionA ¹) , PLL@160 MHz	Config. 1 Dual Core @160MHz	Config. 2 Single Core @160MHz	Config. 3 Dual Core @120MHz	Config. 4 Single Core @120MHz	Config. 5 Single Core @80MHz	Config. 6 Triple Core @240MHz
Core M7_0	80 MHz	120 MHz	160 MHz	160 MHz	160 MHz	120 MHz	120 MHz	80 MHz	240 MHz

Table continues on the next page...

Table 19. RUN mode configuration options (continued)

Core M7_1	80 MHz	120 MHz	160 MHz	160 MHz	-	120 MHz	-	-	240 MHz
Core M7_2	-	-	-	-	-	-	-	-	240 MHz
HSE_B ²	80 MHz	120 MHz	80 MHz	80 MHz	80 MHz	120 MHz	120 MHz	80 MHz	120 MHz
FIRC	ON	ON	ON	ON	ON	ON	ON	ON	ON
FXOSC	ON	ON	ON	ON	ON	ON	ON	ON	ON
SIRC	ON	ON	ON	ON	ON	ON	ON	ON	ON
PLL	ON	ON	ON	ON	ON	ON	ON	ON	ON
Flash	ON	ON	ON	ON	ON	ON	ON	ON	ON
eDMA	ON	ON	ON	ON	ON	ON	ON	ON	ON
FlexCAN ³	All OFF	All OFF	All OFF	6x	2x	4x	6x	1x	8x
LPUART ⁴	All OFF	All OFF	All OFF	16x	4x	10x	8x	7x	16x
LPSPi ⁵	All OFF	All OFF	All OFF	6x	4x	4x	4x	3x	5x
LPI2C ⁶	All OFF	All OFF	All OFF	All OFF	2x	2x	2x	All OFF	1x
EMAC ⁷	OFF	OFF	OFF	ON	OFF	ON	OFF	OFF	ON
SAI	OFF	OFF	OFF	OFF	OFF	OFF	OFF	OFF	OFF
QSPI	OFF	OFF	OFF	OFF	OFF	OFF	OFF	OFF	ON
eMIOS ⁸	All OFF	All OFF	All OFF	All OFF	3x	3x	2x	2x	2x
SAR_ADC ⁹	All OFF	All OFF	All OFF	All OFF	3x	3x	2x	2x	3x
LPCMP ¹⁰	All OFF	All OFF	All OFF	All OFF	2x	3x	All OFF	All OFF	OFF

1. See clocking use case examples in the Clocking chapter of the S32K3xx Reference Manual.
2. HSE_B: After start-up, the HSE core is in WFI.
3.
 - FlexCAN0: Transmitting an 8-byte CAN-FD data frame at 5 Mbps, every 10 ms.
 - FlexCAN1: Transmitting a 64-byte CAN-FD data frame at 2 Mbps, every 20 ms.
 - FlexCAN2-5: Transmitting an 8-byte CAN data frame at 500 Kbps, every 20 ms.
4. LPUART0-15: Transmitting at 19200 bps, every 100ms.
5.
 - LPSPi0: Transmitting 32 bits at 20 Mbps (GPIO Fast pads), every 5 ms.
 - LPSPi1-5: Transmitting 32 bits at 1 Mbps, every 5 ms.
6. LPI2C0-1: Transmitting 3 bytes at 400 Kbps, every 100ms.
7. EMAC: ON for MII interface.
8.
 - eMIOS0: 6 channels in PWM mode @ 20 KHz.
 - eMIOS1-2: 8 channels in PWM mode @ 400 Hz.
9.
 - SAR_ADC0: 16 channels at 400 Hz rate, BCTU triggered.
 - SAR_ADC1-2: 4 channels at 20 KHz rate, BCTU triggered.

10. LPCMP0: 8 channels enabled; LPCMP1-2: 4 channels enabled.

6.11 Cyclic wake-up current

The cyclic wake-up current is the calculated average current consumption during the periodic switching between RUN mode and STANDBY mode. This average current can be calculated with the following formula:

$$ICYCL = RUN \text{ Current According to Ratio} + STANDBY \text{ Current According to Ratio}$$

Where the Current According to Ratio value is calculated as follows:

$$Current \text{ According to Ratio} = Supply \text{ Current} \times Ratio \text{ of Duration}$$

As an example, the following data was obtained with an application that periodically (every 40ms) alternates between RUN mode, for approximately 200µs to scan several GPIO inputs (51 GPIOs), and spends the rest of the time in STANDBY mode.

Chip	Device Operating Mode	Supply Current ¹ [µA]	Duration ² [ms]	Ratio of Duration ³	Current According to Ratio ⁴ [µA]	ICYCL - Average current ⁵ [µA]
S32K314	RUN	20000	0.2	0.005	100	159.7
	STANDBY	60	39.8	0.995	59.7	

1. The supply current is obtained through the measurements of the current during the corresponding operating mode.
2. The duration is defined by the application (how much time will the device spend in the according operating mode).
3. The ratio of duration is obtained by dividing the duration of the corresponding operating mode by the total duration of the application.
4. The current according to ratio is obtained by multiplying the supply current and the ratio of duration related to the proper operating mode.
5. The average current is calculated by the addition of each device operating mode's current according to ratio.

7 I/O parameters

7.1 GPIO DC electrical specifications, 3.3V Range (2.97V - 3.63V)

Table 20. GPIO DC electrical specifications, 3.3V Range (2.97V - 3.63V)

Symbol	Description	Min	Typ	Max	Unit	Condition	Spec Number
VIH	Input high level DC voltage threshold	0.70 x VDD_HV_A/B	—	VDD_HV_A/B + 0.3	V	VDD_HV_A/B = 3.3V	—
VIL	Input low level DC voltage threshold	VSS - 0.3	—	0.30 x VDD_HV_A/B	V	VDD_HV_A/B = 3.3V	—
WFRST	RESET Input Filtered pulse width ¹	—	—	33	ns	—	—
WNFRST	RESET Input not filtered pulse width ²	100	—	—	ns	—	—
ILKG_33_S	3.3V input leakage current for Standard GPIO ³	-160	—	600	nA	Analog Function Count=0	—

Table continues on the next page...

Table 20. GPIO DC electrical specifications, 3.3V Range (2.97V - 3.63V) (continued)

Symbol	Description	Min	Typ	Max	Unit	Condition	Spec Number
ILKG_33_S	3.3V input leakage current for Standard GPIO ³	-1020	—	870	nA	Analog Function Count=1	—
ILKG_33_S	3.3V input leakage current for Standard GPIO ³	-1880	—	1140	nA	Pins with Analog Function Count=2, plus PTD1, PTA12	—
ILKG_33_S	3.3V input leakage current for Standard GPIO ³	-2740	—	1410	nA	Pins with Analog Function Count=3, plus PTD0	—
ILKG_33_S_PTE13	3.3V input leakage current for Standard GPIO ³	-4400	—	2030	nA	PMC VRC_CTRL pin	—
ILKG_33_SP	3.3V input leakage current for Standard Plus GPIO, input only, and reset IO ³	-420	—	1270	nA	Analog Function Count=0	—
ILKG_33_SP	3.3V input leakage current for Standard Plus GPIO, input only, and reset IO ³	-1270	—	1530	nA	Analog Function Count=1	—
ILKG_33_SP	3.3V input leakage current for Standard Plus GPIO, input only, and reset IO ³	-2130	—	1800	nA	Analog Function Count=2	—
ILKG_33_M	3.3V GPIO input leakage current for Medium GPIO pad ³	-710	—	1630	nA	Analog Function Count=0	—
ILKG_33_M	3.3V GPIO input leakage current for Medium GPIO pad ³	-1560	—	1900	nA	Pins with Analog Function Count=1, plus PTD5, PTC16	—
ILKG_33_M	3.3V GPIO input leakage current for Medium GPIO pad ³	-2410	—	2170	nA	PTE8 and PTD6	—
ILKG_33_F	3.3V GPIO input leakage current for Fast GPIO pad ³	-1340	—	2720	nA	Analog Function Count=0	—
ILKG_33_F	3.3V GPIO input leakage current for Fast GPIO pad ³	-2200	—	2990	nA	Analog Function Count=1	—
ILKG_33	3.3V input leakage current for GPI ³	-120	—	120	nA	—	—

Table continues on the next page...

Table 20. GPIO DC electrical specifications, 3.3V Range (2.97V - 3.63V) (continued)

Symbol	Description	Min	Typ	Max	Unit	Condition	Spec Number
VHYS_33	input hysteresis voltage	0.06 x VDD_HV_A/B	—	—	mV	Always enabled.	—
CIN	GPIO Input capacitance	2	4	6	pF	add 2pF for package/parasitic	—
IPU_33	3.3V GPIO pull up/down resistance	20	—	60	kΩ	pull up @ 0.3 x VDD_HV_A/B, pull down @ 0.7 x VDD_HV_A/B	—
IOH_33_S	3.3V output high current for Standard GPIO ⁴	1.0	—	—	mA	VOH >= VDD_HV_A/B - 0.7V	—
IOH_33_SP	3.3V output high current for Standard Plus GPIO and RESET IO ⁴	1.5	—	—	mA	DSE = 0, VOH >= VDD_HV_A/B - 0.7V	—
IOH_33_M	3.3V output high current for Medium GPIO ⁴	3	—	—	mA	DSE = 0, VOH >= VDD_HV_A/B - 0.7V	—
IOH_33_F	3.3V output high current for Fast GPIO ⁴	4.5	—	—	mA	DSE = 0, VOH >= VDD_HV_A/B - 0.7V	—
IOH_33_SP	3.3V output high current for Standard Plus GPIO and RESET IO ⁴	3	—	—	mA	DSE = 1, VOH >= VDD_HV_A/B - 0.7V	—
IOH_33_M	3.3V output high current for Medium GPIO ⁴	6	—	—	mA	DSE = 1, VOH >= VDD_HV_A/B - 0.7V	—
IOH_33_F	3.3V output high current for Fast GPIO ⁴	9	—	—	mA	DSE = 1, VOH >= VDD_HV_A/B - 0.7V	—
IOL_33_S	3.3V output low current for Standard GPIO ⁴	1.0	—	—	mA	VOL <= 0.7V	—
IOL_33_SP	3.3V output low current for Standard Plus GPIO and RESET IO ⁴	1.5	—	—	mA	DSE = 0, VOL <= 0.7V	—
IOL_33_M	3.3V output low current for Medium GPIO ⁴	3.0	—	—	mA	DSE = 0, VOL <= 0.7V	—

Table continues on the next page...

Table 20. GPIO DC electrical specifications, 3.3V Range (2.97V - 3.63V) (continued)

Symbol	Description	Min	Typ	Max	Unit	Condition	Spec Number
IOL_33_F	3.3V output low current for Fast GPIO ⁴	4.5	—	—	mA	DSE =0, VOL <= 0.7V	—
IOL_33_SP	3.3V output low current for Standard Plus GPIO and RESET IO ⁴	3	—	—	mA	DSE =1, VOL <= 0.7V	—
IOL_33_M	3.3V output low current for Medium GPIO ⁴	6	—	—	mA	DSE =1, VOL <= 0.7V	—
IOL_33_F	3.3V output low current for Fast GPIO ⁴	9	—	—	mA	DSE =1, VOL <= 0.7V	—
FMAX_33_S	3.3V maximum frequency for Standard GPIO ^{4, 5}	—	—	10	MHz	2.9V - 3.6V, internal 5pF, PCB trace ~10pF and external 10pF, total 25pF load	—
FMAX_33_SP	3.3V maximum frequency for Standard Plus GPIO ^{4, 5}	—	—	25	MHz	2.9V - 3.6V, internal 5pF, PCB trace ~10pF and external 10pF, total 25pF load	—
FMAX_33_M	3.3V maximum frequency for Medium GPIO ^{4, 5}	—	—	50	MHz	2.9V - 3.6V, internal 5pF, PCB trace ~10pF and external 10pF, total 25pF load	—
FMAX_33_F	3.3V maximum frequency for Fast GPIO ^{4, 5}	—	—	120	MHz	2.9V - 3.6V, internal 5pF, PCB trace ~10pF and external 10pF, total 25pF load	—
IOHT	Output high current total for all ports	—	—	100	mA	—	—

1. Maximum length of RESET pulse will be filtered by an internal filter on this pin.
2. Minimum length of RESET pulse, guaranteed not to be filtered by the internal filter.
3. A positive value is leakage flowing into pin with pin at VDD_HV_A/B (the GPIO supply level); a negative value is leakage flowing out the pin with the pin at ground.
4. GPIO output transition time information can be obtained from the device IBIS model. IBIS models are recommended for system level simulations, as discrete values for I/O transition times are not representative of the I/O pad behavior when connected to an actual transmission line load.
5. I/O timing specifications are valid for the un-terminated transmission line reference load given in the figure below. A lumped 8pF load is assumed at the end of a 5 inch microstrip trace on standard FR4 with approximately 1.5pF/inch (25pF total with margin). For signals with frequency greater than 63MHz, a maximum 2 inch PCB trace is assumed.

I/O current specifications are valid for the given reference load figure, and the constraints given in the Operating Conditions of this document. The "Analog Function Count" is defined from the number of CMP and ADC channels multiplexed to a given pin. This information can be obtained from the "Direct Signals" column in the IOMUX file attached to the Reference Manual.

To determine total switching current on any I/O supply, current values per output pin should not be incrementally summed. I/O interfaces on the device are asynchronous to each other, so not all switching occurs at the same instant. Actual use case must be considered.

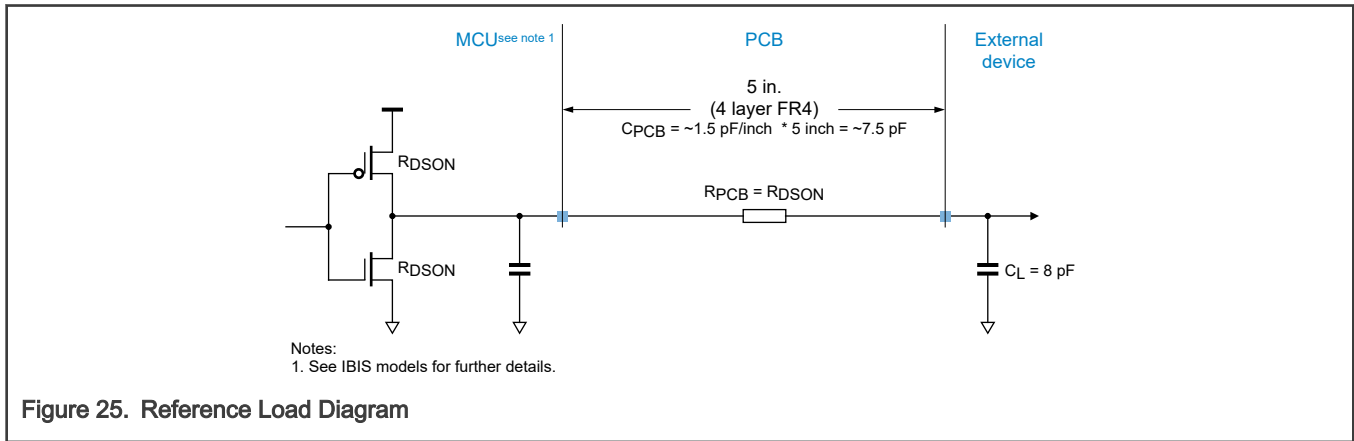

Figure 25. Reference Load Diagram

7.2 GPIO DC electrical specifications, 5.0V (4.5V - 5.5V)

Table 21. GPIO DC electrical specifications, 5.0V (4.5V - 5.5V)

Symbol	Description	Min	Typ	Max	Unit	Condition	Spec Number
V _{IH}	Input high level DC voltage threshold	0.65 x V _{DD_HV_A/B}	—	V _{DD_HV_A/B} + 0.3	V	V _{DD_HV_A/B} = 5.0V	—
V _{IL}	Input low level DC voltage threshold	V _{SS} - 0.3	—	0.35 x V _{DD_HV_A/B}	V	V _{DD_HV_A/B} = 5.0V	—
WFRST	RESET Input filtered pulse width ¹	—	—	33	ns	—	—
WNFRST	RESET Input not filtered pulse width ²	100	—	—	ns	—	—
ILKG_50_S	5.0V input leakage current for Standard GPIO ³	-250	—	800	nA	Analog Function Count=0	—
ILKG_50_S	5.0V input leakage current for Standard GPIO ³	-1300	—	1100	nA	Analog Function Count=1	—
ILKG_50_S	5.0V input leakage current for Standard GPIO ³	-2300	—	1450	nA	Pins with Analog Function Count=2, plus PTD1, PTA12	—
ILKG_50_S	5.0V input leakage current for Standard GPIO ³	-3300	—	1750	nA	Pins with Analog Function Count=3, plus PTD0	—

Table continues on the next page...

Table 21. GPIO DC electrical specifications, 5.0V (4.5V - 5.5V) (continued)

Symbol	Description	Min	Typ	Max	Unit	Condition	Spec Number
ILKG_50_S_PTE13	5.0V input leakage current for Standard GPIO ³	-3300	—	1750	nA	PMC VRC_CTRL pin	—
ILKG_50_SP	5.0V input leakage current for Standard Plus GPIO and RESET IO ³	-660	—	1760	nA	Analog Function Count=0	—
ILKG_50_SP	5.0V input leakage current for Standard Plus GPIO and RESET IO ³	-1510	—	2030	nA	Analog Function Count=1	—
ILKG_50_SP	5.0V input leakage current for Standard Plus GPIO and RESET IO ³	-2450	—	2290	nA	Analog Function Count=2	—
ILKG_50_M	5.0V input leakage current for Medium GPIO ³	-1110	—	2270	nA	Analog Function Count=0	—
ILKG_50_M	5.0V input leakage current for Medium GPIO ³	-1970	—	2540	nA	Pins with Analog Function Count=1, plus PTD5, PTC16	—
ILKG_50_M	5.0V input leakage current for Medium GPIO ³	-2830	—	2810	nA	PTE8 and PTD6	—
ILKG_50_F	5.0V input leakage current for Fast GPIO ³	-2120	—	3790	nA	Analog Function Count=0	—
ILKG_50_F	5.0V input leakage current for Fast GPIO ³	-2980	—	4060	nA	Analog Function Count=1	—
ILKG_50	5.0V input leakage current for GPI ³	-150	—	150	nA	—	—
VHYS_50	input hysteresis voltage	0.06 x VDD_HV_A/B	—	—	mV	Always enabled.	—
CIN	GPIO Input capacitance	2	4	6	pF	add 2pF for package/parasitic	—
IPU_50	5.0V GPIO pull up/down resistance	20	—	55	kΩ	pull up @ 0.3 * VDD_HV_*, pull down @ 0.7 * VDD_HV_*	—

Table continues on the next page...

Table 21. GPIO DC electrical specifications, 5.0V (4.5V - 5.5V) (continued)

Symbol	Description	Min	Typ	Max	Unit	Condition	Spec Number
IOH_50_S	5.0V output high current Standard GPIO ⁴	1.6	—	—	mA	VOH >= VDD_HV_A/B - 0.7V	—
IOH_50_SP	5.0V output high current Standard Plus GPIO and RESET IO ⁴	2.5	—	—	mA	DSE = 0, VOH >= VDD_HV_A/B - 0.7V	—
IOH_50_M	5.0V output high current for Medium GPIO ⁴	4.0	—	—	mA	DSE = 0, VOH >= VDD_HV_A/B - 0.7V	—
IOH_50_F	5.0V output high current for Fast GPIO ⁴	6.0	—	—	mA	DSE = 0, VOH >= VDD_HV_A/B - 0.7V	—
IOH_50_SP	5.0V output high current for Standard Plus GPIO and RESET IO ⁴	5.0	—	—	mA	DSE = 1, VOH >= VDD_HV_A/B - 0.7V	—
IOH_50_M	5.0V output high current for Medium GPIO ⁴	8.0	—	—	mA	DSE = 1, VOH >= VDD_HV_A/B - 0.7V	—
IOH_50_F	5.0V GPIO output high current for Fast GPIO ⁴	12.0	—	—	mA	DSE = 1, VOH >= VDD_HV_A/B - 0.7V	—
IOL_50_S	5.0V output low current for Standard GPIO ⁴	1.6	—	—	mA	VOL <= 0.7V	—
IOL_50_SP	5.0V output low current for Standard Plus GPIO and RESET IO ⁴	2.5	—	—	mA	DSE = 0, VOL <= 0.7V	—
IOL_50_M	5.0V output low current for Medium GPIO ⁴	4.0	—	—	mA	DSE = 0, VOL <= 0.7V	—
IOL_50_F	5.0V output low current for Fast GPIO ⁴	6.0	—	—	mA	DSE = 0, VOL <= 0.7V	—
IOL_50_SP	5.0V output low current for Standard Plus GPIO and RESET IO ⁴	5.0	—	—	mA	DSE = 1, VOL <= 0.7V	—

Table continues on the next page...

Table 21. GPIO DC electrical specifications, 5.0V (4.5V - 5.5V) (continued)

Symbol	Description	Min	Typ	Max	Unit	Condition	Spec Number
IOL_50_M	5.0V output low current for medium GPIO ⁴	8.0	—	—	mA	DSE =1, VOL <= 0.7V	—
IOL_50_F	5.0V output low current for Fast GPIO ⁴	12.0	—	—	mA	DSE =1, VOL <= 0.7V	—
FMAX_50_S	5.0V maximum frequency for Standard GPIO ^{4, 5}	—	—	10	MHz	3.6V - 5.5V, total 25pF load includes internal 5pF, PCB trace ~10pF and external 10pF.	—
FMAX_50_SP	5.0V maximum frequency for Standard Plus GPIO ^{4, 5}	—	—	25	MHz	3.6V - 5.5V, total 25pF load includes internal 5pF, PCB trace ~10pF and external 10pF.	—
FMAX_50_M	5.0V maximum frequency for Medium GPIO ^{4, 5}	—	—	25	MHz	3.6V - 5.5V, total 25pF load includes internal 5pF, PCB trace ~10pF and external 10pF	—
FMAX_50_F	5.0V maximum frequency for Fast GPIO ^{4, 5}	—	—	25	MHz	3.6V - 5.5V, total 25pF load includes internal 5pF, PCB trace ~10pF and external 10pF.	—
IOHT	Output high current total for all ports	—	—	100	mA	—	—

1. Maximum length of RESET pulse will be filtered by an internal filter on this pin.
2. Minimum length of RESET pulse, guaranteed not to be filtered by the internal filter.
3. A positive value is leakage flowing into pin with pin at VDD_HV_A/B (the GPIO supply level); a negative value is leakage flowing out the pin with the pin at ground.
4. GPIO output transition time information can be obtained from the device IBIS model. IBIS models are recommended for system level simulations
5. I/O timing specifications are valid for the un-terminated transmission line reference load given in the figure below. A lumped 8pF load is assumed at the end of a 5 inch microstrip trace on standard FR4 with approximately 1.5pF/inch (25pF total with margin).

I/O current specifications are valid for the given reference load figure, and the constraints given in the Operating Conditions of this document. The "Analog Function Count" is defined from the number of CMP and ADC channels multiplexed to a given pin. This information can be obtained from the "Direct Signals" column in the IOMUX file attached to the Reference Manual.

To determine total switching current on any I/O supply, current values per output pin should not be incrementally summed. I/O interfaces on the device are asynchronous to each other, so not all switching occurs at the same instant. Actual use case must be considered.

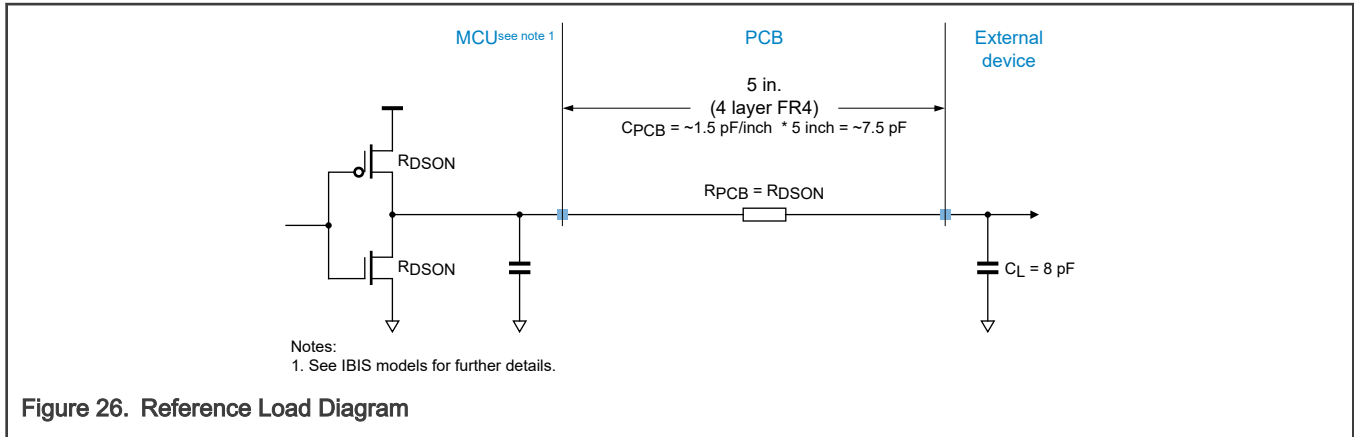

Figure 26. Reference Load Diagram

7.3 5.0V (4.5V - 5.5V) GPIO Output AC Specification

Table 22. 5.0V (4.5V - 5.5V) GPIO Output AC Specification

Symbol	Description	Min	Typ	Max	Unit	Condition	Spec Number
TR_TF_50_S	5.0V Standard GPIO rise/fall time	5	—	21	ns	Capacitance=25pF	—
TR_TF_50_S	5.0V Standard GPIO rise/fall time	10	—	31	ns	Capacitance=50pF	—
TR_TF_50_SP	5.0V Standard Plus GPIO rise/fall time	3.5	—	13.2	ns	DSE=0, Capacitance=25pF	—
TR_TF_50_SP	5.0V Standard Plus GPIO rise/fall time	1.2	—	7.1	ns	DSE=1, Capacitance=25pF	—
TR_TF_50_SP	5.0V Standard Plus GPIO rise/fall time	7.1	—	18.8	ns	DSE=0, Capacitance=50pF	—
TR_TF_50_SP	5.0V Standard Plus GPIO rise/fall time	3.4	—	11	ns	DSE=1, Capacitance=50pF	—
TR_TF_50_M	5.0V Medium GPIO rise/fall time	1.8	—	8.2	ns	DSE=0, SRE=0, Capacitance=25pF	—
TR_TF_50_M	5.0V Medium GPIO rise/fall time	2.5	—	9.8	ns	DSE=0, SRE=1, Capacitance=25pF	—
TR_TF_50_M	5.0V Medium GPIO rise/fall time	0.8	—	4.5	ns	DSE=1, SRE=0, Capacitance=25pF	—
TR_TF_50_M	5.0V Medium GPIO rise/fall time	1.8	—	7.2	ns	DSE=1, SRE=1, Capacitance=25pF	—
TR_TF_50_M	5.0V Medium GPIO rise/fall time	4.3	—	13.2	ns	DSE=0, SRE=0, Capacitance=50pF	—
TR_TF_50_M	5.0V Medium GPIO rise/fall time	4.6	—	13.8	ns	DSE=0, SRE=1, Capacitance=50pF	—

Table continues on the next page...

Table 22. 5.0V (4.5V - 5.5V) GPIO Output AC Specification (continued)

Symbol	Description	Min	Typ	Max	Unit	Condition	Spec Number
TR_TF_50_M	5.0V Medium GPIO rise/fall time	1.6	—	7.1	ns	DSE=1, SRE=0, Capacitance=50pF	—
TR_TF_50_M	5.0V Medium GPIO rise/fall time	2.7	—	9.6	ns	DSE=1, SRE=1, Capacitance=50pF	—
TR_TF_50_F	5.0V Fast GPIO rise/fall time	0.4	—	3.1	ns	DSE=0, SRE=0, Capacitance=25pF	—
TR_TF_50_F	5.0V Fast GPIO rise/fall time	1.5	—	6.1	ns	DSE=0, SRE=1, Capacitance=25pF	—
TR_TF_50_F	5.0V Fast GPIO rise/fall time	0.3	—	0.9	ns	DSE=1, SRE=0, Capacitance=25pF	—
TR_TF_50_F	5.0V Fast GPIO rise/fall time	0.9	—	4.1	ns	DSE=1, SRE=1, Capacitance=25pF	—
TR_TF_50_F	5.0V Fast GPIO rise/fall time	1.0	—	5.3	ns	DSE=0, SRE=0, Capacitance=50pF	—
TR_TF_50_F	5.0V Fast GPIO rise/fall time	1.9	—	7.7	ns	DSE=0, SRE=1, Capacitance=50pF	—
TR_TF_50_F	5.0V Fast GPIO rise/fall time	0.9	—	3.0	ns	DSE=1, SRE=0, Capacitance=50pF	—
TR_TF_50_F	5.0V Fast GPIO rise/fall time	1.3	—	5.1	ns	DSE=1, SRE=1, Capacitance=50pF	—

7.4 3.3V (2.97V - 3.63V) GPIO Output AC Specification

Table 23. 3.3V (2.97V - 3.63V) GPIO Output AC Specification

Symbol	Description	Min	Typ	Max	Unit	Condition	Spec Number
TR_TF_33_S	3.3V Standard GPIO rise/fall time	6.5	—	28	ns	Capacitance=25pF	—
TR_TF_33_S	3.3V Standard GPIO rise/fall time	11	—	43	ns	Capacitance=50pF	—
TR_TF_33_SP	3.3V Standard Plus GPIO rise/fall time	4	—	17.5	ns	DSE=0, Capacitance=25pF	—
TR_TF_33_SP	3.3V Standard Plus GPIO rise/fall time	2.0	—	10	ns	DSE=1, Capacitance=25pF	—
TR_TF_33_SP	3.3V Standard Plus GPIO rise/fall time	8.9	—	27	ns	DSE=0, Capacitance=50pF	—
TR_TF_33_SP	3.3V Standard Plus GPIO rise/fall time	4.1	—	15	ns	DSE=1, Capacitance=50pF	—

Table continues on the next page...

Table 23. 3.3V (2.97V - 3.63V) GPIO Output AC Specification (continued)

Symbol	Description	Min	Typ	Max	Unit	Condition	Spec Number
TR_TF_33_M	3.3V Medium GPIO rise/fall time	2.2	—	12.3	ns	DSE=0, SRE=0, Capacitance=25pF	—
TR_TF_33_M	3.3V Medium GPIO rise/fall time	3.0	—	14	ns	DSE=0, SRE=1, Capacitance=25pF	—
TR_TF_33_M	3.3V Medium GPIO rise/fall time	0.8	—	6.6	ns	DSE=1, SRE=0, Capacitance=25pF	—
TR_TF_33_M	3.3V Medium GPIO rise/fall time	2.4	—	10.5	ns	DSE=1, SRE=1, Capacitance=25pF	—
TR_TF_33_M	3.3V Medium GPIO rise/fall time	5.1	—	17.3	ns	DSE=0, SRE=0, Capacitance=50pF	—
TR_TF_33_M	3.3V Medium GPIO rise/fall time	5.8	—	19.8	ns	DSE=0, SRE=1, Capacitance=50pF	—
TR_TF_33_M	3.3V Medium GPIO rise/fall time	2.2	—	10	ns	DSE=1, SRE=0, Capacitance=50pF	—
TR_TF_33_M	3.3V Medium GPIO rise/fall time	3.7	—	13.9	ns	DSE=1, SRE=1, Capacitance=50pF	—
TR_TF_33_F	3.3V Fast GPIO rise/fall time	0.5	—	4	ns	DSE=0, SRE=0, Capacitance=25pF	—
TR_TF_33_F	3.3V Fast GPIO rise/fall time	2.1	—	9	ns	DSE=0, SRE=1, Capacitance=25pF	—
TR_TF_33_F	3.3V Fast GPIO rise/fall time	0.4	—	2	ns	DSE=1, SRE=0, Capacitance=25pF	—
TR_TF_33_F	3.3V Fast GPIO rise/fall time	1.2	—	6.4	ns	DSE=1, SRE=1, Capacitance=25pF	—
TR_TF_33_F	3.3V Fast GPIO rise/fall time	1.1	—	7	ns	DSE=0, SRE=0, Capacitance=50pF	—
TR_TF_33_F	3.3V Fast GPIO rise/fall time	2.6	—	11	ns	DSE=0, SRE=1, Capacitance=50pF	—
TR_TF_33_F	3.3V Fast GPIO rise/fall time	0.8	—	4.2	ns	DSE=1, SRE=0, Capacitance=50pF	—
TR_TF_33_F	3.3V Fast GPIO rise/fall time	1.5	—	7.8	ns	DSE=1, SRE=1, Capacitance=50pF	—

8 Glitch Filter

The glitch filter parameters in the following table apply to the filters of WKPU pins and TRGMUX inputs 60-63.

Table 24. Glitch Filter

Symbol	Description	Min	Typ	Max	Unit	Condition	Spec Number
TFILT	Glitch filter max filtered pulse width ^{1, 2, 3}	—	—	20	ns	—	—
TUNFILT	Glitch filter min unfiltered pulse width ^{1, 3, 4}	400	—	—	ns	—	—

1. An input signal pulse is defined by the duration between the input signal's crossing of a V_{il}/V_{ih} threshold voltage level, and the next crossing of the opposite level.
2. Pulses shorter than defined by the maximum value are guaranteed to be filtered (not passed).
3. Pulses in between the max filtered and min unfiltered may or may not be passed through.
4. Pulses larger than defined by the minimum value are guaranteed to not be filtered (passed).

9 Flash memory specification

9.1 Flash memory program and erase specifications

Table 25. Flash memory program and erase specifications

Symbol	Characteristic ¹	Typ ²	Factory Programming ^{3,4}		Field Update			Unit
			Initial Max	Initial Max, Full Temp	Typical End of Life ⁵	Lifetime Max ⁶		
			$20^{\circ}\text{C} \leq T_A \leq 30^{\circ}\text{C}$	$-40^{\circ}\text{C} \leq T_J \leq 150^{\circ}\text{C}$	$-40^{\circ}\text{C} \leq T_J \leq 150^{\circ}\text{C}$	$\leq 1,000$ cycles	$\leq 100,000$ cycles	
$t_{dwp\text{pgm}}$	Doubleword (64 bits) program time	102	122	129	111	150		μs
$t_{pp\text{pgm}}$	Page (256 bits) program time	142	171	180	157	200		μs
$t_{qpp\text{pgm}}$	Quad-page (1024 bits) program time	314	377	396	341	450		μs
$t_{8k\text{pgm}}$	8 KB Sector program time	20	24	26	22	30		ms
$t_{8k\text{ers}}$	8 KB Sector erase time	4.8	8.5	10.6	6.5	30		ms
$t_{256k\text{bers}}$	256KB Block erase time	22.8	27.4	28.8	24.4	40	—	ms
$t_{512k\text{bers}}$	512KB Block erase time	25.4	30.5	32.1	27.9	45	—	ms
$t_{1m\text{bers}}$	1MB Block erase time	30.6	36.8	38.7	33.6	50	—	ms
$t_{2m\text{bers}}$	2MB Block erase time	41.1	49.3	51.8	45.2	60	—	ms

1. Program times are actual hardware programming times and do not include software overhead. Sector program times assume quad-page programming.

2. Typical program and erase times represent the median performance and assume nominal supply values and operation at 25 °C. Typical program and erase times may be used for throughput calculations.
3. Conditions: ≤ 25 cycles, nominal voltage.
4. Plant Programming times provide guidance for timeout limits used in the factory.
5. Typical End of Life program and erase times represent the median performance and assume nominal supply values. Typical End of Life program and erase values may be used for throughput calculations.
6. Conditions: $-40^{\circ}\text{C} \leq T_J \leq 150^{\circ}\text{C}$, full spec voltage.

9.2 Flash memory Array Integrity and Margin Read specifications

Table 26. Flash memory Array Integrity and Margin Read specifications

Symbol	Characteristic	Min	Typical	Max ^{1 2}	Units ³
$t_{ai256kseq}$	Array Integrity time and Margin Read time for sequential sequence on 256KB block.	—	—	8192 x Tperiod x Nread (plus 40uS adder required if User Margin Read)	—
$t_{ai512kseq}$	Array Integrity time and Margin Read time for sequential sequence on 512KB block.	—	—	16384 x Tperiod x Nread (plus 40uS adder required if User Margin Read)	—
$t_{ai1mseq}$	Array Integrity time and Margin Read time for sequential sequence on 1MB block.	—	—	32768 x Tperiod x Nread (plus 40uS adder required if User Margin Read)	—
$t_{ai2mseq}$	Array Integrity time and Margin Read time for sequential sequence on 2MB block.	—	—	65536 x Tperiod x Nread (plus 40uS adder required if User Margin Read)	—
$t_{ai256kprop}$	Array Integrity time for proprietary sequence on 256KB block.	—	—	106496 x Tperiod x Nread	—
$t_{ai512kprop}$	Array Integrity time for proprietary sequence on 512KB block.	—	—	229376 x Tperiod x Nread	—
$t_{ai1mprop}$	Array Integrity time for proprietary sequence on 1MB block.	—	—	491520 x Tperiod x Nread	—
$t_{ai2mprop}$	Array Integrity time for proprietary sequence on 2MB block.	—	—	1048576 x Tperiod x Nread	—

1. Array Integrity times need to be calculated and is dependent on system frequency and number of clocks per read. The equation presented require Tperiod (which is the unit accurate period, thus for 200 MHz, Tperiod would equal 5e-9) and Nread (which is the number of clocks required for read, including single read, dual read, quad read contribution. Thus for a read setup that requires 6 clocks to read Nread would equal 6).
2. Array Integrity times are actual hardware execution times and do not include software overhead or system code execution overhead.
3. The units for Array Integrity are determined by the period of the system clock. If unit accurate period is used in the equation, the results of the equation are also unit accurate.

9.3 Flash memory module life specifications

Table 27. Flash memory module life specifications

Symbol	Characteristic	Conditions	Min	Typical	Units
Array P/E cycles	Number of program/erase cycles per block for 256 KB and 512 KB blocks using Sector Erase.	—	100,000	—	P/E cycles
	Number of program/erase cycles per block for 1 MB and 2 MB blocks using Sector Erase.	—	1,000	—	P/E cycles
	Number of program/erase cycles per block using Block Erase ¹	—	25	—	P/E cycles
Data retention	Minimum data retention.	Blocks with 0 - 1,000 P/E cycles.	20	—	Years
		Blocks with 100,000 P/E cycles.	10	—	Years

1. Program and erase supported for factory conditions. Nominal supply values and operation at 25°C.

9.3.1 Data retention vs program/erase cycles

Graphically, Data Retention versus Program/Erase Cycles can be represented by the following figure.

The spec window represents qualified limits.

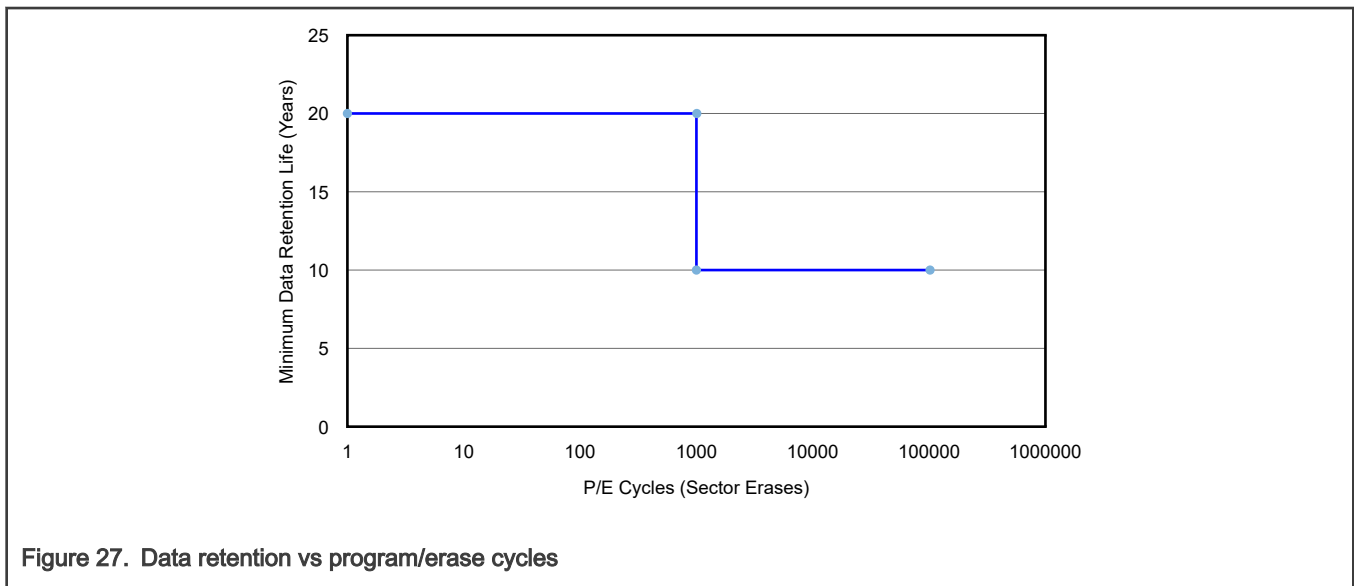

Figure 27. Data retention vs program/erase cycles

9.4 Flash memory AC timing specifications

Table 28. Flash memory AC timing specifications

Symbol	Characteristic	Min	Typical	Max	Units
t _{done}	Time from 0 to 1 transition on the MCR[EHV] bit initiating a program/erase until the MCR[DONE] bit is cleared.	—	—	5	ns
t _{dones}	Time from 1 to 0 transition on the MCR[EHV] bit aborting a program/erase until the MCR[DONE] bit is set to a 1.	5 plus four system clock periods	—	22 plus four system clock periods ¹	µs
t _{drcv}	Time to recover once exiting low power mode.	14 plus seven system clock periods ²	17.5 plus seven system clock periods	21 plus seven system clock periods	µs
t _{aistart}	Time from 0 to 1 transition of UT0[AIE] initiating a Margin Read or Array Integrity until the UT0[AID] bit is cleared. This time also applies to the resuming from a suspend or breakpoint by clearing UT0[AISUS] or clearing UT0[NAIBP]	—	—	5	ns
t _{aistop}	Time from 1 to 0 transition of UT0[AIE] initiating an Array Integrity abort until the UT0[AID] bit is set. This time also applies to the UT0[AISUS] to UT0[AID] setting in the event of a Array Integrity suspend request.	—	—	50 system clock periods	ns
t _{mrstop}	Time from 1 to 0 transition of UT0[AIE] initiating a Margin Read abort until the UT0[AID] bit is set. This time also applies to the UT0[AISUS] to UT0[AID] setting in the event of a Margin Read suspend request.	—	—	26 plus fifteen system clock periods	µs

1. For Block Erase, Tdones times may be 3x max spec.
2. In extreme cases (1 block configurations) Tdrcv min may be faster (12uS plus seven system clocks)

9.5 Flash memory read timing parameters

Table 29. Flash Read Wait State Settings (S32K344, S32K324, S32K314, S32K342, S32K322, S32K341, S32K312, and S32K311)

Flash Frequency	RWSC setting
250 KHz < Freq ≤ 66 MHz	1
66 MHz < Freq ≤ 100 MHz	2
100 MHz < Freq ≤ 133 MHz	3
133 MHz < Freq ≤ 167 MHz	4
167 MHz < Freq ≤ 200 MHz	5

Table continues on the next page...

Table 29. Flash Read Wait State Settings (S32K344, S32K324, S32K314, S32K342, S32K322, S32K341, S32K312, and S32K311) (continued)

Flash Frequency	RWSC setting
200 MHz < Freq ≤ 233 MHz	6
233 MHz < Freq ≤ 250 MHz	7

Table 30. Flash Read Wait State Settings (S32K358, S32K348, S32K338, and S32K328)

Flash Frequency	RWSC setting
250 KHz < Freq ≤ 60 MHz	1
60 MHz < Freq ≤ 90 MHz	2
90 MHz < Freq ≤ 120 MHz	3
120 MHz < Freq ≤ 150 MHz	4
150 MHz < Freq ≤ 180 MHz	5
180 MHz < Freq ≤ 210 MHz	6
210 MHz < Freq ≤ 240 MHz	7
240 MHz < Freq ≤ 250 MHz	8

10 Analog modules

10.1 SAR ADC

All below specs are applicable when only one ADC instance is in operation and averaging is used. GPIO activity on pins adjacent to ADC channels, or reference, may introduce some degradation on the analog input paths. For parallel/simultaneous operation of two or three ADCs, either for sampling the same channel by each ADC, or for sampling different channels by each ADC, some amount of decrease in performance can be expected. Care must be taken to stagger each ADC conversions, in particular the sample phase, to minimize the impact of simultaneous conversions. ADC performance specifications are guaranteed when calibration uses maximum averaging i.e. when AVGEN = 1 and AVGS = 3. When using ADC averaging, see Reference Manual to determine the most appropriate settings for AVGS.

Table 31. SAR ADC

Symbol	Description	Min	Typ	Max	Unit	Condition	Spec Number
VDD_HV_A	ADC Supply Voltage ¹	2.97	—	5.5	V	—	—
DVREFL	VSS / VREFL Voltage Difference ²	-100	—	100	mV	—	—
VAD_INPUT	ADC Input Voltage ³	VREFL	—	VREFH	V	—	—

Table continues on the next page...

Table 31. SAR ADC (continued)

Symbol	Description	Min	Typ	Max	Unit	Condition	Spec Number
fAD_CK	ADC Clock Frequency (S32K344, S32K324, S32K314, S32K342, S32K341, S32K322)	10	—	80	MHz	—	—
fAD_CK	ADC Clock Frequency (S32K312, S32K311, S32K358, S32K348, S32K338, S32K328)	10	—	120	MHz	—	—
tSAMPLE	ADC Input Sampling Time	275	—	—	ns	—	—
tCONV	ADC Total Conversion Time	1	—	—	us	12-bit result	—
tCONV	ADC Total Conversion Time	0.9	—	—	us	10-bit result	—
CAD_INPUT	ADC Input Capacitance	—	—	13.8	pF	ADC component plus pad capacitance (~2pF)	—
RAD_INPUT	ADC Input Resistance	—	—	4.6	K Ω	ADC + mux+SOC routing	—
RS	Source Impedance, precision channels	—	20	TBD	Ω	—	—
RS	Source Impedance, standard channels	—	20	TBD	Ω	—	—
TUE	ADC Total Unadjusted Error ⁴	—	+/-4	+/-6	LSB	without adjacent pin current injection	—
TUE	ADC Total Unadjusted Error ⁴	—	+/-4	+/-8	LSB	with up to +/-3mA of current injection on adjacent pins	—
IAD_REF	Current Consumption on ADC Reference pin, VREFH.	—	—	200	μ A	Per ADC for dedicated or shared reference pins	—
IDDA	Current Consumption on ADC Supply, VDD_HV_A	—	2.1	—	mA	Current consumption per ADC module, ADC enabled and converting	—
CS	Sampling Capacitance	6.4 (gain=0)	7.36 (gain=0)	8.32 (gain=0)	pF	all channels	—

Table continues on the next page...

Table 31. SAR ADC (continued)

Symbol	Description	Min	Typ	Max	Unit	Condition	Spec Number
		9.72 pF(gain= max)	11.12 pF(gain= max)	12.52 (gain=ma x)			
RAD	Sampling Switch Impedance	80	170	520	Ohm	all channels	—
CP1	Pin capacitance	1.42	—	5.30	pF	all channels	—
CP1	Pin capacitance	1.42	—	4.38	pF	Precision channels	—
CP1	Pin capacitance	1.61	—	5.30	pF	Standard channels	—
CP2	Analog Bus Capacitance	0.32	—	4.18	pF	all channels	—
CP2	Analog Bus Capacitance	0.32	—	1.42	pF	Precision channels	—
CP2	Analog Bus Capacitance	0.497	—	4.18	pF	Standard channels	—
RSW1	Channel selection Switch impedance	65.9	—	1410	Ohm	all channels	—
RSW1	Channel selection Switch impedance	65.9	—	712	Ohm	Precision channels	—
RSW1	Channel selection Switch impedance	65.9	—	1410	Ohm	Standard channels	—

1. Appropriate decoupling capacitors to be used to filter noise on the supplies. See application note AN5032 for reference supply design for SAR ADC.
2. VSS and VREFL should be shorted on PCB. 100mV difference between VSS and VREFL is for transient only (not for DC).
3. This is ADC Input range for ADC accuracy guaranteed in this input range only. For SoC Pin capability, see Operation Condition Section.
4. TUE spec for precision and standard channels is based on 12-bit level resolution.

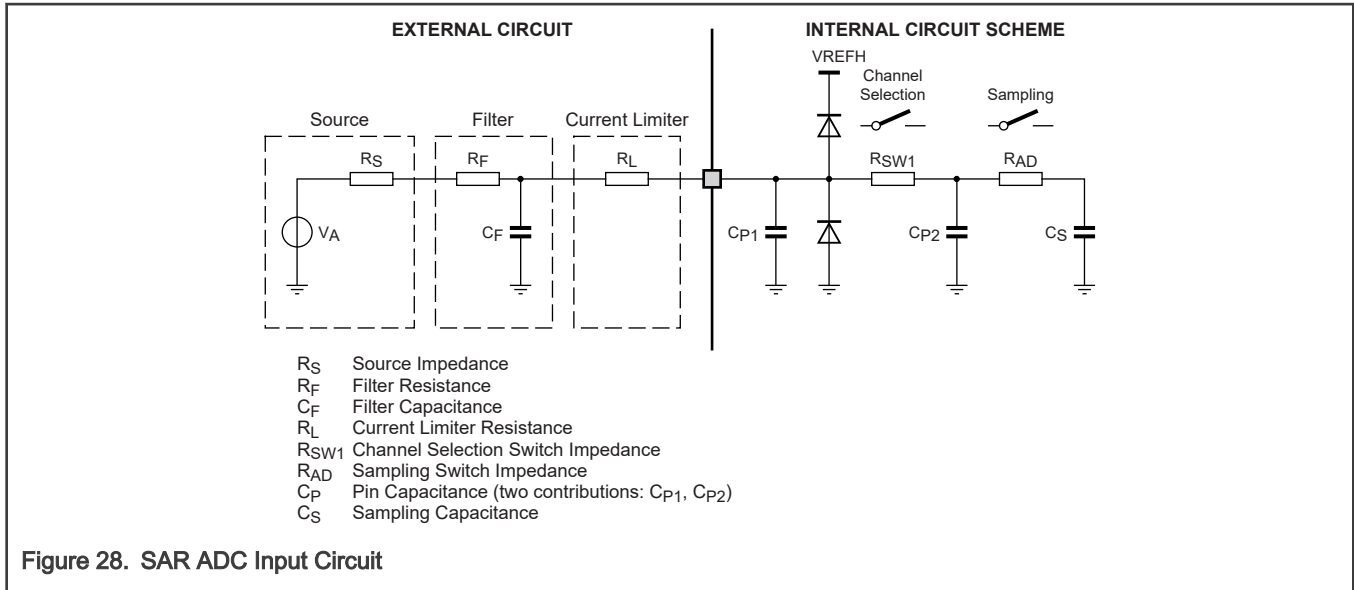

10.2 Supply Diagnosis

The table below gives the specification for the on die supply diagnosis.

Table 32. Supply Diagnosis

Symbol	Description	Min	Typ	Max	Unit	Condition	Spec Number
AN_ACC	Offset to internally monitored supply at ADC input ^{1, 2, 3}	-5	0	5	%	—	—
AN_T_on	Switching time from closed (OFF) to conducting (ON) ³	—	2.5	12	ns	—	—
AN_TADCSA	Required ADC sampling time ¹	1.2	—	—	μ s	—	—

1. Required ADC sampling time specified by parameter AN_TADCSA needs to be used at the ADC conversion to guarantee the specified accuracy. A smaller sampling time leads to a less accurate result.
2. If $V_{15} > V_{DD_HV_A} + 100\text{mV}$ then the V15 measurement via anamux may be imprecise.
3. These specs will have degraded performance when used in extended supply voltage operation range, i.e. normal supply voltage range specification is exceeded.

10.3 Low Power Comparator (LPCMP)

Table 33. Low Power Comparator (LPCMP)

Symbol	Description	Min	Typ	Max	Unit	Condition	Spec Number
idda(IDHSS)	vdda Supply Current, High Speed Mode ^{1, 2}	—	240	—	μ A	—	—

Table continues on the next page...

Table 33. Low Power Comparator (LPCMP) (continued)

Symbol	Description	Min	Typ	Max	Unit	Condition	Spec Number
idda(IDLSS)	vdda Supply Current, Low Speed Mode ^{1,2}	—	17	—	uA	—	—
idda(IDHSS)	vdda Supply Current, high speed mode, DAC only ¹	—	10	—	uA	—	—
idda_lkg	vdda Supply Current, module disabled ¹	—	2	—	nA	vdda=5.5V, T=25C	—
TDHSB	Propagation Delay, High Speed Mode ³	—	—	200	ns	—	—
TDLSB	Propagation Delay, Low Speed mode ³	—	—	2	us	—	—
TDHSS	Propagation Delay, High Speed Mode ⁴	—	—	400	ns	—	—
TDLSS	Propagation Delay, Low Speed mode ⁴	—	—	5	us	—	—
TIDHS	Initialization Delay, High Speed Mode ⁵	—	—	3	us	—	—
TIDLS	Initialization Delay, Low Speed mode ⁵	—	—	30	us	—	—
VAIO	Analog Input Offset Voltage, High Speed Mode	-25	+/-1	25	mV	—	—
VAIO	Analog Input Offset Voltage, Low Speed mode	-40	+ /- 5	40	mV	—	—
VAHYST0	Analog Comparator Hysteresis, High Speed Mode	—	0	—	mV	HYSTCTR[1:0]= 2'b00	—
VAHYST1	Analog Comparator Hysteresis, High Speed Mode	—	14	41	mV	HYSTCTR[1:0]= 2'b01	—
VAHYST2	Analog Comparator Hysteresis, High Speed Mode	—	27	76	mV	HYSTCTR[1:0]= 2'b10	—
VAHYST3	Analog Comparator Hysteresis, High Speed Mode	—	40	111	mV	HYSTCTR[1:0]= 2'b11	—

Table continues on the next page...

Table 33. Low Power Comparator (LPCMP) (continued)

Symbol	Description	Min	Typ	Max	Unit	Condition	Spec Number
VAHYST0	Analog Comparator Hysteresis, Low Speed mode	—	0	—	mV	HYSTCTR[1:0]= 2'b00	—
VAHYST1	Analog Comparator Hysteresis, Low Speed mode	—	8	60	mV	HYSTCTR[1:0]= 2'b01	—
VAHYST2	Analog Comparator Hysteresis, Low Speed mode	—	15	113	mV	HYSTCTR[1:0]= 2'b10	—
VAHYST3	Analog Comparator Hysteresis, Low Speed mode	—	23	165	mV	HYSTCTR[1:0]= 2'b11	—
INL	DAC integral linearity 1, 6, 7	-1	—	1	LSB	vrefh_cmp = vdda, vrefl_cmp = vss	—
INL	DAC integral linearity 1, 6, 7	-1.5	—	1.5	LSB	vrefh_cmp < vdda	—
DNL	DAC differential linearity 1, 6	-1	—	1	LSB	vrefh_cmp = vdda, vrefl_cmp = vss	—
DNL	DAC differential linearity 1, 6	-1.5	—	1.5	LSB	vrefh_cmp < vdda	—
tDDAC	DAC Initialization and switching settling time	—	—	30	us	—	—
VAIN	Analog input voltage	0	—	VDDA	V	—	—

1. vdda is comparator HV supply and internally shorted to VDD_HV_A pin. vss is comparator ground
2. Difference at input > 200mV
3. Applied +/- (100 mV + VAHYST0/1/2/3 + max. of VAIO) around switch point
4. Applied +/- (30 mV + 2 x VAHYST0/1/2/3 + max. of VAIO) around switch point
5. Applied ± (100 mV + VAHYST0/1/2/3).
6. 1 LSB = (vrefh_cmp - vrefl_cmp) /256. vrefh_cmp and vrefl_cmp are comparator reference high and low
7. Calculation method used: Linear Regression Least Square Method

For Comparator IN signals adjacent to VDD_HV_A/VDD_HV_B/VSS or XTAL/EXTAL or switching pins cross coupling may happen and hence hysteresis settings can be used to obtain the desired Comparator performance. Additionally an external capacitor to ground (1nF) should be used to filter noise on input signal. Also source drive should not be weak (Signal with <50K pull up/down is recommended).

For devices where the VDD_HV_B domain is present, ACOMP0 channels must only be selected/enabled when VDD_HV_A >= VDD_HV_B. These channels must be disabled when VDD_HV_A goes below VDD_HV_B.

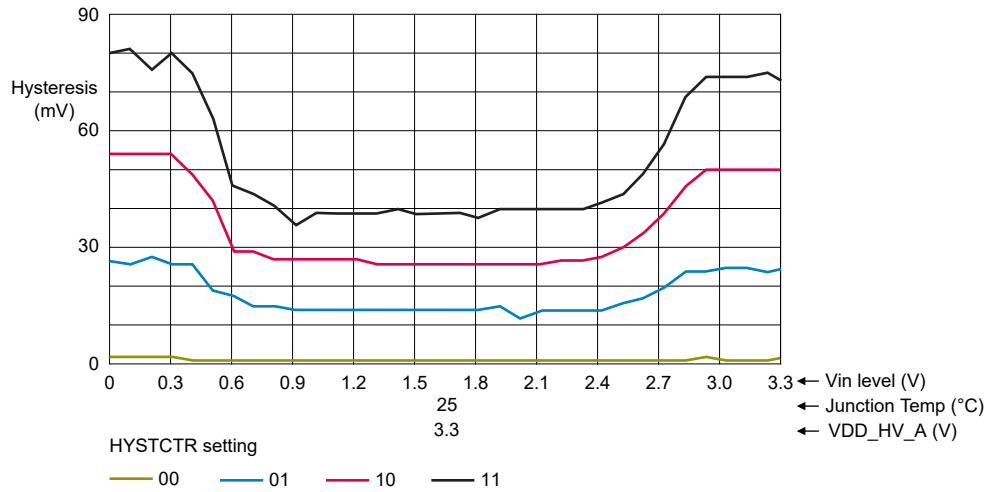

Figure 29. Typical Hysteresis vs Vin level (VDD_HV_A = 3.3 V, High Speed Mode)

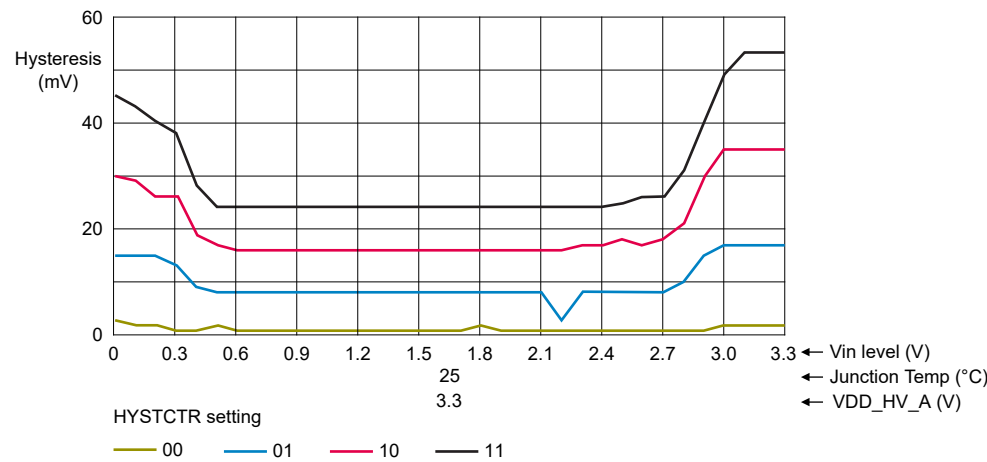

Figure 30. Typical Hysteresis vs Vin level (VDD_HV_A = 3.3 V, Low Speed Mode)

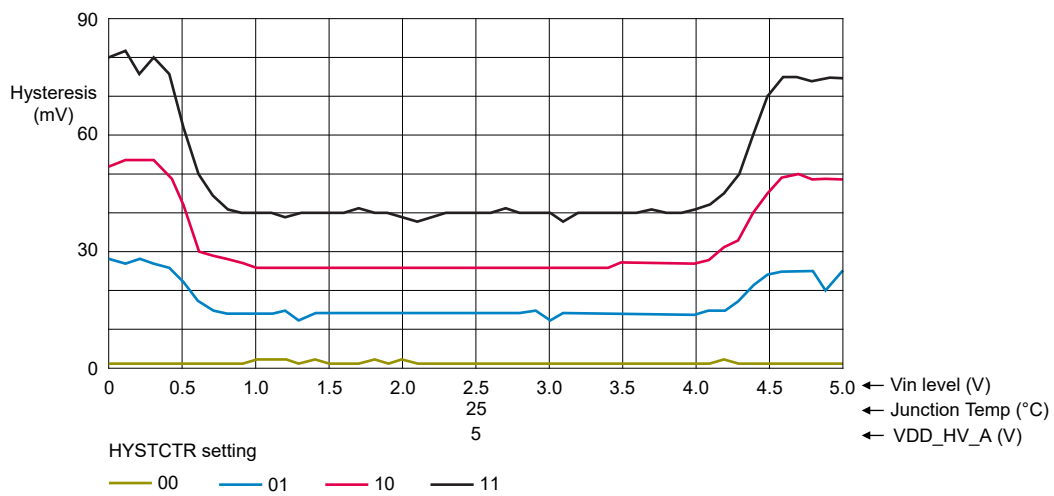
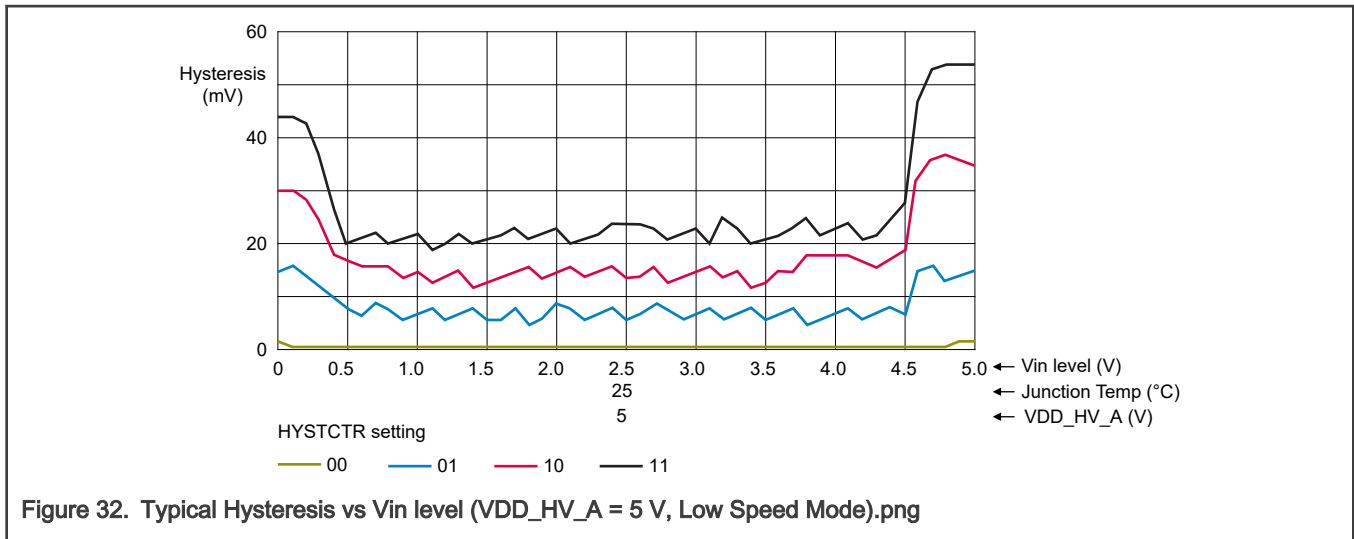

Figure 31. Typical Hysteresis vs Vin level (VDD_HV_A = 5 V, High Speed Mode).png



10.4 Temperature Sensor

The table below gives the specification for the on die temperature sensor.

Table 34. Temperature Sensor

Symbol	Description	Min	Typ	Max	Unit	Condition	Spec Number
TS_TJ	Junction temperature monitoring range	-40	—	150	°C	—	—
TS_IV25	ON state current consumption on V25	—	400	—	µA	ETS_EN=1	—
TS_ACC1	Temperature output error at circuit output (Voltage) ^{1, 2, 3}	-5	0	+5	°C	100 °C < Tj <= 150 °C	—
TS_ACC2	Temperature output error at circuit output (Voltage) ^{1, 2, 3}	-10	0	+10	°C	-40 °C <= Tj <=100 °C	—
TS_TSTART	Circuit start up time	—	4	30	µs	—	—
TS_TADCSA	Required ADC sampling time ¹	1.2	—	—	µs	—	—

1. Required ADC sampling time specified by parameter TS_TADCSA needs to be used at the ADC conversion to guarantee the specified accuracy. A smaller sampling time leads to a less accurate result.
2. Note: The temperature sensor measures the junction temperature Tj at the location where it is placed on die. The local Tj is modulated by current and previous active state of the circuit elements on die.
3. The error caused by ADC conversion and provided temperature calculation formula is not included.

11 Clocking modules

11.1 FIRC

Table 35. FIRC

Symbol	Description	Min	Typ	Max	Unit	Condition	Spec Number
fFIRC	FIRC nominal Frequency	—	48	—	MHz	—	—
FACC	FIRC Frequency deviation across process, voltage, and temperature after trimming	-5	—	5	%	—	—
TSTART	Startup Time ¹	—	10	25	us	—	—

1. Startup time is for reference only.

11.2 SIRC

Table 36. SIRC

Symbol	Description	Min	Typ	Max	Unit	Condition	Spec Number
fSIRC	SIRC nominal Frequency	—	32	—	KHz	—	—
fSIRC_ACC	SIRC Frequency deviation across process, voltage, and temperature after trimming	-10	—	10	%	—	—
TSIRC_start	SIRC Startup Time ¹	—	—	3	ms	—	—
TSIRC_DC	SIRC duty cycle	30	—	70	%	—	—

1. Startup time is for information only.

11.3 PLL

Table 37. PLL

Symbol	Description	Min	Typ	Max	Unit	Condition	Spec Number
FPLL_in	PLL input frequency	8	—	40	MHz	This is the frequency after the Reference Divider within the PLL	—
FPLL_out	PLL output frequency (PLL_PHIn_CLK)	48	—	320	MHz	—	—

Table continues on the next page...

Table 37. PLL (continued)

Symbol	Description	Min	Typ	Max	Unit	Condition	Spec Number
FPLL_vcoRange	VCO Frequency range	640	—	1280	MHz	—	—
FPLL_DS	Modulation Depth (down spread)	-0.5	—	-3	%	—	—
FPLL_FM	Modulation frequency	—	—	32	KHz	—	—
TPLL_start	PLL lock time	—	—	1	ms	—	—
JPLL_cyc	PLL period jitter (pk-pk) ^{1, 2, 3}	—	—	237	ps	FPLL_out = 240MHz, Integer Mode	—
JPLL_cyc	PLL period jitter (pk-pk) ^{1, 2, 3}	—	—	487	ps	FPLL_out = 240MHz, Fractional Mode	—
JPLL_acc	PLL accumulated jitter (pk-pk) ^{1, 2, 3}	—	—	840	ps	FPLL_out = 240MHz, Integer Mode	—
JPLL_acc	PLL accumulated jitter (pk-pk) ^{1, 2, 3}	—	—	1680	ps	FPLL_out = 240MHz, Fractional Mode	—
JPLL_cyc	PLL period jitter (pk-pk) ^{1, 2, 3}	—	—	295	ps	FPLL_out = 160MHz, Integer Mode	—
JPLL_cyc	PLL period jitter (pk-pk) ^{1, 2, 3}	—	—	670	ps	FPLL_out = 160MHz, Fractional Mode	—
JPLL_acc	PLL accumulated jitter (pk-pk) ^{1, 2, 3}	—	—	840	ps	FPLL_out = 160MHz, Integer Mode	—
JPLL_acc	PLL accumulated jitter (pk-pk) ^{1, 2, 3}	—	—	1680	ps	FPLL_out = 160MHz, Fractional Mode	—
JPLL_cyc	PLL period jitter (pk-pk) ^{1, 2, 3}	—	—	353	ps	FPLL_out = 120MHz, Integer Mode	—
JPLL_cyc	PLL period jitter (pk-pk) ^{1, 2, 3}	—	—	853	ps	FPLL_out = 120MHz, Fractional Mode	—
JPLL_acc	PLL accumulated jitter (pk-pk) ^{1, 2, 3}	—	—	840	ps	FPLL_out = 120MHz, Integer Mode	—
JPLL_acc	PLL accumulated jitter (pk-pk) ^{1, 2, 3}	—	—	1680	ps	FPLL_out = 120MHz, Fractional Mode	—

1. For SSCG, jitter due to systematic modulation needs to be added as per applied modulation.
2. Jitter numbers are valid only at IP boundary and does not include any degradation due to IO pad for clock measurement.
3. Jitter numbers calculated by extrapolating RMS jitter numbers to +/- 7 sigma .

11.4 Fast External Oscillator (FXOSC)

Table 38. Fast External Oscillator (FXOSC)

Symbol	Description	Min	Typ	Max	Unit	Condition	Spec Number
FREQ_BYPASS	Input clock frequency in bypass mode ¹	—	—	50	MHz	—	—
TRF_BYPASS	Input clock rise/fall time in bypass mode ¹	—	—	5	ns	—	—
CLKIN_DUTY_BYPASS	Input clock duty cycle in bypass mode ¹	47.5	—	52.5	%	—	—
FXOSC_CLK	output clock frequency in crystal mode	8	—	40	MHz	—	—
TFXOSC	Fxosc start up time (ALC enabled) ²	—	—	2	ms	—	—
IFXOSC	Oscillator Analog circuit supply current, V25 supply	—	—	1	mA	using 8, 16 or 40 MHz crystal	—
GM	Amplifier Transconductance	9.7	—	18.5	mA/V	GM_SEL[3:0] = 4'b1111	—

1. For bypass mode applications, the EXTAL pin should be driven low when FXOSC is in off/disabled state.
2. The startup time specification is valid only when the recommended crystal and load capacitors are used. For higher load capacitances, the actual startup time might be higher.

To ensure stable oscillations, FXOSC incorporates the feedback resistance internally.

Drive level is a crystal specification and if crystal load capacitance is increased beyond the recommended value, it may violate the crystal drive level rating. In such cases, contact NXP sales representative for selecting the correct crystal.

Crystal oscillator circuit provides stable oscillations when $gm_{XOSC} > 5 * gm_{crit}$. The gm_{crit} is defined as:

$$gm_{crit} = 4 * (ESR + RS) * (2\pi F)^2 * (C0 + CL)^2$$

where:

- gm_{XOSC} is the transconductance of the internal oscillator circuit
- ESR is the equivalent series resistance of the external crystal
- RS is the series resistance connected between XTAL pin and external crystal for current limitation
- F is the external crystal oscillation frequency
- C0 is the shunt capacitance of the external crystal
- CL is the external crystal total load capacitance. $CL = Cs + [C1 * C2 / (C1 + C2)]$
- Cs is stray or parasitic capacitance on the pin due to any PCB traces
- C1, C2 external load capacitances on EXTAL and XTAL pins

See manufacture datasheet for external crystal component values

Figure 33. Oscillation build-up equation

NOTE

To improve the FXOSC jitter & duty cycle performance, the functionality of the pin next to the Oscillator (namely, PTE14 in MAXQFP172 and PTE3 in MAXQFP100 package) must be limited to static GPIO operation.

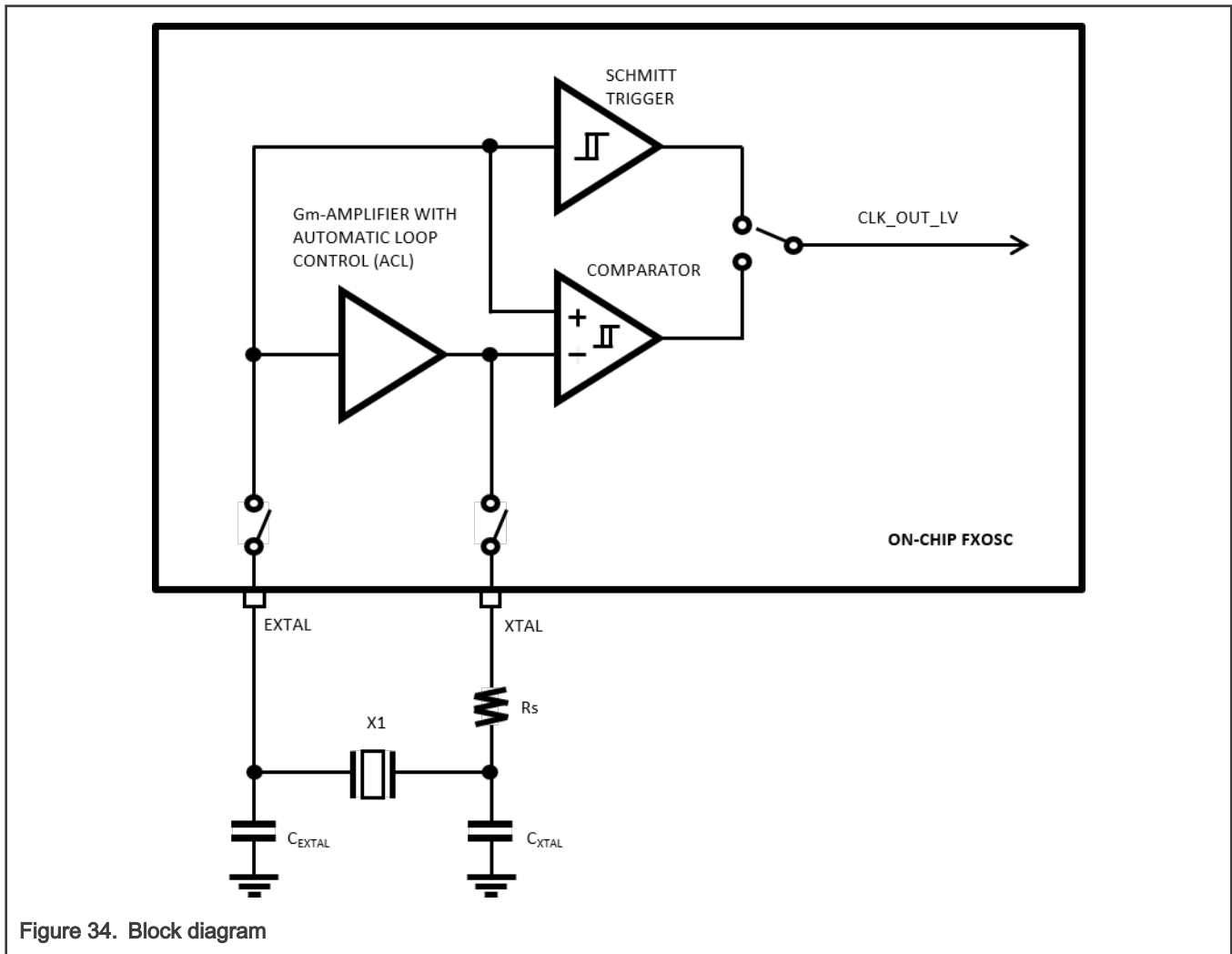

Figure 34. Block diagram

11.5 Slow Crystal Oscillator (SXOSC)

Table 39. Slow Crystal Oscillator (SXOSC)

Symbol	Description	Min	Typ	Max	Unit	Condition	Spec Number
Fsxosc	Oscillator Crystal Frequency ¹	—	32.768	—	KHz	IP in crystal mode	—
Tstart	SXOSC startup time	—	—	2	s	start up time is dependent upon board and crystal model.	—
ISXOSC	Oscillator Analog circuit supply current	—	2.1	—	uA	—	—
gm_sxocs	NMOS Amplifier Transconductance	3	—	40	u A/V	—	—

1. Supports single frequency

12 Communication interfaces

12.1 LPSPI

12.1.1 LPSPI

The Low Power Serial Peripheral Interface (LPSPI) provides a synchronous serial bus with master and slave operations. Many of the transfer attributes are programmable. The following table provides timing characteristics for classic LPSPI timing modes.

1. All timing is shown with respect to 20% VDD_HV_A/B and 80% VDD_HV_A/B thresholds.
2. All measurements are with maximum output load of 30 pF, input transition of 1 ns and pad configured with fastest slew setting (DSE = 1'b1).

Table 40. LPSPI

Symbol	Description	Min	Typ	Max	Unit	Condition	Spec Number
fperiph	Peripheral Frequency ^{1, 2, 3}	—	—	40	MHz	Master	—
fperiph	Peripheral Frequency ^{1, 2, 3}	—	—	40	MHz	Slave	—
fperiph	Peripheral Frequency ^{1, 3, 4}	—	—	80	MHz	Master Loopback	—
fop	Operating frequency	—	—	15	MHz	Slave	1
fop	Operating frequency	—	—	15	MHz	Master	1
fop	Operating frequency ⁵	—	—	10	MHz	Slave_10Mbps	1
fop	Operating frequency ⁵	—	—	10	MHz	Master_10Mbps	1
fop	Operating frequency ^{4, 6}	—	—	20	MHz	Master Loopback	1
tSPSCK	SPSCK period	66	—	—	ns	Slave	2
tSPSCK	SPSCK period	66	—	—	ns	Master	2
tSPSCK	SPSCK period ⁴	50	—	—	ns	Master Loopback	2
tSPSCK	SPSCK period	100	—	—	ns	Master_10Mbps	—
tSPSCK	SPSCK period	100	—	—	ns	Slave_10Mbps	—
tLEAD	Enable lead time (PCS to SPSCK delay) ⁷	—	—	—	ns	Slave	3
tLEAD	Enable lead time (PCS to SPSCK delay) ⁷	30	—	—	ns	Master	3

Table continues on the next page...

Table 40. LPSPI (continued)

Symbol	Description	Min	Typ	Max	Unit	Condition	Spec Number
tLEAD	Enable lead time (PCS to SPSCCK delay) ^{4, 7}	30	—	—	ns	Master Loopback	3
tLAG	Enable lag time (After SPSCCK delay) ⁸	—	—	—	ns	Slave	4
tLAG	Enable lag time (After SPSCCK delay) ⁸	30	—	—	ns	Master	4
tLAG	Enable lag time (After SPSCCK delay) ^{4, 8}	30	—	—	ns	Master Loopback	4
tWSPCK	Clock (SPSCCK) high or low time (SPSCCK duty cycle) ⁹	tSPSCCK/ 2 - 3	—	tSPSCCK/ 2 + 3	ns	Slave	5
tWSPCK	Clock (SPSCCK) high or low time (SPSCCK duty cycle) ⁹	tSPSCCK/ 2 - 3	—	tSPSCCK/ 2 + 3	ns	Master	5
tWSPCK	Clock (SPSCCK) high or low time (SPSCCK duty cycle) ^{4, 9}	tSPSCCK/ 2 - 3	—	tSPSCCK/ 2 + 3	ns	Master Loopback	5
tSU	Data setup time(inputs)	6	—	—	ns	Slave	6
tSU	Data setup time(inputs)	25	—	—	ns	Master	6
tSU	Data setup time(inputs)	5	—	—	ns	Slave_10Mbps	6
tSU	Data setup time(inputs)	36	—	—	ns	Master_10Mbps	6
tSU	Data setup time(inputs) ⁴	6	—	—	ns	Master_Loopback	6
tHO	Data hold time(inputs)	3	—	—	ns	Slave	7
tHO	Data hold time(inputs)	0	—	—	ns	Master	7
tHO	Data hold time(inputs)	4	—	—	ns	Slave_10Mbps	7
tHO	Data hold time(inputs)	0	—	—	ns	Master_10Mbps	7

Table continues on the next page...

Table 40. LPSPI (continued)

Symbol	Description	Min	Typ	Max	Unit	Condition	Spec Number
tHO	Data hold time(inputs) ⁴	3	—	—	ns	Master Loopback	7
tA	Slave access time	—	—	50	ns	Slave	8
tDIS	Slave MISO (SOUT) disable time	—	—	50	ns	Slave	9
tV	Data valid (after SPCK edge)	—	—	26	ns	Slave	10
tV	Data valid (after SPCK edge)	—	—	14	ns	Master	10
tV	Data valid (after SPCK edge)	—	—	36	ns	Slave_10Mbps	10
tV	Data valid (after SPCK edge)	—	—	21	ns	Master_10Mbps	10
tV	Data valid (after SPCK edge) ⁴	—	—	17.5	ns	Master Loopback	10
tHO	Data hold time (outputs)	3	—	—	ns	Slave	11
tHO	Data hold time (outputs)	-8	—	—	ns	Master	11
tHO	Data hold time (outputs)	3	—	—	ns	Slave_10Mbps	11
tHO	Data hold time (outputs)	-15	—	—	ns	Master_10Mbps	11
tHO	Data hold time (outputs) ⁴	-2	—	—	ns	Master Loopback	11
tRI/FI	Rise/Fall time input	—	—	1	ns	Slave	12
tFI/RI	Rise/Fall time input	—	—	1	ns	Master	12
tFI/RI	Rise/Fall time input ⁴	—	—	1	ns	Master Loopback	12
tFO/RO	Rise/Fall time output	—	—	25	ns	Slave	13
tFO/RO	Rise/Fall time output	—	—	25	ns	Master	13
tFO/RO	Rise/Fall time output ⁴	—	—	25	ns	Master Loopback	13

1. $t_{periph} = 1/f_{periph}$
2. For LPSPI0 instance, max. peripheral frequency is equal to AIPS_PLAT_CLK.
3. f_{periph} = LPSPI peripheral clock
4. Master Loopback mode: In this mode LPSPI_SCK clock is delayed for sampling the input data which is enabled by setting LPSPI_CFGR1[SAMPLE] bit as 1.
5. These specifications apply to the SPI operation, as master or slave, at up to 10 Mbps for the combinations not indicated in the table below. Unless otherwise noted, all other 'master' and 'slave' specifications are also applicable in the 10Mbps configurations. See table "LPSPI 20 MHz and 15 MHz Combinations.
6. LPSPI0 support up to 20MHz on fast pin.

7. Minimum configuration value for CR[PCSSCK] field is 3(0x00000011).
8. Minimum configuration value for CCR[SCKPCS] field is 3(0x00000011).
9. While selecting odd dividers, ensure Duty Cycle is meeting this parameter.

f_{periph} = LPSPI peripheral clock

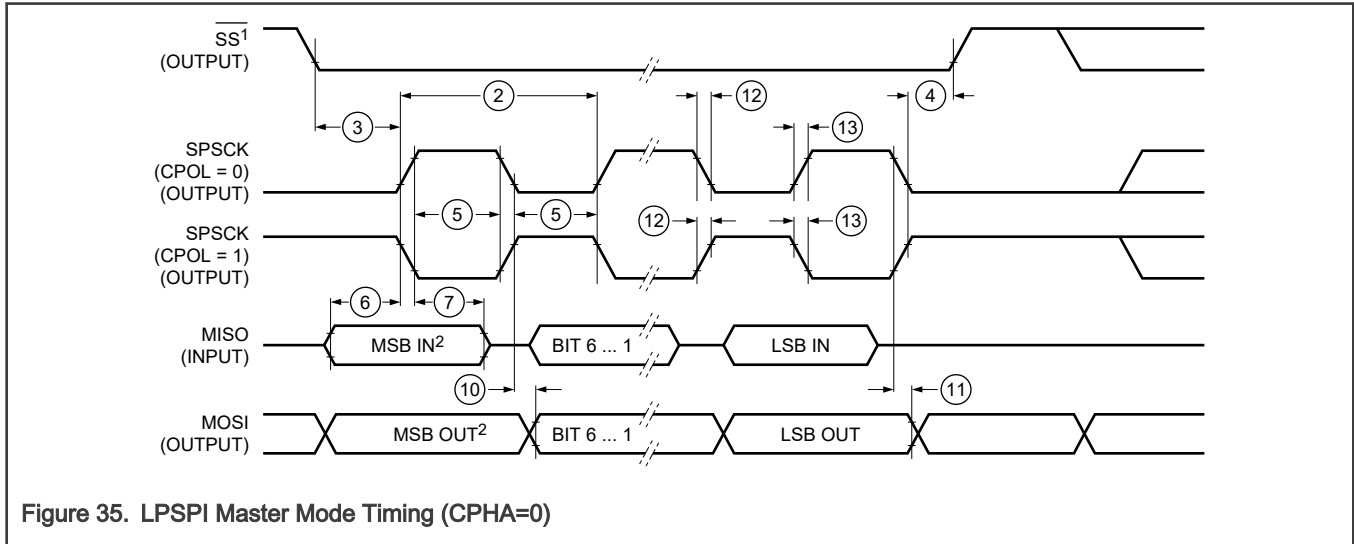

Figure 35. LPSPI Master Mode Timing (CPHA=0)

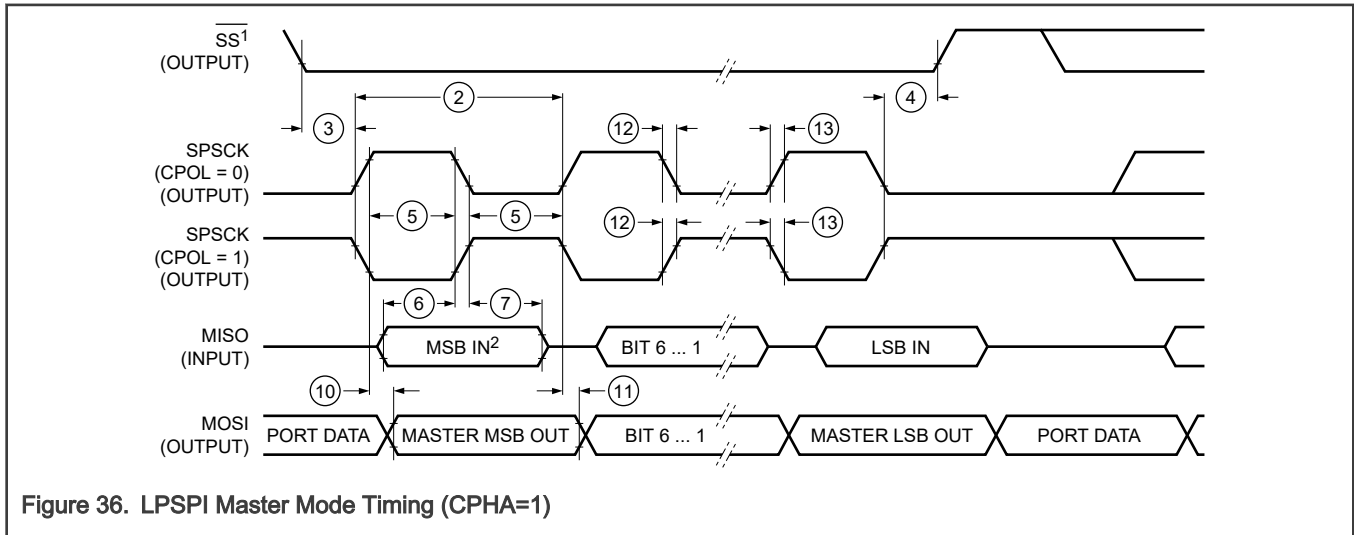
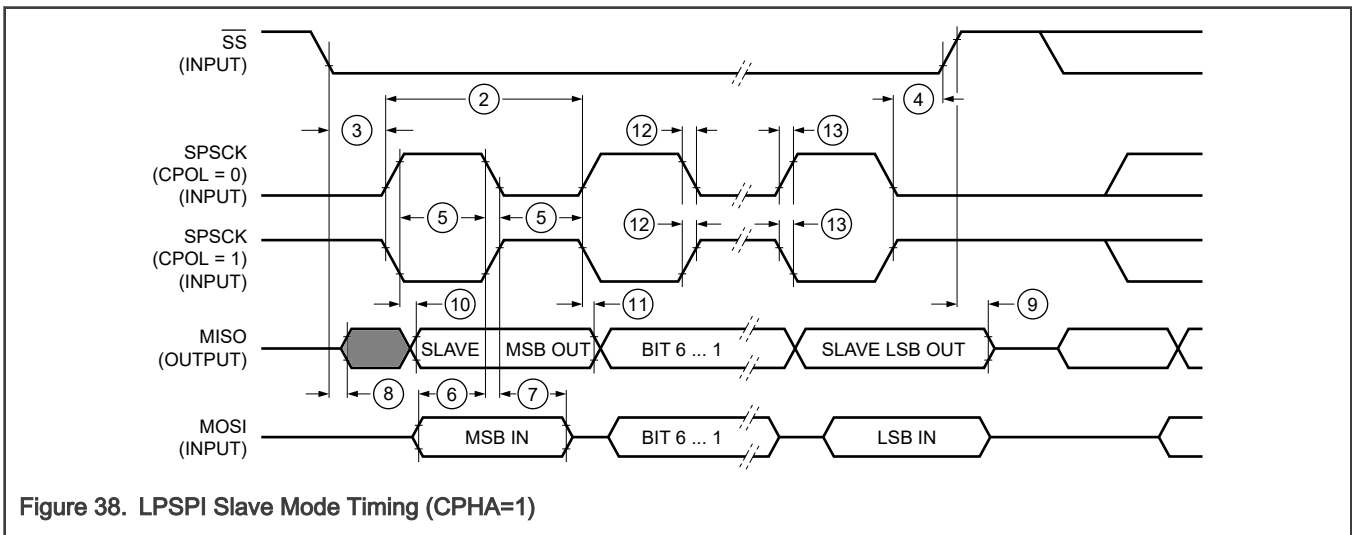
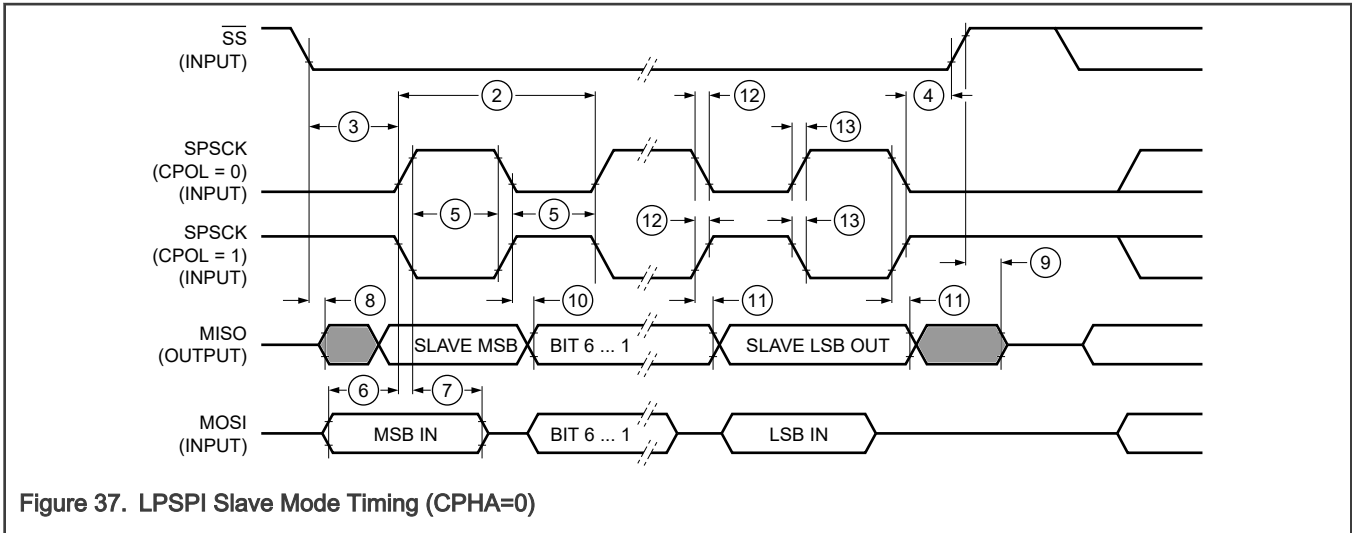

Figure 36. LPSPI Master Mode Timing (CPHA=1)



12.1.2 LPSPi0 20 MHz and 15 MHz Combinations

Table 41. LPSPi0 20 MHz and 15 MHz Combinations

PORT	S32K344 PAD TYPE	SPI Signal	20Mbps (In loopback mode only)	15 Mbps
PTB1	GPIO-Standard-plus	LPSPi0_SOUT		LPSPi0_SOUT
PTB0	GPIO-Standard-plus	LPSPi0_PCS0		LPSPi0_PCS0
PTC9	GPIO-Standard-plus	LPSPi0_SIN		LPSPi0_SIN
PTC8	GPIO-Standard-plus	LPSPi0_SCK		LPSPi0_SCK
PTD6	GPIO-Medium	LPSPi0_PCS0	LPSPi0_PCS0	
PTD5	GPIO-Medium	LPSPi0_PCS1	LPSPi0_PCS1	
PTD12	GPIO-FAST	LPSPi0_SOUT	LPSPi0_SOUT	
PTD11	GPIO-FAST	LPSPi0_SCK	LPSPi0_SCK	
PTD10	GPIO-FAST	LPSPi0_SIN	LPSPi0_SIN	

NOTE

Trace length should not exceed 11 inches for SCK pad when used in Master loopback mode.

12.2 I²C

See [I/O parameters](#) for I²C specification.

"For supported baud rate see section 'Chip-specific LPI2C information' of the Reference Manual."

12.3 I3C Push-Pull Timing Parameters for SDR Mode

I3C interface is not supported on GPIO-Standard-plus pad type for 5 V operation. Measurements are with maximum output load of 30 pF, input transition of 1 ns. GPIO-Standard-plus pad configured with DSE = 1'b1 and GPIO-Medium pad with DSE = 1'b1 and SRE = 1'b1. SCL, SDA and PUR combination should be of same pad type. For e.g. I3C medium Data Pads to be used with I3C Medium Clock and PUR Pads Only. I3C Standard plus Data Pads to be used with I3C standard plus Clock and PUR pads only.

Table 42. I3C Push-Pull Timing Parameters for SDR Mode

Symbol	Description	Min	Typ	Max	Unit	Condition	Spec Number
fSCL	SCL Clock Frequency	0.01	12.5	12.9	MHz	$F_{SCL} = 1 / (t_{DIG_L} + t_{DIG_H})$	—
tDIG_L	SCL Clock Low Period ^{1, 2}	32	—	—	ns	—	—
tDIG_H	SCL Clock High Period ¹	32	—	—	ns	—	—
tSCO	Clock in to Data Out for Slave ^{3, 4}	—	—	12	ns	—	—
tCR	SCL Clock Rise Time ⁵	—	—	150e06 * 1 / fSCL (capped at 60)	ns	—	—
tCF	SCL Clock Fall Time ⁵	—	—	150e06 * 1 / fSCL (capped at 60)	ns	—	—
tHD_PP	SDA Signal Data Hold in Push-Pull Mode, Slave ⁶	0	—	—	—	Applicable for slave and master loopback modes	—
tSU_PP	SDA Signal Data Setup in Push-Pull Mode	3	—	N/A	ns	Applicable for slave and master loopback modes.	—

- tDIG_L and tDIG_H are the clock Low and High periods as seen at the receiver end of the I3C Bus using VIL and VIH (see Figure 30)
- As both edges are used, the hold time needs to be satisfied for the respective edges; i.e., tCF + 3 for falling edge clocks, and tCR + 3 for rising edge clocks.
- Pad delay based on 90 Ω / 4 mA driver and 50 pF load. Note that Master may be a Slave in a multi-Master system, and thus shall also adhere to this requirement
- Devices with more than 12ns of tSCO delay shall set the limitation bit in the BCR, and shall support the GETMXDS CCC to allow the Master to read this value and adjust computations accordingly. For purposes of system design and test conformance, this parameter should be considered together with pad delay, bus capacitance, propagation delay, and clock triggering points.

5. The clock maximum rise/fall time is capped at 60 ns. For lower frequency rise and fall the maximum value is limited at 60 ns, and is not dependent upon the clock frequency.
6. t_{HD_PP} is a Hold time parameter for Push-Pull Mode that has a different value for Master mode vs. Slave mode. In SDR Mode the Hold time parameter is referred to as t_{HD_SDR} .

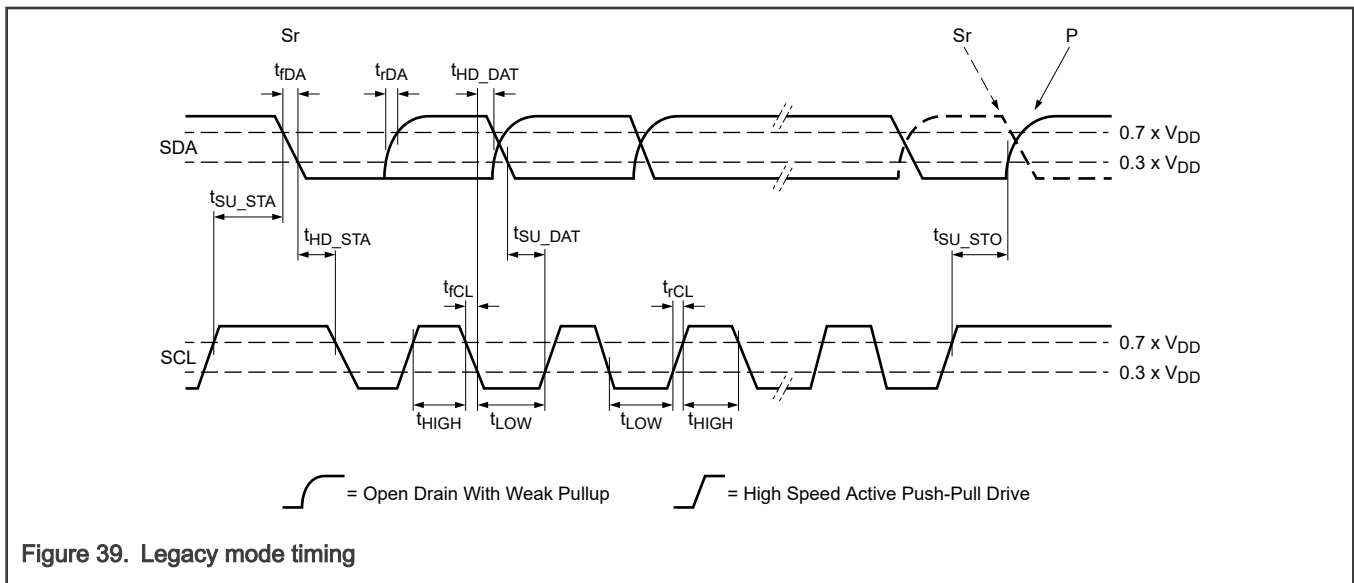

Figure 39. Legacy mode timing

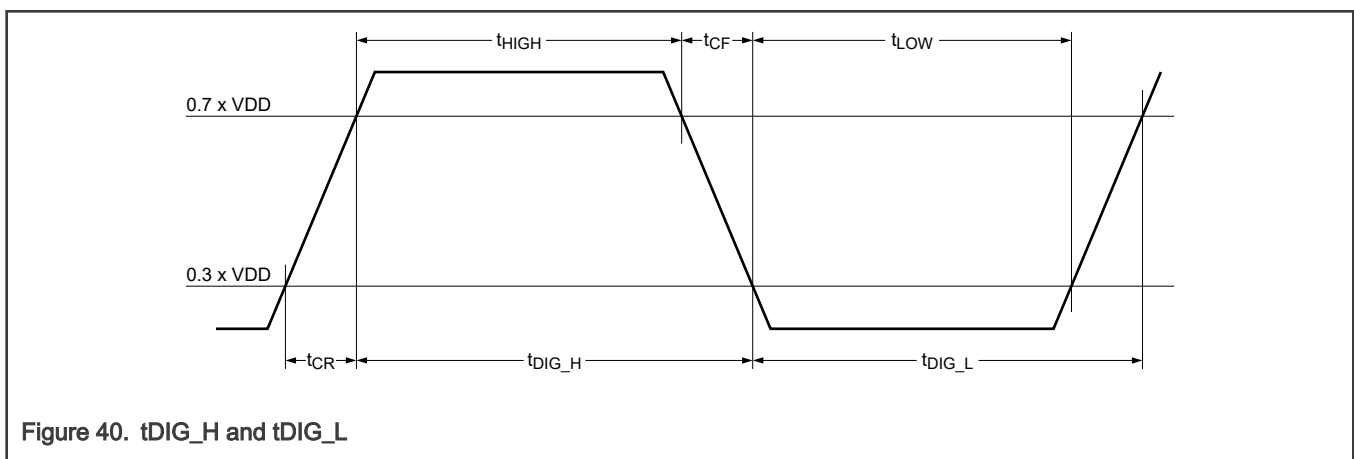

Figure 40. t_{DIG_H} and t_{DIG_L}

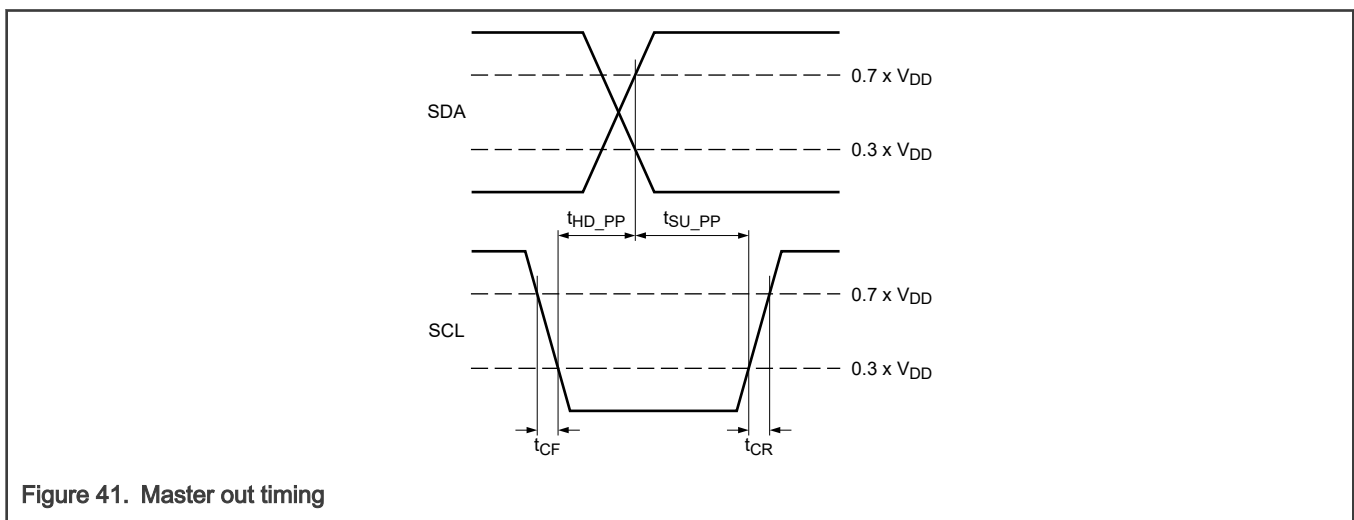
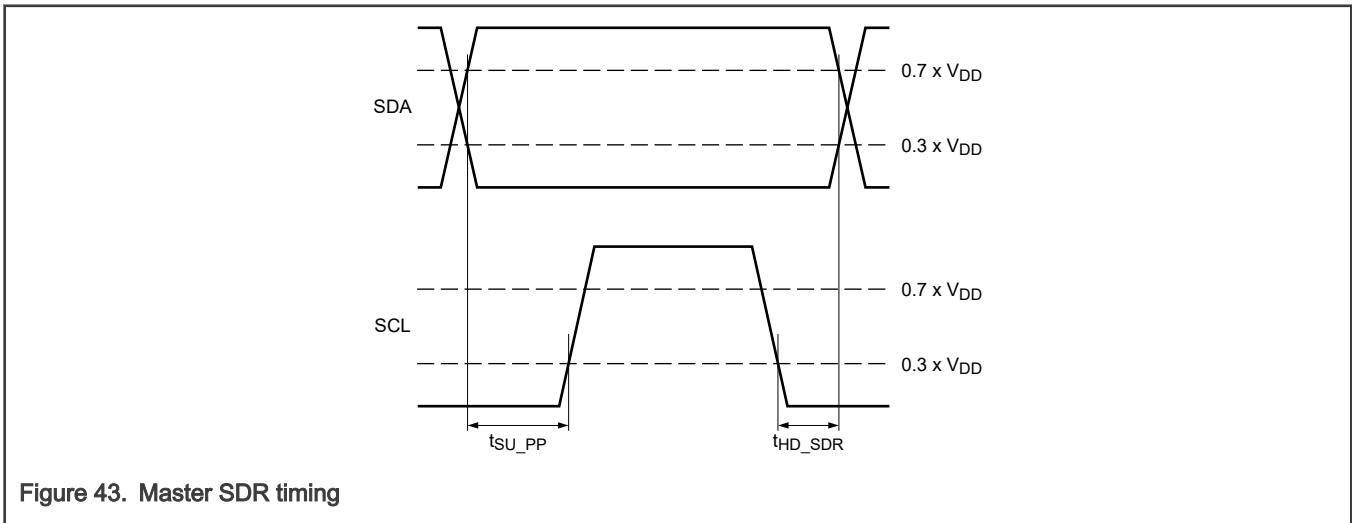
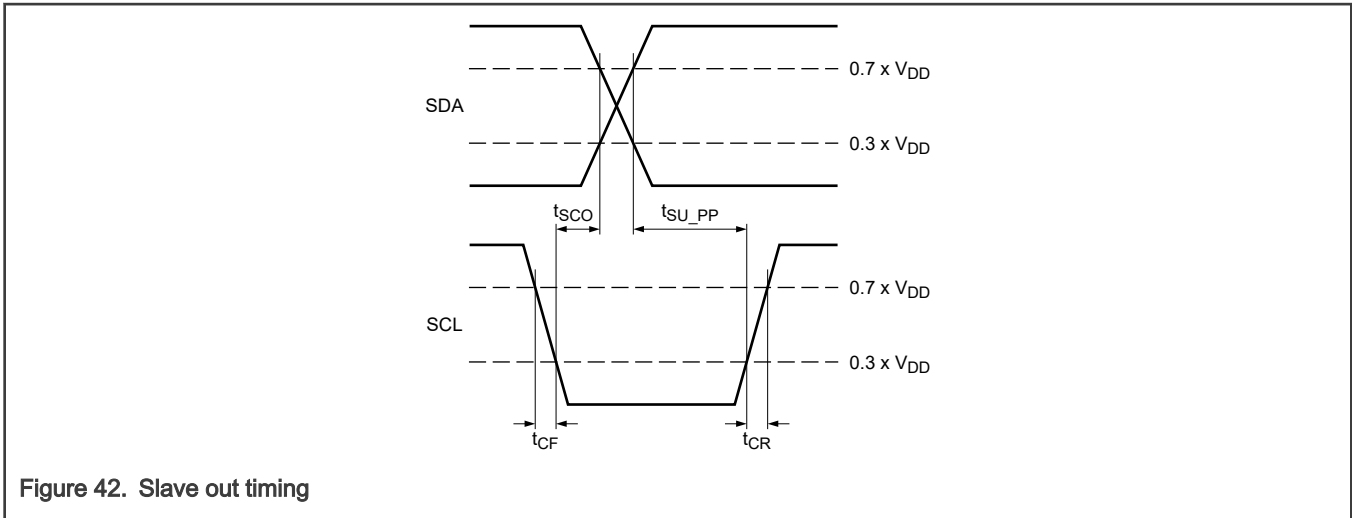

Figure 41. Master out timing



12.4 FlexCAN characteristics

See [I/O parameters](#) for FlexCAN specification.

"For supported baud rate, see section 'Protocol timing' of the Reference Manual."

12.5 SAI electrical specifications

12.5.1 SAI Electrical Characteristics, Slave Mode

The following table describes the SAI electrical characteristics. Measurements are with maximum output load of 30pF, input transition of 1ns and pad configured with DSE = 1'b1 and SRE = 1'b0. I/O operating voltage ranges from 2.97 V to 3.63 V.

Table 43. SAI Electrical Characteristics, Slave Mode

Symbol	Description	Min	Typ	Max	Unit	Condition	Spec Number
S13	SAI_BCLK cycle time (input)	80	—	—	ns	—	—

Table continues on the next page...

Table 43. SAI Electrical Characteristics, Slave Mode (continued)

Symbol	Description	Min	Typ	Max	Unit	Condition	Spec Number
S14	SAI_BCLK pulse width high/low (input) ¹	45	—	55	%	—	—
S15	SAI_RXD input setup before SAI_BCLK	8	—	—	ns	—	—
S16	SAI_RXD input hold after SAI_BCLK	2	—	—	ns	—	—
S17	SAI_BCLK to SAI_TXD output valid	—	—	28	ns	—	—
S18	SAI_BCLK to SAI_TXD output invalid	0	—	—	ns	—	—
S19	SAI_FS input setup before SAI_BCLK	8	—	—	ns	—	—
S20	SAI_FS input hold after SAI_BCLK	2	—	—	ns	—	—
S21	SAI_BCLK to SAI_FS output valid	—	—	28	ns	—	—
S22	SAI_BCLK to SAI_FS output invalid	0	—	—	ns	—	—

1. The slave mode parameters (S15 - S22) assume 50% duty cycle on SAI_BCLK input. Any change in SAI_BCLK duty cycle input must be taken care during the board design or by the master timing.

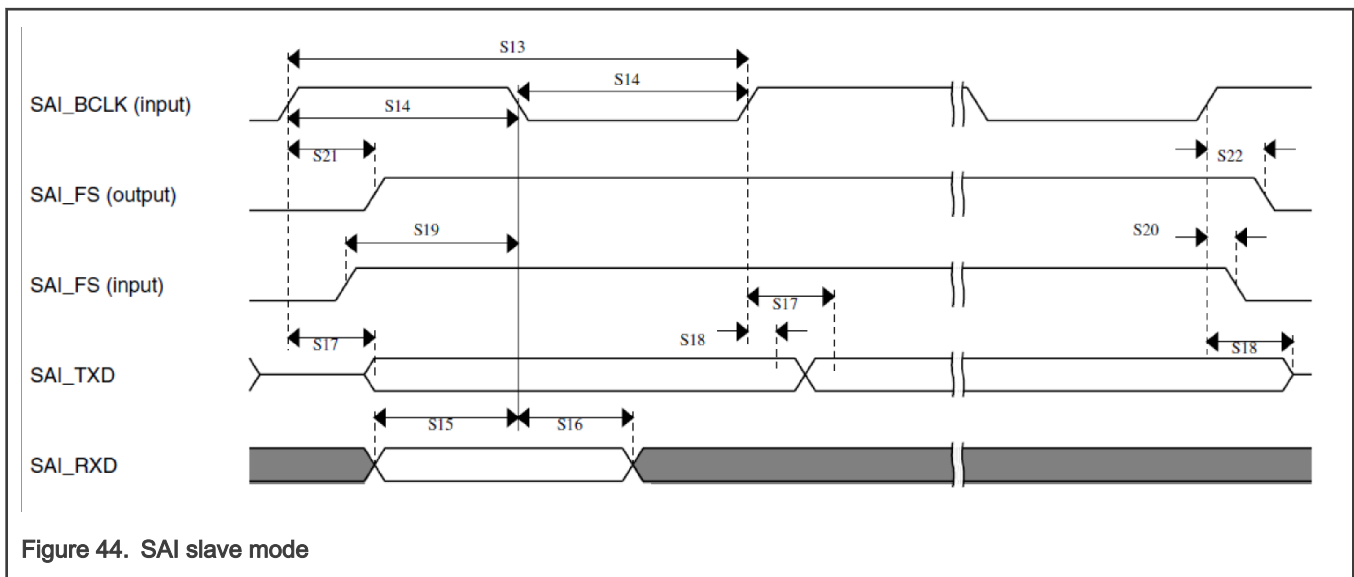

Figure 44. SAI slave mode

12.5.2 SAI Electrical Characteristics, Master Mode

The following table describes the SAI electrical characteristics. Measurements are with maximum output load of 30pF, input transition of 1ns and pad configured with DSE = 1'b1 and SRE = 1'b0. I/O operating voltage ranges from 2.97 V to 3.63 V.

Table 44. SAI Electrical Characteristics, Master Mode

Symbol	Description	Min	Typ	Max	Unit	Condition	Spec Number
S1	SAI_MCLK cycle time	40	—	—	ns	—	—
S2	SAI_MCLK pulse width high/low	45	—	55	%	—	—
S3	SAI_BCLK cycle time	80	—	—	ns	—	—
S4	SAI_BCLK pulse width high/low	45	—	55	%	—	—
S5	SAI_RXD input setup before SAI_BCLK	28	—	—	ns	—	—
S6	SAI_RXD input hold after SAI_BCLK	0	—	—	ns	—	—
S7	SAI_BCLK to SAI_TXD output valid	—	—	8	ns	—	—
S8	SAI_BCLK to SAI_TXD output invalid	-2	—	—	ns	—	—
S9	SAI_FS input setup before SAI_BCLK	28	—	—	ns	—	—
S10	SAI_FS input hold after SAI_BCLK	0	—	—	ns	—	—
S11	SAI_BCLK to SAI_FS output valid	—	—	8	ns	—	—
S12	SAI_BCLK to SAI_FS output invalid	-2	—	—	ns	—	—

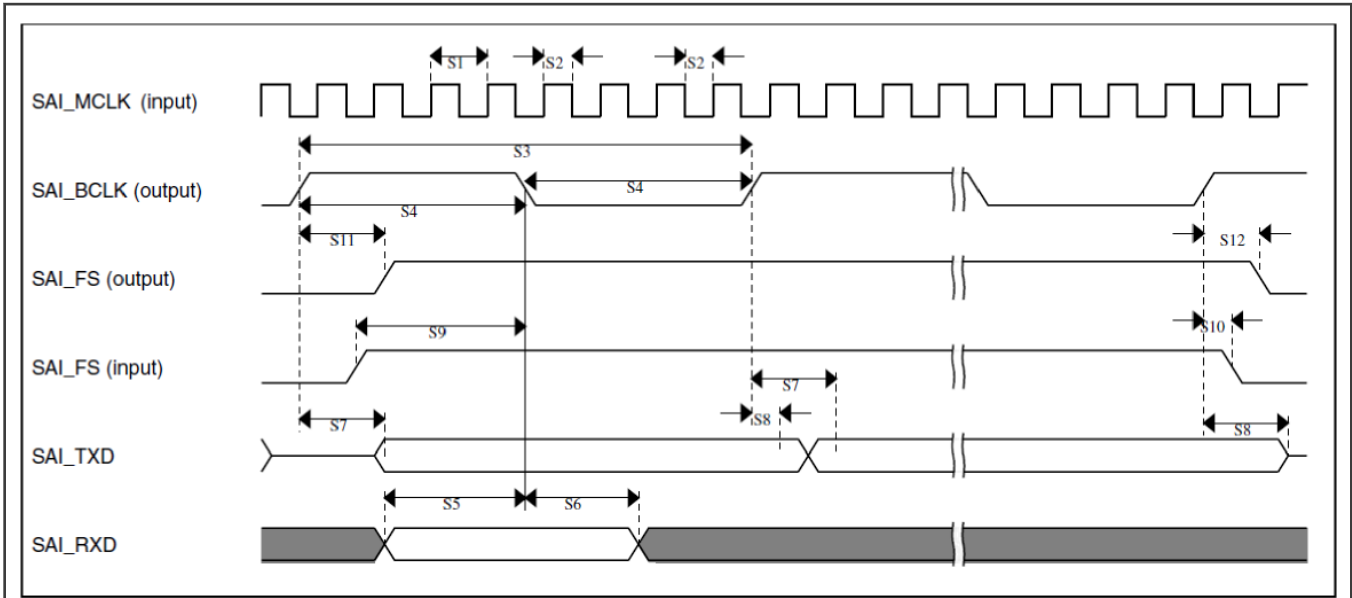

Figure 45. SAI master mode

12.6 Ethernet characteristics

12.6.1 Ethernet MII (100 Mbps)

The following timing specs are defined at the device I/O pin and must be translated appropriately to arrive at timing specs/ constraints for the physical interface. Measurements are with maximum output load of 25pF, input transition of 1ns and pad configured with DSE = 1'b1 and SRE = 1'b0. I/O operating voltage ranges from 2.97 V to 3.63 V.

Table 45. Ethernet MII (100 Mbps)

Symbol	Description	Min	Typ	Max	Unit	Condition	Spec Number
—	RXCLK frequency	—	—	25	MHz	—	—
MII1	RXCLK pulse width high	35	—	65	%RXCLK period	—	—
MII2	RXCLK pulse width low	35	—	65	%RXCLK period	—	—
MII3	RXD[3:0], RXDV, RXER to RXCLK setup	5	—	—	ns	—	—
MII4	RXCLK to RXD[3:0], RXDV, RXER hold	5	—	—	ns	—	—
tCYC_TX	TXCLK frequency	—	25	—	MHz	—	—
MII5	TXCLK pulse width high	35	—	65	%TXCLK period	—	—
MII6	TXCLK pulse width low	35	—	65	%TXCLK period	—	—

Table continues on the next page...

Table 45. Ethernet MII (100 Mbps) (continued)

Symbol	Description	Min	Typ	Max	Unit	Condition	Spec Number
MII7	TXCLK to TXD[3:0], TXEN, TXER invalid	2	—	—	ns	—	—
MII8	TXCLK to TXD[3:0], TXEN, TXER valid	—	—	25	ns	—	—

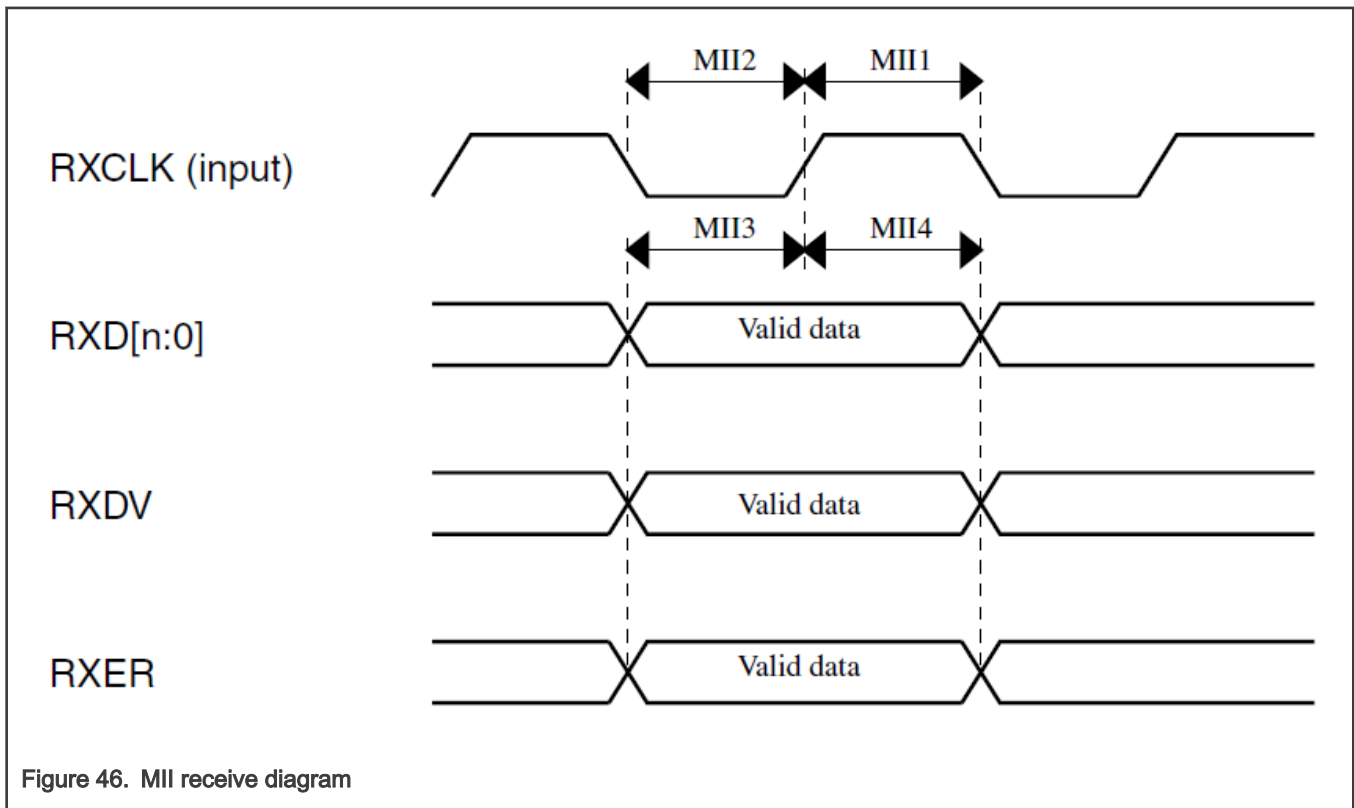

Figure 46. MII receive diagram

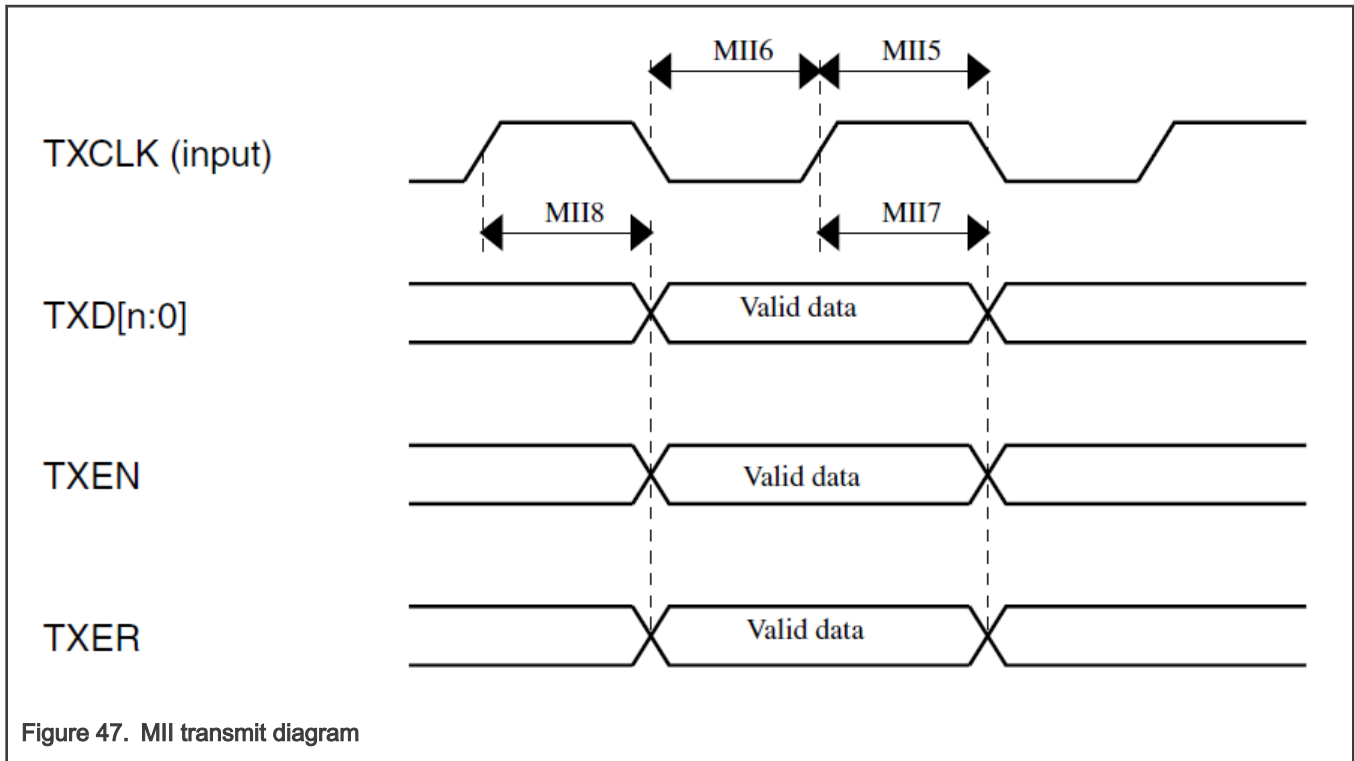

Figure 47. MII transmit diagram

12.6.2 Ethernet MII (200 Mbps)

The following timing specs are defined at the device I/O pin and must be translated appropriately to arrive at timing specs/ constraints for the physical interface. Measurements are with maximum output load of 25pF, input transition of 1ns and pad configured with DSE = 1'b1 and SRE = 1'b0. I/O operating voltage ranges from 2.97 V to 3.63 V.

Table 46. Ethernet MII (200 Mbps)

Symbol	Description	Min	Typ	Max	Unit	Condition	Spec Number
—	RXCLK frequency	—	—	50	MHz	—	—
MII1	RXCLK pulse width high	35	—	65	% RXCLK period	—	—
MII2	RXCLK pulse width low	35	—	65	% RXCLK period	—	—
MII3	RXD[3:0], RXDV, RXER to RXCLK setup time	4	—	—	ns	—	—
MII4	RXCLK to RXD[3:0], RXDV, RXER hold time	2	—	—	ns	—	—
—	TXCLK frequency	—	—	50	MHz	—	—

Table continues on the next page...

Table 46. Ethernet MII (200 Mbps) (continued)

Symbol	Description	Min	Typ	Max	Unit	Condition	Spec Number
MII5	TXCLK pulse width high	35	—	65	% TXCLK period	—	—
MII6	TXCLK pulse width low	35	—	65	% TXCLK period	—	—
MII7	TXCLK to TXD[3:0], TXDV, TXER invalid	2	—	—	ns	—	—
MII8	TXCLK to TXD[3:0], TXDV, TXER valid	—	—	15	ns	—	—

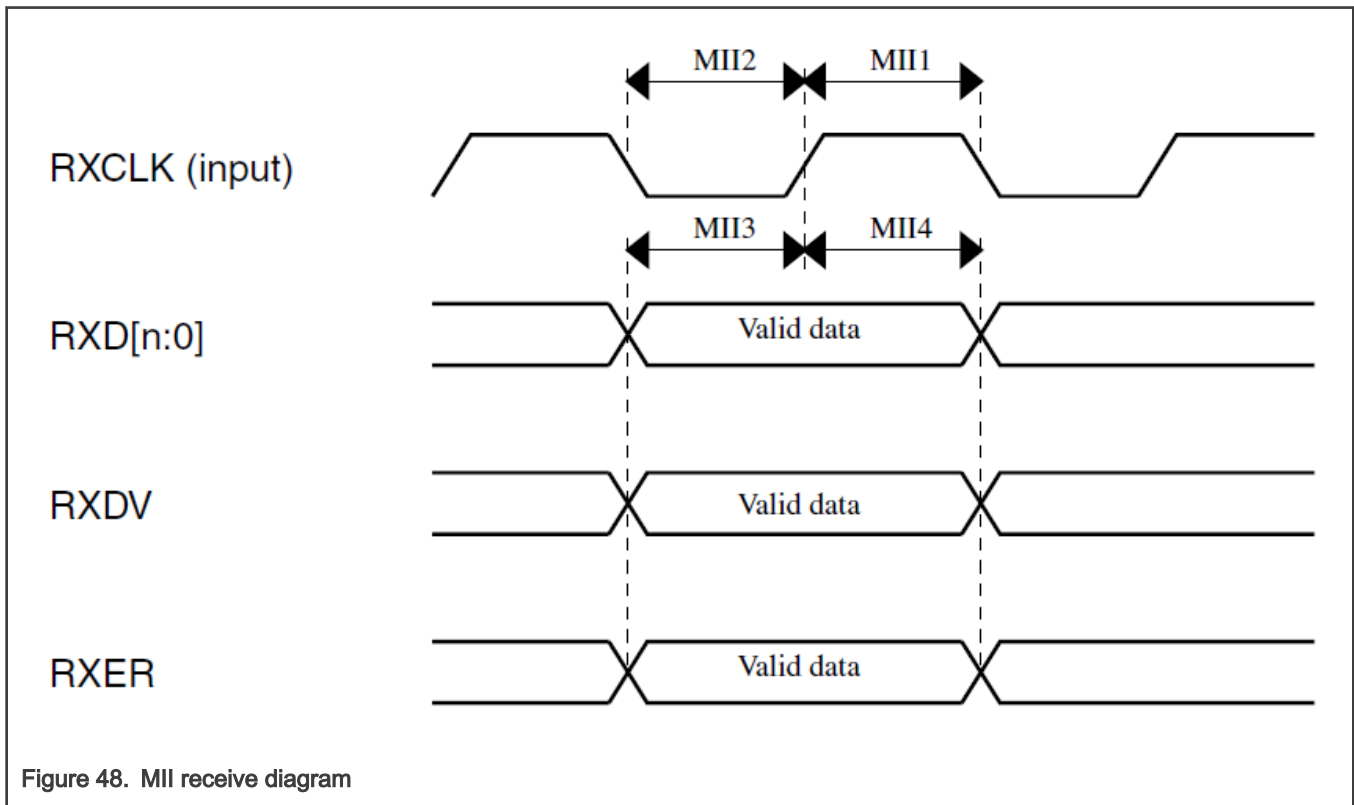

Figure 48. MII receive diagram

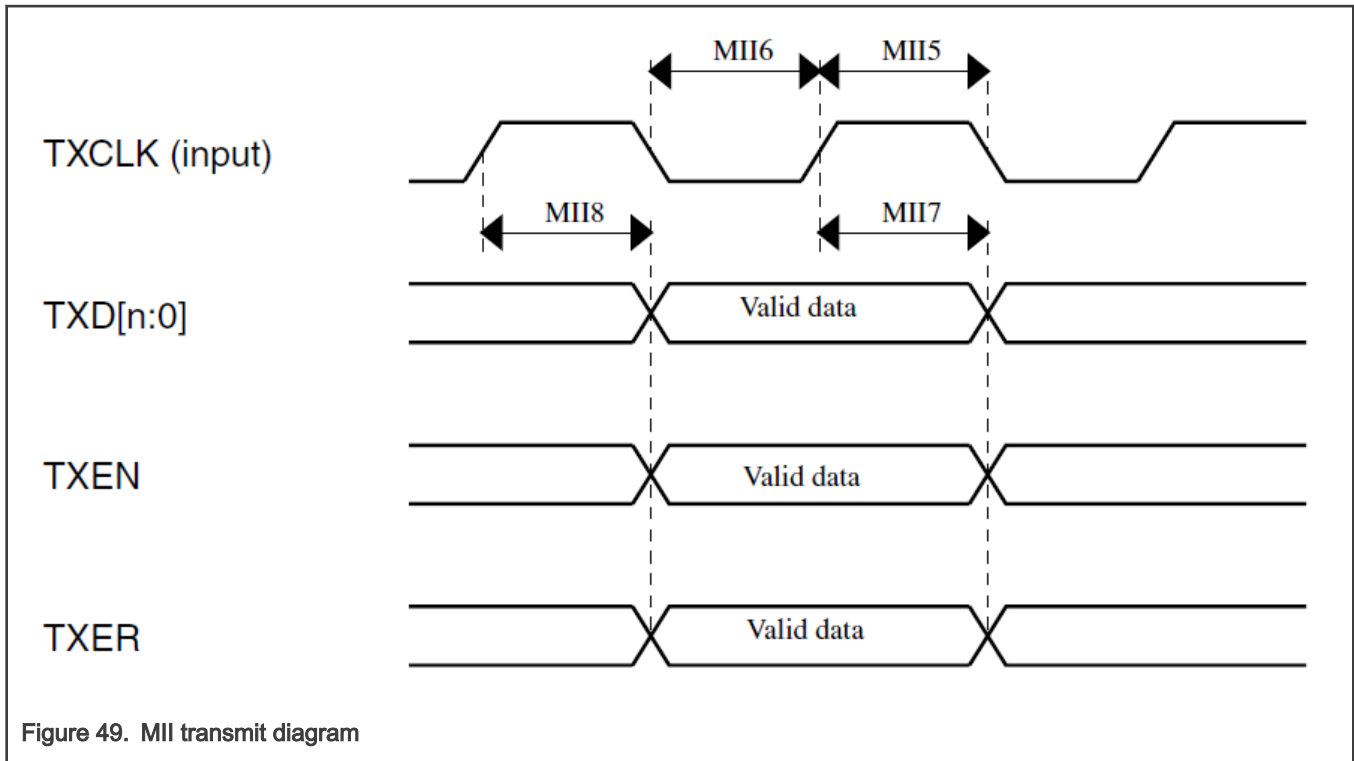

Figure 49. MII transmit diagram

12.6.3 Ethernet RMII

The following timing specs are defined at the device I/O pin and must be translated appropriately to arrive at timing specs/ constraints for the physical interface. Measurements are with maximum output load of 25pF, input transition of 1ns and pad configured with DSE = 1'b1 and SRE = 1'b0. I/O operating voltage ranges from 2.97 V to 3.63 V.

Table 47. Ethernet RMII

Symbol	Description	Min	Typ	Max	Unit	Condition	Spec Number
—	RMII input clock frequency (RMII_CLK)	—	—	50	MHz	—	—
RMII1, RMII5	RMII_CLK pulse width high	35	—	65	%RMII_CLK period	—	—
RMII2, RMII6	RMII_CLK pulse width low	35	—	65	%RMII_CLK period	—	—
RMII3	RXD[1:0], CRS_DV, RXER to RMII_CLK setup	4	—	—	ns	—	—
RMII4	RMII_CLK to RXD[1:0], CRS_DV, RXER hold	2	—	—	ns	—	—
RMII8	RMII_CLK to TXD[1:0], TXEN data valid	—	—	15	ns	—	—

Table continues on the next page...

Table 47. Ethernet RMI (continued)

Symbol	Description	Min	Typ	Max	Unit	Condition	Spec Number
RMII7	RMII_CLK to TXD[1:0], TXEN data invalid	2	—	—	ns	—	—

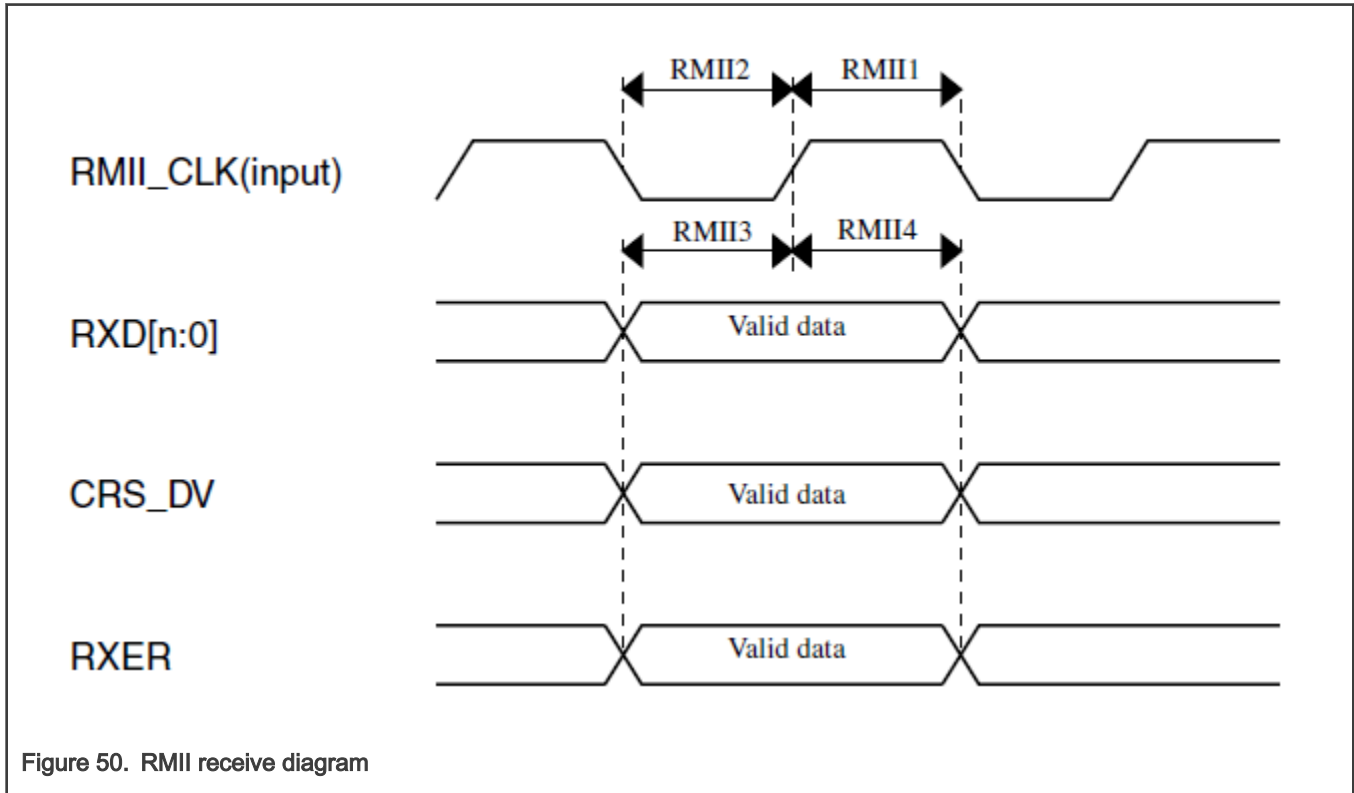

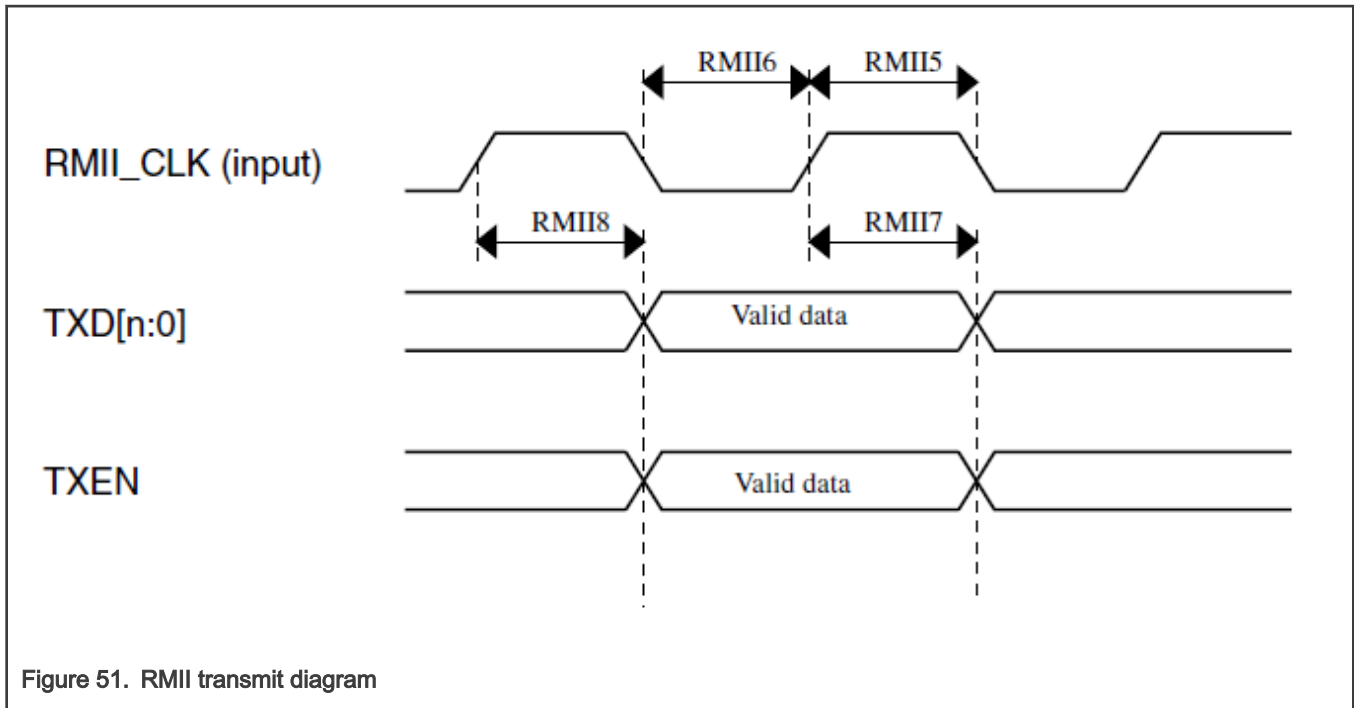

Figure 51. RGMII transmit diagram

12.6.4 Ethernet RGMII

Table 48. Ethernet RGMII

Symbol	Description	Min	Typ	Max	Unit	Condition	Spec Number
Tcyc	Clock cycle duration ^{1, 2}	7.2	—	8.8	ns	SRC = 0	—
TskewT	Data to clock output skew (at transmitter) ²	-500	—	500	ps	SRC=0	—
TskewRi	Data to clock input skew (at receiver) ²	1	—	2.6	ns	SRC=0	—
TskewRo	Data to clock output skew (at receiver) ²	-650	—	650	ps	SRC=0	—
Duty_G	Clock duty cycle for Gigabit ²	45	—	55	%	SRC=0	—
Duty_T	Clock duty cycle for 10/100T ²	40	—	60	%	SRC=0	—
Tr	Output rise time ³	—	—	1	ns	SRC=0	—
Tf	Output fall time ³	—	—	1	ns	SRC=0	—

- For 10 Mbps and 100 Mbps, Tcyc will scale to 400 ns ±40 ns and 40 ns ±4 ns respectively.
- RGMII timing specifications is valid for 3.3V nominal I/O pad supply voltage.
- Output timing valid for maximum external load CL = 13.5pF, which is assumed to be a 5pF load at the end of a 50ohm, un-terminated, 2.5 inch microstrip trace on standard FR4 (1.5pF/inch). For best signal integrity, the series resistance of the transmission line should be matched closely to the selected RDSON of the I/O pad output driver.”

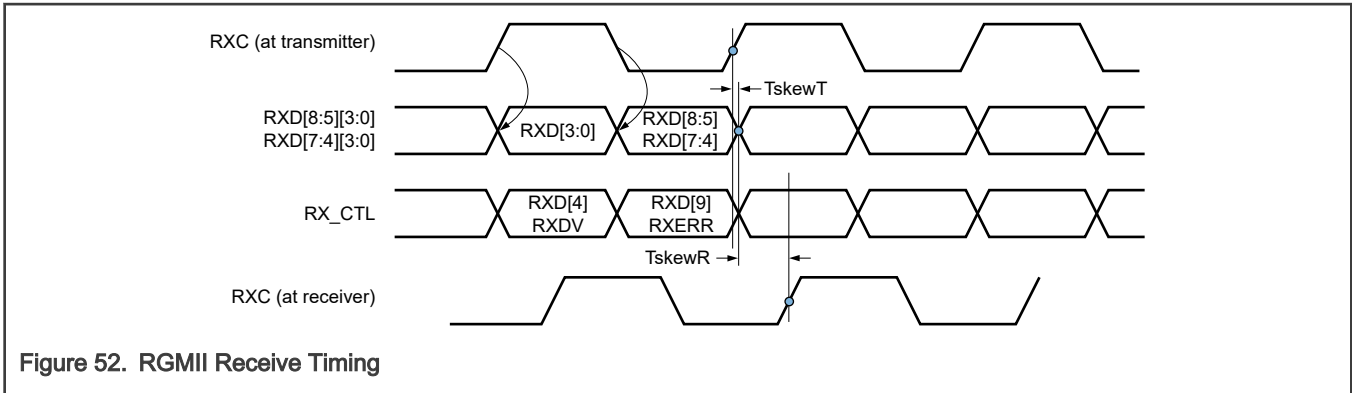

Figure 52. RGMII Receive Timing

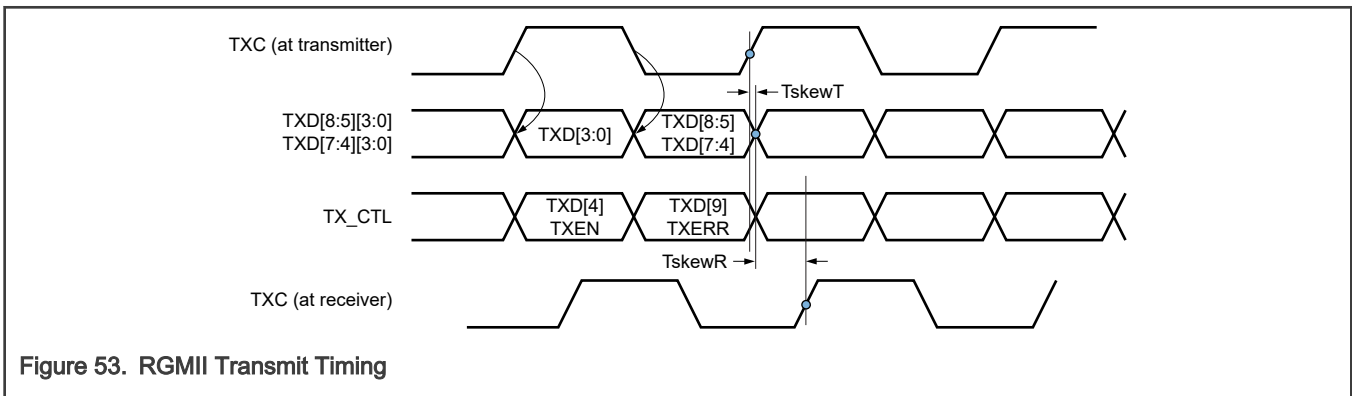

Figure 53. RGMII Transmit Timing

12.6.5 MDIO timing specifications

The following table describes the MDIO electrical characteristics. Measurements are with maximum output load of 25 pF, input transition of 1 ns and pad configured with fastest slew settings (DSE = 1'b1 and SRE = 1'b0). I/O operating voltage ranges from 2.97 V to 3.63 V. MDIO pin must have external Pull-up.

Table 49. MDIO timing specifications

Symbol	Description	Min	Typ	Max	Unit	Condition	Spec Number
—	MDC clock frequency	—	—	2.5	MHz	—	—
MDC1	MDC pulse width high	40	—	60	%MDC period	—	MDC1
MDC2	MDC pulse width low	40	—	60	%MDC period	—	MDC2
MDC5	MDC falling edge to MDIO output valid(maximum propagation delay)	—	—	25	ns	—	MDC5
MDC6	MDC falling edge to MDIO output invalid(minimum propagation delay)	-10	—	—	ns	—	MDC6

Table continues on the next page...

Table 49. MDIO timing specifications (continued)

Symbol	Description	Min	Typ	Max	Unit	Condition	Spec Number
MDC3	MDIO (input) to MDC rising edge setup time	25	—	—	ns	—	MDC3
MDC4	MDIO (input) to MDC rising edge hold time	0	—	—	ns	—	MDC4

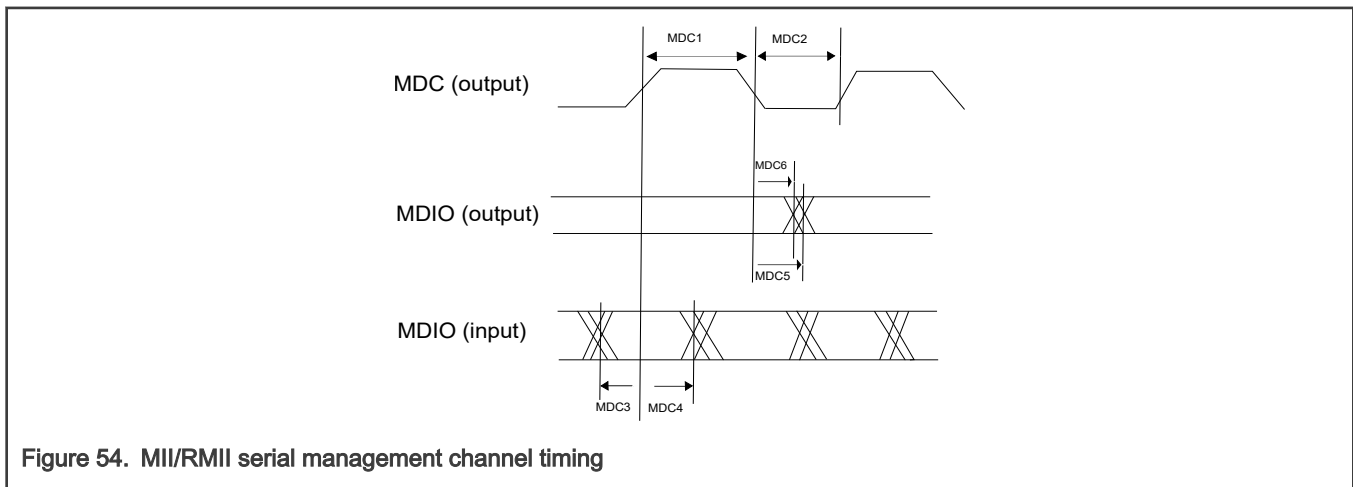

Figure 54. MII/RMII serial management channel timing

12.7 QuadSPI

12.7.1 QuadSPI Quad 3.3V SDR 120MHz

The following table describes the QuadSPI electrical characteristics. Measurements are with maximum output load of 25pF, input transition of 1ns and pads configured with DSE = 1'b1 and SRE = 1'b0. I/O operating voltage ranges from 2.97V to 3.63V. QuadSPI trace length should be less than or equal to 2 inches. For Single and Dual IO modes of operation if external device doesn't have pull-up feature, then external pull-up must be added at board level for unused device pins. With external pull-up, performance of the interface may degrade in Quad IO mode based on load associated with external pull-up. QuadSPI support delay chain upto length 16, wherein delay length of low-frequency segment is 16 and length of high-frequency segment is 0. See the device Reference Manual for register and bit descriptions.

Program register value QuadSPI_FLSHCR[TCSS] = 4'h3.

Program register value QuadSPI_FLSHCR[TCSH] = 4'h3.

Program register value QuadSPI_DLLCRA[SLV_FINE_OFFSET] to 4'b0001.

Table 50. QuadSPI Quad 3.3V SDR 120MHz

Symbol	Description	Min	Typ	Max	Unit	Condition	Spec Number
fSCK	SCK clock frequency ¹	—	—	120	MHz	Pad Loopback	—
fSCK	SCK clock frequency ¹	—	—	60	MHz	Internal Loopback	—

Table continues on the next page...

Table 50. QuadSPI Quad 3.3V SDR 120MHz (continued)

Symbol	Description	Min	Typ	Max	Unit	Condition	Spec Number
tSCK	SCK clock period	1/fSCK	—	—	ns	Pad Loopback	—
tSCK	SCK clock period	1/fSCK	—	—	ns	Internal Loopback	—
tSDC	SCK duty cycle ²	45	—	55	%	Internal Loopback	—
tSDC	SCK duty cycle ²	45	—	55	%	Pad Loopback	—
tIS	Data input setup time	1.75	—	—	ns	Pad Loopback	—
tIS	Data input setup time	9	—	—	ns	Internal Loopback	—
tIH	Data input hold time	1	—	—	ns	Pad Loopback	—
tIH	Data input hold time	1	—	—	ns	Internal Loopback	—
tOV	Data output valid time	—	—	1.75	ns	Pad Loopback	—
tOV	Data output valid time	—	—	1.75	ns	Internal Loopback	—
tIV	Data output invalid time	-1.5	—	—	ns	Pad Loopback	—
tIV	Data output invalid time	-1.5	—	—	ns	Internal Loopback	—
tCSSCK	CS to SCK time	5	—	—	ns	Pad Loopback	—
tCSSCK	CS to SCK time	5	—	—	ns	Internal Loopback	—
tSCKCS	SCK to CS time	3	—	—	ns	Pad Loopback	—
tSCKCS	SCK to CS time	3	—	—	ns	Internal Loopback	—

1. This frequency specification is valid only if output valid time of external flash is $\leq 5.5\text{ns}$, and if output valid time of external flash is more than 5.5ns but $\leq 6.5\text{ns}$, then maximum fSCK is 104MHz.
2. For S32K342 100MQFP, tSDC spec would be 44%-56% when ENET and SAI active along with QuadSPI at 120MHZ

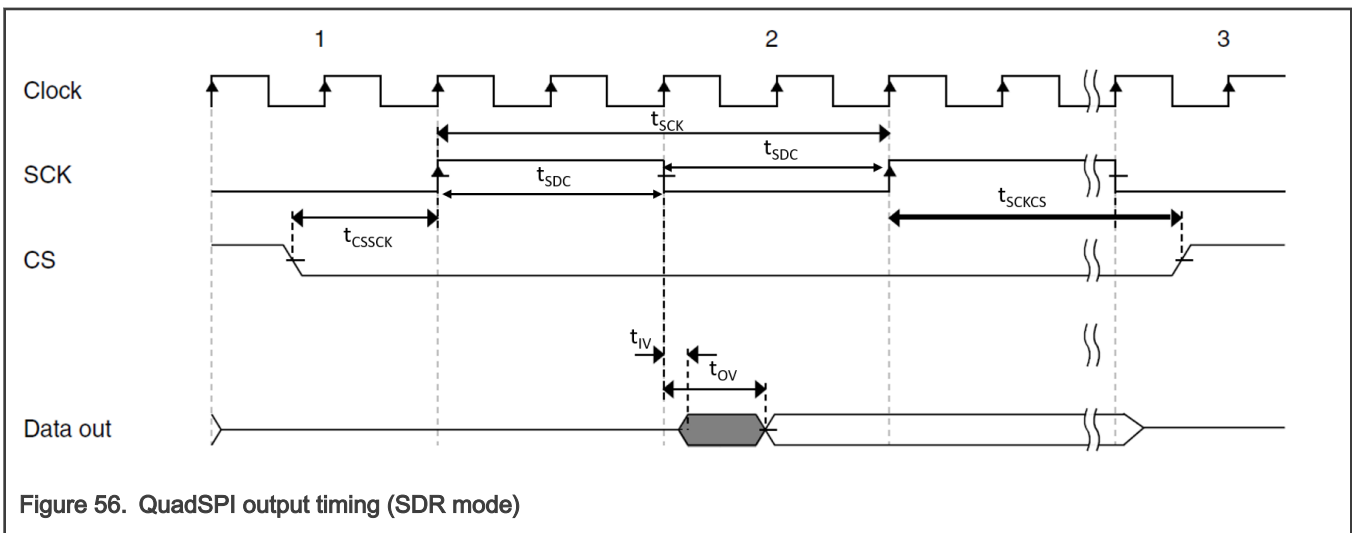
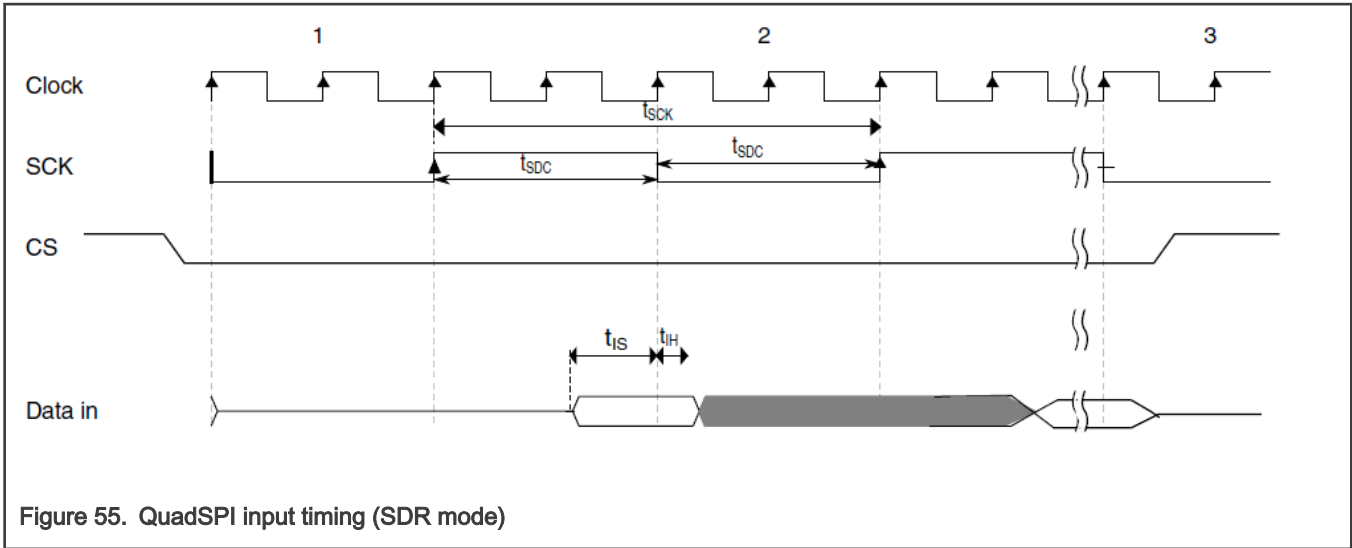

12.7.2 QuadSPI Octal 3.3V DDR 100MHz

The following table describes the QuadSPI electrical characteristics. Measurements are with maximum output load of 25pF, input transition of 1ns and pads configured with DSE = 1'b1 and SRE = 1'b0. I/O operating voltage ranges from 2.97V to 3.63V. QuadSPI trace length should be less than or equal to 2 inches. For Single and Dual IO modes of operation if external device doesn't have pull-up feature, then external pull-up must be added at board level for unused device pins. With external pull-up, performance of the interface may degrade in Quad IO mode based on load associated with external pull-up. QuadSPI support delay chain upto length 16, wherein delay length of low-frequency segment is 16 and length of high-frequency segment is 0. See the device Reference Manual for register and bit descriptions.

Set FLSHCR[TCSS]=2 and FLSHCR[TCSH]=5.

Table 51. QuadSPI Octal 3.3V DDR 100MHz

Symbol	Description	Min	Typ	Max	Unit	Condition	Spec Number
fSCK_DQS	SCK / DQS frequency ¹	—	—	100	MHz	—	—

Table continues on the next page...

Table 51. QuadSPI Octal 3.3V DDR 100MHz (continued)

Symbol	Description	Min	Typ	Max	Unit	Condition	Spec Number
tSDC	SCK duty cycle	45	—	55	%	—	—
tCL_SCK_DQS	SCK / DQS low time ¹	4.500	—	—	ns	—	—
tCH_SCK_DQS	SCK / DQS high time ¹	4.500	—	—	ns	—	—
tOD_DATA	Data output delay (w.r.t. SCK)	1.016	—	3.484	ns	—	—
tOD_CS	CS output delay (w.r.t. SCK) ²	3.016 - n/ fSCK	—	-0.016 + m/fSCK	ns	—	—
tDVW	Input data valid window ¹	3.284	—	—	ns	—	—
tISU_DQS	Input setup time (w.r.t. DQS) ¹	-0.816	—	—	ns	—	—
tIH_DQS	Input hold time (w.r.t. DQS) ¹	3.684	—	—	ns	—	—

1. Input timing assumes maximum input signal transition of 1 ns (20%/80%). DQS denotes external strobe provided by the Flash.
2. Where m=TCSS and n=TCSH-1.

12.7.3 QuadSPI Octal 3.3V DDR 120MHz

The following table describes the QuadSPI electrical characteristics. Measurements are with maximum output load of 25pF, input transition of 1ns and pads configured with DSE = 1'b1 and SRE = 1'b0. I/O operating voltage ranges from 2.97V to 3.63V. QuadSPI trace length should be less than or equal to 2 inches. For Single and Dual IO modes of operation if external device doesn't have pull-up feature, then external pull-up must be added at board level for unused device pins. With external pull-up, performance of the interface may degrade in Quad IO mode based on load associated with external pull-up. QuadSPI support delay chain upto length 16, wherein delay length of low-frequency segment is 16 and length of high-frequency segment is 0. See the device Reference Manual for register and bit descriptions.

Set FLSHCR[TCSS]=2 and FLSHCR[TCSH]=5.

Table 52. QuadSPI Octal 3.3V DDR 120MHz

Symbol	Description	Min	Typ	Max	Unit	Condition	Spec Number
fSCK_DQS	SCK / DQS frequency ¹	—	—	120	MHz	DLL and Auto-Learning mode enabled	—
fSCK_DQS	SCK / DQS frequency ¹	—	—	120	MHz	DLL mode enabled	—
tSCK	SCK clock period	1/ fSCK_D QS	—	—	ns	External DQS	—
tSDC	SCK / DQS duty cycle	45	—	55	%	External DQS	—

Table continues on the next page...

Table 52. QuadSPI Octal 3.3V DDR 120MHz (continued)

Symbol	Description	Min	Typ	Max	Unit	Condition	Spec Number
tCL_SCK_DQS	SCK / DQS low time ¹	3.75	—	—	ns	—	—
tCH_SCK_DQS	SCK / DQS high time ¹	3.75	—	—	ns	—	—
tOD_DATA	Data output delay (w.r.t. SCK)	0.816	—	2.934	ns	—	—
tOD_CS	CS output delay (w.r.t. SCK)	3.016	—	-0.766	ns	—	—
tDVW	Input data valid window ¹	2.518	—	—	ns	—	—
tISU_DQS	Input setup time (w.r.t. DQS) ¹	-0.616	—	—	ns	—	—
tIH_DQS	Input hold time (w.r.t. DQS) ¹	3.134	—	—	ns	—	—

1. Input timing assumes an input signal transition of 1 ns (20%/80%). DQS denotes external strobe provided by the Flash.

12.8 uSDHC

12.8.1 uSDHC SDR electrical specifications

The following table describes the uSDHC electrical characteristics. Measurements are with maximum output load of 25pF, input transition of 1ns and pad configured with DSE = 1'b1 and SRE = 1'b0. I/O operating voltage ranges from 2.97 V to 3.63 V.

Table 53. uSDHC SDR electrical specifications

Symbol	Description	Min	Typ	Max	Unit	Condition	Spec Number
fpp	Clock frequency (low speed) ^{1,2}	—	—	400	kHz	—	SD1
fpp	Clock frequency ^{2,3}	—	—	50	MHz	Medium pad	SD1
fpp	Clock frequency ^{2,4}	—	—	25	MHz	Standard pad	SD1
fOD	Clock frequency (identification mode) ²	100	—	400	kHz	—	SD1
tWL	Clock low time	6	—	—	ns	Medium pad	SD2
tWL	Clock low time	12	—	—	ns	Standard pad	SD2
tWH	Clock high time	6	—	—	ns	Medium pad	SD3
tWH	Clock high time	12	—	—	ns	Standard pad	SD3
tTLH	Clock rise time ^{2,5}	—	—	4	ns	Medium pad	SD4

Table continues on the next page...

Table 53. uSDHC SDR electrical specifications (continued)

Symbol	Description	Min	Typ	Max	Unit	Condition	Spec Number
tTLH	Clock rise time ^{2, 5}	—	—	8	ns	Standard pad	SD4
tTHL	Clock fall time ^{2, 5}	—	—	4	ns	Medium pad	SD5
tTHL	Clock fall time ^{2, 5}	—	—	8	ns	Standard pad	SD5
tOD	SDHC output delay (output valid) ²	-5.6	—	2.6	ns	SDHC_CLK to SDHC_CMD / SDHC_DAT	SD6
tISU	SDHC Input setup time ⁶	4.8	—	—	ns	SDHC_CMD / SDHC_DAT to SDHC_CLK	SD7
tIH	SDHC Input hold time ⁶	1.5	—	—	ns	SDHC_CLK to SDHC_CMD / SDHC_DAT	SD8

1. In low speed mode, card clock must be lower than 400 kHz, voltage ranges from 2.7V to 3.6V.
2. Output timing valid for maximum external load CL = 25pF, which is assumed to be a 10pF load at the end of a 50Ohm, un-terminated, 3.5 inch microstrip trace on standard FR4 (1.5pF/inch), (25pF total with margin).
3. In normal (full) speed mode for SD/SDIO card, clock frequency can be any value between 0–25 MHz. In high-speed mode, clock frequency can be any value between 0–50 MHz.
4. In normal (full) speed mode for MMC card, clock frequency can be any value between 0–25 MHz. In high-speed mode, clock frequency can be any value between 0–50 MHz.
5. The SDHC_CLK rise/fall time specification applies to the input clock transition required in order to meet the output delay specifications. SDHC_CLK output transition time is dependent on output load and GPIO pad drive strength. See the GPIO pad specifications for detail.
6. Input timing assumes an input signal slew rate of 3ns (20%/80%).

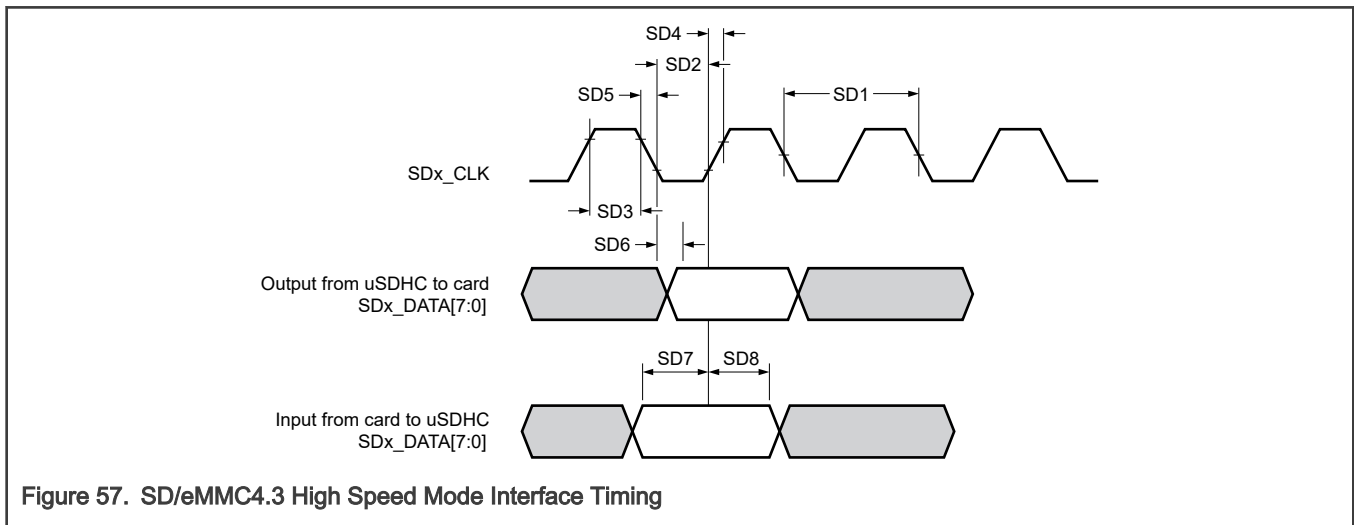

12.8.2 uSDHC DDR electrical specifications

The following table describes the uSDHC electrical characteristics. Measurements are with maximum output load of 25pF, input transition of 1ns and pad configured with DSE = 1'b1 and SRE = 1'b0. I/O operating voltage ranges from 2.97 V to 3.63 V.

Table 54. uSDHC DDR electrical specifications

Symbol	Description	Min	Typ	Max	Unit	Condition	Spec Number
fpp	Clock frequency (eMMC4.4/4.41 DDR) ¹	—	—	50	MHz	Medium pad	SD1
fpp	Clock frequency (eMMC4.4/4.41 DDR) ¹	—	—	25	MHz	Standard pad	SD1
fpp	Clock frequency (SD3.0 DDR) ¹	—	—	50	MHz	Medium pad	SD1
fpp	Clock frequency (SD3.0 DDR) ¹	—	—	25	MHz	Standard pad	SD1
tWL	Clock low time	6	—	—	ns	Medium pad	—
tWL	Clock low time	12	—	—	ns	Standard pad	—
tWH	Clock high time	6	—	—	ns	Medium pad	—
tWH	Clock high time	12	—	—	ns	Standard pad	—
tTLH	Clock rise time ^{1,2}	—	—	4	ns	Medium pad	—
tTLH	Clock rise time ^{1,2}	—	—	8	ns	Standard pad	—
tTHL	Clock fall time ^{1,2}	—	—	4	ns	Medium pad	—
tTHL	Clock fall time ^{1,2}	—	—	8	ns	Standard pad	—
tOD	SDHC output delay (output valid) ¹	2.7	—	5.6	ns	SDHC_CLK to SDHC_DAT	SD2
tOD	SDHC output delay (output valid) ¹	-5.6	—	2.6	ns	SDHC_CLK to SDHC_CMD	SD6 (See SDR figure)
tISU	SDHC Input setup time ³	1.6	—	—	ns	SDHC_DAT to SDHC_CLK	SD3
tISU	SDHC Input setup time ³	4.8	—	—	ns	SDHC_CMD to SDHC_CLK	SD7 (See SDR figure)
tIH	SDHC Input hold time ³	1.5	—	—	ns	SDHC_CLK to SDHC_DAT	SD4
tIH	SDHC Input hold time ³	1.5	—	—	ns	SDHC_CLK to SDHC_CMD	SD8 (See SDR figure)

- Output timing valid for maximum external load CL = 25pF, which is assumed to be a 10pF load at the end of a 50Ohm, un-terminated, 3.5 inch microstrip trace on standard FR4 (1.5pF/inch), (25pF total with margin).
- The SDHC_CLK rise/fall time specification applies to the input clock transition required in order to meet the output delay specifications. SDHC_CLK output transition time is dependent on output load and GPIO pad drive strength. See the GPIO pad specifications for detail.

3. Input timing assumes an input signal slew rate of 3ns (20%/80%).

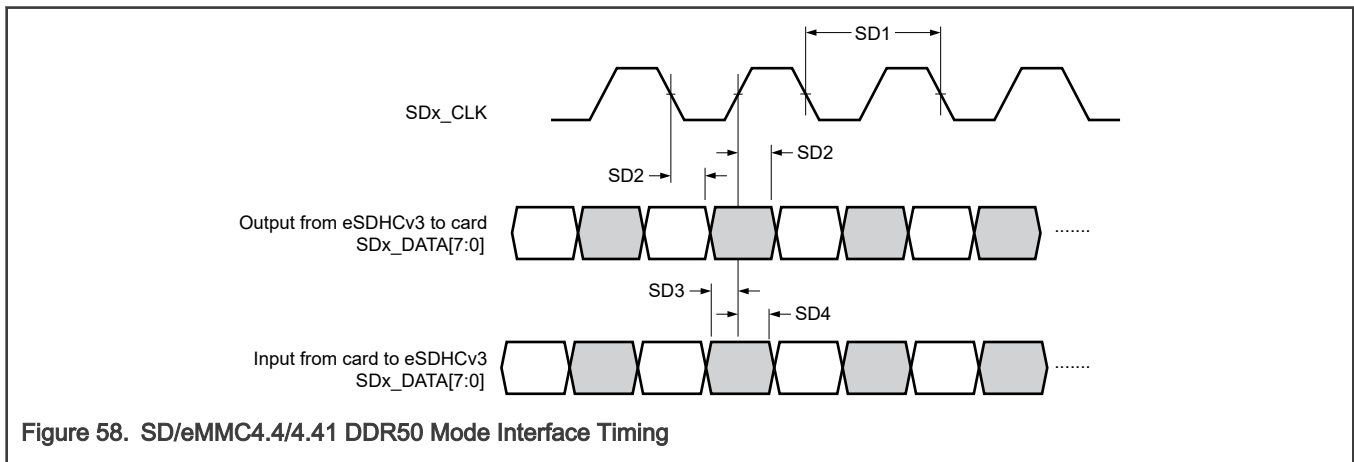

12.9 LPUART specifications

See [I/O parameters](#) for LPUART specifications.

13 Debug modules

13.1 Debug trace timing specifications

The following table describes the Debug trace electrical characteristics. Measurements are with maximum output load of 25pF, input transition of 1ns and pad configured with DSE = 1'b1 and SRE = 1'b0.

Table 55. Debug trace timing specifications

Symbol	Description	Min	Typ	Max	Unit	Condition	Spec Number
fTRACE	Trace clock frequency (trace on Fast pads)	—	—	120	MHz	—	—
fTRACE	Trace clock frequency (trace on StandardPlus pads)	—	—	25	MHz	—	—
tDVW	Data output valid window	1.2	—	—	ns	—	—
tDIV	Data output invalid	0.3	—	—	ns	—	—

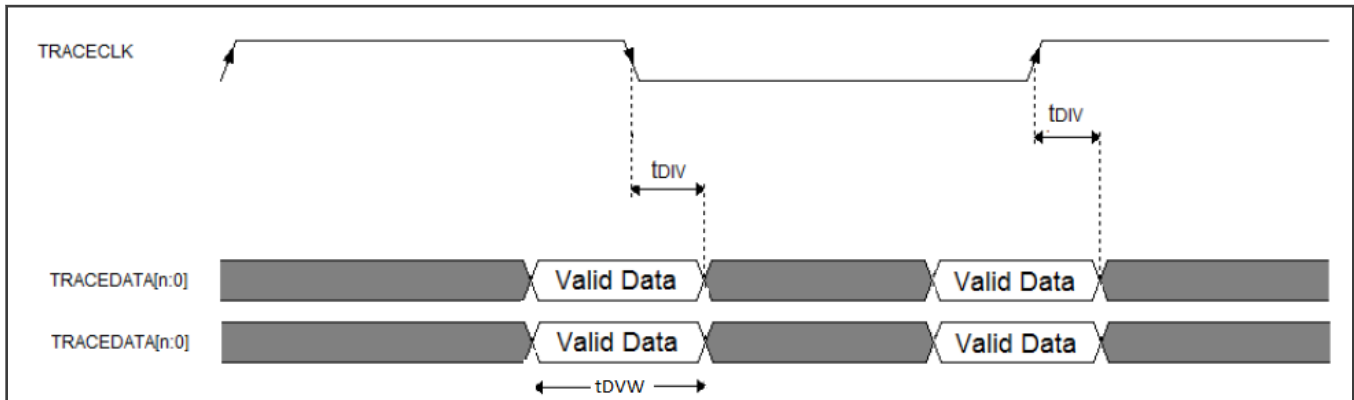

Figure 59. Trace CLKOUT specifications

13.2 SWD electrical specifications

The following table describes the SWD electrical characteristics. Measurements are with maximum output load of 30pF, input transition of 1ns and pad configured with DSE = 1'b1 and SRE = 1'b0.

Table 56. SWD electrical specifications

Symbol	Description	Min	Typ	Max	Unit	Condition	Spec Number
S1	SWD_CLK frequency	—	—	33	MHz	—	S1
S2	SWD_CLK cycle period	1 / S1	—	—	ns	—	S2
S3	SWD_CLK pulse width	40	—	60	%	—	S3
S4	SWD_CLK rise and fall times	—	—	1	ns	—	S4
S9	SWD_DIO input data setup time to SWD_CLK rise	5	—	—	ns	—	S9
S10	SWD_DIO input data hold time after SWD_CLK rising edge	5	—	—	ns	—	S10
S11	SWD_CLK high to SWD_DIO output data valid	—	—	22	ns	—	S11
S12	SWD_CLK high to SWD_DIO output data hi-Z	—	—	22	ns	—	S12
S13	SWD_CLK high to SWD_DIO output data invalid	0	—	—	ns	—	S13

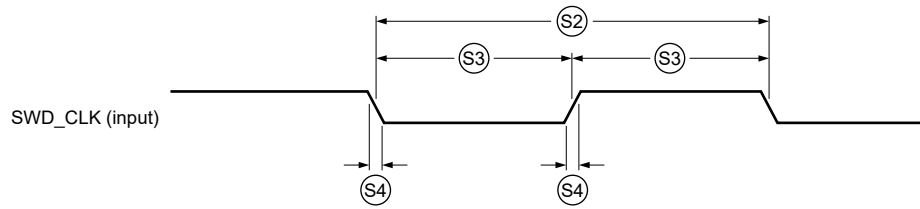

Figure 60. SWD Input Clock Timing

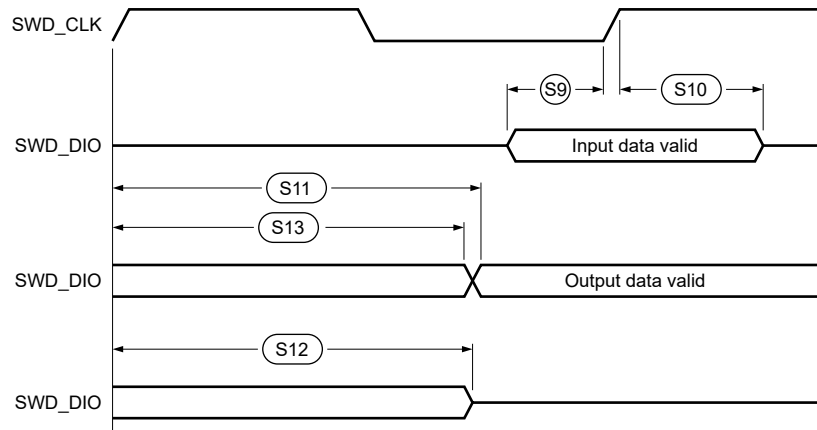

Figure 61. SWD Output Data Timing

13.3 JTAG electrical specifications

The following table describes the JTAG electrical characteristics. These specifications apply to JTAG and boundary scan. Measurements are with maximum output load of 30pF, input transition of 1ns and pad configured with DSE = 1'b1 and SRE = 1'b0.

Table 57. JTAG electrical specifications

Symbol	Description	Min	Typ	Max	Unit	Condition	Spec Number
tJCYC	TCK cycle time ^{1,2}	30	—	—	ns	—	1
tJDC	TCK clock pulse width	40	—	60	%	—	2
tTCKRISE	TCK rise/fall times (40%-70%)	—	—	1	ns	—	3
tTMSS, tTDIS	TMS, TDI data setup time	5	—	—	ns	—	4
tTMSH, tTDIH	TMS, TDI data hold time	5	—	—	ns	—	5
tTDOV	TCK low to TDO data valid ³	—	—	22	ns	—	6
tTDOI	TCK low to TDO data invalid	0	—	—	ns	—	7

Table continues on the next page...

Table 57. JTAG electrical specifications (continued)

Symbol	Description	Min	Typ	Max	Unit	Condition	Spec Number
tTDOHZ	TCK low to TDO high impedance	—	—	22	ns	—	8
tBSDV	TCK falling edge to output valid ⁴	—	—	600	ns	—	11
tBSDVZ	TCK falling edge to output valid out of high impedance	—	—	600	ns	—	12
tBSDHZ	TCK falling edge to output high impedance	—	—	600	ns	—	13
tBSDST	Boundary scan input valid to TCK rising edge	15	—	—	ns	—	14
tBSDHT	TCK rising edge to boundary scan input invalid	15	—	—	ns	—	15

1. Cycle time is 30ns assuming full cycle timing. Cycle time is 60ns assuming half cycle timing.
2. This timing applies to TDI, TDO, TMS pins, however, actual frequency is limited by pad type for EXTEST instructions. Refer to pad specification for allowed transition frequency
3. Timing includes TCK pad delay, clock tree delay, logic delay and TDO output pad delay.
4. Applies to all pins, limited by pad slew rate. Refer to IO delay and transition specification and add 20 ns for JTAG delay.

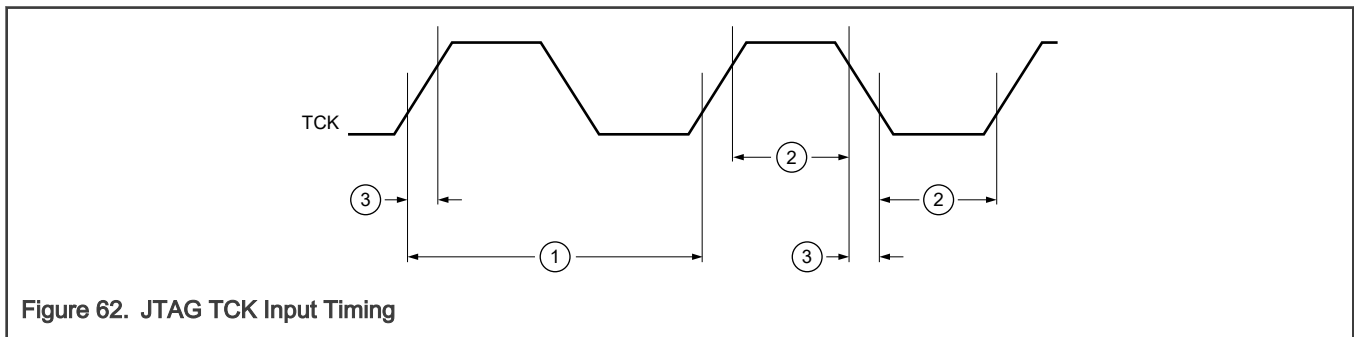

Figure 62. JTAG TCK Input Timing

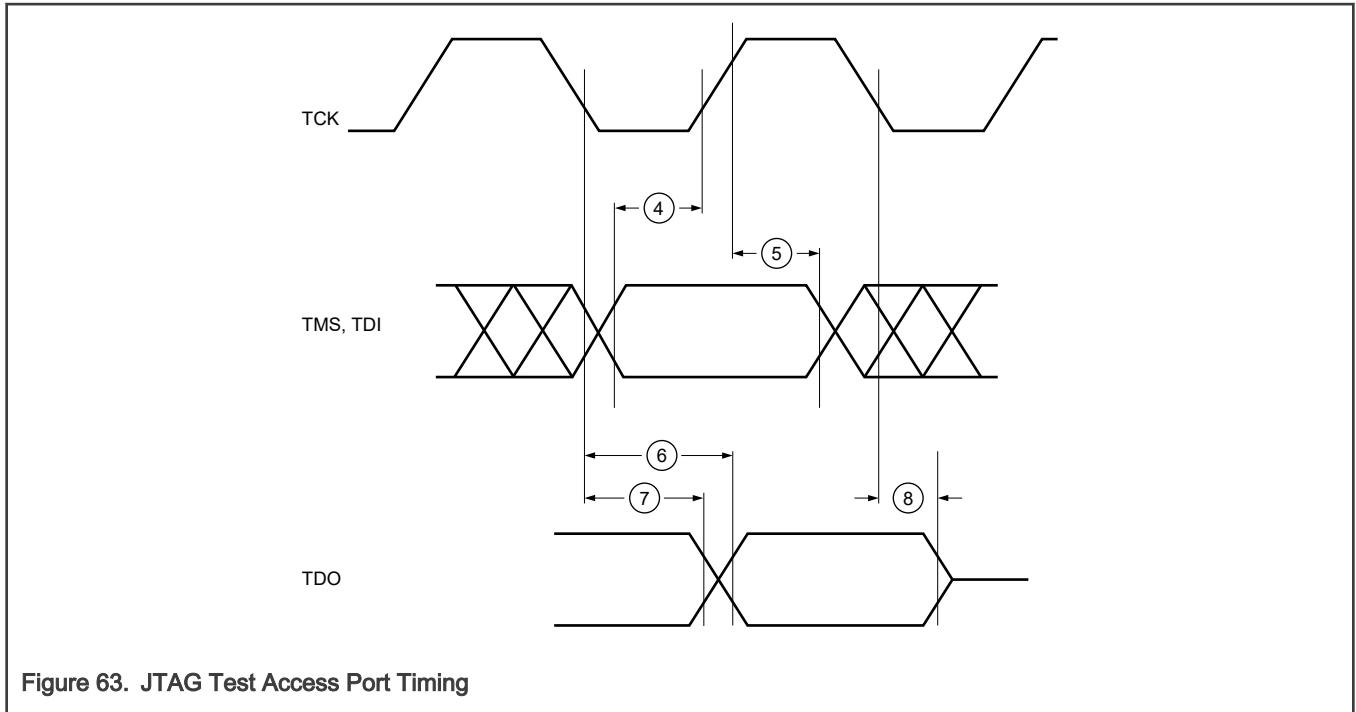

Figure 63. JTAG Test Access Port Timing

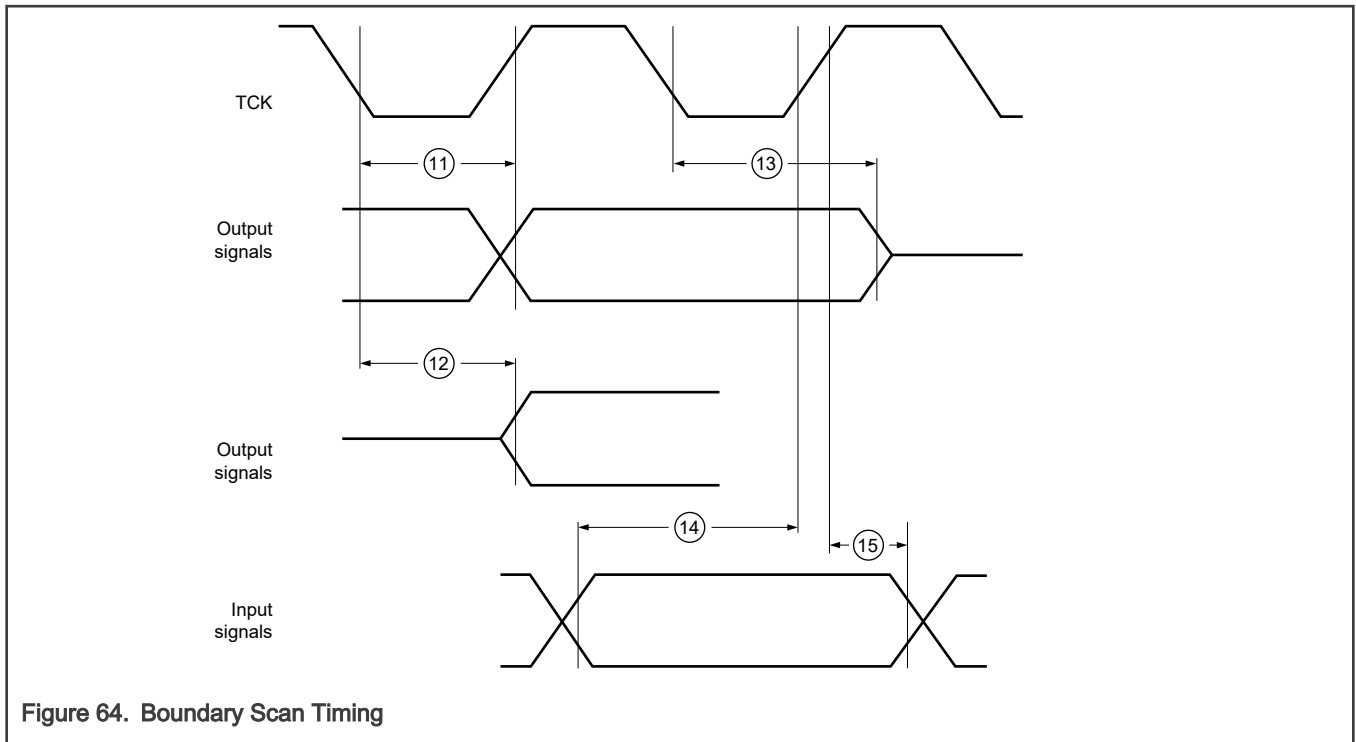

Figure 64. Boundary Scan Timing

14 Thermal Attributes

14.1 Description

The tables in the following sections describe the thermal characteristics of the device.

NOTE

Junction temperature is a function of die size, on-chip power dissipation, package thermal resistance, mounting side (board) temperature, ambient temperature, air flow, power dissipation or other components on the board, and board thermal resistance.

14.2 Thermal characteristics

Thermal characteristics for the LQFP, MaxQFP & MAPBGA package in the S32K3 family.

Table 58. Thermal characteristics

Rating	Conditions	Symbol	Package	Device					Unit
				S32K311	S32K312	S32K342 S32K341 S32K322	S32K344 S32K314 S32K324	S32K358 S32K348 S32K328 S32K338	
Thermal resistance, Junction to Ambient (Natural Convection)	Four-layer board (2s2p)	$R_{\theta JA}$	48-LQFP	TBD	NA	NA	NA	NA	°C/W
			100-MaxQFP	TBD	38	33.8	NA	NA	°C/W
			172-MaxQFP	NA	30.5	29.6	28.9	NA	°C/W
			257-MAPBGA	NA	NA	NA	26.8	NA	°C/W
			172 MAXQFP_EP	NA	NA	NA	NA	15.6	°C/W
			289-MAPBGA	NA	NA	NA	NA	19.6	°C/W
Thermal resistance, Junction to Package Top	Natural Convection	$R_{\theta JT}$	48-LQFP	TBD	NA	NA	NA	NA	°C/W
			100-MaxQFP	TBD	0.8	0.5	NA	NA	°C/W
			172-MaxQFP	NA	0.5	0.5	0.4	NA	°C/W
			257-MAPBGA	NA	NA	NA	0.3	NA	°C/W
			172 MAXQFP_EP	NA	NA	NA	NA	TBD	°C/W
			289-MAPBGA	NA	NA	NA	NA	TBD	°C/W

15 Dimensions

15.1 Obtaining package dimensions

Package dimensions are provided in the package drawings. To find a package drawing, go to nxp.com and perform a keyword search for the drawing's document number:

Package option	Document Number
257-ball MAPBGA	98ASA01483D
172-pin MaxQFP	98ASA01107D
100-pin MaxQFP	98ASA01570D
172-pin MAXQFP_EP	98ASA01667D
289-ball MAPBGA	98ASA01216D

16 Revision history

The following table lists the changes in this document.

Rev 4, April 2022
<ul style="list-style-type: none"> • Removed S32K312 from preliminary list from the title of the document and "Overview". • In features on first page added MAPBGA289 to the package list and updated GPIO pins upto 235. • Removed "NDA required" term from all block diagrams. • In "Ordering information", added MaxQFP-EP package suffix. • In section "Absolute maximum ratings", and "Voltage and current operating requirements", added S32K341 variant to the sentence "The VDD_HV_B and V15 voltage supply domains are only present....". • In section "Voltage and current operation requirement", the footnote attached to supply ramp rate is updated as " The MCU Supply ramp applicable to the MCU input/external supplies...". • Updated capacitor symbol to non-polarity in following figures at V25 and V11: <ul style="list-style-type: none"> — Power management system - S32K344, S32K324, S32K341, S32K314, S32K342, and S32K322. — Power management system - S32K312, S32K311 • In "Power management system - S32K358" figure, updated connections to optional circuit with dashed lines for PGATE_CTRL and VSS_DCDC. • In section "SMPS regulator electrical specifications", added a sentence "The chip hardware design guidelines documents lists the recommended part numbers of PMOS & Schottky diode." • In table "SMPS regulator electrical specifications" : <ul style="list-style-type: none"> — The typ. value of "External coil inductance" changed from 5 to 4.7uH. — Added "Schottky diode reverse voltage" with Min value 5.0 V. — Added "Schottky diode forward current" with Min value 1.0 A. • In section "SMPS regulator electrical specifications" changed "COUT_V15" to "COUT_V15_SMPS" to match it with corresponding figure. • In section "Recommended Decoupling Capacitors" changed "COUT_V15" to "COUT_V15_NPN" to match it with corresponding figure. • In section "Recommended Decoupling Capacitors", following footnotes updated:

Rev 4, April 2022

- Footnote attached to CDEC "Optionally, 1 nF capacitors can be added...".
- Footnote attached to CBULK "For devices where the VDD_HV_B domain is present, if the VDD_HV_B...".
- Added footnote to CBULK "These capacitors must be placed close to the source."
- In section "Recommended Decoupling Capacitors", updated and added decoupling capacitors diagrams.
- In section "NPN Ballast Transistor Control Specification" added specification for VDD_HV_NPN.
- Updated "Ballast circuit" figure under section " NPN Ballast Transistor Control Specification".
- Current IDD specs are updated for S32K12 for following :
 - Table "STANDBY mode supply currents"
 - Table "Low speed RUN mode supply currents"
 - Table "RUN mode supply currents (peripherals disabled)"
 - Table "Example RUN mode configuration supply current"
- In section "supply current", Removed table "Recommended current limits in board design" and related sentence "The power supplies for the voltage"
- In section "Power management", added section "Cyclic wake-up current" and removed table "Low-power, cyclic operation mode" from supply currents.
- In section "GPIO DC electrical specifications, 3.3V Range (2.97V - 3.63V)", with symbol "ILKG_33_S", the condition has been changed from PTC0 to PTD0.
- In section "5.0V (4.5V - 5.5V) GPIO Output AC Specification":
 - for Symbol "TR_TF_50_F" with condition "DSE=0, SRE=1, Capacitance=50pF" Min changed from "2.8" to "1.9".
 - for Symbol "TR_TF_50_F" with condition "DSE=0, SRE=1, Capacitance=50pF" Max changed from "10.2" to "7.7".
 - for Symbol "TR_TF_50_F" with condition "DSE=1, SRE=1, Capacitance=50pF" Min changed from "1.9" to "1.3".
 - for Symbol "TR_TF_50_F" with condition "DSE=1, SRE=1, Capacitance=50pF" Max changed from "6.7" to "5.1".
 - for Symbol "TR_TF_50_F" with condition "DSE=0, SRE=0, Capacitance=50pF" Min changed from "2.0" to "1.0".
 - for Symbol "TR_TF_50_F" with condition "DSE=0, SRE=0, Capacitance=50pF" Max changed from "7.4" to "5.3".
 - for Symbol "TR_TF_50_F" with condition "DSE=1, SRE=0, Capacitance=25pF" Min changed from "0.9" to "0.3".
 - for Symbol "TR_TF_50_F" with condition "DSE=1, SRE=0, Capacitance=25pF" Max changed from "3.0" to "0.9".
 - for Symbol "TR_TF_50_F" with condition "DSE=1, SRE=1, Capacitance=25pF" Min changed from "1.3" to "0.9".
 - for Symbol "TR_TF_50_F" with condition "DSE=1, SRE=1, Capacitance=25pF" Max changed from "5.1" to "4.1".
 - for Symbol "TR_TF_50_F" with condition "DSE=1, SRE=0, Capacitance=50pF" Min changed from "1.6" to "0.9".
 - for Symbol "TR_TF_50_F" with condition "DSE=1, SRE=0, Capacitance=50pF" Max changed from "3.6" to "3.0".
 - for Symbol "TR_TF_50_F" with condition "DSE=0, SRE=0, Capacitance=25pF" Min changed from "1.0" to "0.4".
 - for Symbol "TR_TF_50_F" with condition "DSE=0, SRE=0, Capacitance=25pF" Max changed from "5.3" to "3.1".
 - for Symbol "TR_TF_50_F" with condition "DSE=0, SRE=1, Capacitance=25pF" Min changed from "1.9" to "1.5".
 - for Symbol "TR_TF_50_F" with condition "DSE=0, SRE=1, Capacitance=25pF" Max changed from "7.7" to "6.1".
- In section "SAR ADC", the footnote attached to "ADC Total Unadjusted Error" is updated as "TUE spec for precision and standard channels is based on 12-bit level resolution".

Rev 4, April 2022

- In section "Supply Diagnosis", for Symbol "AN_ACC" and "AN_T_on" footnote added "These specs will have degraded performan..."
- In section "Fast External Oscillator (FXOSC)", for Symbol "TFXOSC" description changed from "Fxosc start up time" to "Fxosc start up time (ALC enabled)".
- In section "Fast External Oscillator (FXOSC)", removed the crystal part numbers and related information which includes following sentences, "In crystal mode NX5032GA crystal", " In crystal mode NX8045GB crystal ... " and updated sentence "To ensure stable oscillations, FXOSC incorporates the feedback resistance internally."
- In section "LPSPI", updated the sentence updated maximum output load of 50pF to 30pF.
- In section "LPSPI", footnote attached to "fperiph" is updated to mention clock name instead of frequency. "For LPSPI0 instance, max. peripheral..."
- In section "I3C Push-Pull Timing Parameters for SDR Mode", Symbol "tv" and tHI are deleted.
- Added section "Ethernet RGMII".
- In all QuadSPI modes updated trace length from 3 inches to 2 inches.
- Added "QuadSPI Octal 3.3V DDR 100MHz" mode.
- Deleted "QuadSPI Quad 3.3V DDR 80MHz" mode.
- In section "QuadSPI Octal 3.3V DDR 120MHz" :
 - For symbol "tOD_DATA", Max. value changed from "2.567" to " 2.934".
 - For symbol "tOD_CS", Min value has been changed from "3.015" to "3.016" and Max. value changed from "-1.33" to "-0.766".
 - For symbol "tDVW", Min value has been changed from "2.314" to "2.518".
 - For symbol "tIH_DQS", Min value has been changed from "2.767" to "3.134".
- uSDHC specifications are updated thoroughly.
- In "Thermal characteristics":
 - Updated table header to include all variants.
 - For S32K312 100-MaxQFP updated $R_{\theta JA}$ from 34.8 to 38 °C/W and $R_{\theta JT}$ from 0.6 to 0.8 °C/W.
 - For S32K3x4, 257MAPBGA updated $R_{\theta JA}$ from 27 to 26.8 °C/W.
- Updated Legal information.

Rev 3, Oct 2021

- Datasheet classification is updated to "Technical data" for S32K344.
- In section "Supply currents" added values for 85C (typ and max) and updated 105 (max) and 125 (max) values for S32K344.
- In front page features, added MaxQFP172 with Exposed pad (EP) option and information on I3C.
- In section "Overview", added a note "S32K3x1, S32K3x2 and S32K3x8 specific information".
- In "Feature comparision" section added footnote to add information about MaxQFP172 with Exposed pad (EP) package for S32K3x8 devices.
- VDD_HV_SMPS is changed to VDD_DCDC throughout.

Rev 3, Oct 2021

- In section "Absolute maximum ratings", footnote attached to "I_INJSUM_DC_ABS" is extended to add information "See application note AN4731 for...".
- Figure "Power management system - S32K344, S32K324, S32K341, S32K314, S32K342, and S32K322." is updated to add COUT_V15 capacitor.
- Figure "Power management system - S32K358" is updated to add COUT_V15 capacitor and optional circuit explained in the notes.
- In section "SMPS regulator electrical specifications", COUT_V15 is added to "External bypass capacitor".
- Figure "Package decoupling capacitor pinout diagram" is updated to show MaxQFP172-EP package.
- Table title "Current limit requirements for board design" is changed to "Recommended current limits in board design" and added a note as "The power supplies for the voltage rails must be...".
- In section "GPIO DC electrical specifications, 3.3V Range (2.97V - 3.63V)":
 - for ILKG_33_S updated condition to update pins which has Analog Function Count=2/3
 - for ILKG_33_M updated condition to update pins which has Analog Function Count=1
 - added ILKG_33_M with condition "PTE8 and PTD6"
 - updated ILKG_33, -120 nA (min) and 120 nA (max).
 - updated condition of IOH_*, IOL_* to add < and > symbols.
 - added IOHT specification.
 - Updated sentence "I/O current specifications are...". and removed "RMS current values are given....".
- In section "GPIO DC electrical specifications, 5.0V (4.5V - 5.5V)":
 - for ILKG_50_S updated condition to update pins which has Analog Function Count=2/3
 - for ILKG_50_M updated condition to update pins which has Analog Function Count=1
 - added ILKG_50_M with condition "PTE8 and PTD6"
 - updated ILKG_50, -150 nA (min) and 150 nA (max).
 - updated condition of IOH_*, IOL_* to add < and > symbols.
 - added IOHT specification.
 - Updated sentence "I/O current specifications are...". and removed "RMS current values are given....".
- In section "5.0V (4.5V - 5.5V) GPIO Output AC Specification":
 - for Symbol "TR_TF_50_S" with condition "Capacitance=25pF" Min changed from "TBD" to "5"
 - for Symbol "TR_TF_50_S" with condition "Capacitance=25pF" Max changed from "TBD" to "21"
 - for Symbol "TR_TF_50_S" with condition "Capacitance=50pF" Min changed from "TBD" to "10"
 - for Symbol "TR_TF_50_S" with condition "Capacitance=50pF" Max changed from "TBD" to "31"
 - for Symbol "TR_TF_50_SP" with condition "DSE=0, Capacitance=25pF" Min changed from "5" to "3.5"
 - for Symbol "TR_TF_50_SP" with condition "DSE=1, Capacitance=25pF" Min changed from "2.4" to "1.2"
 - for Symbol "TR_TF_50_SP" with condition "DSE=0, Capacitance=50pF" Min changed from "8.9" to "7.1"
 - for Symbol "TR_TF_50_SP" with condition "DSE=1, Capacitance=50pF" Min changed from "4.1" to "3.4"
 - for Symbol "TR_TF_50_M" with condition "DSE=0, SRE=0, Capacitance=25pF" Min changed from "2.5" to "1.8"

Rev 3, Oct 2021

- for Symbol "TR_TF_50_M" with condition "DSE=0, SRE=1, Capacitance=25pF" Min changed from "3" to "2.5"
- for Symbol "TR_TF_50_M" with condition "DSE=1, SRE=0, Capacitance=25pF" Min changed from "1" to "0.8"
- for Symbol "TR_TF_50_F" with condition "DSE=0, SRE=0, Capacitance=25pF" Max changed from "4.3" to "5.3"
- for Symbol "TR_TF_50_F" with condition "DSE=1, SRE=0, Capacitance=25pF" Max changed from "1.6" to "3.0"
- In section "3.3V (2.97V - 3.63V) GPIO Output AC Specification":
 - for Symbol "TR_TF_33_S" with condition "Capacitance=25pF" Min changed from "TBD" to "6.5"
 - for Symbol "TR_TF_33_S" with condition "Capacitance=25pF" Max changed from "TBD" to "28"
 - for Symbol "TR_TF_33_S" with condition "Capacitance=50pF" Min changed from "TBD" to "11"
 - for Symbol "TR_TF_33_S" with condition "Capacitance=50pF" Max changed from "TBD" to "43"
 - for Symbol "TR_TF_33_SP" with condition "DSE=0, Capacitance=25pF" Min changed from "5" to "4"
 - for Symbol "TR_TF_33_SP" with condition "DSE=1, Capacitance=25pF" Min changed from "2.4" to "2.0"
 - for Symbol "TR_TF_33_M" with condition "DSE=0, SRE=0, Capacitance=25pF" Min changed from "3.2" to "2.2"
 - for Symbol "TR_TF_33_M" with condition "DSE=0, SRE=1, Capacitance=25pF" Min changed from "3.8" to "3.0"
 - for Symbol "TR_TF_33_M" with condition "DSE=1, SRE=0, Capacitance=25pF" Min changed from "1" to "0.8"
 - for Symbol "TR_TF_33_F" with condition "DSE=0, SRE=0, Capacitance=25pF" Min changed from "1.1" to "0.5"
 - for Symbol "TR_TF_33_F" with condition "DSE=0, SRE=0, Capacitance=25pF" Max changed from "7.0" to "4"
 - for Symbol "TR_TF_33_F" with condition "DSE=0, SRE=1, Capacitance=25pF" Min changed from "2.6" to "2.1"
 - for Symbol "TR_TF_33_F" with condition "DSE=0, SRE=1, Capacitance=25pF" Max changed from "11.0" to "9"
 - for Symbol "TR_TF_33_F" with condition "DSE=1, SRE=0, Capacitance=25pF" Min changed from "0.8" to "0.4"
 - for Symbol "TR_TF_33_F" with condition "DSE=1, SRE=0, Capacitance=25pF" Max changed from "3.4" to "2"
 - for Symbol "TR_TF_33_F" with condition "DSE=1, SRE=1, Capacitance=25pF" Min changed from "1.5" to "1.2"
 - for Symbol "TR_TF_33_F" with condition "DSE=1, SRE=1, Capacitance=25pF" Max changed from "7.8" to "6.4"
 - for Symbol "TR_TF_33_F" with condition "DSE=0, SRE=0, Capacitance=50pF" Min changed from "2.5" to "1.1"
 - for Symbol "TR_TF_33_F" with condition "DSE=0, SRE=0, Capacitance=50pF" Max changed from "10.8" to "7"
 - for Symbol "TR_TF_33_F" with condition "DSE=0, SRE=1, Capacitance=50pF" Min changed from "3.6" to "2.6"
 - for Symbol "TR_TF_33_F" with condition "DSE=0, SRE=1, Capacitance=50pF" Max changed from "15.0" to "11"
 - for Symbol "TR_TF_33_F" with condition "DSE=1, SRE=0, Capacitance=50pF" Min changed from "1.5" to "0.8"
 - for Symbol "TR_TF_33_F" with condition "DSE=1, SRE=0, Capacitance=50pF" Max changed from "5.5" to "4.2"
 - for Symbol "TR_TF_33_F" with condition "DSE=1, SRE=1, Capacitance=50pF" Min changed from "2.2" to "1.5"
 - for Symbol "TR_TF_33_F" with condition "DSE=1, SRE=1, Capacitance=50pF" Max changed from "10.0" to "7.8"
- In section "SAR ADC", added paragraph "All below specs are applicable when only one ADC instance is in operation to determine the most appropriate settings for AVGS." and removed footnote from RS specification.
- In section "SAR ADC", added specifications for CP1, CP2 and RSW1 corresponding to all channels, shared channels and precision channels. Also added the related figure.
- In section "PLL", removed some non-applicable footnotes.
- In section "LPSPI", added information before the table The Low Power Serial Peripheral Interface (LPSPI) provides a synchronous serial bus with master....".

Rev 3, Oct 2021

- In section "LPSPi0 20 MHz and 15 MHz Combinations", added note as "Trace length should not exceed 11 inches for SCK pad when used in Master loopback mode."
- Added "I3C" specifications.
- In section "Ethernet MII (100 Mbps)", for "RXCLK frequency" typ value moved to max.
- In section "Ethernet RMII", added paragraph "The following timing specs are defined at the device I/O pin and must beI/O operating voltage ranges from 2.97 V to 3.63 V."
- In section "QuadSPI Quad 3.3V SDR 120MHz", for Symbol "tSDC" footnote added "For S32K342 100MQFP, tSDC spec would be ..."
- In section "QuadSPI Quad 3.3V SDR 120MHz" added sentence "Program register value QuadSPI_DLLCRA[SLV_FINE_OFFSET] to 4'b0001."
- In section "QuadSPI Octal 3.3V DDR 120MHz", Symbol "tSCK" min is clarified, condition updated to External DQS and "tSCK" with condition Internal Loopback is deleted.
- In section "QuadSPI Octal 3.3V DDR 120MHz", Symbol "tSDC" condition updated to External DQS and "tSDC" with condition Internal Loopback is deleted..
- In section "QuadSPI Octal 3.3V DDR 120MHz", specifications tISU_PCS, tIH_PCS, tCK2CKmin and tCK2CKmax are deleted.

Rev 2, Aug 2021

- Added section "Overview".
- In block diagrams:
 - S32K311/S32K312/S32K314 removed "Scalable ARM M7 core in Lock step" and added "Single ARM M7 core".
 - S32K322/S32K324 removed "Scalable ARM M7 core in Lock step" and added "Two independent ARM M7 cores".
- In "Absolute maximum ratings" and "Voltage and current operating requirements":
 - Some general footnotes are moved to top of table
 - VDD_HV_SMPS added footnotes
- In "Voltage and current operating requirements" for VREFH extended footnote "VREFH should always be equal to...".
- Updated title - Power management system - S32K344, S32K324, S32K341, S32K314, S32K342, and S32K322.
- In figure "Power management system - S32K358" updated double bond to triple bond.
- In section "Recommended Decoupling Capacitors" added COUT_V11 with typ as 1 uF.
- Added section "Power mode transition operating behaviors" and its subsections:
 - Power mode transition operating behaviour
 - Boot time, HSE firmware not installed
 - Boot time, HSE firmware installed
 - HSE firmware memory verification time examples
- Moved information from "Supply monitoring" to "Supply diagnosos" and attached it to "AN_ACC". The information is "If V15 > VDD_HV_A +100mV then..."
- Updated figure "Package decoupling capacitor pinout diagram" to add 289 MapBGA

Rev 2, Aug 2021

- In section "Glitch Filter", added sentence "... WKPU pins and TRGMUX inputs 60-63."
- Section "Flash memory program and erase specifications" updated thoroughly.
- In section "Flash memory module life specifications" removed footnotes 1 and 2.
- In section "Data retention vs program/erase cycles" added sentence before related to figure "The spec window represents qualified limits."
- In section "Flash memory AC timing specifications":
 - Updated register naming representation
 - Added footnote to t_{drcv} min as " In extreme cases (1 block configurations)..."
 - Max updated to "50 system clock periods" for t_{aistop}
- In section "Flash memory read timing parameters" mentioned part numbers for each table as applicable.
- In section "SAR ADC", for Symbol "fAD_CK" added new spec and max updated to 120.
- In section "FIRC", Symbol "IFIRC" is deleted.
- In section "SIRC", Symbol "lvdda" with condition "On state" is deleted.
- In section "PLL", clarification added in condition column for jitter specifications.
- In section "Fast External Oscillator (FXOSC)", for Symbol "FREQ_BYPASS", "TRF_BYPASS" and "CLKIN_DUTY_BYPASS" footnote added "For bypass mode applications, the EXTAL ...".
- In section "Fast External Oscillator (FXOSC)", for Symbol "TFXOSC" footnote added "The startup time specification is valid ...".
- In section "Fast External Oscillator (FXOSC)", Symbol "IFXOSC" specs are merged into one and description and condition updated.
- In section "Fast External Oscillator (FXOSC)", added paragraph "Drive level is a crystal specification and".
- In section "LPSPI", Symbol "tSPSCK" with condition "Slave_10Mbps" is added.
- In section "LPSPI", Symbol "tSPSCK" with condition "Master_10Mbps" is added.
- Updated title to mention LPSPI0 of "LPSPI0 20 MHz and 15 MHz Combinations", and updated header "20Mbps" to "20Mbps (In loopback mode only)".
- In "I3C" section, added two sentences.
- Updated "QuadSPI" sections.
- Editorial updates.

Rev 2 Draft B, Mar 2021

- Updated "block diagrams" and "Feature comparison"
- Updated "Ordering information" to add 289 package and removed one.
- In section "Absolute maximum ratings", Symbol "VDD_HV_SMPS" is added.
- In section "Absolute maximum ratings", for Symbol "I_INJPAD_DC_ABS" and "I_INJSUM_DC_ABS" footnote updated "When input pad voltage levels are close ...".
- In section "Voltage and current operating requirements", Symbol "IINJSUM_DC_OP" and "IINJPAD_DC_OP" condition is updated

Rev 2 Draft B, Mar 2021

- In section "Voltage and current operating requirements", Symbol "VDD_HV_SMPS" is added.
- In section "Voltage and current operating requirements", for Symbol "I_INJPAD_DC_ABS" and "I_INJSUM_DC_ABS" footnote updated "When input pad voltage levels are close ...".
- In section "Power management":
 - "Power management system - S32K344, S32K324, S32K314" figure updated.
 - "Power management system - S32K312, S32K311" figure updated.
 - "Power management system - S32K358" figure added.
- In section "Supply Monitoring", Symbol "HVD_V15" is added.
- In section "Supply Monitoring", for "LVD_VDD_HV_A", symbol and description updated.
- Added section "SMPS regulator electrical specifications"
- In section "NPN Ballast Transistor Control Specification", fig with title "Ballast circuit" is changed.
- In section "Supply currents" and "operating mode" tables are updated.
- In section "GPIO DC electrical specifications, 3.3V Range (2.97V - 3.63V)", fig with title "Reference Load Diagram" is changed.
- In section "GPIO DC electrical specifications, 3.3V Range (2.97V - 3.63V)", footnote updated "A positive value is leakage flowing into...".
- In section "GPIO DC electrical specifications, 5.0V (4.5V - 5.5V)", Symbol "ILKG_50_S_PTE13" with condition "PMC VRC_CTRL pin" is added.
- In section "GPIO DC electrical specifications, 5.0V (4.5V - 5.5V)", footnote updated "A positive value is leakage flowing into...".
- In section "GPIO DC electrical specifications, 5.0V (4.5V - 5.5V)", fig with title "Reference Load Diagram" is changed.
- In section "Flash memory specification", added specs for 512KB and 2MB specifications.
- In table "Flash memory AC timing specifications", taistop max updated.
- Updated "Flash Read Wait State Settings"
- In section "Low Power Comparator (LPCMP)", updated IDLSS typ to 17uA.
- In section "Low Power Comparator (LPCMP)", updated INL and DNL.
- In section "Low Power Comparator (LPCMP)", updated paragraph "For devices where the VDD_HV_B domain is present..."
- In "Low Power Comparator (LPCMP)" added hysteresis plots.
- In section "PLL", symbol "FPLL_out" description updated to add (PLL_PHIn_CLK)
- In section "PLL", "IPLL_V25" deleted.
- In section "PLL", updated jitter specifications.
- In section "FXOSC", updated paragraph "To improve the FXOSC jitter and duty cycle performance..."
- In section "SXOSC", updated description of "ISXOSC" to Oscillator Analog circuit supply current.
- In section "I2C", added paragraph "For supported baud rate"
- Added section "I3C".
- In section "FlexCAN characteristics", added paragraph "For supported baud rate"

Rev 2 Draft B, Mar 2021

- Added QuadSPI DDR electrical specifications for Octal and Quad.
- Added uSDHC specifications.
- Updated "Thermal characteristics" and "Obtaining package dimensions"

Rev 2 Draft A, Nov 2020

- Updated features to show maximum memory support up to 8 MB.
- Added information for S32K341.
- Updated "Block diagrams".
- Updated "Feature comparison"
- Updated "Thermal characteristics" to add data for S32K312 and S32K342.
- Added document number for 172-pin MaxQFP package in section "Obtaining package dimensions"

Legal information

Data sheet status

Document status ^{[1][2]}	Product status ^[3]	Definition
Objective [short] data sheet	Development	This document contains data from the objective specification for product development.
Preliminary [short] data sheet	Qualification	This document contains data from the preliminary specification.
Product [short] data sheet	Production	This document contains the product specification.

[1] Please consult the most recently issued document before initiating or completing a design.

[2] The term 'short data sheet' is explained in section "Definitions".

[3] The product status of device(s) described in this document may have changed since this document was published and may differ in case of multiple devices. The latest product status information is available on the Internet at URL <http://www.nxp.com>.

Definitions

Draft — A draft status on a document indicates that the content is still under internal review and subject to formal approval, which may result in modifications or additions. NXP Semiconductors does not give any representations or warranties as to the accuracy or completeness of information included in a draft version of a document and shall have no liability for the consequences of use of such information.

Short data sheet — A short data sheet is an extract from a full data sheet with the same product type number(s) and title. A short data sheet is intended for quick reference only and should not be relied upon to contain detailed and full information. For detailed and full information see the relevant full data sheet, which is available on request via the local NXP Semiconductors sales office. In case of any inconsistency or conflict with the short data sheet, the full data sheet shall prevail.

Product specification — The information and data provided in a Product data sheet shall define the specification of the product as agreed between NXP Semiconductors and its customer, unless NXP Semiconductors and customer have explicitly agreed otherwise in writing. In no event however, shall an agreement be valid in which the NXP Semiconductors product is deemed to offer functions and qualities beyond those described in the Product data sheet.

Disclaimers

Limited warranty and liability — Information in this document is believed to be accurate and reliable. However, NXP Semiconductors does not give any representations or warranties, expressed or implied, as to the accuracy or completeness of such information and shall have no liability for the consequences of use of such information. NXP Semiconductors takes no responsibility for the content in this document if provided by an information source outside of NXP Semiconductors.

In no event shall NXP Semiconductors be liable for any indirect, incidental, punitive, special or consequential damages (including - without limitation - lost profits, lost savings, business interruption, costs related to the removal or replacement of any products or rework charges) whether or not such damages are based on tort (including negligence), warranty, breach of contract or any other legal theory.

Notwithstanding any damages that customer might incur for any reason whatsoever, NXP Semiconductors' aggregate and cumulative liability towards customer for the products described herein shall be limited in accordance with the Terms and conditions of commercial sale of NXP Semiconductors.

Right to make changes — NXP Semiconductors reserves the right to make changes to information published in this document, including without limitation specifications and product descriptions, at any time and without notice. This document supersedes and replaces all information supplied prior to the publication hereof.

Applications — Applications that are described herein for any of these products are for illustrative purposes only. NXP Semiconductors makes no representation or warranty that such applications will be suitable for the specified use without further testing or modification.

Customers are responsible for the design and operation of their applications and products using NXP Semiconductors products, and NXP Semiconductors accepts no liability for any assistance with applications or customer product design. It is customer's sole responsibility to determine whether the NXP Semiconductors product is suitable and fit for the customer's applications and products planned, as well as for the planned application and use of customer's third party customer(s). Customers should provide appropriate design and operating safeguards to minimize the risks associated with their applications and products.

NXP Semiconductors does not accept any liability related to any default, damage, costs or problem which is based on any weakness or default in the customer's applications or products, or the application or use by customer's third party customer(s). Customer is responsible for doing all necessary testing for the customer's applications and products using NXP Semiconductors products in order to avoid a default of the applications and the products or of the application or use by customer's third party customer(s). NXP does not accept any liability in this respect.

Limiting values — Stress above one or more limiting values (as defined in the Absolute Maximum Ratings System of IEC 60134) will cause permanent damage to the device. Limiting values are stress ratings only and (proper) operation of the device at these or any other conditions above those given in the Recommended operating conditions section (if present) or the Characteristics sections of this document is not warranted. Constant or repeated exposure to limiting values will permanently and irreversibly affect the quality and reliability of the device.

Terms and conditions of commercial sale — NXP Semiconductors products are sold subject to the general terms and conditions of commercial sale, as published at <http://www.nxp.com/profile/terms>, unless otherwise agreed in a valid written individual agreement. In case an individual agreement is concluded only the terms and conditions of the respective agreement shall apply. NXP Semiconductors hereby expressly objects to applying the customer's general terms and conditions with regard to the purchase of NXP Semiconductors products by customer.

No offer to sell or license — Nothing in this document may be interpreted or construed as an offer to sell products that is open for acceptance or the grant, conveyance or implication of any license under any copyrights, patents or other industrial or intellectual property rights.

Quick reference data — The Quick reference data is an extract of the product data given in the Limiting values and Characteristics sections of this document, and as such is not complete, exhaustive or legally binding.

Export control — This document as well as the item(s) described herein may be subject to export control regulations. Export might require a prior authorization from competent authorities.

Translations — A non-English (translated) version of a document, including the legal information in that document, is for reference only. The English version shall prevail in case of any discrepancy between the translated and English versions.

Security — Customer understands that all NXP products may be subject to unidentified vulnerabilities or may support established security standards or specifications with known limitations. Customer is responsible for the design and operation of its applications and products throughout their lifecycles to reduce the effect of these vulnerabilities on customer's applications and products. Customer's responsibility also extends to other open and/or proprietary technologies supported by NXP products for use in customer's applications. NXP accepts no liability for any vulnerability. Customer should regularly check security updates from NXP and follow up appropriately.

Customer shall select products with security features that best meet rules, regulations, and standards of the intended application and make the ultimate design decisions regarding its products and is solely responsible for compliance with all legal, regulatory, and security related requirements concerning its products, regardless of any information or support that may be provided by NXP.

NXP has a Product Security Incident Response Team (PSIRT) (reachable at PSIRT@nxp.com) that manages the investigation, reporting, and solution release to security vulnerabilities of NXP products.

Suitability for use in automotive applications — This NXP product has been qualified for use in automotive applications. It has been developed in accordance with ISO 26262 and has been ASIL classified. If this product is used by customer in the development of, or for incorporation into, products or services (a) used in safety critical applications or (b) in which failure could lead to death, personal injury, or severe physical or environmental damage (such products and services hereinafter referred to as "Critical Applications"), then customer makes the ultimate design decisions regarding its products and is solely responsible for compliance with all legal, regulatory, safety, and security related requirements concerning its products, regardless of any information or support that may be provided by NXP. As such, customer assumes all risk related to use of any products in Critical Applications and NXP and its suppliers shall not be liable for any such use by customer. Accordingly, customer will indemnify and hold NXP harmless from any claims, liabilities, damages and associated costs and expenses (including attorneys' fees) that NXP may incur related to customer's incorporation of any product in a Critical Application.

Trademarks

Notice: All referenced brands, product names, service names, and trademarks are the property of their respective owners.

NXP — wordmark and logo are trademarks of NXP B.V.

AMBA, Arm, Arm7, Arm7TDMI, Arm9, Arm11, Artisan, big.LITTLE, Cordio, CoreLink, CoreSight, Cortex, DesignStart, DynamIQ, Jazelle, Keil, Mali, Mbed, Mbed Enabled, NEON, POP, RealView, SecurCore, Socrates, Thumb, TrustZone, ULINK, ULINK2, ULINK-ME, ULINK-PLUS, ULINKpro, μ Vision, Versatile — are trademarks or registered trademarks of Arm Limited (or its subsidiaries) in the US and/or elsewhere. The related technology may be protected by any or all of patents, copyrights, designs and trade secrets. All rights reserved.

Bluetooth — the Bluetooth wordmark and logos are registered trademarks owned by Bluetooth SIG, Inc. and any use of such marks by NXP Semiconductors is under license.

EdgeLock — is a trademark of NXP B.V.

elQ — is a trademark of NXP B.V.

I2C-bus — logo is a trademark of NXP B.V.

NXP SECURE CONNECTIONS FOR A SMARTER WORLD — is a trademark of NXP B.V.

SafeAssure — is a trademark of NXP B.V.

SafeAssure — logo is a trademark of NXP B.V.

SuperFlash This product uses SuperFlash[®]technology. SuperFlash[®] is a registered trademark of Silicon Storage Technology, Inc.

Synopsys & Designware — are registered trademarks of Synopsys, Inc.

Synopsys — Portions Copyright © 2021 Synopsys, Inc. Used with permission. All rights reserved.



arm

Please be aware that important notices concerning this document and the product(s) described herein, have been included in section 'Legal information'.

© NXP B.V. 2022.

All rights reserved.

For more information, please visit: <http://www.nxp.com>

For sales office addresses, please send an email to: salesaddresses@nxp.com

Date of release: 04/2022

Document identifier: S32K3XX