

# Distinctive Characteristics

Special bracket for right angle mounting provides added design variations.

Higher operating force type provides more pronounced operating feel.

Rubber seal construction prevents contact contamination and allows automated soldering and cleaning.

JB15FP model meets IP67 of IEC60529 specifications (similar to NEMA 4 & 13).

Choice of dimensions from PCB to top of cap allows design flexibility.

Dome contact gives crisp tactile feedback to positively indicate circuit transfer and assures high reliability and long life of up to 5,000,000 operations.

Slanted terminals provide a spring type action which ensures secure mounting and prevents dislodging during wave soldering.

Molded-in terminals are part of the sealed construction which allows automated soldering and washing.

Terminal spacing conforms to standard .100" (2.54mm) PCB grid.

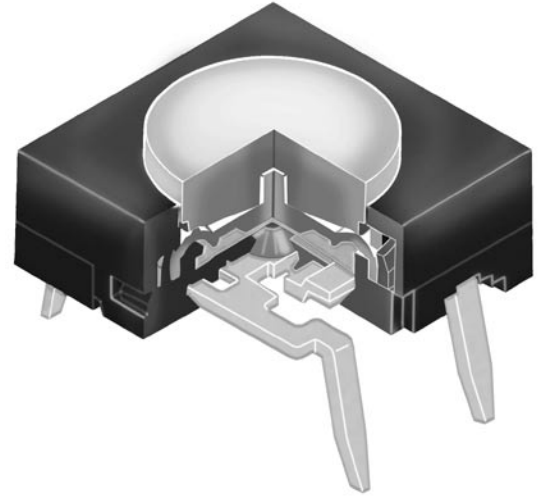

Actual Size

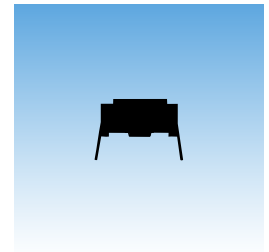

### KEYBOARD MATRIX

Common Bus Matrix

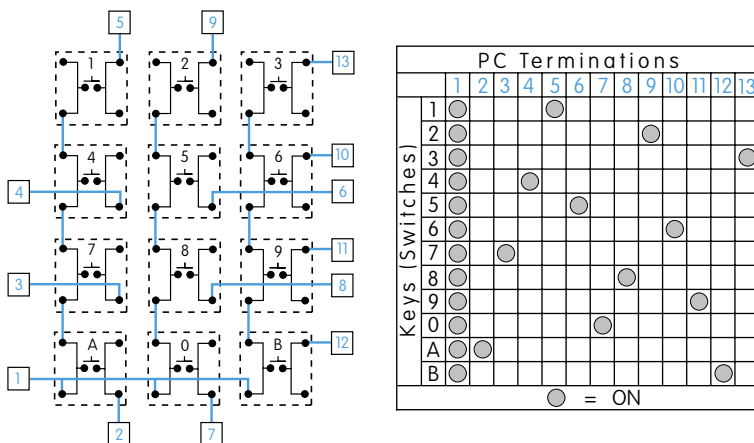

Blue = PCB Trace, Black = Switch Circuit

These single pole, single throw switches can be used in a keyboard matrix, and, using strapped terminals, achieve a common bus electrical configuration on a single-sided PC board.

X-Y Matrix

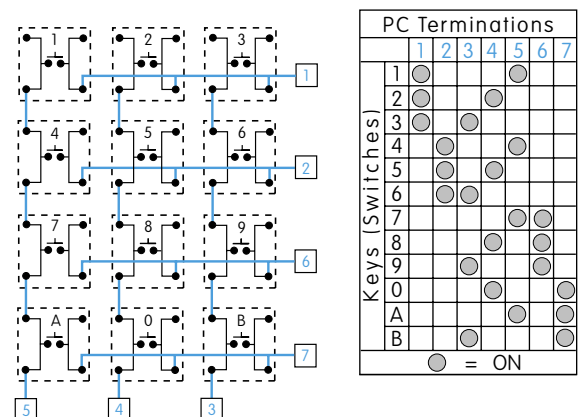

Blue = PCB Trace, Black = Switch Circuit

These single pole, single throw switches can be arranged on a single-sided PC board matrix with strapped terminals to achieve an X-Y type electrical interconnection.

# General Specifications

## Electrical Capacity (Resistive Load)

**Low Level:** 50mA @ 24V DC maximum for Standard Operating Force models  
125mA @ 24V DC maximum for High Operating Force models

## Other Ratings

	<b>Standard Operating Force</b>	<b>High Operating Force</b>
<b>Contact Resistance:</b>	50 milliohms maximum	50 milliohms maximum
<b>Insulation Resistance:</b>	500 megohms minimum @ 250V DC	500 megohms minimum @ 250V DC
<b>Dielectric Strength:</b>	250V AC minimum for 1 minute minimum	250V AC minimum for 1 minute minimum
<b>Mechanical Life:</b>	5,000,000 operations minimum	1,000,000 operations minimum
<b>Electrical Life:</b>	5,000,000 operations minimum	1,000,000 operations minimum
<b>Nominal Operating Force:</b>	1.76N for JB15	2.65N for JB15H
<b>Total Travel:</b>	.010" (.250mm)	.012" (.300mm)

## Materials & Finishes

<b>Actuator:</b>	Glass fiber reinforced PBT for Extended actuator; PBT for Flat; Polyacetal for Short
<b>Case:</b>	Glass fiber reinforced polyamide (UL94V-0)
<b>Seal:</b>	Nitrile butadiene rubber
<b>Base:</b>	Glass fiber reinforced PBT (UL94V-0)
<b>Movable Contacts:</b>	Beryllium copper with silver plating
<b>Stationary Contacts:</b>	Brass with silver plating
<b>Terminals:</b>	Brass with silver plating
<b>Mounting Bracket:</b>	Phosphor bronze with tin plating

## Environmental Data

<b>Operating Temperature Range:</b>	-25°C through +70°C (-13°F through +158°F)
<b>Humidity:</b>	90 ~ 95% humidity for 240 hours @ 40°C (104°F)
<b>Vibration:</b>	10 ~ 55Hz with peak-to-peak amplitude of 1.5mm traversing the frequency range & returning in 1 minute; 3 right angled directions for 2 hours
<b>Shock:</b>	50G (490m/s <sup>2</sup> ) acceleration (tested in 6 right angled directions, with 5 shocks in each direction)
<b>Sealing:</b>	IP67 of IEC60529 standard (similar to NEMA 4 & 13)

## PCB Processing

<b>Soldering:</b>	Wave Soldering Recommended. See Profile A in Supplement section. Manual Soldering: See Profile A in Supplement section.
<b>Cleaning:</b>	Automated cleaning. See Cleaning specifications in Supplement section.

## Standards & Certifications

<b>Flammability Standards:</b>	UL94V-0 rated case & base
<b>UL Recognition or CSA Certification:</b>	The JB Series tactiles have not been tested for UL recognition or CSA certification. These switches are designed for use in a low-voltage, low-current, logic-level circuit. When used as intended in a logic-level circuit, the results do not produce hazardous energy.

### TYPICAL SWITCH ORDERING EXAMPLE

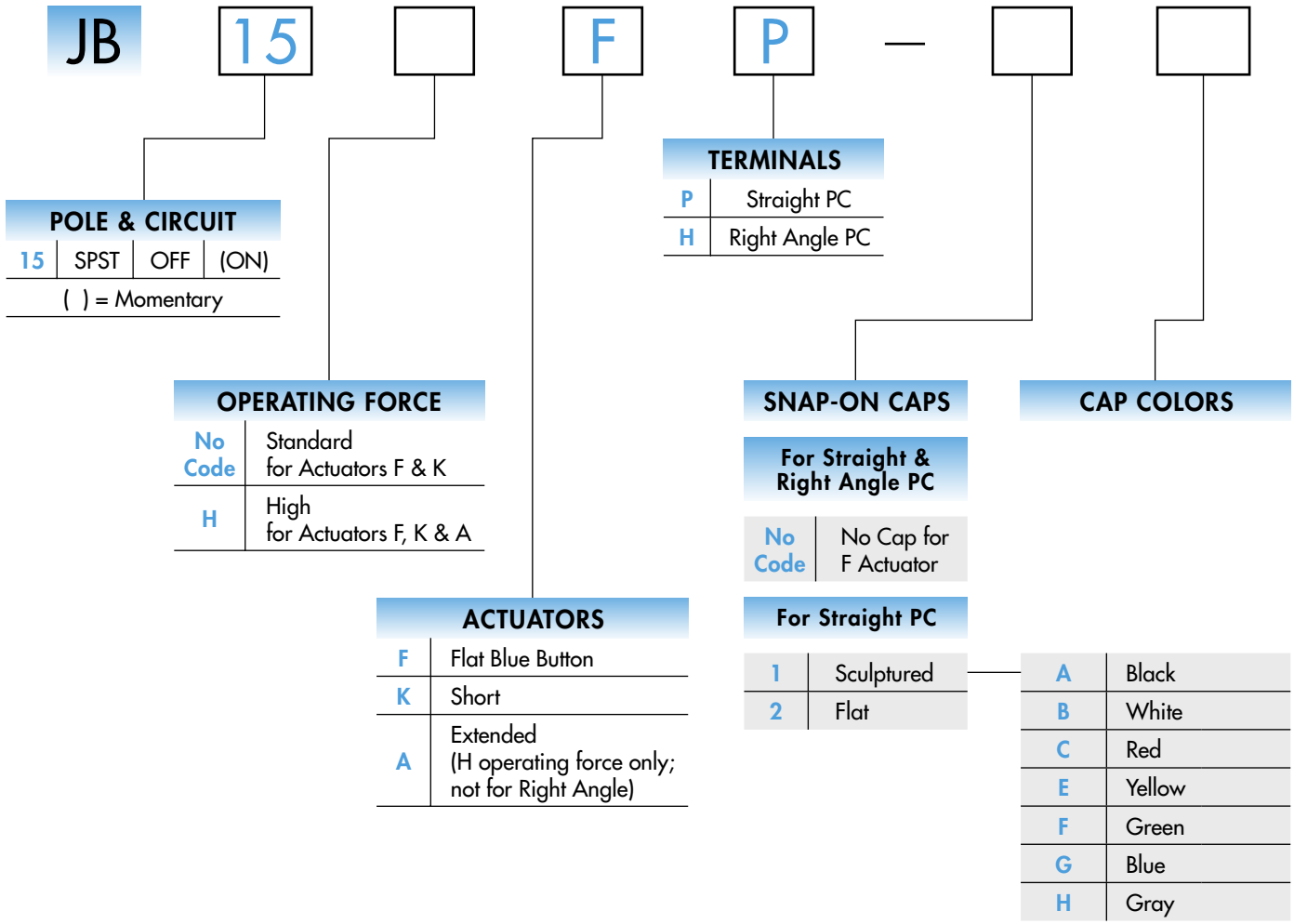

### DESCRIPTION FOR TYPICAL ORDERING EXAMPLE

#### JB15FP

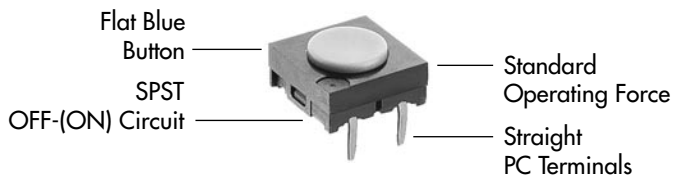

<b>4</b>	Framed	<b>Button</b>		<b>Frame</b>	
<b>B</b>	White	<b>B</b>			
<b>C</b>	Red	<b>C</b>			
<b>E</b>	Yellow	<b>E</b>			
<b>F</b>	Green	<b>F</b>			
<b>G</b>	Blue	<b>G</b>			
<b>H</b>	Gray	<b>H</b>			

<b>5</b>	Cap with Black Mounter	<b>A</b>	Black
		<b>B</b>	White
		<b>C</b>	Red
		<b>H</b>	Gray

**For Right Angle PC**

<b>6</b>	Flat	<b>A</b>	Black
		<b>B</b>	White
		<b>C</b>	Red
		<b>H</b>	Gray

### POLE & CIRCUIT

		Actuator Position ( ) = Momentary		Switch Throw & Schematic	Note: Terminal numbers are shown on the switch.
Pole	Model	Normal	Down		
				SPST	
SP	JB15	OFF	(ON)		

### OPERATING FORCE

No  
Code

#### Standard Operating Force

1.76N

For F & K Actuators

H

#### High Operating Force

2.65N

For F, K & A Actuators

### ACTUATORS

F

#### Flat Blue Button

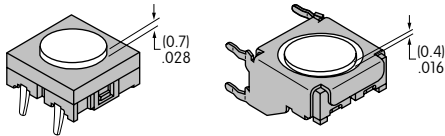

Flat button is an integral part of the switch and cannot be ordered separately.

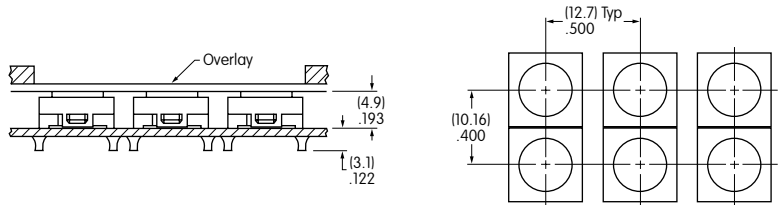

Custom keyboards can be designed with flat buttons beneath an overlay. Not applicable for right angle mounting.

K

#### Short Actuator

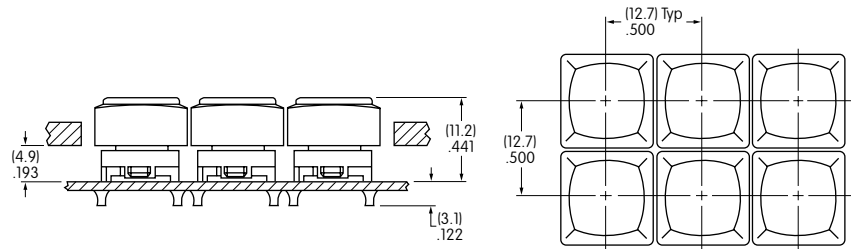
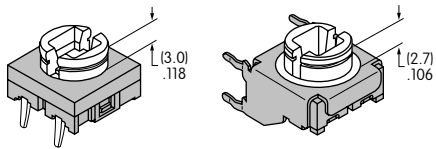

Custom keyboards can be designed with caps installed through a panel cutout (illustration with framed cap AT4078 and button AT4077). Not applicable for right angle mounting.

A

#### Extended Actuator

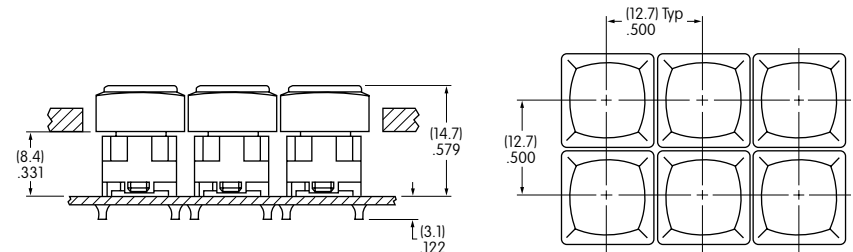
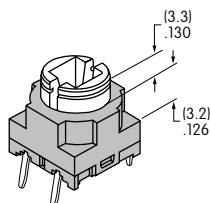

Combines with high operating force only; not for right angle.

Custom keyboards can be designed with caps installed through a panel cutout (illustration with framed cap AT4078 and button AT4077).

### TERMINALS

#### P Straight PC

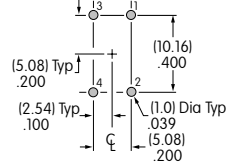
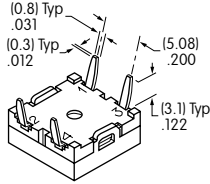

#### H Right Angle PC

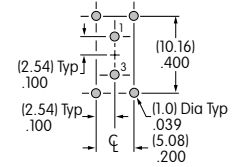
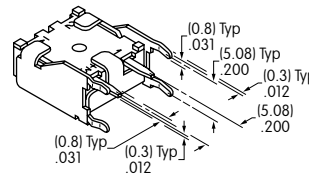

Further details shown in Typical Switch Dimensions

### SNAP-ON CAPS

#### 1 AT4058 Sculptured for Straight PC

Material: Polyamide  
Finish: Matte  
Colors: A B C E F G H

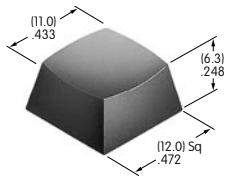

#### 2 AT4059 Flat for Straight PC

Material: Polycarbonate  
Finish: Glossy  
Colors: A B C E F G H

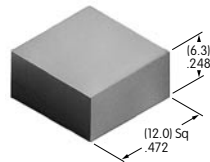

#### 4 Framed: AT4077 Button & AT4078 Frame for Straight PC

Material: Polycarbonate  
Finish: Matte  
Colors: B C E F G H

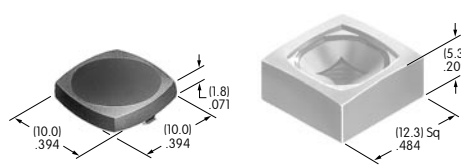

#### 6 AT4139 Flat for Right Angle PC

Material: Polycarbonate  
Finish: Glossy  
Colors: A B C H

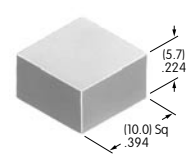

#### 5 AT4140 Cap with AT547 Mounter for Straight PC

Cap  
Material: Polycarbonate  
Finish: Glossy  
Colors: A B C H

Mounter  
Material: Polyamide  
Finish: Matte  
Color: A

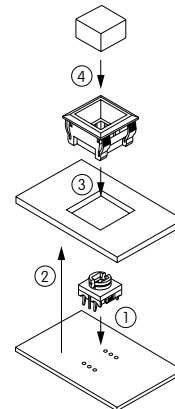

#### Assembly Procedure

1. Solder switch to PCB.
2. Install PCB in equipment.
3. Snap mounter into panel. Dimension from top of panel to top of PCB is .386" (9.8mm).
4. Snap cap onto plunger.

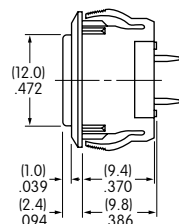
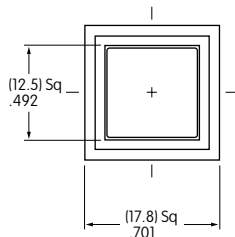

#### Panel Mounting Dimensions

Panel Thickness:  
.039" ~ .079"  
(1.0mm ~ 2.0mm)

#### Panel Cutout & Footprint

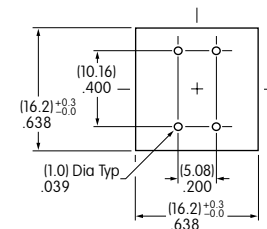

Cap Colors Available:

**A** Black

**B** White

**C** Red

**E** Yellow

**F** Green

**G** Blue

**H** Gray

### TYPICAL SWITCH DIMENSIONS

#### Flat Blue Button • Straight PC

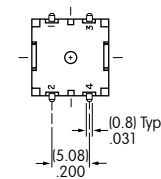
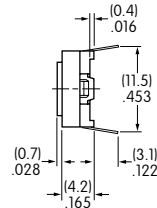
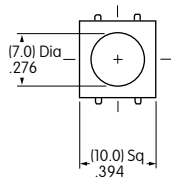

JB15FP

Spring action terminals conform to .100" (2.54mm) PCB spacing

#### Flat Blue Button • Right Angle PC

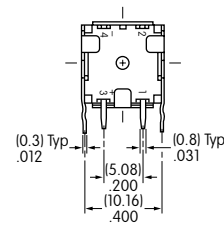
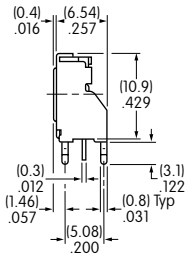
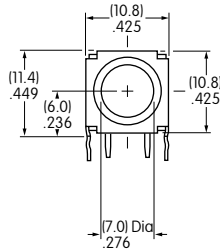

JB15FH

#### Sculptured Snap-on Cap • Straight PC

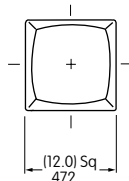

#### Short Actuator

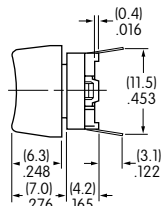

#### Extended Actuator

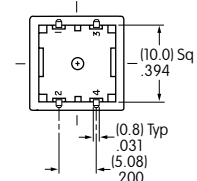
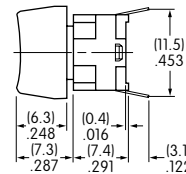

JB15KP-1C

Spring action terminals conform to .100" (2.54mm) PCB spacing

#### Flat Snap-on Cap • Straight PC

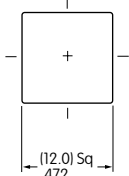

#### Short Actuator

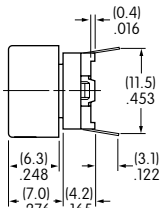

#### Extended Actuator

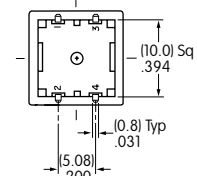
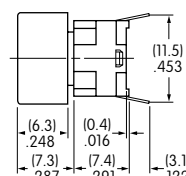

JB15KP-2C

Spring action terminals conform to .100" (2.54mm) PCB spacing

#### Framed Snap-on Cap • Straight PC

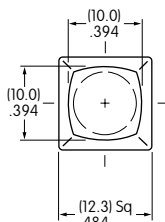

#### Short Actuator

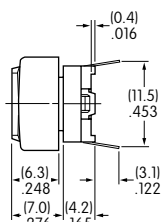

#### Extended Actuator

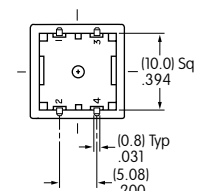
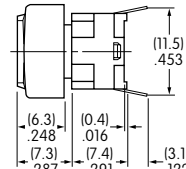

JB15FHAP-4BC

Spring action terminals conform to .100" (2.54mm) PCB spacing

### TYPICAL SWITCH DIMENSIONS

#### Flat Snap-on Cap • Right Angle PC

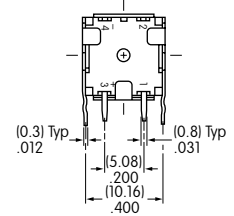
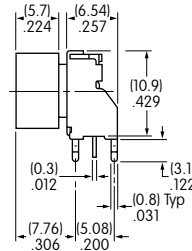
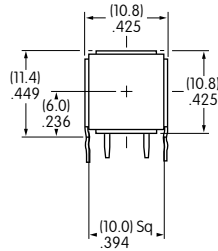

JB15KH-6C

### LEGENDS

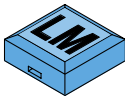

Easily create and submit your own legends using our new on-line Legend Maker.

Visit [www.nkkswitches.com](http://www.nkkswitches.com)

For other legend support options, customers may either contact the factory and request the JB Legend Packet, or utilize the general information and basic specifications presented below.

#### Shaded Areas are Printable Areas

AT4058

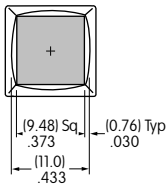
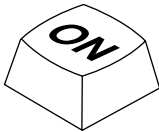

AT4059 & AT4140

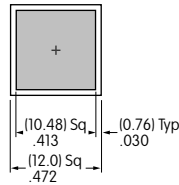
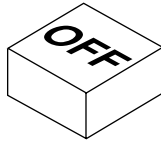

AT4077 Button

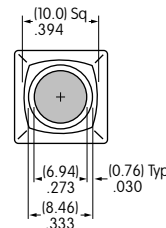
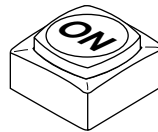

AT4139

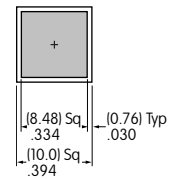
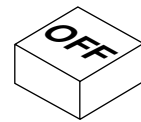

**Recommended Print Method:** Screen Print or Pad Print. Epoxy based ink is recommended.

#### Additional Method

An additional method for legends is engraving the cap. Maximum depth for engraving is .012" (0.3mm) on the cap. Enamel paint is recommended to fill the engraved area.