

HPC16083/HPC26083/HPC36083/HPC46083/ HPC16003/HPC26003/HPC36003/HPC46003 High-Performance microControllers

General Description

The HPC16083 and HPC16003 are members of the HPC™ family of High Performance microControllers. Each member of the family has the same core CPU with a unique memory and I/O configuration to suit specific applications. The HPC16083 has 8k bytes of on-chip ROM. The HPC16003 has no on-chip ROM and is intended for use with external direct memory. Each part is fabricated in National's advanced microCMOS technology. This process combined with an advanced architecture provides fast, flexible I/O control, efficient data manipulation, and high speed computation.

The HPC devices are complete microcomputers on a single chip. All system timing, internal logic, ROM, RAM, and I/O are provided on the chip to produce a cost effective solution for high performance applications. On-chip functions such as UART, up to eight 16-bit timers with 4 input capture registers, vectored interrupts, WATCHDOG™ logic and MICROWIRE/PLUS™ provide a high level of system integration. The ability to address up to 64k bytes of external memory enables the HPC to be used in powerful applications typically performed by microprocessors and expensive peripheral chips. The term "HPC16083" is used throughout this data-sheet to refer to the HPC16083 and HPC16003 devices unless otherwise specified.

The microCMOS process results in very low current drain and enables the user to select the optimum speed/power product for his system. The IDLE and HALT modes provide further current savings. The HPC is available in 68-pin PLCC, LDCC, PGA and 80-Pin PQFP packages.

Features

- HPC family—core features:
 - 16-bit architecture, both byte and word
 - 16-bit data bus, ALU, and registers
 - 64k bytes of external direct memory addressing
 - FAST—200 ns for fastest instruction when using 20.0 MHz clock, 134 ns at 30 MHz
 - High code efficiency—most instructions are single byte
 - 16 x 16 multiply and 32 x 16 divide
 - Eight vectored interrupt sources
 - Four 16-bit timer/counters with 4 synchronous outputs and WATCHDOG logic
 - MICROWIRE/PLUS serial I/O interface
 - CMOS—very low power with two power save modes: IDLE and HALT
- UART—full duplex, programmable baud rate
- Four additional 16-bit timer/counters with pulse width modulated outputs
- Four input capture registers
- 52 general purpose I/O lines (memory mapped)
- 8k bytes of ROM, 256 bytes of RAM on chip
- ROMless version available (HPC16003)
- Commercial (0°C to +70°C), industrial (-40°C to +85°C), automotive (-40°C to +105°C) and military (-55°C to +125°C) temperature ranges

For applications requiring more RAM and ROM see HPC16064 data sheet.

Block Diagram (HPC16083 with 8k ROM shown)

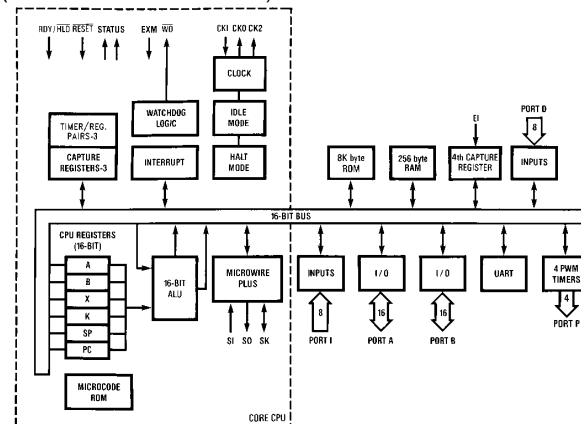

TL/DD/8801-1

Series 32000®, TapePak® and TRI-STATE® are registered trademarks of National Semiconductor Corporation.
MOLE™, HPC™, COPSTM, MICROWIRE/PLUS™ and WATCHDOG™ are trademarks of National Semiconductor Corporation.
UNIX® is a registered trademarks of AT&T Bell Laboratories.
VAX™ is a trademark of Digital Equipment Corporation.
IBM® and PC/AT® are registered trademarks of International Business Machines Corporation.
SUN® is a registered trademark of Sun Microsystems.
SunOST™ is a trademark of Sun Microsystems.

HPC16083/HPC26083/HPC36083/HPC46083/HPC16003/HPC26003/HPC36003/HPC46003 High-Performance microControllers

Absolute Maximum Ratings

If Military/Aerospace specified devices are required, please contact the National Semiconductor Sales Office/Distributors for availability and specifications.

Total Allowable Source or Sink Current	100 mA
Storage Temperature Range	-65°C to +150°C
Lead Temperature (Soldering, 10 sec)	300°C

V_{CC} with Respect to GND -0.5V to 7.0V
All Other Pins ($V_{CC} + 0.5$)V to (GND - 0.5)V

Note: Absolute maximum ratings indicate limits beyond which damage to the device may occur. DC and AC electrical specifications are not ensured when operating the device at absolute maximum ratings.

DC Electrical Characteristics $V_{CC} = 5.0V \pm 10\%$ unless otherwise specified, $T_A = 0^\circ C$ to $+70^\circ C$
HPC46083/HPC46003, -40°C to +85°C for HPC36083/HPC36003, -40°C to +105°C for
HPC26083/HPC26003, -55°C to +125°C for HPC16083/HPC16003

Symbol	Parameter	Test Conditions	Min	Max	Units
I_{CC1}	Supply Current	$V_{CC} = 5.5V, f_{in} = 30$ MHz (Note 1)		65	mA
		$V_{CC} = 5.5V, f_{in} = 20$ MHz (Note 1)		47	mA
		$V_{CC} = 5.5V, f_{in} = 2.0$ MHz (Note 1)		10	mA
I_{CC2}	IDLE Mode Current	$V_{CC} = 5.5V, f_{in} = 30$ MHz (Note 1)		5.0	mA
		$V_{CC} = 5.5V, f_{in} = 20$ MHz, (Note 1)		3.0	mA
		$V_{CC} = 5.5V, f_{in} = 2.0$ MHz, (Note 1)		1	mA
I_{CC3}	HALT Mode Current	$V_{CC} = 5.5V, f_{in} = 0$ kHz, (Note 1)		200	μA
		$V_{CC} = 2.5V, f_{in} = 0$ kHz, (Note 1)		50	μA

INPUT VOLTAGE LEVELS FOR SCHMITT TRIGGERED INPUTS RESET, NMI AND \overline{WO} ; AND ALSO CKI

V_{IH1}	Logic High		$0.9 V_{CC}$		V
V_{IL1}	Logic Low			$0.1 V_{CC}$	V

INPUT VOLTAGE LEVELS FOR ALL OTHER INPUTS

V_{IH2}	Logic High		$0.7 V_{CC}$		V
V_{IL2}	Logic Low			$0.2 V_{CC}$	V
I_{LI1}	Input Leakage Current	$V_{IN} = 0$ and $V_{IN} = V_{CC}$		± 2	μA
I_{LI2}	Input Leakage Current RDY/HLD, EXUI	$V_{IN} = 0$	-3	-50	μA
I_{LI3}	Input Leakage Current B12	$\overline{RESET} = 0, V_{IN} = V_{CC}$	0.5	7	mA
C_I	Input Capacitance	(Note 2)		10	pF
C_{IO}	I/O Capacitance	(Note 2)		20	pF

OUTPUT VOLTAGE LEVELS

V_{OH1}	Logic High (CMOS)	$I_{OH} = -10 \mu A$ (Note 2)	$V_{CC} - 0.1$		V
V_{OL1}	Logic Low (CMOS)	$I_{OH} = 10 \mu A$ (Note 2)		0.1	V
V_{OH2}	Port A/B Drive, CK2 (A ₀ -A ₁₅ , B ₁₀ , B ₁₁ , B ₁₂ , B ₁₅)	$I_{OH} = -7$ mA	2.4		V
V_{OL2}		$I_{OL} = 3$ mA		0.4	V
V_{OH3}	Other Port Pin Drive, \overline{WO} (open drain), (B ₀ -B ₉ , B ₁₃ , B ₁₄ , P ₀ -P ₃)	$I_{OH} = -1.6$ mA (except \overline{WO})	2.4		V
V_{OL3}		$I_{OL} = 0.5$ mA		0.4	V
V_{OH4}	ST1 and ST2 Drive	$I_{OH} = -6$ mA	2.4		V
V_{OL4}		$I_{OL} = 1.6$ mA		0.4	V
V_{OH5}	Port A/B Drive (A ₀ -A ₁₅ , B ₁₀ , B ₁₁ , B ₁₂ , B ₁₅) when used as External Address/Data Bus	$I_{OH} = -1$ mA	2.4		V
V_{OL5}		$I_{OL} = 3$ mA		0.4	V
V_{RAM}	RAM Keep-Alive Voltage	(Note 3)	2.5	V_{CC}	V
I_{OZ}	TRI-STATE® Leakage Current	$V_{IN} = 0$ and $V_{IN} = V_{CC}$		± 5	μA

Note 1: I_{CC1} , I_{CC2} , I_{CC3} measured with no external drive (I_{OH} and $I_{OL} = 0$, I_{IH} and $I_{IL} = 0$). I_{CC1} is measured with $\overline{RESET} = V_{SS}$. I_{CC3} is measured with $NMI = V_{CC}$. CKI driven to V_{IH1} and V_{IL1} , with rise and fall times less than 10 ns.

Note 2: This is guaranteed by design and not tested.

Note 3: Test duration is 100 ms.

20 MHz

AC Electrical Characteristics

(See Notes 1 and 4 and Figure 1 thru Figure 5) $V_{CC} = 5.0V \pm 10\%$ unless otherwise specified, $T_A = 0^\circ C$ to $+70^\circ C$ for HPC46083/HPC46003, $-40^\circ C$ to $+85^\circ C$ for HPC36083/HPC36003, $-40^\circ C$ to $+105^\circ C$ for HPC26083/HPC26003, $-55^\circ C$ to $+125^\circ C$ for HPC16083/HPC16003

	Symbol and Formula	Parameter	Min	Max	Units	Note
Clocks	f_C	CKI Operating Frequency	2	20	MHz	
	$t_{C1} = 1/f_C$	CKI Clock Period	50	500	ns	
	t_{CKIH}	CKI High Time	22.5		ns	
	t_{CKIL}	CKI Low Time	22.5		ns	
	$t_C = 2/f_C$	CPU Timing Cycle	100		ns	
	$t_{WAIT} = t_C$	CPU Wait State Period	100		ns	
	t_{DC1C2R}	Delay of CK2 Rising Edge after CKI Falling Edge	0	55	ns	(Note 2)
	t_{DC1C2F}	Delay of CK2 Falling Edge after CKI Falling Edge	0	55	ns	(Note 2)
		$f_U = f_C/8$	External UART Clock Input Frequency		2.5**	MHz
	f_{MW}	External MICROWIRE/PLUS Clock Input Frequency		1.25	MHz	
Timers	$f_{XIN} = f_C/22$	External Timer Input Frequency		0.91	MHz	
	$t_{XIN} = t_C$	Pulse Width for Timer Inputs	100		ns	
MICROWIRE/ PLUS	t_{UWS}	MICROWIRE Setup Time—Master —Slave	100 20		ns	
	t_{UWH}	MICROWIRE Hold Time—Master —Slave	20 50		ns	
	t_{UWV}	MICROWIRE Output Valid Time—Master —Slave		50 150	ns	
External Hold	$t_{SALE} = \frac{3}{4} t_C + 40$	\overline{HLD} Falling Edge before ALE Rising Edge	115		ns	
	$t_{HWP} = t_C + 10$	\overline{HLD} Pulse Width	110		ns	
	$t_{HAE} = t_C + 100$	\overline{HLDA} Falling Edge after \overline{HLD} Falling Edge		200	ns	(Note 3)
	$t_{HAD} = \frac{3}{4} t_C + 85$	\overline{HLDA} Rising Edge after \overline{HLD} Rising Edge		160	ns	
	$t_{BF} = \frac{1}{2} t_C + 66$	Bus Float after \overline{HLDA} Falling Edge		116	ns	(Note 5)
	$t_{BE} = \frac{1}{2} t_C + 66$	Bus Enable after \overline{HLDA} Rising Edge	116		ns	(Note 5)
UPI Timing	t_{UAS}	Address Setup Time to Falling Edge of \overline{URD}	10		ns	
	t_{UAH}	Address Hold Time from Rising Edge of \overline{URD}	10		ns	
	t_{RPW}	\overline{URD} Pulse Width	100		ns	
	t_{OE}	\overline{URD} Falling Edge to Output Data Valid	0	60	ns	
	t_{OD}	Rising Edge of \overline{URD} to Output Data Invalid	5	35	ns	(Note 6)
	t_{DRDY}	\overline{RDRDY} Delay from Rising Edge of \overline{URD}		70	ns	
	t_{WDW}	\overline{UWR} Pulse Width	40		ns	
	t_{UDS}	Input Data Valid before Rising Edge of \overline{UWR}	10		ns	
	t_{UDH}	Input Data Hold after Rising Edge of \overline{UWR}	20		ns	
	t_A	\overline{WRDY} Delay from Rising Edge of \overline{UWR}		70	ns	

**This maximum frequency is attainable provided that this external baud clock has a duty cycle such that the high period includes two (2) falling edges of the CK2 clock.

20 MHz

AC Electrical Characteristics

(See Notes 1 and 4 and Figure 1 thru Figure 5) $V_{CC} = 5.0V \pm 10\%$ unless otherwise specified, $T_A = 0^\circ C$ to $+70^\circ C$ for HPC46083/HPC46003, $-40^\circ C$ to $+85^\circ C$ for HPC36083/HPC36003, $-40^\circ C$ to $+105^\circ C$ for HPC26083/HPC26003, $-55^\circ C$ to $+125^\circ C$ for HPC16083/HPC16003 (Continued)

	Symbol and Formula	Parameter	Min	Max	Units	Note
Address Cycles	$t_{DC1ALER}$	Delay from CK1 Rising Edge to ALE Rising Edge	0	35	ns	(Notes 1, 2)
	$t_{DC1ALEF}$	Delay from CK1 Rising Edge to ALE Falling Edge	0	35	ns	(Notes 1, 2)
	$t_{DC2ALER} = \frac{1}{4} t_C + 20$	Delay from CK2 Rising Edge to ALE Rising Edge		45	ns	(Note 2)
	$t_{DC2ALEF} = \frac{1}{4} t_C + 20$	Delay from CK2 Rising Edge to ALE Falling Edge		45	ns	(Note 2)
	$t_{LL} = \frac{1}{2} t_C - 9$	ALE Pulse Width	41		ns	
	$t_{ST} = \frac{1}{4} t_C - 7$	Setup of Address Valid before ALE Falling Edge	18		ns	
	$t_{VP} = \frac{1}{4} t_C - 5$	Hold of Address Valid after ALE Falling Edge	20		ns	
Read Cycles	$t_{ARR} = \frac{1}{4} t_C - 5$	ALE Falling Edge to \overline{RD} Falling Edge	20		ns	
	$t_{ACC} = t_C + WS - 55$	Data Input Valid after Address Output Valid		145	ns	(Note 6)
	$t_{RD} = \frac{1}{2} t_C + WS - 65$	Data Input Valid after \overline{RD} Falling Edge		95	ns	
	$t_{RW} = \frac{1}{2} t_C + WS - 10$	\overline{RD} Pulse Width	140		ns	
	$t_{DR} = \frac{3}{4} t_C - 15$	Hold of Data Input Valid after \overline{RD} Rising Edge	0	60	ns	
	$t_{RDA} = t_C - 15$	Bus Enable after \overline{RD} Rising Edge	85		ns	
Write Cycles	$t_{ARW} = \frac{1}{2} t_C - 5$	ALE Falling Edge to \overline{WR} Falling Edge	45		ns	
	$t_{WW} = \frac{3}{4} t_C + WS - 15$	\overline{WR} Pulse Width	160		ns	
	$t_V = \frac{1}{2} t_C + WS - 5$	Data Output Valid before \overline{WR} Rising Edge	145		ns	
	$t_{HW} = \frac{1}{4} t_C - 5$	Hold of Data Valid after \overline{WR} Rising Edge	20		ns	
Ready Input	$t_{DAR} = \frac{1}{4} t_C + WS - 50$	Falling Edge of ALE to Falling Edge of RDY		75	ns	
	$t_{RWP} = t_C$	RDY Pulse Width	100		ns	

Note: $C_L = 40$ pF.

Note 1: These AC characteristics are guaranteed with external clock drive on CK1 having 50% duty cycle and with less than 15 pF load on CK0 with rise and fall times (t_{CKIR} and t_{CKIL}) on CK1 input less than 2.5 ns.

Note 2: Do not design with these parameters unless CK1 is driven with an active signal. When using a passive crystal circuit, its stability is not guaranteed if either CK1 or CK0 is connected to any external logic other than the passive components of the crystal circuit.

Note 3: t_{HAE} is spec'd for case with \overline{HLD} falling edge occurring at the latest time it can be accepted during the present CPU cycle being executed. If \overline{HLD} falling edge occurs later, t_{HAE} as long as $(3t_C + 4WS + 72t_C + 100)$ may occur depending on the following CPU instruction cycles, its wait state and ready input.

Note 4: WS (t_{WAIT}) x (number of preprogrammed wait states). Minimum and maximum values are calculated at maximum operating frequency, $t_C = 20$ MHz, with one wait programmed.

Note 5: Due to emulation restrictions—actual limits will be better.

Note 6: This is guaranteed by design and not tested.

30 MHz

AC Electrical Characteristics (Continued)

(See Notes 1 and 4 and Figure 1 thru Figure 5) $V_{CC} = 5.0V \pm 10\%$ unless otherwise specified, $T_A = 0^\circ C$ to $+70^\circ C$ for HPC46083/HPC46003, $-40^\circ C$ to $+85^\circ C$ for HPC36083/HPC36003, $-40^\circ C$ to $+105^\circ C$ for HPC26083/HPC26003, $-55^\circ C$ to $+125^\circ C$ for HPC16083/HPC16003

	Symbol and Formula	Parameter	Min	Max	Units	Note
Clocks	f_C	CKI Operating Frequency	2	30	MHz	
	$t_{C1} = 1/f_C$	CKI Clock Period	33	500	ns	
	t_{CKIH}	CKI High Time	15		ns	
	t_{CKIL}	CKI Low Time	16.6		ns	
	$t_C = 2/f_C$	CPU Timing Cycle	66		ns	
	$t_{WAIT} = t_C$	CPU Wait State Period	66		ns	
	t_{DC1C2R}	Delay of CK2 Rising Edge after CKI Falling Edge	0	55	ns	(Note 2)
	t_{DC1C2F}	Delay of CK2 Falling Edge after CKI Falling Edge	0	55	ns	(Note 2)
	$f_U = f_C/8$	External UART Clock Input Frequency		3.75**	MHz	
f_{MW}	External MICROWIRE/PLUS Clock Input Frequency		1.875	MHz		
Timers	$f_{XIN} = f_C/22$	External Timer Input Frequency		1.364	MHz	
	$t_{XIN} = t_C$	Pulse Width for Timer Inputs	66		ns	
MICROWIRE/ PLUS	t_{UWS}	MICROWIRE Setup Time—Master —Slave	100 20		ns	
	t_{UWH}	MICROWIRE Hold Time—Master —Slave	20 50		ns	
	t_{UWV}	MICROWIRE Output Valid Time—Master —Slave		50 150	ns	
External Hold	$t_{SALE} = \frac{3}{4} t_C + 40$	\overline{HLD} Falling Edge before ALE Rising Edge	90		ns	
	$t_{HWP} = t_C + 10$	\overline{HLD} Pulse Width	76		ns	
	$t_{HAE} = t_C + 85$	\overline{HLDA} Falling Edge after \overline{HLD} Falling Edge		151	ns	(Note 3)
	$t_{HAD} = \frac{3}{4} t_C + 85$	\overline{HLDA} Rising Edge after \overline{HLD} Rising Edge		135	ns	
	$t_{BF} = \frac{1}{2} t_C + 66$	Bus Float after \overline{HLDA} Falling Edge		99	ns	(Note 5)
	$t_{BE} = \frac{1}{2} t_C + 66$	Bus Enable after \overline{HLDA} Rising Edge	99		ns	(Note 5)
UPI Timing	t_{UAS}	Address Setup Time to Falling Edge of \overline{URD}	10		ns	
	t_{UAH}	Address Hold Time from Rising Edge of \overline{URD}	10		ns	
	t_{RPW}	\overline{URD} Pulse Width	100		ns	
	t_{OE}	\overline{URD} Falling Edge to Output Data Valid	0	60	ns	
	t_{OD}	Rising Edge of \overline{URD} to Output Data Invalid	5	35	ns	(Note 6)
	t_{DRDY}	\overline{RDRDY} Delay from Rising Edge of \overline{URD}		70	ns	
	t_{WDW}	\overline{UWR} Pulse Width	40		ns	
	t_{UDS}	Input Data Valid before Rising Edge of \overline{UWR}	10		ns	
	t_{UDH}	Input Data Hold after Rising Edge of \overline{UWR}	15		ns	
	t_A	\overline{WRRDY} Delay from Rising Edge of \overline{UWR}		70	ns	

**This maximum frequency is attainable provided that this external baud clock has a duty cycle such that the high period includes two (2) falling edges of the CK2 clock.

30 MHz

AC Electrical Characteristics

(See Notes 1 and 4 and Figure 1 thru Figure 5) $V_{CC} = 5.0V \pm 10\%$ unless otherwise specified, $T_A = 0^\circ C$ to $+70^\circ C$ for HPC46083/HPC46003, $-40^\circ C$ to $+85^\circ C$ for HPC36083/HPC36003, $-40^\circ C$ to $+105^\circ C$ for HPC26083/HPC26003, $-55^\circ C$ to $+125^\circ C$ for HPC16083/HPC16003 (Continued)

	Symbol and Formula	Parameter	Min	Max	Units	Notes
Address Cycles	$t_{DC1ALER}$	Delay from CK1 Rising Edge to ALE Rising Edge	0	35	ns	(Notes 1, 2)
	$t_{DC1ALEF}$	Delay from CK1 Rising Edge to ALE Falling Edge	0	35	ns	(Notes 1, 2)
	$t_{DC2ALER} = \frac{1}{4} t_C + 20$	Delay from CK2 Rising Edge to ALE Rising Edge		37	ns	(Note 2)
	$t_{DC2ALEF} = \frac{1}{4} t_C + 20$	Delay from CK2 Falling Edge to ALE Falling Edge		37	ns	(Note 2)
	$t_{LL} = \frac{1}{2} t_C - 9$	ALE Pulse Width	24		ns	
	$t_{ST} = \frac{1}{4} t_C - 7$	Setup of Address Valid before ALE Falling Edge	9		ns	
Read Cycles	$t_{VP} = \frac{1}{4} t_C - 5$	Hold of Address Valid after ALE Falling Edge	11		ns	
	$t_{ARR} = \frac{1}{4} t_C - 5$	ALE Falling Edge to \overline{RD} Falling Edge	12		ns	
	$t_{ACC} = t_C + WS - 32$	Data Input Valid after Address Output Valid		100	ns	(Note 6)
	$t_{RD} = \frac{1}{2} t_C + WS - 39$	Data Input Valid after \overline{RD} Falling Edge		60	ns	
	$t_{RW} = \frac{1}{2} t_C + WS - 14$	\overline{RD} Pulse Width	85		ns	
	$t_{DR} = \frac{3}{4} t_C - 15$	Hold of Data Input Valid after \overline{RD} Rising Edge	0	35	ns	
Write Cycles	$t_{RDA} = t_C - 15$	Bus Enable after \overline{RD} Rising Edge	51		ns	
	$t_{ARW} = \frac{1}{2} t_C - 5$	ALE Falling Edge to \overline{WR} Falling Edge	28		ns	
	$t_{WW} = \frac{3}{4} t_C + WS - 15$	\overline{WR} Pulse Width	101		ns	
Ready Input	$t_V = \frac{1}{2} t_C + WS - 5$	Data Output Valid before \overline{WR} Rising Edge	94		ns	
	$t_{HW} = \frac{1}{4} t_C - 10$	Hold of Data Valid after \overline{WR} Rising Edge	7		ns	
Ready Input	$t_{DAR} = \frac{1}{4} t_C + WS - 50$	Falling Edge of ALE to Falling Edge of RDY		33	ns	
	$t_{RWP} = t_C$	RDY Pulse Width	66		ns	

Note: $C_L = 40$ pF.

Note 1: These AC characteristics are guaranteed with external clock drive on CK1 having 50% duty cycle and with less than 15 pF load on CKO with rise and fall times (t_{CKIR} and t_{CKIL}) on CK1 input less than 2.5 ns.

Note 2: Do not design with these parameters unless CK1 is driven with an active signal. When using a passive crystal circuit, its stability is not guaranteed if either CK1 or CK0 is connected to any external logic other than the passive components of the crystal circuit.

Note 3: t_{HAE} is spec'd for case with HLD falling edge occurring at the latest time it can be accepted during the present CPU cycle being executed. If HLD falling edge occurs later, t_{HAE} as long as $(3t_C + 4WS + 72 t_C + 100)$ may occur depending on the following CPU instruction cycles, its wait states and ready input.

Note 4: $WS \times t_{WAIT}$ (number of pre-programmed wait states). Minimum and maximum values are calculated from maximum operating frequency, $t_C = 30$ MHz, with one wait state programmed.

Note 5: Due to emulation restrictions—actual limits will be better.

Note 6: This is guaranteed by design and not tested.

CKI Input Signal Characteristics

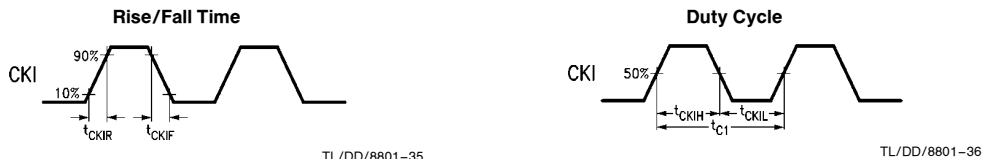

FIGURE 1. CKI Input Signal

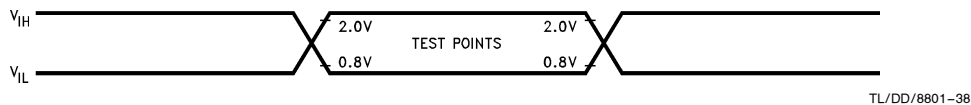

FIGURE 2. Input and Output for AC Tests

Note: AC testing inputs are driven at V_{IH} for a logic "1" and V_{IL} for a logic "0". Output timing measurements are made at 2.0V for a logic "1" and 0.8V for a logic "0".

Timing Waveforms

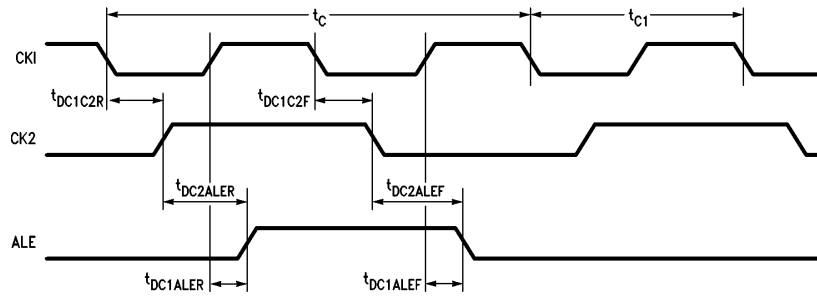

FIGURE 3. CK1, CK2, ALE Timing Diagram

TL/DD/8801-33

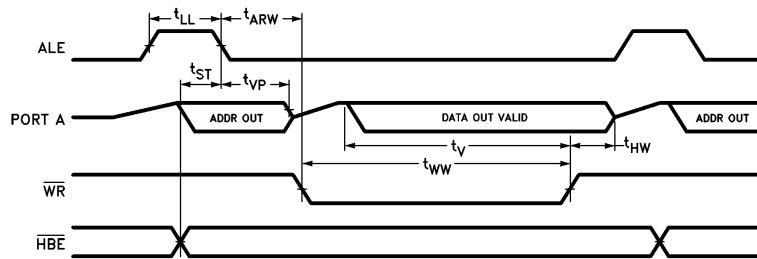

FIGURE 4. Write Cycle

TL/DD/8801-3

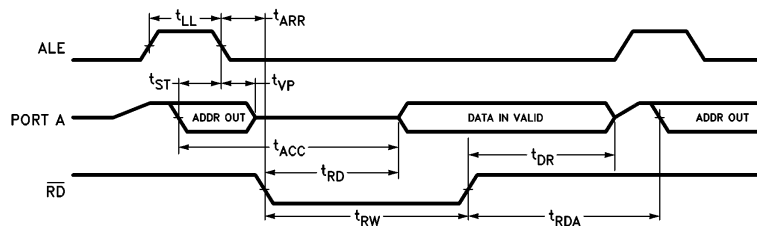

FIGURE 5. Read Cycle

TL/DD/8801-4

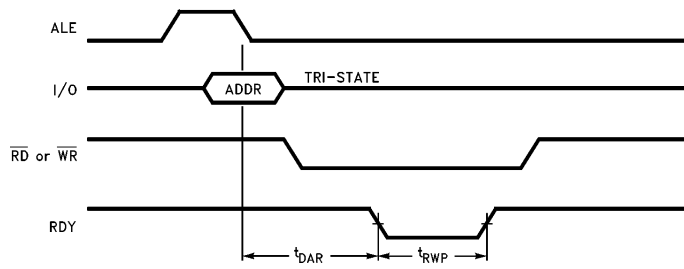

FIGURE 6. Ready Mode Timing

TL/DD/8801-5

Timing Waveforms (Continued)

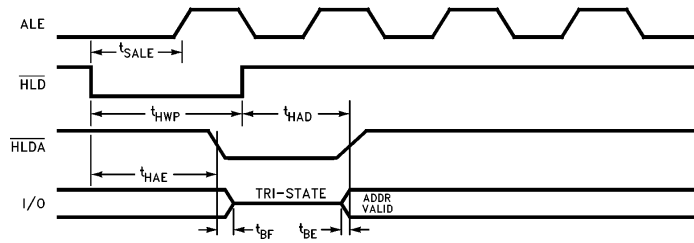

FIGURE 7. Hold Mode Timing

TL/DD/8801-6

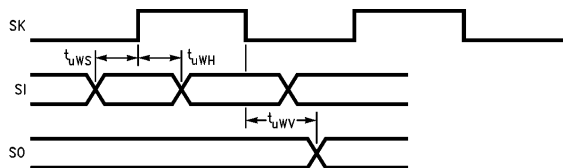

FIGURE 8. MICROWIRE Setup/Hold Timing

TL/DD/8801-37

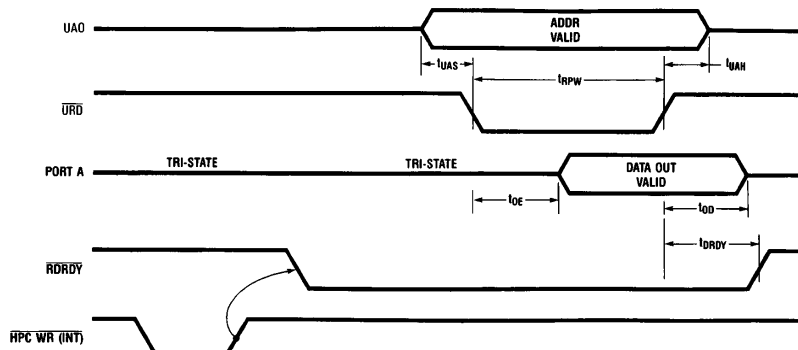

FIGURE 9. UPI Read Timing

TL/DD/8801-9

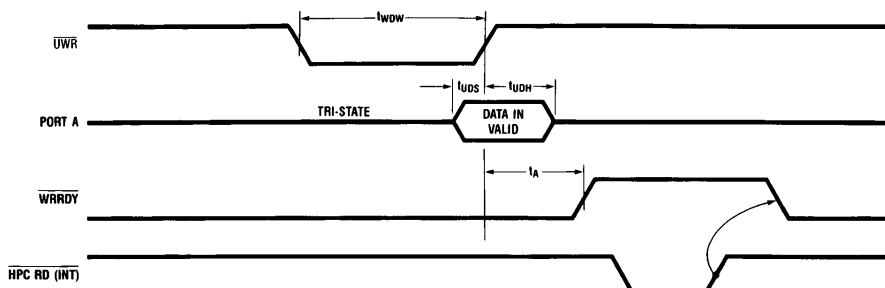

FIGURE 10. UPI Write Timing

TL/DD/8801-10

The following is the Military 883 Electrical Specification for HPC16083 and HPC16003. For latest information on RETS 16083X contact NSC local sales office.

DC Electrical Specifications Test Conditions $V_{CC} = 5V \pm 10\%$ (Unless Otherwise Specified) (Note 1)

Symbol	Parameter	Conditions	SBGRP 1 + 25°C		SBGRP 2 + 125°C		SBGRP 3 - 55°C		Units	Notes
			Min	Max	Min	Max	Min	Max		
V_{IH1}	Logical "1" Input Voltage	RESET, NMI, CKI and \overline{WO}	0.9		0.9		0.9		V	
V_{IH2}		$B_{10}-B_{13}, B_{15}$	(V_{CC})		(V_{CC})		(V_{CC})		V	
V_{IH3}		All Inputs except Port A	0.7		0.7		0.7		V	
		Port A, $V_{CC} = 5.5V$	4.65		4.65		4.65		V	(Note 2)
		Port A, $V_{CC} = 4.5V$	3.95		3.95		3.95		V	(Note 2)
V_{IL1}	Logical "0" Input Voltage	RESET, NMI, CKI and \overline{WO}		0.1		0.1		0.1	V	
V_{IL2}		All Inputs except Port A		(V_{CC})		(V_{CC})		(V_{CC})	V	
V_{IL3}		Port A, $V_{CC} = 5.5V$		0.2		0.2		0.2	V	
		Port A, $V_{CC} = 4.5V$		(V_{CC})		(V_{CC})		(V_{CC})	V	(Note 3)
				0.7		0.7		0.7	V	(Note 3)
				0.5		0.5		0.5	V	(Note 3)
V_{OH2}	Logical "1" Output Voltage	$I_{OH} = -7 \text{ mA}$ ($A_0-A_{15}, B_{10}-B_{12}, B_{15}, CK2$)	2.4		2.4		2.4		V	
V_{OH3}		$I_{OH3} = -1.6 \text{ mA}$ ($B_0-B_9, B_{13}-B_{14}, P_0-P_3$), \overline{WO} (Open Drain)	2.4		2.4		2.4		V	
V_{OH4}		$I_{OH} = -6 \text{ mA}$ (ST1, ST2)	2.4		2.4		2.4		V	
V_{OH5}		$I_{OH} = -1 \text{ mA}$ ($A_0-A_{15}, B_{10}-B_{12}, B_{15}$)	2.4		2.4		2.4		V	
		When Used as an External Address/Data Bus	2.4		2.4		2.4		V	
V_{OL2}	Logical "0" Output Voltage	$I_{OL} = 3 \text{ mA}$ (CK2, $A_0-A_{15}, B_{10}-B_{12}, B_{15}$)		0.4		0.4		0.4	V	
V_{OL3}		$I_{OL} = 0.5 \text{ mA}$ ($B_0-B_9, B_{13}-B_{14}, P_0-P_3$)		0.4		0.4		0.4	V	
		\overline{WO} (Open Drain)		0.4		0.4		0.4	V	
V_{OL4}		$I_{OL} = 1.6 \text{ mA}$ (ST1, ST2)		0.4		0.4		0.4	V	
V_{OL5}		$I_{OL} = 3 \text{ mA}$ ($A_0-A_{15}, B_{10}-B_{12}, B_{15}$)		0.4		0.4		0.4	V	
	When Used as an External Address/Data Bus		0.4		0.4		0.4	V		
I_{OZ}	TRI-STATE Leakage	$V_{SS} \leq V_{IN} \leq V_{CC}$ (\overline{WO} , Port A, Port B), $V_{CC} = 5.5V$		± 5		± 5		± 5	μA	
I_{LI1}	Input Leakage Current	$V_{SS} \leq V_{IN} \leq V_{CC}$, $V_{CC} = 5.5V$ ($I_1-I_6, D_0-D_7, CKI, RESET, EXM, EI$)		± 2		± 2		± 2	μA	(Note 7)
I_{LI2}	Input Pullup Current	$V_{IN} = 0$ ($I_0, I_7, RDY/HLD, EXUI$), $V_{CC} = 5.5V$	-50	-3	-50	-3	-50	-3	μA	(Note 7)
I_{LI3}	Port B_{12} Pulldown during Reset	$V_{IN} = V_{CC}$, Port B_{12} , $V_{CC} = 5.5V$	1	7	1	7	1	7	mA	
VRAM	RAM Keep Alive Voltage	Test Duration is 10 ms	2.5		2.5		2.5		V	
I_{CC1}	Supply Current Dynamic	$F_{IN} = 20 \text{ MHz}$, RESET = V_{SS} , $I_{OH} = 0 \text{ mA}$, $I_{OL} = 0 \text{ mA}$, $V_{CC} = 5.5V$		55		55		55	mA	
I_{CC2}	Idle Mode Current	$F_{IN} = 20 \text{ MHz}$, External Clock		3.5		3.5		3.5	mA	
I_{CC}	Halt Mode Current	NMI = V_{CC}		2		2		2	mA	
CI/O	Input/Output Capacitance	$f_{test} = 1.0 \text{ MHz}$, I/O Pin to Ground		20					pF	(Note 4)
CI	Input Capacitance	$f_{test} = 1.0 \text{ MHz}$, Input Pin to Ground	SBGRP4							
				10					pF	(Note 4)

Note 1: Electrical end point testing (when required) for Groups C & D shall consist only of subgroups 1, 2, 9 and 10.

Note 2: Port A V_{IH} test limit includes 700 mV offset caused by output loads being on during Data Drive Time.

Note 3: Port A V_{IL} test limit includes 400 mV offset caused by output loads being on during Data Drive Time.

Note 4: Verified at initial qual only.

Note 7: Future revisions of this device will not have pullups on pins I_0, I_7 which will be tested to I_{LI1} conditions.

AC Electrical Specifications Test Conditions $V_{CC} = 4.5V$ and $5.5V$ (Unless Otherwise Specified) (Note 1)

Symbol	Parameter	Conditions	SBGRP 9 + 25°C		SBGRP 10 + 125°C		SBGRP 11 - 55°C		Units	Notes
			Min	Max	Min	Max	Min	Max		
$f_C = \text{CKI Freq.}$	Operating Frequency		2	20	2	20	2	20	MHz	(Note 5)
$t_{Cl} = 1/FC$	Clock Period		50		50		50		ns	(Note 5)
$t_C = 2/FC$	Timing Cycle		100		100		100		ns	(Note 5)
$t_{LL} = \frac{1}{2} t_C - 9$	ALE Pulse Width		41		41		41		ns	(Note 6)
$t_{ST} = \frac{1}{4} t_C - 7$	Address Valid to ALE Falling Edge		18		18		18		ns	(Note 6)
$t_{WAIT} = t_C = WS$	Wait State Period		100		100		100		ns	(Note 5)
$FMW = 0.0625 f_C$	External MICROWIRE/PLUS CLK Input Frequency			1.25		1.25		1.25	MHz	(Note 6)
$f_U = 0.125 f_C$	External UART Clock Input Frequency			2.5		2.5		2.5	MHz	(Note 5)
t_{DCIC2}	CK2 Delay From CK1			55		55		55	ns	(Note 6)
$t_{ARR} = \frac{1}{4} t_C - 5$	ALE Falling Edge to \overline{RD} Falling Edge		20		20		20		ns	(Note 6)
$t_{RW} = \frac{1}{2} t_C + WS - 10$	\overline{RD} Pulse Width		140		140		140		ns	(Note 6)
$t_{DR} = 3.4 t_C - 15$	Data Hold after Rising Edge of \overline{RD}		0	60	0	60	0	60	ns	(Note 6)
$t_{RD} = \frac{1}{2} t_C + WS - 65$	\overline{RD} Falling Edge to Data in Valid			85		85		85	ns	(Note 6)
$t_{RDA} = t_C - 15$	\overline{RD} Rising Edge to Address Valid		85		85		85		ns	(Note 6)
$t_{VP} = \frac{1}{4} t_C - 5$	Address Hold from ALE Falling Edge		20		20		20		ns	(Note 6)
$t_{ARW} = \frac{1}{2} t_C - 5$	ALE Trailing Edge to \overline{WR} Falling Edge		45		45		45		ns	(Note 6)
$t_{WW} = \frac{3}{4} t_C + WS - 15$	\overline{WR} Pulse Width		160		160		160		ns	(Note 6)
$t_{HW} = \frac{1}{4} t_C - 5$	Data Hold after Trailing Edge of \overline{WR}		20		20		20		ns	(Note 6)
$t_V = \frac{1}{2} t_C + WS - 5$	Data Valid before Rising Edge of \overline{WR}		145		145		145		ns	(Note 6)
$t_{DAR} = \frac{1}{4} t_C + WS - 50$	Falling Edge of ALE to Falling Edge of \overline{RDY}			75		75		75	ns	(Note 6)

AC Electrical Specifications Test Conditions $V_{CC} = 4.5V$ and $5.5V$ (Unless Otherwise Specified) (Note 1)
(Continued)

Symbol	Parameter	Conditions	SBGRP 9 + 25°C		SBGRP 10 + 125°C		SBGRP 11 - 55°C		Units	Notes
			Min	Max	Min	Max	Min	Max		
$t_{RWP} = t_C$	RDY Pulse Width		100		100		100		ns	(Note 6)
$t_{SALE} = \frac{3}{4} t_C + 40$	Falling Edge of \overline{HLD} to to Rising Edge of ALE		115		115		115		ns	(Note 6)
$t_{HWP} = t_C + 10$	\overline{HLD} Pulse Width		110		110		110		ns	(Note 6)
$t_{HAD} = \frac{3}{4} t_C + 85$	Rising Edge on \overline{HLD} to Rising Edge on \overline{HLDA}			160		160		160	ns	(Note 6)
$t_{HAE} = t_C + 100$	Falling Edge on \overline{HLD} to Falling Edge on \overline{HLDA}			200		200		200	ns	(Note 6)
$t_{BF} = \frac{1}{2} t_C + 66$	BUS Float before Falling Edge on \overline{HLDA}			116		116		116	ns	(Note 6)
$t_{BE} = \frac{1}{2} t_C + 66$	BUS Enable from Rising Edge of \overline{HLDA}		116		116		116		ns	(Note 6)
t_{UAS}	Address Setup Time to Falling Edge of \overline{URD}		10		10		10		ns	(Note 6)
t_{UAH}	Address Hold Time from Rising Edge of \overline{URD}		10		10		10		ns	(Note 6)
t_{RPW}	\overline{URD} Pulse Width		100		100		100		ns	(Note 6)
t_{OE}	\overline{URD} Falling Edge to Data Out Valid			60		60		60	ns	(Note 6)
t_{RDRDY}	\overline{RDY} Delay from Rising Edge of \overline{URD}			70		70		70	ns	(Note 6)
t_{WDW}	\overline{UWR} Pulse Width		40		40		40		ns	(Note 6)
t_{UDS}	Data Invalid before Trailing Edge of \overline{UWR}		10		10		10		ns	(Note 6)
t_{UDH}	Data In Hold after Rising Edge of \overline{UWR}		15		15		15		ns	(Note 6)
t_A	\overline{WRRDY} Delay from Rising Edge of \overline{UWR}			70		70		70	ns	(Note 6)

Note 1: Electrical end point testing (when required) for groups C & D shall consist only of subgroups 1, 2, 9 and 10.

Note 5: Tested in functional patterns. Not directly measured.

Note 6: $C_L = 70$ pF. Input and output levels are per DC characteristics.

Pin Descriptions

The HPC16083 is available in 68-pin PLCC, LDCC, PGA, and 80-pin PQFP packages.

I/O PORTS

Port A is a 16-bit bidirectional I/O port with a data direction register to enable each separate pin to be individually defined as an input or output. When accessing external memory, port A is used as the multiplexed address/data bus.

Port B is a 16-bit port with 12 bits of bidirectional I/O similar in structure to Port A. Pins B10, B11, B12 and B15 are general purpose outputs only in this mode. Port B may also be configured via a 16-bit function register BFUN to individually allow each pin to have an alternate function.

B0:	TDX	UART Data Output
B1:		
B2:	CKX	UART Clock (Input or Output)
B3:	T2IO	Timer2 I/O Pin
B4:	T3IO	Timer3 I/O Pin
B5:	SO	MICROWIRE/PLUS Output
B6:	SK	MICROWIRE/PLUS Clock (Input or Output)
B7:	\overline{HLDA}	Hold Acknowledge Output
B8:	TS0	Timer Synchronous Output
B9:	TS1	Timer Synchronous Output
B10:	UA0	Address 0 Input for UPI Mode
B11:	\overline{WRRDY}	Write Ready Output for UPI Mode
B12:		
B13:	TS2	Timer Synchronous Output

Pin Descriptions (Continued)

B14: TS3 Timer Synchronous Output
 B15: $\overline{\text{RDRDY}}$ Read Ready Output for UPI Mode

When accessing external memory, four bits of port B are used as follows:

B10: ALE Address Latch Enable Output
 B11: $\overline{\text{WR}}$ Write Output
 B12: $\overline{\text{HBE}}$ High Byte Enable Output/Input (sampled at reset)
 B15: $\overline{\text{RD}}$ Read Output

Port I is an 8-bit input port that can be read as general purpose inputs and is also used for the following functions:

I0:
 I1: NMI Nonmaskable Interrupt Input
 I2: INT2 Maskable Interrupt/Input Capture/ $\overline{\text{URD}}$
 I3: INT3 Maskable Interrupt/Input Capture/ $\overline{\text{UWR}}$
 I4: INT4 Maskable Interrupt/Input Capture
 I5: SI MICROWIRE/PLUS Data Input
 I6: RDX UART Data Input
 I7:

Port D is an 8-bit input port that can be used as general purpose digital inputs.

Port P is a 4-bit output port that can be used as general purpose data, or selected to be controlled by timers 4 through 7 in order to generate frequency, duty cycle and pulse width modulated outputs.

POWER SUPPLY PINS

V_{CC1} and

V_{CC2} Positive Power Supply

GND Ground for On-Chip Logic

DGND Ground for Output Buffers

Note: There are two electrically connected V_{CC} pins on the chip, GND and DGND are electrically isolated. Both V_{CC} pins and both ground pins must be used.

CLOCK PINS

CKI The Chip System Clock Input

CKO The Chip System Clock Output (inversion of CKI)

Pins CKI and CKO are usually connected across an external crystal.

CK2 Clock Output (CKI divided by 2)

OTHER PINS

$\overline{\text{WO}}$ This is an active low open drain output that signals an illegal situation has been detected by the Watch Dog logic.

ST1 Bus Cycle Status Output: indicates first opcode fetch.

ST2 Bus Cycle Status Output: indicates machine states (skip, interrupt and first instruction cycle).

$\overline{\text{RESET}}$ is an active low input that forces the chip to restart and sets the ports in a TRI-STATE mode.

$\text{RDY}/\overline{\text{HLD}}$ has two uses, selected by a software bit. It's either a READY input to extend the bus cycle for slower memories, or a HOLD request input to put the bus in a high impedance state for DMA purposes.

NC (no connection) do not connect anything to this pin.

EXM External memory enable (active high) disables internal ROM and maps it to external memory.

EI External interrupt with vector address FFF1:FFF0. (Rising/falling edge or high/low level sensitive). Alternately can be configured as 4th input capture.

$\overline{\text{EXUI}}$ External interrupt which is internally OR'ed with the UART interrupt with vector address FFF3:FFF2 (Active Low).

Connection Diagrams

Plastic and Ceramic Leaded Chip Carriers

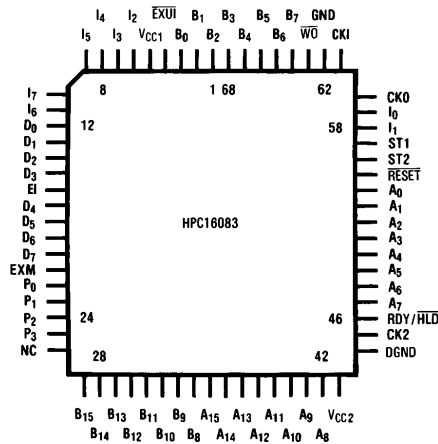

TL/DD/8801-11

Top View

See NS Package Number EL68A or V68A

See Part Selection for Ordering Information

Connection Diagrams (Continued)

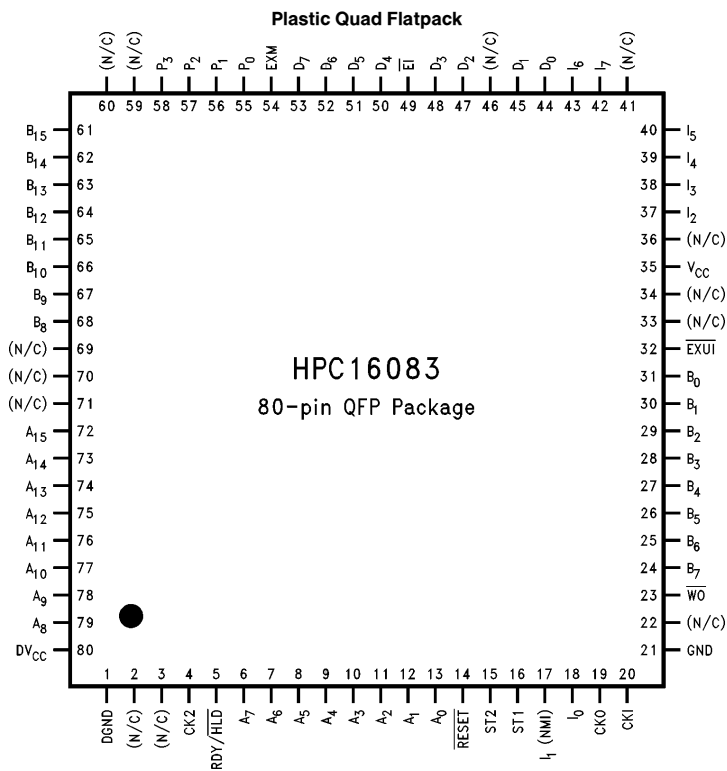

Top View

See NS Package Number VJE80A
See Part Selection for Ordering Information

Pin Grid Array Pinout

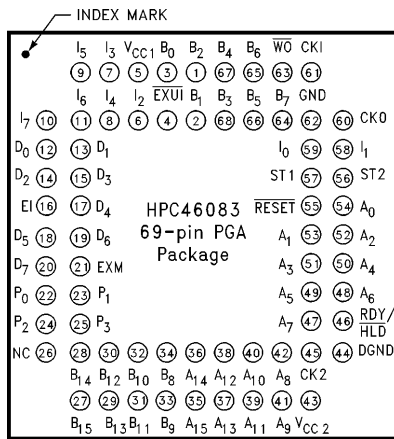

Top View

(looking down on component side of PC Board)

See NS Package Number U68A
See Part Selection for Ordering Information

Ports A & B

The highly flexible A and B ports are similarly structured. The Port A (see *Figure 11*), consists of a data register and a direction register. Port B (see *Figures 12, 13, 14*) has an alternate function register in addition to the data and direction registers. All the control registers are read/write registers.

The associated direction registers allow the port pins to be individually programmed as inputs or outputs. Port pins selected as inputs, are placed in a TRI-STATE mode by resetting corresponding bits in the direction register.

A write operation to a port pin configured as an input causes the value to be written into the data register, a read operation returns the value of the pin. Writing to port pins configured as outputs causes the pins to have the same value, reading the pins returns the value of the data register.

Primary and secondary functions are multiplexed onto Port B through the alternate function register (BFUN). The secondary functions are enabled by setting the corresponding bits in the BFUN register.

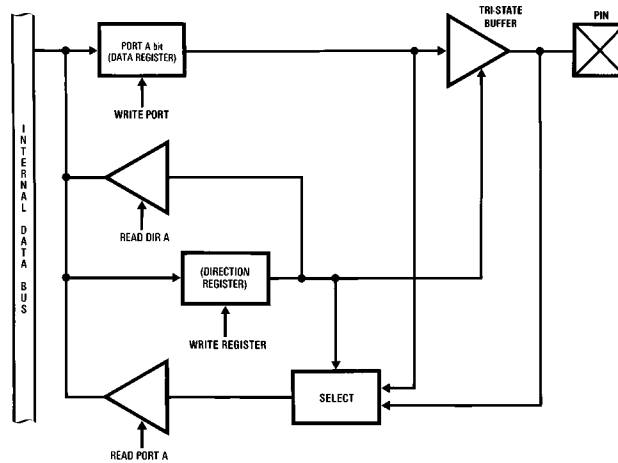

TL/DD/8801-13

FIGURE 11. Port A: I/O Structure

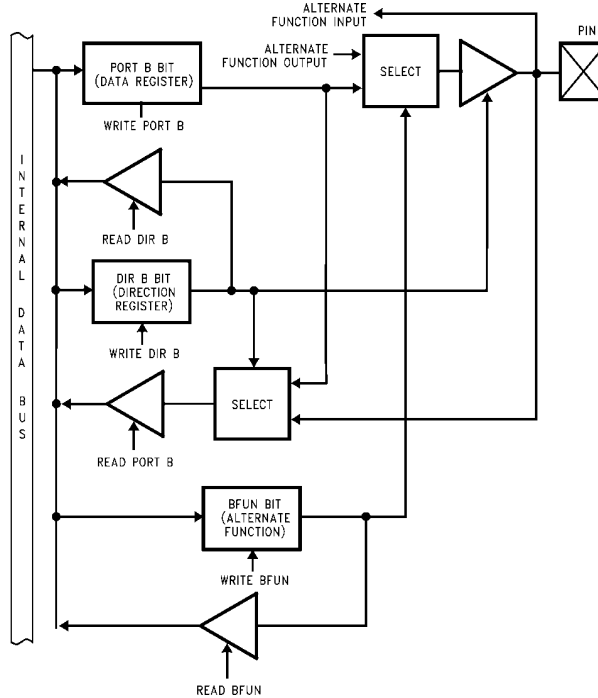

TL/DD/8801-14

FIGURE 12. Structure of Port B Pins B0, B1, B2, B5, B6 and B7 (Typical Pins)

Ports A & B (Continued)

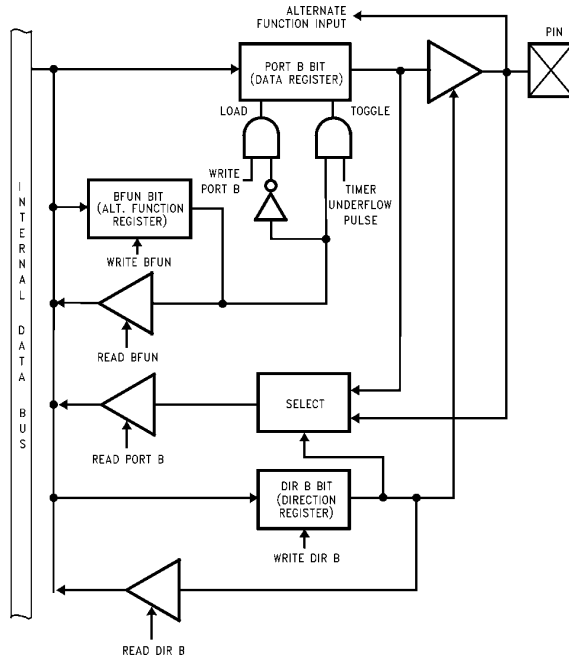

TL/DD/8801-15

FIGURE 13. Structure of Port B Pins B3, B4, B8, B9, B13 and B14 (Timer Synchronous Pins)

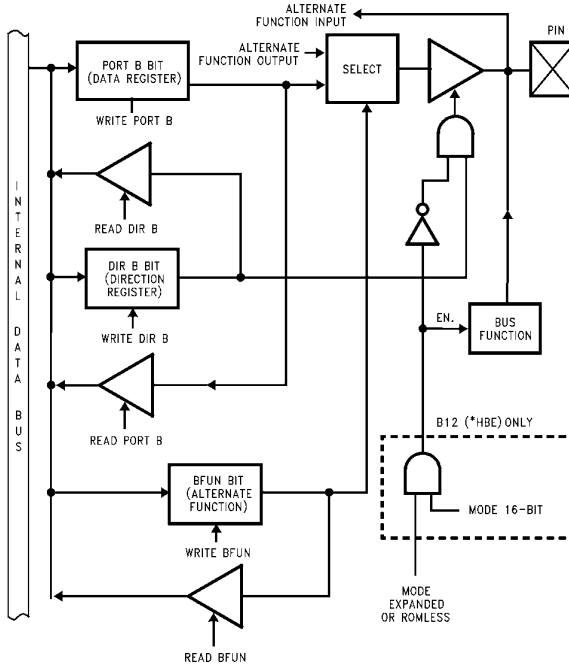

TL/DD/8801-16

FIGURE 14. Structure of Port B Pins B10, B11, B12 and B15 (Pins with Bus Control Roles)

Operating Modes

To offer the user a variety of I/O and expanded memory options, the HPC16083 has four operating modes. The ROMless HPC16003 has one mode of operation. The various modes of operation are determined by the state of both the EXM pin and the EA bit in the PSW register. The state of the EXM pin determines whether on-chip ROM will be accessed or external memory will be accessed within the address range of the on-chip ROM. The on-chip ROM range of the HPC16083 is E000 to FFFF (8k bytes). The HPC16003 has no on-chip ROM and is intended for use with external memory for program storage. A logic “0” state on the EXM pin will cause the HPC device to address on-chip ROM when the Program Counter (PC) contains addresses within the on-chip ROM address range. A logic “1” state on the EXM pin will cause the HPC device to address memory that is external to the HPC when the PC contains on-chip ROM addresses. The EXM pin should always be pulled high (logic “1”) on the HPC16003 because no on-chip ROM is available. The function of the EA bit is to determine the legal addressing range of the HPC device. A logic “0” state in the EA bit of the PSW register does two things—addresses are limited to the on-chip ROM range and on-chip RAM and Register range, and the “illegal address detection” feature of the WATCHDOG logic is engaged. A logic “1” in the EA bit enables accesses to be made anywhere within the 64k byte address range and the “illegal address detection” feature of the WATCHDOG logic is disabled. The EA bit should be set to “1” by software when using the HPC16003 to disable the “illegal address detection” feature of WATCHDOG.

All HPC devices can be used with external memory. External memory may be any combination of RAM and ROM. Both 8-bit and 16-bit external data bus modes are available. Upon entering an operating mode in which external memory is used, port A becomes the Address/Data bus. Four pins of port B become the control lines ALE, \overline{RD} , \overline{WR} and \overline{HBE} . The High Byte Enable pin (\overline{HBE}) is used in 16-bit mode to select high order memory bytes. The \overline{RD} and \overline{WR} signals are only generated if the selected address is off-chip. The 8-bit mode is selected by pulling \overline{HBE} high at reset. If \overline{HBE} is left floating or connected to a memory device chip select at reset, the 16-bit mode is entered. The following sections describe the operating modes of the HPC16083 and HPC16003.

Note: The HPC devices use 16-bit words for stack memory. Therefore, when using the 8-bit mode, User’s Stack must be in internal RAM.

HPC16083 Operating Modes

SINGLE CHIP NORMAL MODE

In this mode, the HPC16083 functions as a self-contained microcomputer (see *Figure 15*) with all memory (RAM and

ROM) on-chip. It can address internal memory only, consisting of 8k bytes of ROM (E000 to FFFF) and 256 bytes of on-chip RAM and registers (0000 to 01FF). The “illegal address detection” feature of the WATCHDOG is enabled in the Single-Chip Normal mode and a WATCHDOG Output (WO) will occur if an attempt is made to access addresses that are outside of the on-chip ROM and RAM range of the device. Ports A and B are used for I/O functions and not for addressing external memory. The EXM pin and the EA bit of the PSW register must both be logic “0” to enter the Single-Chip Normal mode.

EXPANDED NORMAL MODE

The Expanded Normal mode of operation enables the HPC16083 to address external memory in addition to the on-chip ROM and RAM (see Table I). WATCHDOG illegal address detection is disabled and memory accesses may be made anywhere in the 64k byte address range without triggering an illegal address condition. The Expanded Normal mode is entered with the EXM pin pulled low (logic “0”) and setting the EA bit in the PSW register to “1”.

SINGLE-CHIP ROMLESS MODE

In this mode, the on-chip mask programmed ROM of the HPC16083 is not used. The address space corresponding to the on-chip ROM is mapped into external memory so 8k bytes of external memory may be used with the HPC16083 (see Table I). The WATCHDOG circuitry detects illegal addresses (addresses not within the on-chip ROM and RAM range). The Single-Chip ROMless mode is entered when the EXM pin is pulled high (logic “1”) and the EA bit is logic “0”.

EXPANDED ROMLESS MODE

This mode of operation is similar to Single-Chip ROMless mode in that no on-chip ROM is used, however, a full 64k bytes of external memory may be used. The “illegal address detection” feature of WATCHDOG is disabled. The EXM pin must be pulled high (logic “1”) and the EA bit in the PSW register set to “1” to enter this mode.

TABLE I. HPC16083 Operating Modes

Operating Mode	EXM Pin	EA Bit	Memory Configuration
Single-Chip Normal	0	0	E000:FFFF on-chip
Expanded Normal	0	1	E000:FFFF on-chip 0200:FFFF off-chip
Single-Chip ROMless	1	0	E000:FFFF off-chip
Expanded ROMless	1	1	0200:FFFF off-chip

Note: In all operating modes, the on-chip RAM and Registers (0000:01FF) may be accessed.

HPC16003 Operating Modes

EXPANDED ROMLESS MODE (HPC16003)

Because the HPC16003 has no on-chip ROM, it has only one mode of operation, the Expanded ROMless Mode. The EXM pin must be pulled high (logic "1") on power up, the EA bit in the PSW register should be set to a "1". The HPC16003 is a ROMless device and is intended for use with external memory. The external memory may be any combination of ROM and RAM. Up to 64k bytes of external memory may be accessed. It is necessary to vector on reset to an address between F000 and FFFF, therefore the user should have external memory at these addresses. The EA bit in the PSW register must immediately be set to "1" at the beginning of the user's program to disable illegal address detection in the WATCHDOG logic.

TABLE II. HPC16003 Operating Modes

Operating Mode	EXM Pin	EA Bit	Memory Configuration
Expanded ROMless	1	1	0200:FFFF off-chip

Note: The on-chip RAM and Registers (0000:01FF) of the HPC16003 may be accessed at all times.

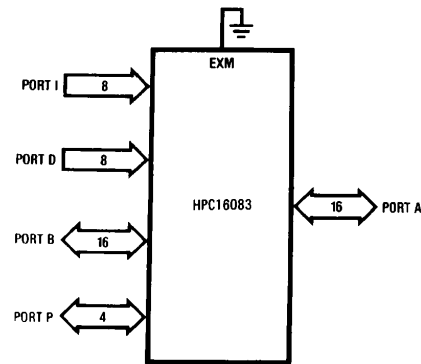

TL/DD/8801-17

FIGURE 15. Single-Chip Mode

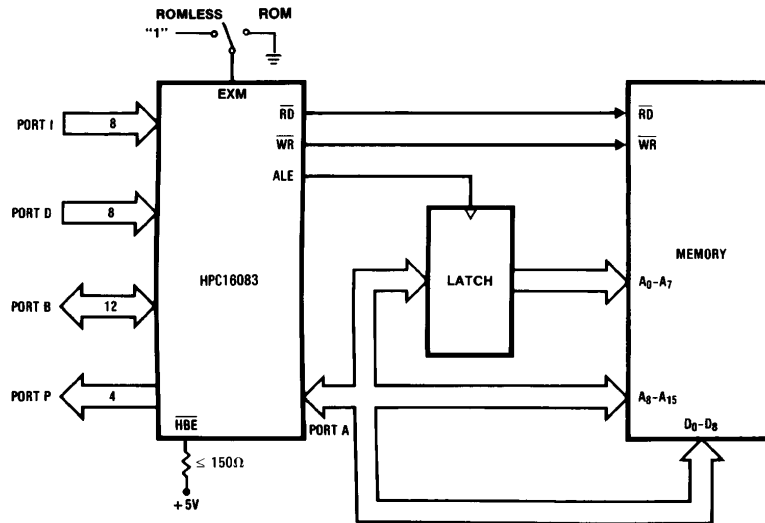

TL/DD/8801-18

FIGURE 16. 8-Bit External Memory

HPC16003 Operating Modes (Continued)

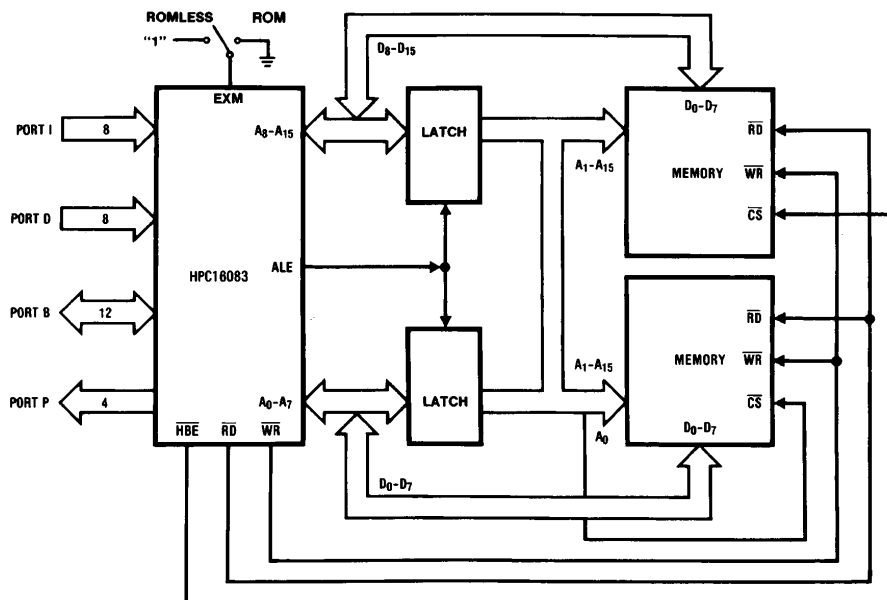

FIGURE 17. 16-Bit External Memory

TL/DD/8801-19

Wait States

The internal ROM can be accessed at the maximum operating frequency with one wait state. With 0 wait states, internal ROM accesses are limited to $\frac{2}{3} f_C$ max.

The HPC16083 provides four software selectable Wait States that allow access to slower memories. The Wait States are selected by the state of two bits in the PSW register. Additionally, the RDY input may be used to extend the instruction cycle, allowing the user to interface with slow memories and peripherals.

Power Save Modes

Two power saving modes are available on the HPC16083: HALT and IDLE. In the HALT mode, all processor activities are stopped. In the IDLE mode, the on-board oscillator and timer T0 are active but all other processor activities are stopped. In either mode, all on-board RAM, registers and I/O are unaffected.

HALT MODE

The HPC16083 is placed in the HALT mode under software control by setting bits in the PSW. All processor activities, including the clock and timers, are stopped. In the HALT mode, power requirements for the HPC16083 are minimal and the applied voltage (V_{CC}) may be decreased without altering the state of the machine. There are two ways of exiting the HALT mode: via the $\overline{\text{RESET}}$ or the NMI. The $\overline{\text{RESET}}$ input reinitializes the processor. Use of the NMI input will generate a vectored interrupt and resume operation from that point with no initialization. The HALT mode can be enabled or disabled by means of a control register HALT enable. To prevent accidental use of the HALT mode the HALT enable register can be modified only once.

IDLE MODE

The HPC16083 is placed in the IDLE mode through the PSW. In this mode, all processor activity, except the on-board oscillator and Timer T0, is stopped. As with the HALT mode, the processor is returned to full operation by the $\overline{\text{RESET}}$ or NMI inputs, but without waiting for oscillator stabilization. A timer T0 overflow will also cause the HPC16083 to resume normal operation.

HPC16083 Interrupts

Complex interrupt handling is easily accomplished by the HPC16083's vectored interrupt scheme. There are eight possible interrupt sources as shown in Table III.

TABLE III. Interrupts

Vector Address	Interrupt Source	Arbitration Ranking
FFFF:FFFE	$\overline{\text{RESET}}$	0
FFFD:FFFC	Nonmaskable external on rising edge of I1 pin	1
FFFB:FFFA	External interrupt on I2 pin	2
FFF9:FFF8	External interrupt on I3 pin	3
FFF7:FFF6	External interrupt on I4 pin	4
FFF5:FFF4	Overflow on internal timers	5
FFF3:FFF2	Internal on the UART transmit/receive complete or external on EXUI	6
FFF1:FFF0	External interrupt on EI pin	7

Interrupt Arbitration

The HPC16083 contains arbitration logic to determine which interrupt will be serviced first if two or more interrupts occur simultaneously. The arbitration ranking is given in Table III. The interrupt on $\overline{\text{RESET}}$ has the highest rank and is serviced first.

Interrupt Processing

Interrupts are serviced after the current instruction is completed except for the $\overline{\text{RESET}}$, which is serviced immediately. $\overline{\text{RESET}}$ and EXUI are level-LOW-sensitive interrupts and EI is programmable for edge-(RISING or FALLING) or level-(HIGH or LOW) sensitivity. All other interrupts are edge-sensitive. NMI is positive-edge sensitive. The external interrupts on I2, I3 and I4 can be software selected to be rising or falling edge. External interrupt (EXUI) is shared with the UART interrupt. This interrupt is level-low sensitive. To select this interrupt disable the ERI and ETI UART interrupt bits in the ENUI register. To select the UART interrupt leave this pin floating or tie it high.

Interrupt Control Registers

The HPC16083 allows the various interrupt sources and conditions to be programmed. This is done through the various control registers. A brief description of the different control registers is given below.

INTERRUPT ENABLE REGISTER (ENIR)

$\overline{\text{RESET}}$ and the External Interrupt on I1 are non-maskable interrupts. The other interrupts can be individually enabled or disabled. Additionally, a Global Interrupt Enable Bit in the ENIR Register allows the Maskable interrupts to be collectively enabled or disabled. Thus, in order for a particular interrupt to request service both the individual enable bit and the Global Interrupt bit (GIE) have to be set.

INTERRUPT PENDING REGISTER (IRPD)

The IRPD register contains a bit allocated for each interrupt vector. The occurrence of specified interrupt trigger conditions causes the appropriate bit to be set. There is no indication of the order in which the interrupts have been received. The bits are set independently of the fact that the

interrupts may be disabled. IRPD is a Read/Write register. The bits corresponding to the maskable, external interrupts are normally cleared by the HPC16083 after servicing the interrupts.

For the interrupts from the on-board peripherals, the user has the responsibility of resetting the interrupt pending flags through software.

The NMI bit is read only and I2, I3, and I4 are designed as to only allow a zero to be written to the pending bit (writing a one has no effect). A LOAD IMMEDIATE instruction is to be the only instruction used to clear a bit or bits in the IRPD register. This allows a mask to be used, thus ensuring that the other pending bits are not affected.

INTERRUPT CONDITION REGISTER (IRCD)

Three bits of the register select the input polarity of the external interrupt on I2, I3, and I4.

Servicing the Interrupts

The Interrupt, once acknowledged, pushes the program counter (PC) onto the stack thus incrementing the stack pointer (SP) twice. The Global Interrupt Enable bit (GIE) is copied into the CGIE bit of the PSW register; it is then reset, thus disabling further interrupts. The program counter is loaded with the contents of the memory at the vector address and the processor resumes operation at this point. At the end of the interrupt service routine, the user does a RETI instruction to pop the stack and re-enable interrupts if the CGIE bit is set, or RET to just pop the stack if the CGIE bit is clear, and then returns to the main program. The GIE bit can be set in the interrupt service routine to nest interrupts if desired. *Figure 18* shows the Interrupt Enable Logic.

$\overline{\text{RESET}}$

The $\overline{\text{RESET}}$ input initializes the processor and sets ports A and B in the TRI-STATE condition and port P in the LOW state. $\overline{\text{RESET}}$ is an active-low Schmitt trigger input. The processor vectors to FFFF:FFFE and resumes operation at the address contained at that memory location (which must correspond to an on board location). The Reset vector address must be between E000 and FFFF when using the HPC16003.

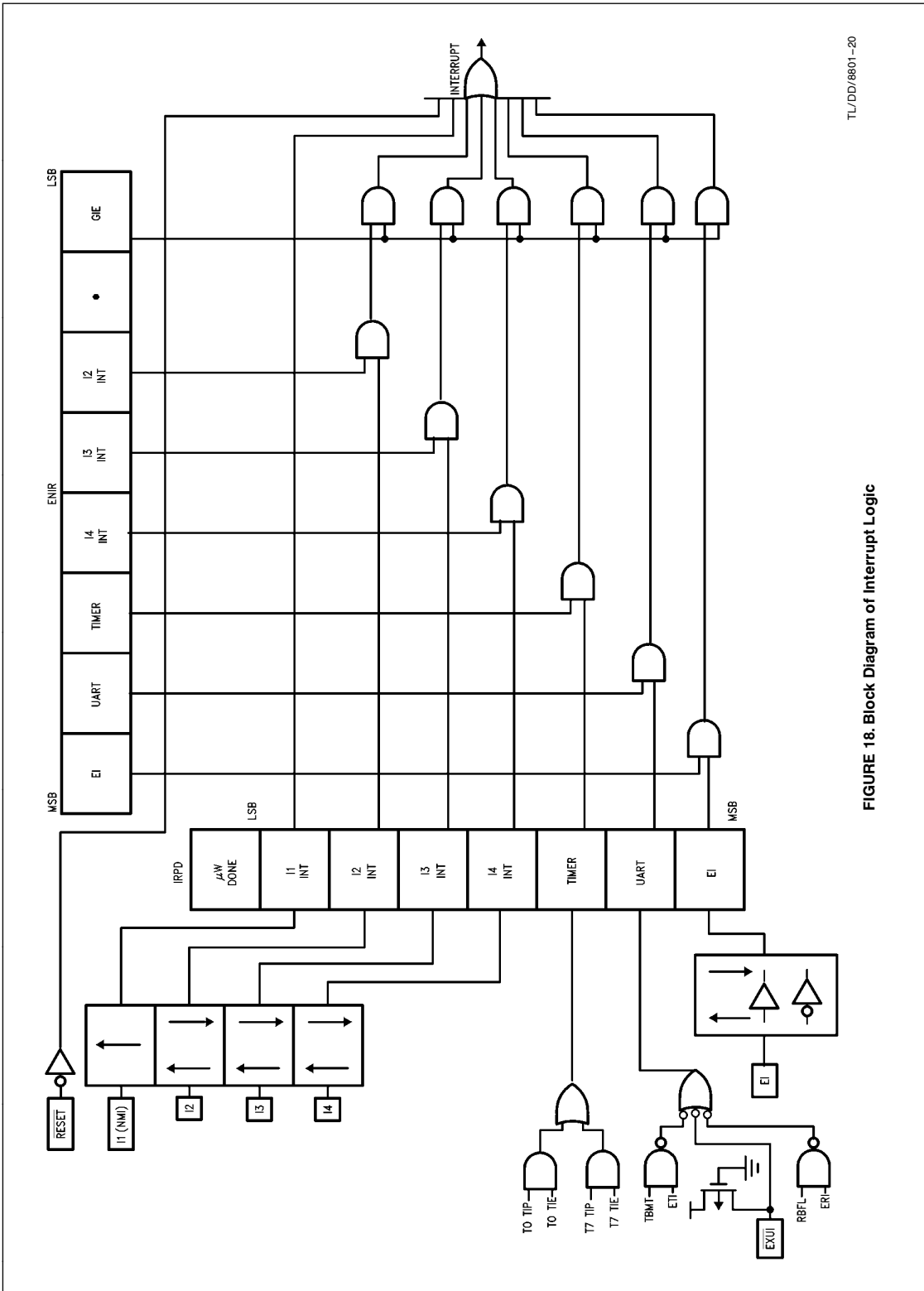

TL/DD/8801-20

FIGURE 18. Block Diagram of Interrupt Logic

Timer Overview

The HPC16083 contains a powerful set of flexible timers enabling the HPC16083 to perform extensive timer functions; not usually associated with microcontrollers.

The HPC16083 contains nine 16-bit timers. Timer T0 is a free-running timer, counting up at a fixed CKI/16 (Clock Input/16) rate. It is used for WATCHDOG logic, high speed event capture, and to exit from the IDLE mode. Consequently, it cannot be stopped or written to under software control. Timer T0 permits precise measurements by means of the capture registers I2CR, I3CR, and I4CR. A control bit in the register TMMODE configures timer T1 and its associated register R1 as capture registers I3CR and I2CR. The capture registers I2CR, I3CR, and I4CR respectively, record the value of timer T0 when specific events occur on the interrupt pins I2, I3, and I4. The control register IRCD programs the capture registers to trigger on either a rising edge or a falling edge of its respective input. The specified edge can also be programmed to generate an interrupt (see Figure 19).

The HPC16083 provides an additional 16-bit free running timer, T8, with associated input capture register EICR (External Interrupt Capture Register) and Configuration Register, EICON. EICON is used to select the mode and edge of the EI pin. EICR is a 16-bit capture register which records the value of T8 (which is identical to T0) when a specific event occurs on the EI pin.

The timers T2 and T3 have selectable clock rates. The clock input to these two timers may be selected from the following two sources: an external pin, or derived internally by dividing the clock input. Timer T2 has additional capability of being clocked by the timer T3 underflow. This allows the user to cascade timers T3 and T2 into a 32-bit timer/counter. The control register DIVBY programs the clock input to timers T2 and T3 (see Figure 20).

The timers T1 through T7 in conjunction with their registers form Timer-Register pairs. The registers hold the pulse duration values. All the Timer-Register pairs can be read from or written to. Each timer can be started or stopped under

software control. Once enabled, the timers count down, and upon underflow, the contents of its associated register are automatically loaded into the timer.

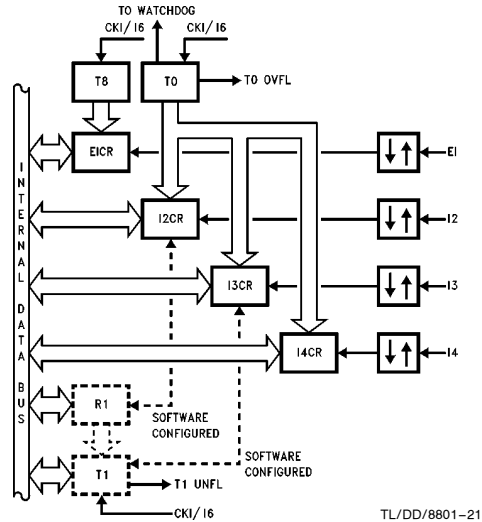

FIGURE 19. Timers T0, T1 and T8 with Four Input Capture Registers

SYNCHRONOUS OUTPUTS

The flexible timer structure of the HPC16083 simplifies pulse generation and measurement. There are four synchronous timer outputs (TS0 through TS3) that work in conjunction with the timer T2. The synchronous timer outputs can be used either as regular outputs or individually programmed to toggle on timer T2 underflows (see Figure 20).

Timer/register pairs 4-7 form four identical units which can generate synchronous outputs on port P (see Figure 21).

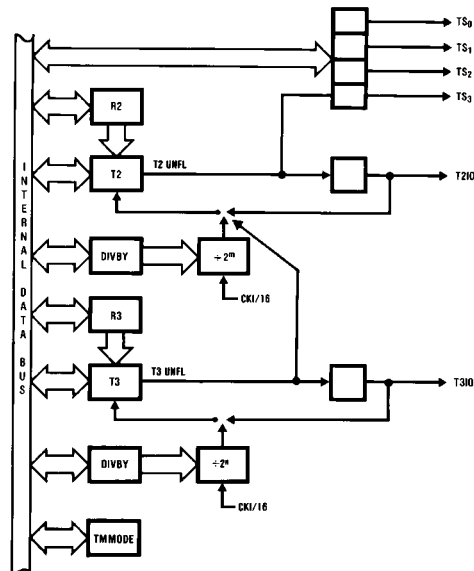
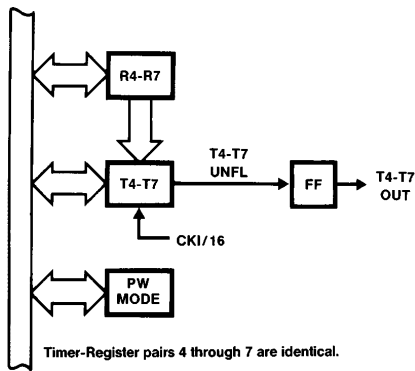

FIGURE 20. Timers T2-T3 Block

Timer Overview (Continued)



TL/DD/8801-23

FIGURE 21. Timers T4-T7 Block

Maximum output frequency for any timer output can be obtained by setting timer/register pair to zero. This then will produce an output frequency equal to $\frac{1}{2}$ the frequency of the source used for clocking the timer.

Timer Registers

There are four control registers that program the timers. The divide by (DIVBY) register programs the clock input to timers T2 and T3. The timer mode register (TMMODE) contains control bits to start and stop timers T1 through T3. It also contains bits to latch, acknowledge and enable interrupts from timers T0 through T3. The control register PWMODE similarly programs the pulse width timers T4 through T7 by allowing them to be started, stopped, and to latch and enable interrupts on underflows. The PORTP register contains bits to preset the outputs and enable the synchronous timer output functions.

Timer Applications

The use of Pulse Width Timers for the generation of various waveforms is easily accomplished by the HPC160B3.

Frequencies can be generated by using the timer/register pairs. A square wave is generated when the register value is a constant. The duty cycle can be controlled simply by changing the register value.



TL/DD/8801-24

FIGURE 22. Square Wave Frequency Generation

Synchronous outputs based on Timer T2 can be generated on the 4 outputs TS0-TS3. Each output can be individually programmed to toggle on T2 underflow. Register R2 contains the time delay between events. Figure 23 is an example of synchronous pulse train generation.

WATCHDOG Logic

The WATCHDOG Logic monitors the operations taking place and signals upon the occurrence of any illegal activity. The illegal conditions that trigger the WATCHDOG logic are potentially infinite loops and illegal addresses. Should the

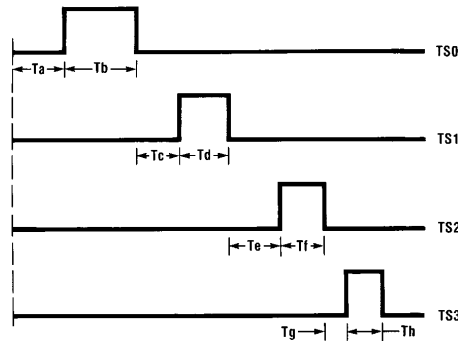

TL/DD/8801-25

FIGURE 23. Synchronous Pulse Generation

WATCHDOG register not be written to before Timer T0 overflows twice, or more often than once every 4096 counts, an infinite loop condition is assumed to have occurred. An illegal condition also occurs when the processor generates an illegal address when in the Single-Chip modes.* Any illegal condition forces the WATCHDOG Output (WO) pin low. The WO pin is an open drain output and can be connected to the RESET or NMI inputs or to the users external logic.

*Note: See Operating Modes for details.

MICROWIRE/PLUS

MICROWIRE/PLUS is used for synchronous serial data communications (see Figure 24). MICROWIRE/PLUS has an 8-bit parallel-loaded, serial shift register using SI as the input and SO as the output. SK is the clock for the serial shift register (SIO). The SK clock signal can be provided by an internal or external source. The internal clock rate is programmable by the DIVBY register. A DONE flag indicates when the data shift is completed.

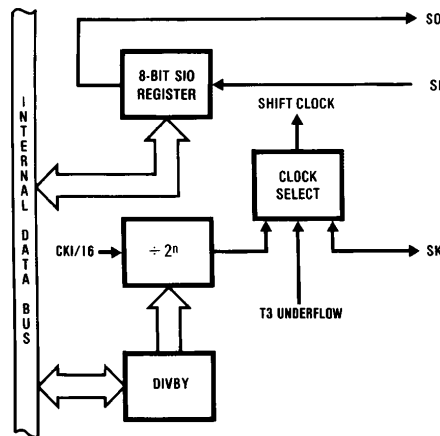

TL/DD/8801-26

FIGURE 24. MICROWIRE/PLUS

The MICROWIRE/PLUS capability enables it to interface with any of National Semiconductor's MICROWIRE peripherals (i.e., A/D converters, display drivers, EEPROMs).

HPC16083 UART

The HPC16083 contains a software programmable UART. The UART (see *Figure 26*) consists of a transmit shift register, a receiver shift register and five addressable registers, as follows: a transmit buffer register (TBUF), a receiver buffer register (RBUF), a UART control and status register (ENU), a UART receive control and status register (ENUR) and a UART interrupt and clock source register (ENUI). The ENU register contains flags for transmit and receive functions; this register also determines the length of the data frame (8 or 9 bits) and the value of the ninth bit in transmission. The ENUR register flags framing and data overrun errors while the UART is receiving. Other functions of the ENUR register include saving the ninth bit received in the data frame and enabling or disabling the UART's Wake-up Mode of operation. The determination of an internal or external clock source is done by the ENUI register, as well as selecting the number of stop bits and enabling or disabling transmit and receive interrupts.

The baud rate clock for the Receiver and Transmitter can be selected for either an internal or external source using two bits in the ENUI register. The internal baud rate is programmed by the DIVBY register. The baud rate may be selected from a range of 8 Hz to 128 kHz in binary steps or T3 underflow. By selecting a 9.83 MHz crystal, all standard baud rates from 75 baud to 38.4 kBaund can be generated. The external baud clock source comes from the CKX pin. The Transmitter and Receiver can be run at different rates by selecting one to operate from the internal clock and the other from an external source.

The HPC16083 UART supports two data formats. The first format for data transmission consists of one start bit, eight data bits and one or two stop bits. The second data format for transmission consists of one start bit, nine data bits, and one or two stop bits. Receiving formats differ from transmission only in that the Receiver always requires only one stop bit in a data frame.

UART Wake-up Mode

The HPC16083 UART features a Wake-up Mode of operation. This mode of operation enables the HPC16083 to be networked with other processors. Typically in such environments, the messages consist of addresses and actual data. Addresses are specified by having the ninth bit in the data frame set to 1. Data in the message is specified by having the ninth bit in the data frame reset to 0.

The UART monitors the communication stream looking for addresses. When the data word with the ninth bit set is received, the UART signals the HPC16083 with an interrupt. The processor then examines the content of the receiver buffer to decide whether it has been addressed and whether to accept subsequent data.

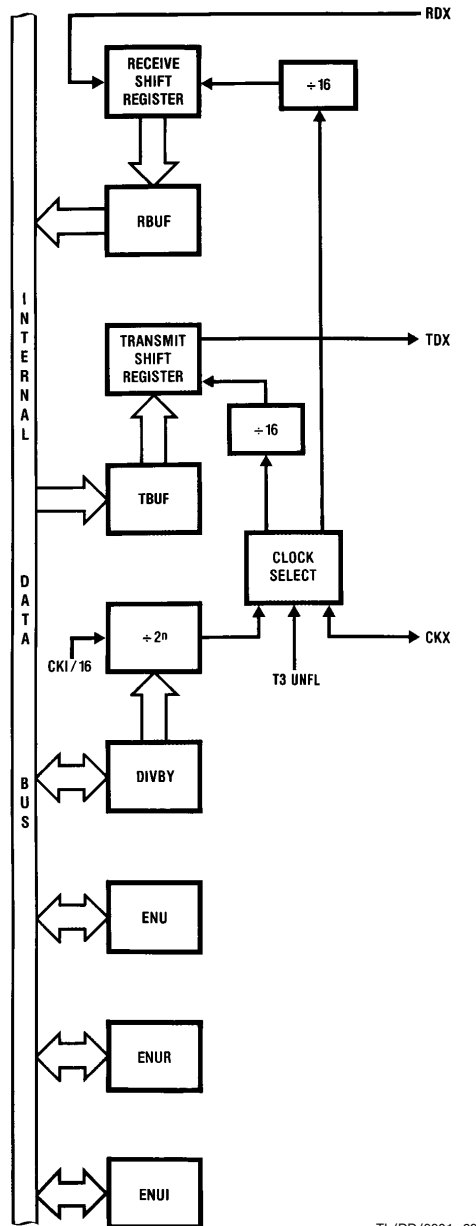

FIGURE 26. UART Block Diagram

TL/DD/8801-28

Universal Peripheral Interface

The Universal Peripheral Interface (UPI) allows the HPC16083 to be used as an intelligent peripheral to another processor. The UPI could thus be used to tightly link two HPC16083's and set up systems with very high data exchange rates. Another area of application could be where a HPC16083 is programmed as an intelligent peripheral to a host system such as the Series 32000® microprocessor. *Figure 27* illustrates how a HPC16083 could be used as an intelligent peripheral for a Series 32000-based application.

The interface consists of a Data Bus (port A), a Read Strobe (\overline{URD}), a Write Strobe (\overline{UWR}), a Read Ready Line (\overline{RDRDY}), a Write Ready Line (\overline{WRRDY}) and one Address Input (UA0). The data bus can be either eight or sixteen bits wide.

The \overline{URD} and \overline{UWR} inputs may be used to interrupt the HPC16083. The \overline{RDRDY} and \overline{WRRDY} outputs may be used to interrupt the host processor.

The UPI contains an Input Buffer (IBUF), an Output Buffer (OBUF) and a Control Register (UPIC). In the UPI mode, port A on the HPC16083 is the data bus. UPI can only be used if the HPC16083 is in the Single-Chip mode.

Shared Memory Support

Shared memory access provides a rapid technique to exchange data. It is effective when data is moved from a peripheral to memory or when data is moved between blocks of memory. A related area where shared memory access proves effective is in multiprocessing applications where two CPUs share a common memory block. The HPC16083 supports shared memory access with two pins. The pins are the RDY/HLD input pin and the HLD/A output pin. The user can software select either the Hold or Ready function by the state of a control bit. The HLD/A output is multiplexed onto port B.

The host uses DMA to interface with the HPC16083. The host initiates a data transfer by activating the \overline{HLD} input of the HPC16083. In response, the HPC16083 places its system bus in a TRI-STATE Mode, freeing it for use by the host. The host waits for the acknowledge signal (\overline{HLDA}) from the HPC16083 indicating that the system bus is free. On receiving the acknowledge, the host can rapidly transfer data into, or out of, the shared memory by using a conventional DMA controller. Upon completion of the message transfer, the host removes the HOLD request and the HPC16083 resumes normal operations.

Figure 28 illustrates an application of the shared memory interface between the HPC16083 and a Series 32000 system. To insure proper operation, the interface logic shown is recommended as the means for enabling and disabling the user's bus.

Memory

The HPC16083 has been designed to offer flexibility in memory usage. A total address space of 64 kbytes can be addressed with 8 kbytes of ROM and 256 bytes of RAM available on the chip itself. The ROM may contain program instructions, constants or data. The ROM and RAM share the same address space allowing instructions to be executed out of RAM.

Program memory addressing is accomplished by the 16-bit program counter on a byte basis. Memory can be addressed directly by instructions or indirectly through the B, X and SP registers. Memory can be addressed as words or bytes. Words are always addressed on even-byte boundaries. The HPC16083 uses memory-mapped organization to support registers, I/O and on-chip peripheral functions.

The HPC16083 memory address space extends to 64 kbytes and registers and I/O are mapped as shown in Table IV.

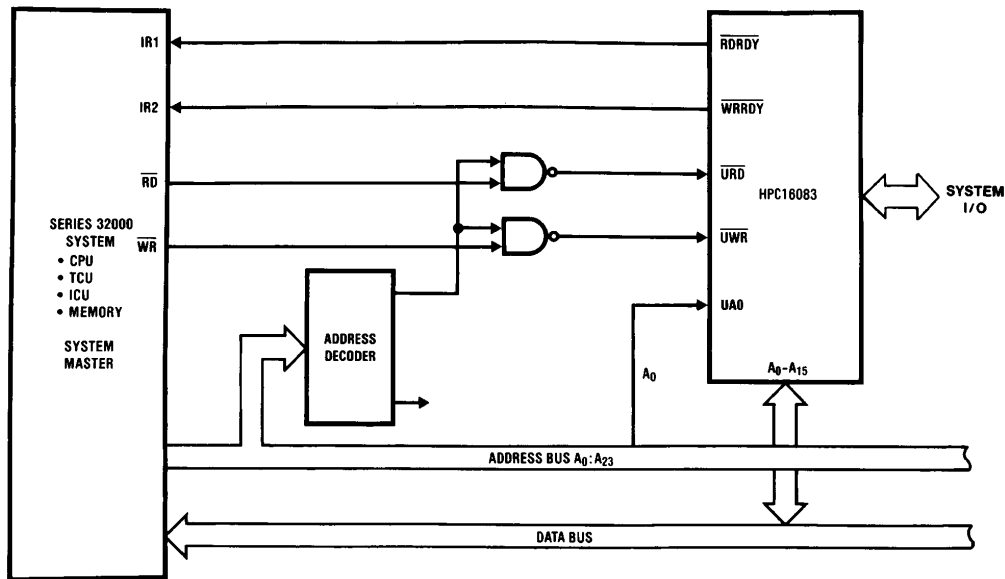

FIGURE 27. HPC16083 as a Peripheral: (UPI Interface to Series 32000 Application)

TL/DD/8801-29

Shared Memory Support (Continued)

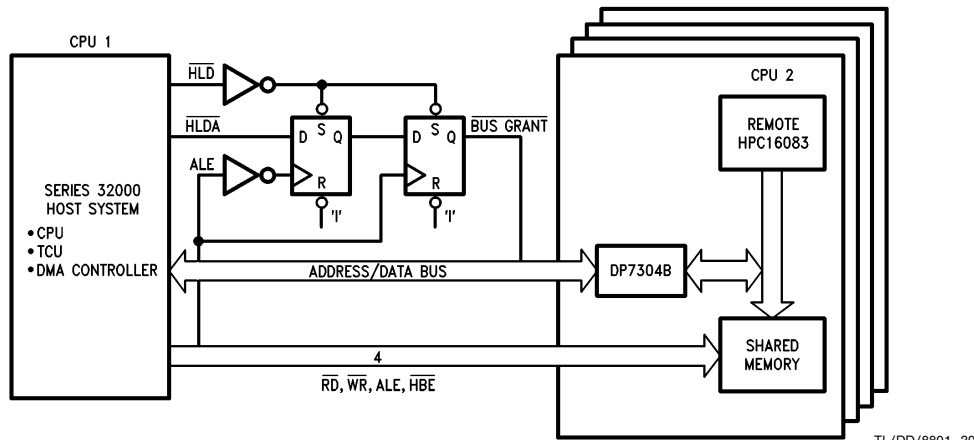

FIGURE 28. Shared Memory Application: HPC16083 Interface to Series 32000 System

TL/DD/8801-30

TABLE IV. HPC16083 Memory Map

FFFF:FFF0	Interrupt Vectors		0128	ENUR Register		
FFEF:FFD0	JSRP Vectors		0126	TBUF Register	UART	
FFCF:FFCE	On-Chip ROM	USER MEMORY	0124	RBUF Register		
: :			0122	ENUI Register		
E001:E000			0120	ENU Register		
DFFF:DFFE	External Expansion Memory		0104	Port D Input Register		
: :			00F5:00F4	BFUN Register	PORTS A & B CONTROL	
0201:0200		00F3:00F2	DIR B Register			
01FF:01FE	On-Chip RAM	USER RAM	00F1:00F0	DIR A Register / IBUF		
: :			00E6	UPIC Register	UPI CONTROL	
01C1:01C0			00E3:00E2	Port B	PORTS A & B	
0195:0194	WATCHDOG Address	WATCHDOG Logic	00E1:00E0	Port A / OBUF		
0192	T0CON Register	Timer Block T0:T3	00DE:00DF	(reserved)	PORT CONTROL & INTERRUPT CONTROL REGISTERS	
0191:0190	TMMODE Register		00DD:00DC	HALT Enable Register		
018F:018E	DIVBY Register		00D8	Port I Input Register		
018D:018C	T3 Timer		00D6	SIO Register		
018B:018A	R3 Register		00D4	IRCD Register		
0189:0188	T2 Timer		00D2	IRPD Register		
0187:0186	R2 Register		00D0	ENIR Register		
0185:0184	I2CR Register/ R1		00CF:00CE	X Register		HPC CORE REGISTERS
0183:0182	I3CR Register/ T1		00CD:00CC	B Register		
0181:0180	I4CR Register		00CB:00CA	K Register		
015E:015F	EICR	00C9:00C8	A Register			
015C	EICON	00C7:00C6	PC Register			
0153:0152	Port P Register	00C5:00C4	SP Register			
0151:0150	PWMODE Register	00C3:00C2	(reserved)	USER RAM		
014F:014E	R7 Register	00C0	PSW Register			
014D:014C	T7 Timer	00BF:00BE	On-Chip RAM			
014B:014A	R6 Register	: :				
0149:0148	T6 Timer	0001:0000				
0147:0146	R5 Register					
0145:0144	T5 Timer					
0143:0142	R4 Register					
0141:0140	T4 Timer					

Design Considerations

Designs using the HPC family of 16-bit high speed CMOS microcontrollers need to follow some general guidelines on usage and board layout.

Floating inputs are a frequently overlooked problem. CMOS inputs have extremely high impedance and, if left open, can float to any voltage. You should thus tie unused inputs to V_{CC} or ground, either through a resistor or directly. Unlike the inputs, unused outputs should be left floating to allow the output to switch without drawing any DC current.

To reduce voltage transients, keep the supply line's parasitic inductances as low as possible by reducing trace lengths, using wide traces, ground planes, and by decoupling the supply with bypass capacitors. In order to prevent additional voltage spiking, this local bypass capacitor must exhibit low inductive reactance. You should therefore use high frequency ceramic capacitors and place them very near the IC to minimize wiring inductance.

- Keep V_{CC} bus routing short. When using double sided or multilayer circuit boards, use ground plane techniques.
- Keep ground lines short, and on PC boards make them as wide as possible, even if trace width varies. Use separate ground traces to supply high current devices such as relay and transmission line drivers.
- In systems mixing linear and logic functions and where supply noise is critical to the analog components' performance, provide separate supply buses or even separate supplies.
- If you use local regulators, bypass their inputs with a tantalum capacitor of at least $1\ \mu\text{F}$ and bypass their outputs with a $10\ \mu\text{F}$ to $50\ \mu\text{F}$ tantalum or aluminum electrolytic capacitor.
- If the system uses a centralized regulated power supply, use a $10\ \mu\text{F}$ to $20\ \mu\text{F}$ tantalum electrolytic capacitor or a $50\ \mu\text{F}$ to $100\ \mu\text{F}$ aluminum electrolytic capacitor to decouple the V_{CC} bus connected to the circuit board.
- Provide localized decoupling. For random logic, a rule of thumb dictates approximately $10\ \text{nF}$ (spaced within $12\ \text{cm}$) per every two to five packages, and $100\ \text{nF}$ for every 10 packages. You can group these capacitances, but it's more effective to distribute them among the ICs. If the design has a fair amount of synchronous logic with outputs that tend to switch simultaneously, additional decoupling might be advisable. Octal flip flop and buffers in bus-oriented circuits might also require more decoupling. Note that wire-wrapped circuits can require more decoupling than ground plane or multilayer PC boards.

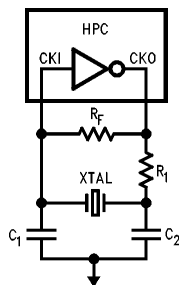

TL/DD/8801-40

FIGURE 29. Recommended Crystal Circuit

A recommended crystal oscillator circuit to be used with the HPC is shown below. See table for recommended component values. The recommended values given in the table below have yielded consistent results and are made to match a crystal with a $18\ \text{pF}$ load capacitance, with some small allowance for layout capacitance.

A recommended layout for the oscillator network should be as close to the processor as physically possible, entirely within $1''$ distance. This is to reduce lead inductance from long PC traces, as well as interference from other components, and reduce trace capacitance. The layout contains a large ground plane either on the top or bottom surface of the board to provide signal shielding, and a convenient location to ground both the HPC, and the case of the crystal.

It is very critical to have an extremely clean power supply for the HPC crystal oscillator. Ideally one would like a V_{CC} and ground plane that provide low inductance power lines to the chip. The power planes in the PC board should be decoupled with three decoupling capacitors as close to the chip as possible. A $1.0\ \mu\text{F}$, a $0.1\ \mu\text{F}$, and a $0.001\ \mu\text{F}$ dipped mica or ceramic cap mounted as close to the HPC as is physically possible on the board, using the shortest leads, or surface mount components. This should provide a stable power supply, and noiseless ground plane which will vastly improve the performance of the crystal oscillator network.

HPC Oscillator Table

XTAL Frequency (MHz)	R_1 (Ω)
≤ 2	1500
4	1200
6	910
8	750
10	600
12	470
14	390
16	300
18	220
20	180
22	150
24	120
26	100
28	75
30	62

$R_F = 3.3\ \text{M}\Omega$

$C_1 = 27\ \text{pF}$

$C_2 = 33\ \text{pF}$

XTAL Specifications: The crystal used was an M-TRON Industries MP-1 Series XTAL. "AT" cut parallel resonant

$C_L = 18\ \text{pF}$

Series Resistance is:

$25\ \Omega$ @ $25\ \text{MHz}$

$40\ \Omega$ @ $10\ \text{MHz}$

$600\ \Omega$ @ $2\ \text{MHz}$

HPC16083 CPU

The HPC16083 CPU has a 16-bit ALU and six 16-bit registers

Arithmetic Logic Unit (ALU)

The ALU is 16 bits wide and can do 16-bit add, subtract and shift or logic AND, OR and exclusive OR in one timing cycle. The ALU can also output the carry bit to a 1-bit C register.

Accumulator (A) Register

The 16-bit A register is the source and destination register for most I/O, arithmetic, logic and data memory access operations.

Address (B and X) Registers

The 16-bit B and X registers can be used for indirect addressing. They can automatically count up or down to sequence through data memory.

Boundary (K) Register

The 16-bit K register is used to set limits in repetitive loops of code as register B sequences through data memory.

Stack Pointer (SP) Register

The 16-bit SP register is the pointer that addresses the stack. The SP register is incremented by two for each push or call and decremented by two for each pop or return. The stack can be placed anywhere in user memory and be as deep as the available memory permits.

Program (PC) Register

The 16-bit PC register addresses program memory.

Addressing Modes

ADDRESSING MODES—ACCUMULATOR AS DESTINATION

Register Indirect

This is the “normal” mode of addressing for the HPC16083 (instructions are single-byte). The operand is the memory addressed by the B register (or X register for some instructions).

Direct

The instruction contains an 8-bit or 16-bit address field that directly points to the memory for the operand.

Indirect

The instruction contains an 8-bit address field. The contents of the WORD addressed points to the memory for the operand.

Indexed

The instruction contains an 8-bit address field and an 8- or 16-bit displacement field. The contents of the WORD addressed is added to the displacement to get the address of the operand.

Immediate

The instruction contains an 8-bit or 16-bit immediate field that is used as the operand.

Register Indirect (Auto Increment and Decrement)

The operand is the memory addressed by the X register. This mode automatically increments or decrements the X register (by 1 for bytes and by 2 for words).

Register Indirect (Auto Increment and Decrement) with Conditional Skip

The operand is the memory addressed by the B register. This mode automatically increments or decrements the B register (by 1 for bytes and by 2 for words). The B register is then compared with the K register. A skip condition is generated if B goes past K.

ADDRESSING MODES—DIRECT MEMORY AS DESTINATION

Direct Memory to Direct Memory

The instruction contains two 8- or 16-bit address fields. One field directly points to the source operand and the other field directly points to the destination operand.

Immediate to Direct Memory

The instruction contains an 8- or 16-bit address field and an 8- or 16-bit immediate field. The immediate field is the operand and the direct field is the destination.

Double Register Indirect Using the B and X Registers

Used only with Reset, Set and IF bit instructions; a specific bit within the 64 kbyte address range is addressed using the B and X registers. The address of a byte of memory is formed by adding the contents of the B register to the most significant 13 bits of the X register. The specific bit to be modified or tested within the byte of memory is selected using the least significant 3 bits of register X.

HPC Instruction Set Description

Mnemonic	Description	Action
ARITHMETIC INSTRUCTIONS		
ADD	Add	MA + Meml → MA carry → C
ADC	Add with carry	MA + Meml + C → MA carry → C
ADDS	Add short imm8	MA + imm8 → MA carry → C
DADC	Decimal add with carry	MA + Meml + C → MA (Decimal) carry → C
SUBC	Subtract with carry	MA – Meml + C → MA carry → C
DSUBC	Decimal subtract w/carry	MA – Meml + C → MA (Decimal) carry → C
MULT	Multiply (unsigned)	MA * Meml → MA & X, 0 → K, 0 → C
DIV	Divide (unsigned)	MA / Meml → MA, rem. → X, 0 → K, 0 → C
DIVD	Divide Double Word (unsigned)	(X & MA) / Meml → MA, rem → X, 0 → K, carry → C
IFEQ	If equal	Compare MA & Meml, Do next if equal
IFGT	If greater than	Compare MA & Meml, Do next if MA > Meml
AND	Logical and	MA and Meml → MA
OR	Logical or	MA or Meml → MA
XOR	Logical exclusive-or	MA xor Meml → MA
MEMORY MODIFY INSTRUCTIONS		
INC	Increment	Mem + 1 → Mem
DECSZ	Decrement, skip if 0	Mem – 1 → Mem, Skip next if Mem = 0

HPC Instruction Set Description (Continued)

Mnemonic	Description	Action
BIT INSTRUCTIONS		
SBIT	Set bit	1 → Mem.bit
RBIT	Reset bit	0 → Mem.bit
IFBIT	If bit	If Mem.bit is true, do next instr.
MEMORY TRANSFER INSTRUCTIONS		
LD	Load	Mem1 → MA
	Load, incr/decr X	Mem(X) → A, X ± 1 (or 2) → X
ST	Store to Memory	A → Mem
X	Exchange	A ↔ Mem
	Exchange, incr/decr X	A ↔ Mem(X), X ± 1 (or 2) → X
PUSH	Push Memory to Stack	W → W(SP), SP + 2 → SP
POP	Pop Stack to Memory	SP - 2 → SP, W(SP) → W
LDS	Load A, incr/decr B, Skip on condition	Mem(B) → A, B ± 1 (or 2) → B, Skip next if B greater/less than K
XS	Exchange, incr/decr B, Skip on condition	Mem(B) ↔ A, B ± 1 (or 2) → B, Skip next if B greater/less than K
REGISTER LOAD IMMEDIATE INSTRUCTIONS		
LD B	Load B immediate	imm → B
LD K	Load K immediate	imm → K
LD X	Load X immediate	imm → X
LD BK	Load B and K immediate	imm → B, imm → K
ACCUMULATOR AND C INSTRUCTIONS		
CLR A	Clear A	0 → A
INC A	Increment A	A + 1 → A
DEC A	Decrement A	A - 1 → A
COMP A	Complement A	1's complement of A → A
SWAP A	Swap nibbles of A	A15:12 ← A11:8 ← A7:4 ↔ A3:0
RRC A	Rotate A right thru C	C → A15 → ... → A0 → C
RLC A	Rotate A left thru C	C ← A15 ← ... ← A0 ← C
SHR A	Shift A right	0 → A15 → ... → A0 → C
SHL A	Shift A left	C ← A15 ← ... ← A0 ← 0
SC	Set C	1 → C
RC	Reset C	0 → C
IFC	IF C	Do next if C = 1
IFNC	IF not C	Do next if C = 0
TRANSFER OF CONTROL INSTRUCTIONS		
JSRP	Jump subroutine from table	PC → [SP], SP + 2 → SP W(table #) → PC
JSR	Jump subroutine relative	PC → [SP], SP + 2 → SP, PC + # → PC (# is +1025 to -1023)
JSRL	Jump subroutine long	PC → [SP], SP + 2 → SP, PC + # → PC
JP	Jump relative short	PC + # → PC (# is +32 to -31)
JMP	Jump relative	PC + # → PC (# is +257 to -255)
JMPL	Jump relative long	PC + # → PC
JID	Jump indirect at PC + A	PC + A + 1 → PC
JIDW		then Mem(PC) + PC → PC
NOP	No Operation	PC + 1 → PC
RET	Return	SP - 2 → SP, [SP] → PC
RETSK	Return then skip next	SP - 2 → SP, [SP] → PC, & skip
RETI	Return from interrupt	SP - 2 → SP, [SP] → PC, interrupt re-enabled
<p>Note: W is 16-bit word of memory MA is Accumulator A or direct memory (8 or 16-bit) Mem is 8-bit byte or 16-bit word of memory Mem1 is 8- or 16-bit memory or 8 or 16-bit immediate data imm is 8-bit or 16-bit immediate data imm8 is 8-bit immediate data only</p>		

Memory Usage

Number Of Bytes For Each Instruction (number in parenthesis is 16-Bit field)

	Using Accumulator A						To Direct Memory			
	Reg Indir.		Direct	Indir.	Index	Immed.	Direct		Immed.	
	(B)	(X)					*	**	*	**
LD	1	1	2(4)	3	4(5)	2(3)	3(5)	5(6)	3(4)	5(6)
X	1	1	2(4)	3	4(5)	—	—	—	—	—
ST	1	1	2(4)	3	4(5)	—	—	—	—	—
ADC	1	2	3(4)	3	4(5)	4(5)	4(5)	5(6)	4(5)	5(6)
ADDS	—	—	—	—	—	2	—	—	—	—
SBC	1	2	3(4)	3	4(5)	4(5)	4(5)	5(6)	4(5)	5(6)
DADC	1	2	3(4)	3	4(5)	4(5)	4(5)	5(6)	4(5)	5(6)
DSBC	1	2	3(4)	3	4(5)	4(5)	4(5)	5(6)	4(5)	5(6)
ADD	1	2	3(4)	3	4(5)	2(3)	4(5)	5(6)	4(5)	5(6)
MULT	1	2	3(4)	3	4(5)	2(3)	4(5)	5(6)	4(5)	5(6)
DIV	1	2	3(4)	3	4(5)	2(3)	4(5)	5(6)	4(5)	5(6)
DIVD	1	2	3(4)	3	4(5)	—	4(5)	5(6)	4(5)	5(6)
IFEQ	1	2	3(4)	3	4(5)	2(3)	4(5)	5(6)	4(5)	5(6)
IFGT	1	2	3(4)	3	4(5)	2(3)	4(5)	5(6)	4(5)	5(6)
AND	1	2	3(4)	3	4(5)	2(3)	4(5)	5(6)	4(5)	5(6)
OR	1	2	3(4)	3	4(5)	2(3)	4(5)	5(6)	4(5)	5(6)
XOR	1	2	3(4)	3	4(5)	2(3)	4(5)	5(6)	4(5)	5(6)

*8-bit direct address
**16-bit direct address

Instructions that modify memory directly

	(B)	(X)	Direct	Indir	Index	B&X
SBIT	1	2	3(4)	3	4(5)	1
RBIT	1	2	3(4)	3	4(5)	1
IFBIT	1	2	3(4)	3	4(5)	1
DECSZ	3	2	2(4)	3	4(5)	
INC	3	2	2(4)	3	4(5)	

Immediate Load Instructions

	Immed.
LD B,*	2(3)
LD X,*	2(3)
LD K,*	2(3)
LD BK,*,*	3(5)

Register Indirect Instructions with Auto Increment and Decrement

Register B With Skip		
	(B+)	(B-)
LDS A,*	1	1
XS A,*	1	1

Register X		
	(X+)	(X-)
LD A,*	1	1
X A,*	1	1

Instructions Using A and C

CLR	A	1
INC	A	1
DEC	A	1
COMP	A	1
SWAP	A	1
RRC	A	1
RLC	A	1
SHR	A	1
SHL	A	1
SC		1
RC		1
IFC		1
IFNC		1

Transfer of Control Instructions

JSRP	1
JSR	2
JSRL	3
JP	1
JMP	2
JMPL	3
JID	1
JIDW	1
NOP	1
RET	1
RETSK	1
RETI	1

Stack Reference Instructions

	Direct
PUSH	2
POP	2

Code Efficiency

One of the most important criteria of a single chip microcontroller is code efficiency. The more efficient the code, the more features that can be put on a chip. The memory size on a chip is fixed so if code is not efficient, features may have to be sacrificed or the programmer may have to buy a larger, more expensive version of the chip.

The HPC16083 has been designed to be extremely code-efficient. The HPC16083 looks very good in all the standard coding benchmarks; however, it is not realistic to rely only on benchmarks. Many large jobs have been programmed onto the HPC16083, and the code savings over other popular microcontrollers has been considerable.

Reasons for this saving of code include the following:

SINGLE BYTE INSTRUCTIONS

The majority of instructions on the HPC16083 are single-byte. There are two especially code-saving instructions:

JP is a 1-byte jump. True, it can only jump within a range of plus or minus 32, but many loops and decisions are often within a small range of program memory. Most other micros need 2-byte instructions for any short jumps.

JSRP is a 1-byte call subroutine. The user makes a table of the 16 most frequently called subroutines and these calls will only take one byte. Most other micros require two and even three bytes to call a subroutine. The user does not have to decide which subroutine addresses to put into the table; the assembler can give this information.

EFFICIENT SUBROUTINE CALLS

The 2-byte JSR instructions can call any subroutine within plus or minus 1k of program memory.

MULTIFUNCTION INSTRUCTIONS FOR DATA MOVEMENT AND PROGRAM LOOPING

The HPC16083 has single-byte instructions that perform multiple tasks. For example, the XS instruction will do the following:

1. Exchange A and memory pointed to by the B register
2. Increment or decrement the B register
3. Compare the B register to the K register
4. Generate a conditional skip if B has passed K

The value of this multipurpose instruction becomes evident when looping through sequential areas of memory and exiting when the loop is finished.

BIT MANIPULATION INSTRUCTIONS

Any bit of memory, I/O or registers can be set, reset or tested by the single byte bit instructions. The bits can be addressed directly or indirectly. Since all registers and I/O are mapped into the memory, it is very easy to manipulate specific bits to do efficient control.

DECIMAL ADD AND SUBTRACT

This instruction is needed to interface with the decimal user world.

It can handle both 16-bit words and 8-bit bytes.

The 16-bit capability saves code since many variables can be stored as one piece of data and the programmer does not have to break his data into two bytes. Many applications store most data in 4-digit variables. The HPC16083 supplies 8-bit byte capability for 2-digit variables and literal variables.

MULTIPLY AND DIVIDE INSTRUCTIONS

The HPC16083 has 16-bit multiply, 16-bit by 16-bit divide, and 32-bit by 16-bit divide instructions. This saves both code and time. Multiply and divide can use immediate data or data from memory. The ability to multiply and divide by immediate data saves code since this function is often needed for scaling, base conversion, computing indexes of arrays, etc.

Development Support

HPC MICROCONTROLLER DEVELOPMENT SYSTEM

National Semiconductor's HPC microcontroller development is supported through a combination of third party hardware and software, coupled with NSC in-house developed software consisting of compilers, assemblers, linkers, cross converters and debuggers. The code modules can then be transferred to many EPROM programming systems.

CUSTOMER SUPPORT

National Semiconductor's Customer Response Center (CRC) provides samples, literature, prices, product information. The CRC's engineering staff is prepared to answer questions regarding specific design and application questions regarding specific design and application questions. Call any weekday 7:00 AM to 7:00 PM central time (US) to 1-800-272-9959 or contact your regional business center.

Development Support (Continued)

DIAL-A-HELPER

Dial-A-Helper is a service provided by the Microcontroller Applications group. Dial-A-Helper is an Electronic Bulletin Board Information system and additionally, provides the capability of remotely accessing the development system at a customer site.

INFORMATION SYSTEM

The Dial-A-Helper system provides access to an automated information storage and retrieval system that may be accessed over standard dial-up telephone lines 24 hours a day. The system capabilities include a MESSAGE SECTION (electronic mail) for communications to and from the Microcontroller Applications Group and a FILE SECTION which consists of several file areas where valuable application software and utilities can be found. The minimum require-

ment for accessing Dial-A-Helper is a Hayes compatible modem.

If the user has a PC with a communications package then files from the FILE SECTION can be down loaded to disk for later use.

Order P/N: MDS-DIAL-A-HLP

Information system package contains:
DIAL-A-HELPER Users Manual
Public Domain Communications Software

FACTORY APPLICATIONS SUPPORT

Dial-A-Helper also provides immediate factory applications support.

Development Tools Selection Table

Order Number	Description	Manual Number
NSC		
HPC-DEV-IBMA	User's manuals and disks for Assembler/Linker/Librarian package for the IBM PC	424410836-001
HPC-DEV-IBMC	User's manuals and disks for C Compiler and Assembler/Linker/Librarian package for the IBM PC	424410883-001
HPC-DEV-HDB	User's manuals and disks for Source Symbolic Debugger, C Compiler and Assembler/Linker/Librarian Package for the IBM PC	424421640-001
	For use with the HP system only	424410883-001
		424410836-001
Signum		
USP-HPC	Base Unit—User's manual and screen debugger	
POD-HPC164	30 MHz POD and interface board for HPC46164	
POD-HPC064	30 MHz POD and interface board for HPC46064	
POD-HPC083	30 MHz POD and interface board for HPC46083	
POD-HPC100	40 MHz POD and interface board for HPC46100	
POD-HPC164-3	20 MHz 3.3V POD and interface board for HPC43164	
POD-HPC064-3	20 MHz 3.3V POD and interface board for HPC43064	
POD-HPC100-3	30 MHz 3.3V POD and interface board for HPC43100	
Hewlett Packard		
64700A	Card cage	
64706A	48 Channel Analyzer	
64775S	Software interface	
OPT006	Software interface to IBM PC	
64775G	HPC16083 Emulator with 128K RAM	
64775H	HPC16064 Emulator with 128K RAM	
64775J	HPC16400E Emulator with 128K RAM	
64701A	LAN Interface (Optional)	

Contact your local NSC sales office for ordering information

The Signum system comes with power supply, base unit software, RS232 link to host and emulator pod for the HPC Family member ordered. It also includes an interface connector that fits between the POD and the Target board. This system does not support development of HPC46400E based systems. Source symbolic debug capability for both assembly and C language is included in the screen debugger.

The HP model 64775 emulator/analyzer provides in system emulation up to 20 MHz, 0 wait state memory, and 30 MHz, 1 wait state memory for all devices except the HPC46400E, which is 20 MHz, 1 wait state. A reverse assembler is also available.

The recommended configuration for the IBM PC compatible host is a 386 or higher running DOS 3.0 or higher with 4 MB of extended memory. An RS232 serial port capable of running at 19.2K baud and a three button mouse is recommended for the Signum System interface.

Development Support (Continued)

Voice: (408) 721-5582
 Modem: (408) 739-1162
 Baud: 300 or 1200 Baud
 Set-Up: Length: 8-bit
 Parity: None
 Stop Bit: 1
 Operation: 24 hrs, 7 days

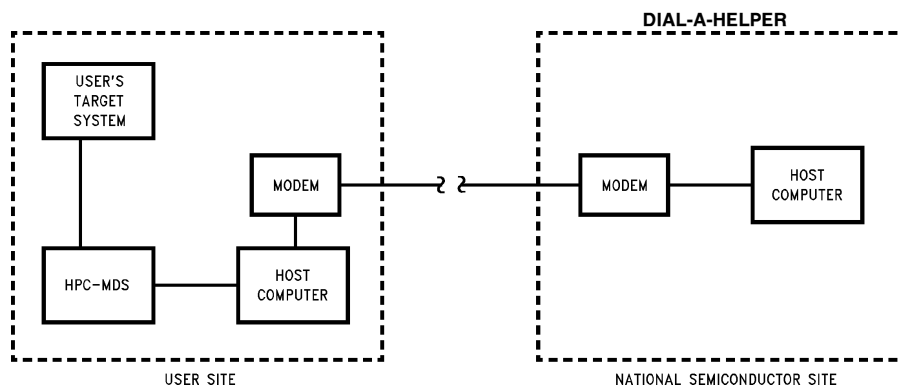

TL/DD/8801-32

Part Selection

The HPC family includes devices with many different options and configurations to meet various application needs. The number HPC16083 has been generically used throughout this datasheet to represent the whole family of parts. The following chart explains how to order various options available when ordering HPC family members.

Note: All options may not currently be available.

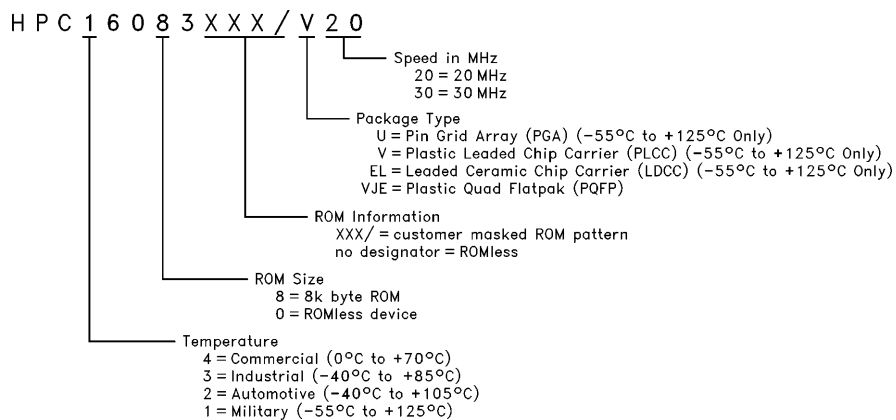

TL/DD/8801-31

FIGURE 30. HPC Family Part Numbering Scheme

Examples

HPC46003V20 — ROMless, Commercial temp. (0°C to 70°C), PLCC
 HPC16083XXX/U20 — 8k masked ROM, Military temp. (-55°C to +125°C), PGA
 HPC26083XXX/V20 — 8k masked ROM, Automotive temp. (-40°C to +105°C), PLCC

Physical Dimensions inches (millimeters)

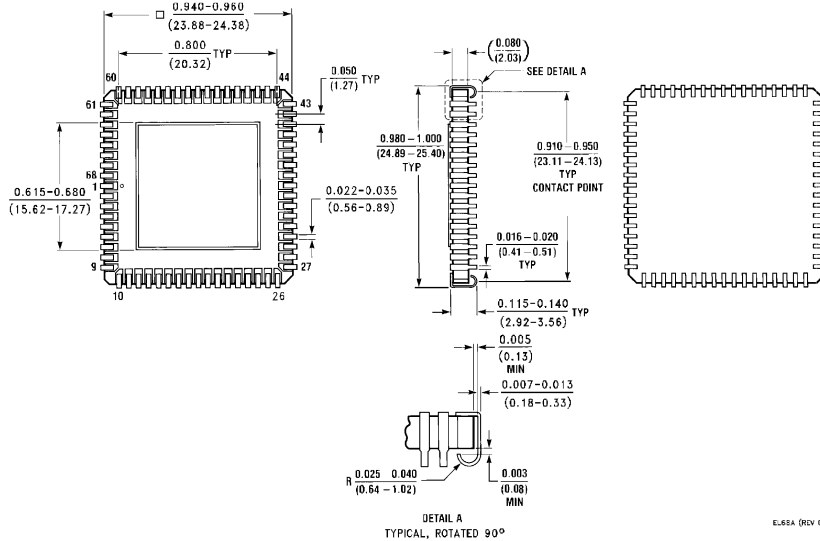

Leaded Chip Carrier Package (EL)

Order Number HPC16083XXX/L20, HPC16083XXX/L30, HPC16003EL20, HPC26003EL20, HPC36003EL20, HPC46003EL20, HPC16003EL30, HPC26003EL30, HPC36003EL30 or HPC46003EL30
NS Package Number EL68A

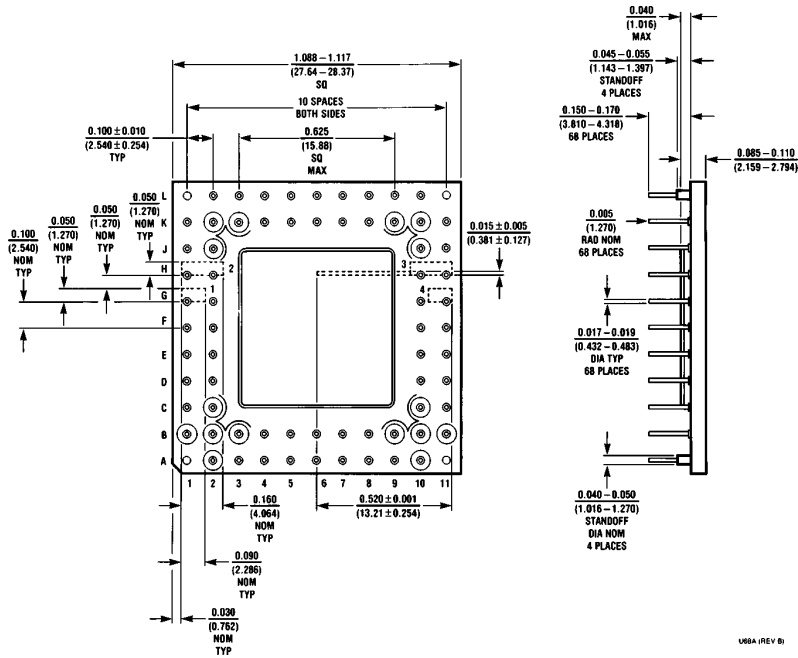

Pin Grid Array Pinout (U)

Order Number HPC16083XXX/U20, HPC16083XXX/U30, HPC16003U20 or HPC16003U30
NS Package Number U68A

Physical Dimensions inches (millimeters) (Continued)

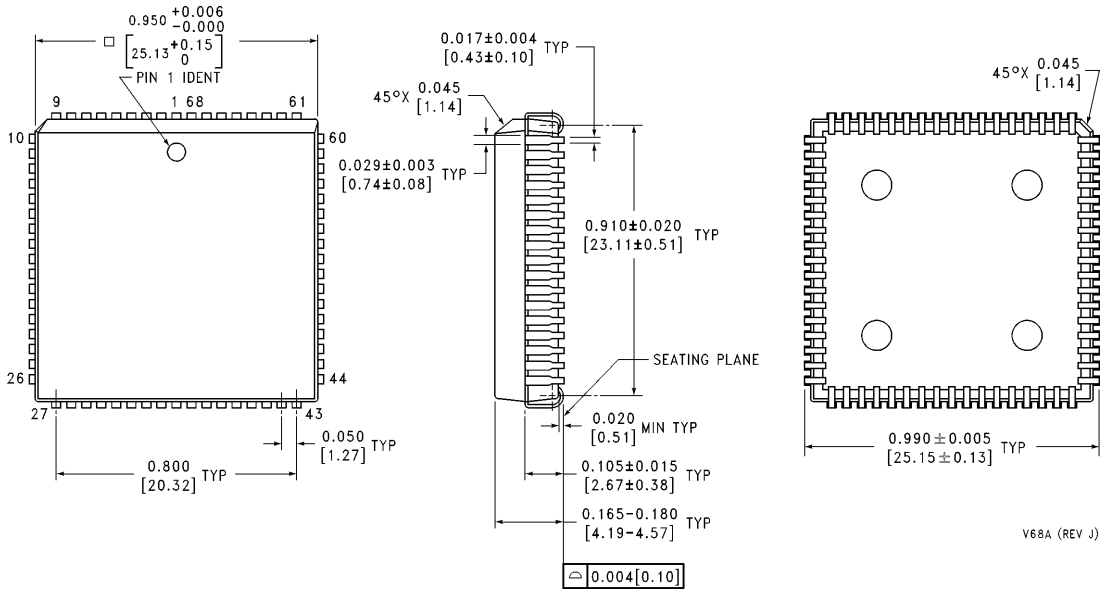

V68A (REV J)

Plastic Leaded Chip Carrier (V)

Order Number HPC16083XXX/V20, HPC26083XXX/V20, HPC36083XXX/V20, HPC46083XXX/V20, HPC16083XXX/V30, HPC26083XXX/V30, HPC36083XXX/V30, HPC16083XXX/V30, HPC16003V20, HPC26003V20, HPC36003V20, HPC46003V20, HPC16003V30, HPC26003V30, HPC36003V30 or HPC46003V30

NS Package Number V68A

Physical Dimensions inches (millimeters) (Continued)

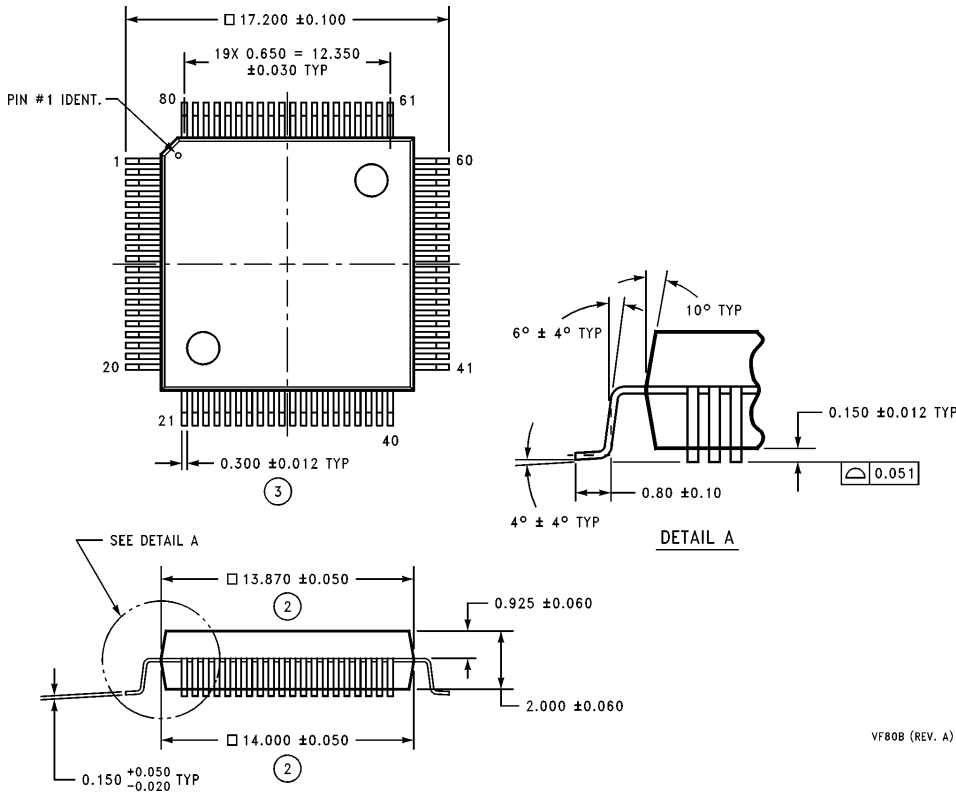

VF80B (REV. A)

80-Pin QFP Package (VF)
Order Number HPC46083XXX/F20, HPC46083XXX/F30, HPC46003VF20 or HPC46003VF30
NS Package Number VF80B

LIFE SUPPORT POLICY

NATIONAL'S PRODUCTS ARE NOT AUTHORIZED FOR USE AS CRITICAL COMPONENTS IN LIFE SUPPORT DEVICES OR SYSTEMS WITHOUT THE EXPRESS WRITTEN APPROVAL OF THE PRESIDENT OF NATIONAL SEMICONDUCTOR CORPORATION. As used herein:

1. Life support devices or systems are devices or systems which, (a) are intended for surgical implant into the body, or (b) support or sustain life, and whose failure to perform, when properly used in accordance with instructions for use provided in the labeling, can be reasonably expected to result in a significant injury to the user.
2. A critical component is any component of a life support device or system whose failure to perform can be reasonably expected to cause the failure of the life support device or system, or to affect its safety or effectiveness.



National Semiconductor Corporation
 1111 West Bardin Road
 Arlington, TX 76017
 Tel: 1(800) 272-9959
 Fax: 1(800) 737-7018

National Semiconductor Europe
 Fax: (+49) 0-180-530 85 86
 Email: onjwge@tevm2.nsc.com
 Deutsch Tel: (+49) 0-180-530 85 85
 English Tel: (+49) 0-180-532 78 32
 Français Tel: (+49) 0-180-532 93 58
 Italiano Tel: (+49) 0-180-534 16 80

National Semiconductor Hong Kong Ltd.
 19th Floor, Straight Block,
 Ocean Centre, 5 Canton Rd.
 Tsimshatsui, Kowloon
 Hong Kong
 Tel: (852) 2737-1600
 Fax: (852) 2736-9960

National Semiconductor Japan Ltd.
 Tel: 81-043-299-2309
 Fax: 81-043-299-2408

National does not assume any responsibility for use of any circuitry described, no circuit patent licenses are implied and National reserves the right at any time without notice to change said circuitry and specifications.