



MICROCHIP

LX34070
Inductive Position Sensor
EVB (EV65W60A)/Kit (EV39W84A)
User's Guide

Note the following details of the code protection feature on Microchip products:

- Microchip products meet the specifications contained in their particular Microchip Data Sheet.
- Microchip believes that its family of products is secure when used in the intended manner, within operating specifications, and under normal conditions.
- Microchip values and aggressively protects its intellectual property rights. Attempts to breach the code protection features of Microchip product is strictly prohibited and may violate the Digital Millennium Copyright Act.
- Neither Microchip nor any other semiconductor manufacturer can guarantee the security of its code. Code protection does not mean that we are guaranteeing the product is “unbreakable”. Code protection is constantly evolving. Microchip is committed to continuously improving the code protection features of our products.

This publication and the information herein may be used only with Microchip products, including to design, test, and integrate Microchip products with your application. Use of this information in any other manner violates these terms. Information regarding device applications is provided only for your convenience and may be superseded by updates. It is your responsibility to ensure that your application meets with your specifications. Contact your local Microchip sales office for additional support or, obtain additional support at <https://www.microchip.com/en-us/support/design-help/client-support-services>.

THIS INFORMATION IS PROVIDED BY MICROCHIP "AS IS". MICROCHIP MAKES NO REPRESENTATIONS OR WARRANTIES OF ANY KIND WHETHER EXPRESS OR IMPLIED, WRITTEN OR ORAL, STATUTORY OR OTHERWISE, RELATED TO THE INFORMATION INCLUDING BUT NOT LIMITED TO ANY IMPLIED WARRANTIES OF NON-INFRINGEMENT, MERCHANTABILITY, AND FITNESS FOR A PARTICULAR PURPOSE, OR WARRANTIES RELATED TO ITS CONDITION, QUALITY, OR PERFORMANCE.

IN NO EVENT WILL MICROCHIP BE LIABLE FOR ANY INDIRECT, SPECIAL, PUNITIVE, INCIDENTAL, OR CONSEQUENTIAL LOSS, DAMAGE, COST, OR EXPENSE OF ANY KIND WHATSOEVER RELATED TO THE INFORMATION OR ITS USE, HOWEVER CAUSED, EVEN IF MICROCHIP HAS BEEN ADVISED OF THE POSSIBILITY OR THE DAMAGES ARE FORESEEABLE. TO THE FULLEST EXTENT ALLOWED BY LAW, MICROCHIP'S TOTAL LIABILITY ON ALL CLAIMS IN ANY WAY RELATED TO THE INFORMATION OR ITS USE WILL NOT EXCEED THE AMOUNT OF FEES, IF ANY, THAT YOU HAVE PAID DIRECTLY TO MICROCHIP FOR THE INFORMATION.

Use of Microchip devices in life support and/or safety applications is entirely at the buyer's risk, and the buyer agrees to defend, indemnify and hold harmless Microchip from any and all damages, claims, suits, or expenses resulting from such use. No licenses are conveyed, implicitly or otherwise, under any Microchip intellectual property rights unless otherwise stated.

For information regarding Microchip's Quality Management Systems, please visit www.microchip.com/quality.

Trademarks

The Microchip name and logo, the Microchip logo, Adaptec, AnyRate, AVR, AVR logo, AVR Freaks, BesTime, BitCloud, CryptoMemory, CryptoRF, dsPIC, flexPWR, HELDO, IGLOO, JukeBlox, KeeLoq, Kleer, LANCheck, LinkMD, maXStylus, maXTouch, MediaLB, megaAVR, Microsemi, Microsemi logo, MOST, MOST logo, MPLAB, OptoLyzer, PIC, picoPower, PICSTART, PIC32 logo, PolarFire, Prochip Designer, QTouch, SAM-BA, SenGenuity, SpyNIC, SST, SST Logo, SuperFlash, Symmetricom, SyncServer, Tachyon, TimeSource, tinyAVR, UNI/O, Vectron, and XMEGA are registered trademarks of Microchip Technology Incorporated in the U.S.A. and other countries.

AgileSwitch, APT, ClockWorks, The Embedded Control Solutions Company, EtherSynch, Flashtec, Hyper Speed Control, HyperLight Load, IntelliMOS, Libero, motorBench, mTouch, Powermite 3, Precision Edge, ProASIC, ProASIC Plus, ProASIC Plus logo, QuietWire, SmartFusion, SyncWorld, Temux, TimeCesium, TimeHub, TimePictra, TimeProvider, TrueTime, WinPath, and ZL are registered trademarks of Microchip Technology Incorporated in the U.S.A.

Adjacent Key Suppression, AKS, Analog-for-the-Digital Age, Any Capacitor, AnyIn, AnyOut, Augmented Switching, BlueSky, BodyCom, CodeGuard, CryptoAuthentication, CryptoAutomotive, CryptoCompanion, CryptoController, dsPICDEM, dsPICDEM.net, Dynamic Average Matching, DAM, ECAN, Espresso T1S, EtherGREEN, GridTime, IdealBridge, In-Circuit Serial Programming, ICSP, INICnet, Intelligent Paralleling, Inter-Chip Connectivity, JitterBlocker, Knob-on-Display, maxCrypto, maxView, memBrain, Mindi, MiWi, MPASM, MPF, MPLAB Certified logo, MPLIB, MPLINK, MultiTRAK, NetDetach, NVM Express, NVMe, Omniscient Code Generation, PICDEM, PICDEM.net, PICkit, PICTail, PowerSmart, PureSilicon, QMatrix, REAL ICE, Ripple Blocker, RTAX, RTG4, SAM-ICE, Serial Quad I/O, simpleMAP, SimpliPHY, SmartBuffer, SmartHLS, SMART-I.S., storClad, SQL, SuperSwitcher, SuperSwitcher II, Switchtec, SynchroPHY, Total Endurance, TSHARC, USBCheck, VariSense, VectorBlox, VeriPHY, ViewSpan, WiperLock, XpressConnect, and ZENA are trademarks of Microchip Technology Incorporated in the U.S.A. and other countries.

SQTP is a service mark of Microchip Technology Incorporated in the U.S.A.

The Adaptec logo, Frequency on Demand, Silicon Storage Technology, Symmcom, and Trusted Time are registered trademarks of Microchip Technology Inc. in other countries.

GestIC is a registered trademark of Microchip Technology Germany II GmbH & Co. KG, a subsidiary of Microchip Technology Inc., in other countries.

All other trademarks mentioned herein are property of their respective companies.

© 2022, Microchip Technology Incorporated and its subsidiaries.

All Rights Reserved.

ISBN: 978-1-5224-9955-8



LX34070 INDUCTIVE POSITION SENSOR EVB (EV65W60A)/KIT (EV39W84A) USER'S GUIDE

Table of Contents

Preface	5
Introduction.....	5
Document Layout	5
Conventions Used in this Guide	6
Recommended Reading.....	7
The Microchip Website	7
Product Change Notification Service.....	7
Customer Support	7
Document Revision History	7
Chapter 1. Product Overview	
1.1 Introduction	9
1.2 Features	9
1.3 LX34070 90 Degree Rotary EVB (EV65W60A)/Kit (EV39W84A) Contents ...	9
1.4 Quick Start Guide	10
Chapter 2. Technical Operation	
2.1 Introduction	11
2.2 System Operation	11
2.3 Details of Connectors on Sensor Board	12
2.4 Inductive Sensor Board Typical Characteristics	13
Worldwide Sales and Service	14

NOTES:



LX34070 INDUCTIVE POSITION SENSOR EV6 (EV65W60A)/KIT (EV39W84A) USER'S GUIDE

Preface

NOTICE TO CUSTOMERS

All documentation becomes dated, and this manual is no exception. Microchip tools and documentation are constantly evolving to meet customer needs, so some actual dialogs and/or tool descriptions may differ from those in this document. Please refer to our website (www.microchip.com) to obtain the latest documentation available.

Documents are identified with a “DS” number. This number is located on the bottom of each page, in front of the page number. The numbering convention for the DS number is “DSXXXXXXXXA”, where “XXXXXXXX” is the document number and “A” is the revision level of the document.

For the most up-to-date information on development tools, see the MPLAB® IDE online help. Select the Help menu, and then Topics to open a list of available online help files.

INTRODUCTION

This chapter contains general information that will be useful to know before using the LX34070 90 Degree Rotary EVB (EV65W60A)/Kit (EV39W84A). Items discussed in this chapter include:

- [Document Layout](#)
- [Conventions Used in this Guide](#)
- [Recommended Reading](#)
- [The Microchip Website](#)
- [Customer Support](#)
- [Document Revision History](#)

DOCUMENT LAYOUT

This document describes how to use the LX34070 90 Degree Rotary EVB (EV65W60A)/Kit (EV39W84A) as a development tool to emulate and debug firmware on a target board. The user's guide layout is as follows:

- **Chapter 1. “Product Overview”** – This chapter describes the most important features of the LX34070 90 Degree Rotary EVB (EV65W60A)/Kit (EV39W84A), as well as the contents of the kit and a step-by-step Quick Start Guide.
- **Chapter 2. “Technical Operation”** – This chapter provides technical details important for the operation of the LX34070 90 Degree Rotary EVB (EV65W60A)/Kit (EV39W84A).

CONVENTIONS USED IN THIS GUIDE

This manual uses the following documentation conventions:

DOCUMENTATION CONVENTIONS

Description	Represents	Examples
Arial font:		
Italic characters	Referenced books	<i>MPLAB® IDE User's Guide</i>
	Emphasized text	...is the <i>only</i> compiler...
Initial caps	A window	the Output window
	A dialog	the Settings dialog
	A menu selection	select Enable Programmer
Quotes	A field name in a window or dialog	"Save project before build"
Underlined, italic text with right angle bracket	A menu path	<u>File</u> > <i>Save</i>
Bold characters	A dialog button	Click OK
	A tab	Click the Power tab
N'Rnnnn	A number in verilog format, where N is the total number of digits, R is the radix and n is a digit.	4'b0010, 2'hF1
Text in angle brackets < >	A key on the keyboard	Press <Enter>, <F1>
Courier New font:		
Plain Courier New	Sample source code	#define START
	Filenames	autoexec.bat
	File paths	c:\mcc18\h
	Keywords	_asm, _endasm, static
	Command-line options	-Opa+, -Opa-
	Bit values	0, 1
	Constants	0xFF, 'A'
Italic Courier New	A variable argument	<i>file.o</i> , where <i>file</i> can be any valid filename
Square brackets []	Optional arguments	mcc18 [options] <i>file</i> [options]
Curly brackets and pipe character: { }	Choice of mutually exclusive arguments; an OR selection	errorlevel {0 1}
Ellipses...	Replaces repeated text	var_name [, var_name...]
	Represents code supplied by user	void main (void) { ... }

RECOMMENDED READING

This user's guide describes how to use the LX34070 90 Degree Rotary EVB/Kit. Other useful and supplemental documents will be listed here when they become available:

THE MICROCHIP WEBSITE

Microchip provides online support via our website at www.microchip.com. This website is used as a means to make files and information easily available to customers. Accessible by using your favorite Internet browser, the website contains the following information:

- **Product Support** – Data sheets and errata, application notes and sample programs, design resources, user's guides and hardware support documents, latest software releases and archived software
- **General Technical Support** – Frequently Asked Questions (FAQs), technical support requests, online discussion groups, Microchip consultant program member listing
- **Business of Microchip** – Product selector and ordering guides, latest Microchip press releases, listing of seminars and events, listings of Microchip sales offices, distributors and factory representatives

PRODUCT CHANGE NOTIFICATION SERVICE

Microchip's customer notification service helps keep customers current on Microchip products. Subscribers will receive email notifications whenever there are changes, updates, revisions or errata related to a specified product family or development tool of interest.

To register, access the Microchip website at www.microchip.com, click on **Product Change Notification** and follow the registration instructions.

CUSTOMER SUPPORT

Users of Microchip products can receive assistance through several channels:

- Distributor or Representative
- Local Sales Office
- Field Application Engineer (FAE)
- Technical Support

It is recommended that customers contact their distributor, representative or field application engineer (FAE) for support. Local sales offices are also available to help customers. A listing of sales offices and locations is included in the back of this document.

Technical support is available through the website at:
<http://www.microchip.com/support>

DOCUMENT REVISION HISTORY

Revision A (March 2022)

- Initial release of this document.

NOTES:

Chapter 1. Product Overview

1.1 INTRODUCTION

This chapter provides an overview of the LX34070 90 Degree Rotary EVB (EV65W60A)/Kit (EV39W84A), as well as a Quick Start Guide.

Sensor development with an LX34070 90 Degree Rotary EVB (EV65W60A)/Kit (EV39W84A) offers differential outputs, higher accuracy, high speed applications; it is immune to motor noise and does not need a magnetic target. The sensor system consists of the inductive position sensor IC (LX34070), its printed circuit board sensor and the target. A target metal is attached to the moving mechanical housing, which provides position relative to the fixed position of the sensor Printed Circuit Board (PCB).

For remote sensor applications, the sensor module will communicate analog position information to a host processing system over a 8-wire cable; the necessary signals to the processor are power, ground, and the two differential analog position signals.

1.2 FEATURES

The LX34070 90 Degree Rotary EVB (EV65W60A)/Kit (EV39W84A) has the following features.

- Differential outputs for low noise and output signal distortion.
- High bandwidth: 100 kHz (<5 μ s latency), so the sensor is used for high-speed resolver applications.
- Independently adjustable offset and gain for output analog signals.
- Programming via power pin or GPIO pin using LXM9518 programmer.

1.3 LX34070 90 DEGREE ROTARY EVB (EV65W60A)/KIT (EV39W84A) CONTENTS

The LX34070 90 Degree Rotary EVB (EV65W60A)/Kit (EV39W84A) contains the following items:

1. Inductive position sensor PCB with target assembly
2. Interfacing cable for the LXM9518 programmer
3. Interfacing cable for monitoring the outputs
4. LXM9518 with USB cable to connect to PC (Kit only)
5. The IPCE software can be downloaded from www.microchip.com

Figure 1-1 shows a picture of LX34070 90 Degree Rotary EVB (EV65W60A)

Figure 1-2 shows a picture of LX34070 90 Degree Rotary Kit (EV39W84A)



FIGURE 1-1: LX34070 90 Degree Rotary EVB (EV65W60A).



FIGURE 1-2: LX34070 90 Degree Rotary Kit (EV39W84A).

1.4 QUICK START GUIDE

The LX34070 90 Degree Rotary EVB (EV65W60A)/Kit (EV39W84A) includes an Integrated Programming and Calibration Environment (IPCE) to facilitate system calibration and configuration. The integrated programming environment contains an EEPROM programming tool and data measuring system.

Follow these steps to install and start operating the LX34070 90 Degree Rotary EVB (EV65W60A)/Kit (EV39W84A):

1. Go to www.microchip.com, navigate to the LX34070 product page and under the "Embedded Software" section, download the LX34070 IPCE GUI and Firmware Release Beta Version (001), from myMicrochip account.
2. Install the program.
3. Connect LXM9518 programmer USB cable to PC and connect another end to Sensor Board using the supplied cable.
4. Open the installed IPCE program and follow the instructions showed on IPCE to update the firmware for LXM9518 programmer.
5. As the Inductive sensor IC is pre-loaded with Golden parameters and the programmer is updated with respective firmware, the IPCE will automatically detects the sensor.
6. At this point, the sensor can be customized to the user's needs. To optimize the system performance, the manual calibration guide should be downloaded and the steps in the document followed.

Chapter 2. Technical Operation

2.1 INTRODUCTION

This chapter explains the key technical aspects of the LX34070 90 Degree Rotary EVB/Kit. It begins with a brief discussion of the system operation of the LX34070 90 Degree Rotary EVB/Kit, features a picture of the board and connector pinout instructions, and concludes with an example diagram of linearity

2.2 SYSTEM OPERATION

The LX34070 90 Degree Rotary EVB/Kit has been factory calibrated and is ready to use. The EVB constitutes a main sensor board and a movable target PCB. The main sensor board contains two oscillator coils (EX1 and EX2) and two pickup coils (RM1 and RM2). The IC energizes the two oscillator coils. The position of the target varies the reception of the two pickup coils relative to each other. The IC demodulates the two received signals and generates sine and cosine differential analog output signals (OUT1P, OUT1N, OUT2P and OUT2N) representative of the relative difference between the RM1 and RM2 signals, see Figure 2-1.

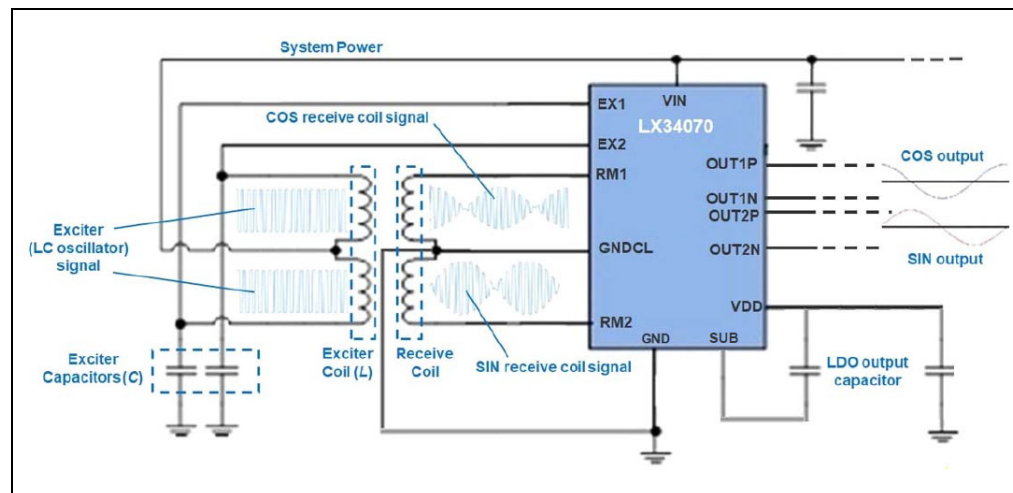

FIGURE 2-1: Inductive Sensor Operation Principle.

2.3 DETAILS OF CONNECTORS ON SENSOR BOARD

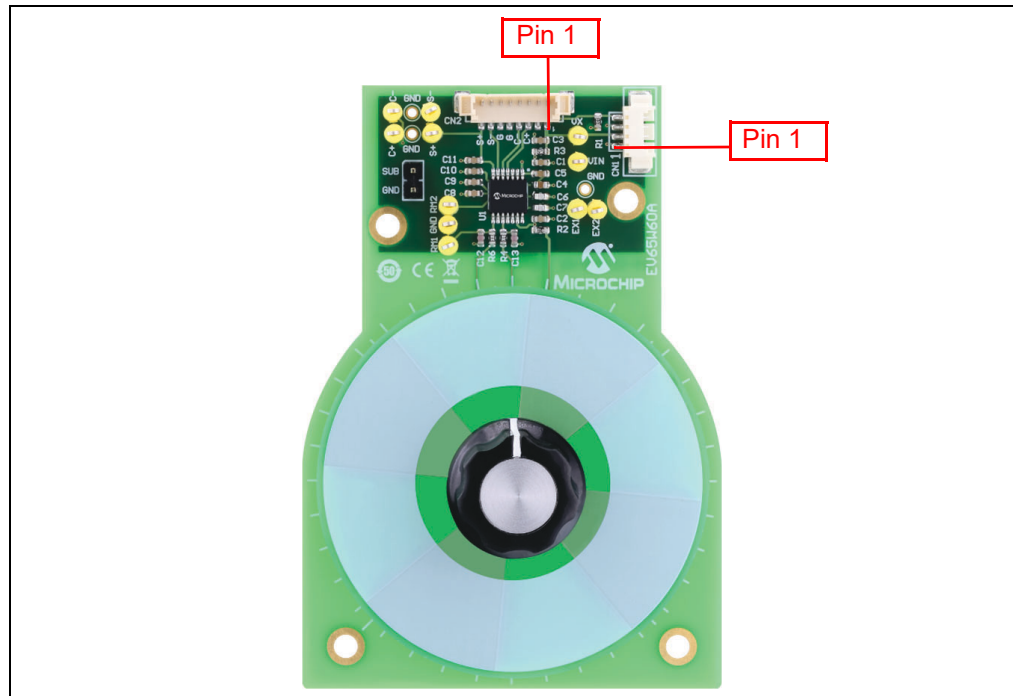

FIGURE 2-2: LX34070 90 Degree Rotary EVB (EV65W60A).

The sensor assembly comes with a 4-pin (CN1) to 10-pin connector for programming using LXM9518 programmer (Table 2-2 and Table 2-3 shows the pinout of this connector) and 8-pin (CN2) connector for outputs monitoring (Table 2-1 shows the pinout of this connector).

TABLE 2-1: CN2 CONNECTOR PINOUT

Pin#	Pin Name	Functional Description
1	VIN	External +5V supply
2	GND	Ground
3	OUT2P	Demodulated SIN receives coil positive (+) output
4	OUT2N	Demodulated SIN receives coil negative (-) output
5	GND	Ground
6	GND	Ground
7	OUT1N	Demodulated COS receives coil negative (-) output
8	OUT1P	Demodulated SIN receives coil positive (+) output



FIGURE 2-3: 4-pin (CN1) to 10-pin (CN3) Connector.

TABLE 2-2: CN1 CONNECTOR PINOUT

Pin#	Pin Name	Functional Description
1	GND	Ground
2	VIN	+5V Supply
3	TEST	GPIO program pin for the device
4	OUT1N	Digital Input/Output pin for EEPROM programming

TABLE 2-3: CN3 CONNECTOR PINOUT

Pin#	Pin Name	Functional Description
1	OUT1N	Digital Input/Output pin for EEPROM programming
2	TEST	GPIO program pin for the device
3	VIN	+5V Supply
4	GND	Ground
5	SDA	I2C serial data (internal purpose only, not for external use) Reserved
6	SCL	I2C serial clock (internal purpose only, not for external use) Reserved
7	IO1 (ICSPCLK)	Only used for digital programming mode (Clock for programming internal microcontroller)
8	IO4 (ICSPDAT)	Only used for digital programming mode (Data line for programming internal microcontroller)
9	MCLR	Master Clear (used for programming internal microcontroller)
10	VDD	Internal device supply

2.4 INDUCTIVE SENSOR BOARD TYPICAL CHARACTERISTICS

The plot in Figure 2-4 displays an example of linearity achievable with the inductive sensor (5 pole pair) with an analog output. The Error plot is the zoomed difference between the ideal slope (red) and the Analog output (blue).

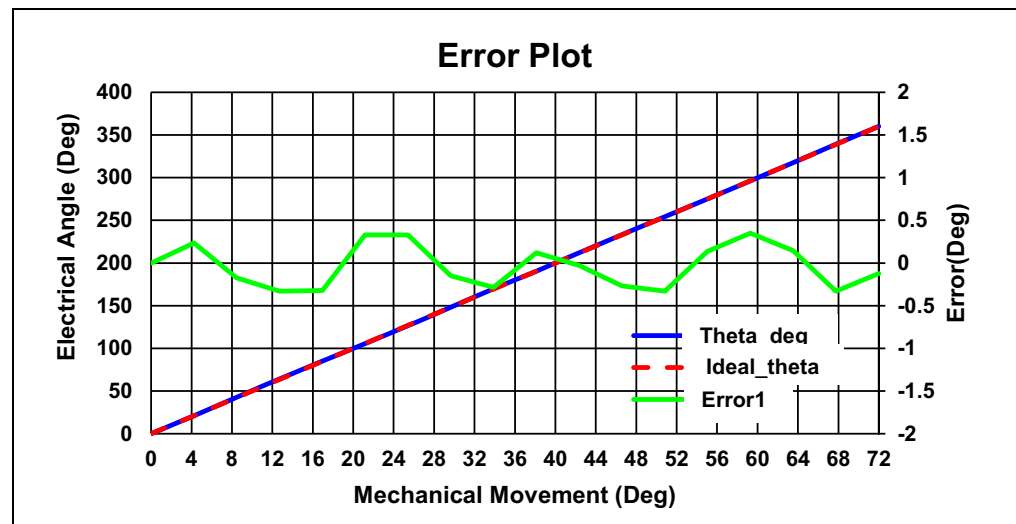

FIGURE 2-4: An Example of Typical Inductive Sensor Board Linearity.



MICROCHIP

Worldwide Sales and Service

AMERICAS

Corporate Office
2355 West Chandler Blvd.
Chandler, AZ 85224-6199
Tel: 480-792-7200
Fax: 480-792-7277
Technical Support:
<http://www.microchip.com/support>
Web Address:
www.microchip.com

Atlanta

Duluth, GA
Tel: 678-957-9614
Fax: 678-957-1455

Austin, TX

Tel: 512-257-3370

Boston

Westborough, MA
Tel: 774-760-0087
Fax: 774-760-0088

Chicago

Itasca, IL
Tel: 630-285-0071
Fax: 630-285-0075

Dallas

Addison, TX
Tel: 972-818-7423
Fax: 972-818-2924

Detroit

Novi, MI
Tel: 248-848-4000

Houston, TX

Tel: 281-894-5983

Indianapolis

Noblesville, IN
Tel: 317-773-8323
Fax: 317-773-5453
Tel: 317-536-2380

Los Angeles

Mission Viejo, CA
Tel: 949-462-9523
Fax: 949-462-9608
Tel: 951-273-7800

Raleigh, NC

Tel: 919-844-7510

New York, NY

Tel: 631-435-6000

San Jose, CA

Tel: 408-735-9110
Tel: 408-436-4270

Canada - Toronto

Tel: 905-695-1980
Fax: 905-695-2078

ASIA/PACIFIC

Australia - Sydney
Tel: 61-2-9868-6733

China - Beijing
Tel: 86-10-8569-7000

China - Chengdu
Tel: 86-28-8665-5511

China - Chongqing
Tel: 86-23-8980-9588

China - Dongguan
Tel: 86-769-8702-9880

China - Guangzhou
Tel: 86-20-8755-8029

China - Hangzhou
Tel: 86-571-8792-8115

China - Hong Kong SAR
Tel: 852-2943-5100

China - Nanjing
Tel: 86-25-8473-2460

China - Qingdao
Tel: 86-532-8502-7355

China - Shanghai
Tel: 86-21-3326-8000

China - Shenyang
Tel: 86-24-2334-2829

China - Shenzhen
Tel: 86-755-8864-2200

China - Suzhou
Tel: 86-186-6233-1526

China - Wuhan
Tel: 86-27-5980-5300

China - Xian
Tel: 86-29-8833-7252

China - Xiamen
Tel: 86-592-2388138

China - Zhuhai
Tel: 86-756-3210040

ASIA/PACIFIC

India - Bangalore
Tel: 91-80-3090-4444

India - New Delhi
Tel: 91-11-4160-8631

India - Pune
Tel: 91-20-4121-0141

Japan - Osaka
Tel: 81-6-6152-7160

Japan - Tokyo
Tel: 81-3-6880-3770

Korea - Daegu
Tel: 82-53-744-4301

Korea - Seoul
Tel: 82-2-554-7200

Malaysia - Kuala Lumpur
Tel: 60-3-7651-7906

Malaysia - Penang
Tel: 60-4-227-8870

Philippines - Manila
Tel: 63-2-634-9065

Singapore
Tel: 65-6334-8870

Taiwan - Hsin Chu
Tel: 886-3-577-8366

Taiwan - Kaohsiung
Tel: 886-7-213-7830

Taiwan - Taipei
Tel: 886-2-2508-8600

Thailand - Bangkok
Tel: 66-2-694-1351

Vietnam - Ho Chi Minh
Tel: 84-28-5448-2100

EUROPE

Austria - Wels
Tel: 43-7242-2244-39
Fax: 43-7242-2244-393

Denmark - Copenhagen
Tel: 45-4485-5910
Fax: 45-4485-2829

Finland - Espoo
Tel: 358-9-4520-820

France - Paris
Tel: 33-1-69-53-63-20
Fax: 33-1-69-30-90-79

Germany - Garching
Tel: 49-8931-9700

Germany - Haan
Tel: 49-2129-3766400

Germany - Heilbronn
Tel: 49-7131-72400

Germany - Karlsruhe
Tel: 49-721-625370

Germany - Munich
Tel: 49-89-627-144-0
Fax: 49-89-627-144-44

Germany - Rosenheim
Tel: 49-8031-354-560

Israel - Ra'anana
Tel: 972-9-744-7705

Italy - Milan
Tel: 39-0331-742611
Fax: 39-0331-466781

Italy - Padova
Tel: 39-049-7625286

Netherlands - Drunen
Tel: 31-416-690399
Fax: 31-416-690340

Norway - Trondheim
Tel: 47-7288-4388

Poland - Warsaw
Tel: 48-22-3325737

Romania - Bucharest
Tel: 40-21-407-87-50

Spain - Madrid
Tel: 34-91-708-08-90
Fax: 34-91-708-08-91

Sweden - Gothenberg
Tel: 46-31-704-60-40

Sweden - Stockholm
Tel: 46-8-5090-4654

UK - Wokingham
Tel: 44-118-921-5800
Fax: 44-118-921-5820