

Trimmer Potentiometers /Rotary Position Sensors

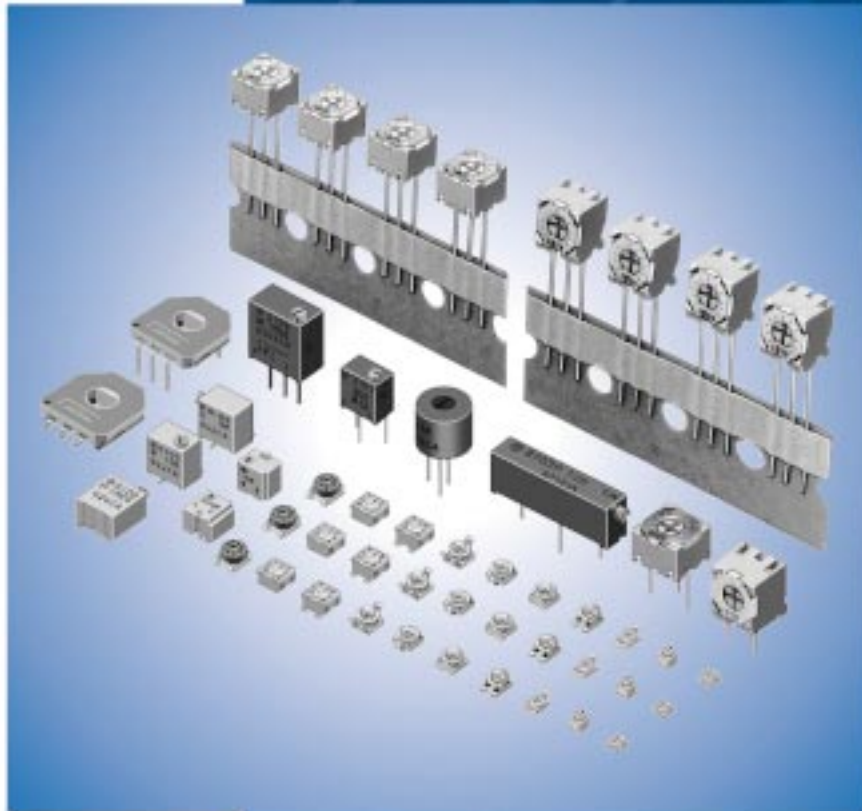

CONTENTS

Part Numbering	2
Selection Guide of Trimmer Potentiometers	5
1 SMD Open Type 2mm Size PVZ2/PVA2 Series	6
● PVZ2/PVA2 Series Notice	10
2 SMD Open Type 3mm Size PVZ3/PVS3/PVA3 Series	12
● PVZ3/PVS3/PVA3 Series Notice	19
3 SMD Sealed Type 2mm Size PVF2 Series	22
● PVF2 Series Notice	24
4 SMD Sealed Type 3mm Size PVG3 Series	26
● PVG3 Series Notice	29
5 SMD Sealed Type 4mm Size PVM4 Series	31
● PVM4 Series Notice	33
6 SMD Sealed Type Multi-turns PVG5/PV01 Series	36
● PVG5/PV01 Series Notice	40
7 Lead Sealed Type Single-turn PVC6/PV32/PV34 Series	42
● PVC6/PV32/PV34 Series Notice	52
8 Lead Sealed Type Multi-turns PV12/PV37/PV23/PV22/PV36 Series	54
● PV12/PV37/PV23/PV22/PV36 Series Notice	67
9 Rotary Position Sensors SMD/Lead Dust-proof Type 12mm Size SV01 Series	69
● SV01 Series Notice	71
10 Rotary Position Sensors Connector Dust-proof Type SV21 Series	73
● SV21 Series Notice	74
SMD Open Type (PVZ2/A2/Z3/S3/A3)/SMD Sealed Type (PVM4A_C01 Series) Specifications and Test Methods	75
SMD Sealed Type (PVF2/G3/M4A_D01/G5/01)/Lead Sealed Type (PVC6/32/34/12/37/23/22/36) Specifications and Test Methods	77
Rortary Position Sensors SMD/Lead Dust-proof Type (SV01) Specifications and Test Methods	80
Rortary Position Sensors Connector Dust-proof Type (SV21) Specifications and Test Methods	81
Packaging	82
Recommended Adjustment Tools/Qualified Standards	87
<ul style="list-style-type: none"> • The RoHS compliance means that we judge from EU Directive 2002/95/EC the products do not contain lead, cadmium, mercury, hexavalent chromium, PBB and PBDE, except exemptions stated in EU Directive 2002/95/EC annex and impurities existing in natural world. • This statement does not insure the compliance of any of the listed parts with any laws or legal imperatives developed by any EU members individually with regards to the RoHS Directive. 	

● Part Numbering

Trimmer Potentiometers

(Part Number)

PV	Z3	A	103	A01	R00
①	②	③	④	⑤	⑥

① Product ID

Product ID	
PV	Trimmer Potentiometers

② Series

③ Adjustment Direction /Lead Type

Code	Series	Code	Adjustment Direction/ Lead Type
Z2	SMD Open 2mm Size Carbon Resistive Element	A	Top
		K	Rear
		R	Rear
A2	SMD Open 2mm Size	A	Top
Z3	SMD Open 3mm Size Carbon Resistive Element	A	Top
		K	Rear
		R	Rear
S3	SMD Open 3mm Size Stopper Low-profile	A	Top
A3	SMD Open 3mm Size	A	Top
F2	SMD Sealed 2mm Size	A	Top
G3	SMD Sealed 3mm Size	A	Top, J-hook
		G	Top, Gull-wing
		K	Rear
M4	SMD Sealed 4mm Size	A	Top
G5	SMD Sealed 5mm Square 11-turns	A	Top
		H	Side
01	SMD Sealed 6mm Square 12-turns	P	Side
		W	Top
		X	Side
C6	Lead Sealed 6mm Square Single-turn	A	Top, Triangle
		D	Top, Triangle
		E	Side, Triangle
		G	Side, Triangle
		H	Side, Triangle
		M	Top, Inline
		Q	Side, Inline
32	Lead Sealed 6mm Round Single-turn	H	Top, Triangle
		P	Top, Triangle
		R	Top, Inline
		N	Side, Triangle
		T	Side, Triangle
		S	Side, Triangle
34	Lead Sealed 9mm Square Single-turn	F	Top, Triangle
		P	Top, Triangle
		H	Side, Triangle
		X	Side, Triangle
		W	Side, Inline
12	Lead Sealed 7mm Round 4-turns	H	Top, Triangle
		P	Top, Triangle
		T	Side, Triangle
		S	Side, Triangle

22	Lead Sealed 31mm Rectangular 22-turns	L	Side
		S	Side, Inline
		Y	Side, Triangle
23	Lead Sealed 19mm Rectangular 15-turns	P	Side, Triangle
		Y	Side, Triangle
36	Lead Sealed 10mm Square 25-turns	W	Top, Inline
		Y	Top, Triangle
		P	Side, Triangle
		X	Side, Inline
37	Lead Sealed 6mm Square 12-turns	Z	Side, Triangle
		W	Top, Triangle
		Y	Top, Inline
		P	Side, Triangle
		X	Side, Triangle
		Z	Side, Inline

④ Total Resistance

Expressed by three figures. The unit is ohm. The first and second figures are significant digits, and the third figure expresses the number of zeros which follow the two figures.

Ex.)	Code	Total Resistance
	100	10Ω
	102	1000Ω
	104	100000Ω (=100kΩ)

Continued on the following page. 

☐ Continued from the preceding page.

⑤ Individual Specification

Series	Code	Individual Specification Code
PVA2/PVS3/PVA3	A01	Standard Type
PVZ2	A01	Standard Type
	A04	Ultra-thin Type
	C01	High-heat Resistance Type
	C04	High-heat Resistance Type (for Ultra-thin Type)
PVZ3	A01	Standard Type (for Top Adjustment)
	C01	High-heat Resistance Type (for Top Adjustment)
	E01	High-heat Resistance Type (for Rear Adjustment)
PVM4	C01	Standard Type
	D01	High-liability Type
PVF2	A11	Standard Type (Resistance Change Characteristics: Linear)
	A41	Standard Type (Resistance Change Characteristics: Log Curve)
	A81	Standard Type (Resistance Change Characteristics: Log Curve)
	A51	Standard Type (Resistance Change Characteristics: Log-log Curve)
	A91	Standard Type (Resistance Change Characteristics: Log-log Curve)
PV32/PV12	A01	Standard Type
PVG3/PVG5/PV01/ PV22/PV23/ PV34/PV36/PV37	C01	Standard Type
PVC6	C01	Standard Type
	C04	Radial Taping
PV36/PV37	C01	Standard Type
	C31	Radial Taping

⑥ Packaging

Code	Packaging
A00	Ammo Pack
B00	Bulk
M00*	Magazine
R00	Reel

* M12 for PV36P Type and M15 for PV36W/Y/X/Z Type.

Rotary Position Sensor

(Part Number)

SV	01	A	103	AE	A01	R00
①	②	③	④	⑤	⑥	⑦

① Product ID

Product ID	
SV	Rotary Position Sensor

② Series

Code	Series
01	Carbon Rotary Position Sensor

③ Terminal Shape

Code	Terminal Shape
A	SMD Type
L	Lead Type

④ Total Resistance

Expressed by three figures. The unit is ohm. The first and second figures are significant digits, and the third figure expresses the number of zeros which follow the two figures.

Ex.)

Code	Total Resistance
103	10000Ω (=10kΩ)

⑤ Rotor Hole Shape/Rotor Hole Size

Code	Rotor Hole Shape/Rotor Hole Size
AD	D Hole/3.5mm Dia.
AE	D Hole/4.0mm Dia.
CE	T Hole/4.0mm Dia.

⑥ Individual Specification Code

Code	Individual Specification Code
A01	SMD Type Standard
A11	Lead Type Standard

⑦ Packaging

Code	Packaging
B00	Bulk
R00	Reel
T00	Tray

(Part Number)

SV	21	C	201	BJ	A01	B00
①	②	③	④	⑤	⑥	⑦

① Product ID

Product ID	
SV	Rotary Position Sensor

② Series

Code	Series
21	Hole IC Rotary Position Sensor

③ Terminal Shape

Code	Terminal Shape
C	Connector Type

④ Electrical Effective Rotational Angle

Expressed by three figures. The unit is degree. The first and second figures are significant digits, and the third figure expresses the number of zeros which follow the two figures.

Ex.)

Code	Electrical Effective Rotational Angle
201	200°

⑤ Shaft Shape/Shaft Size

Code	Shaft Shape/Shaft Size
BJ	D Shaft/6.0mm Dia.

⑥ Individual Specification Code

Code	Individual Specification Code
A01	Connector Type Standard

⑦ Packaging

Code	Packaging
B00	Bulk

Selection Guide of Trimmer Potentiometers

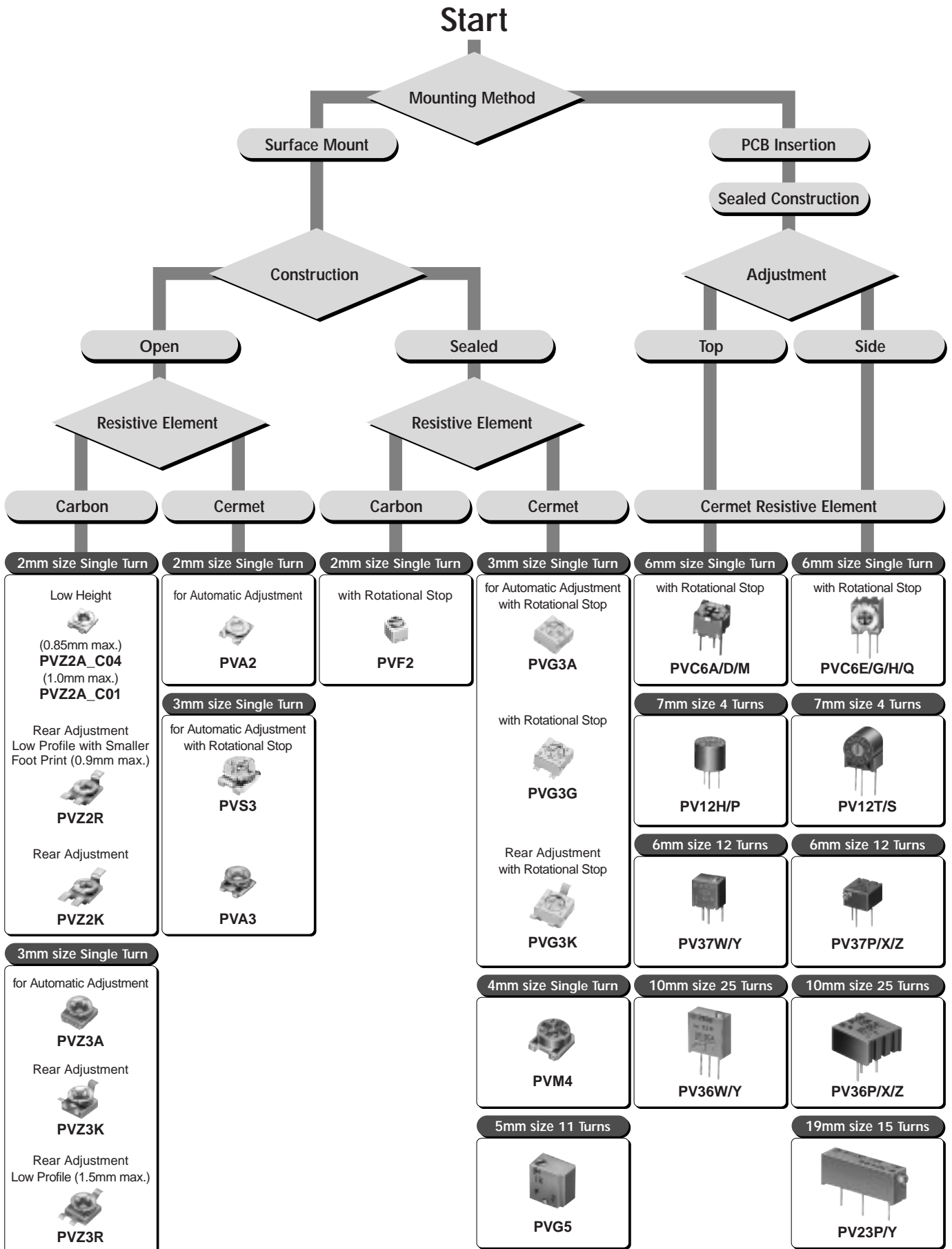

Trimmer Potentiometers



SMD Open Type 2mm Size PVZ2/PVA2 Series

PVZ2 Series

■ Features

1. Ultra-small and thin external dimensions of 2.1(W)x2.7(L)x0.85 max. (T)mm.
(Top adjustment type: PVZ2A_A04/C04 Series)
2. Ultra-small and thin external dimensions of 2.1(W)x4.8(L)x0.9 max. (T)mm.
(Rear adjustment type: PVZ2R_C04 Series)
Compact PCB design is possible by smaller a djustment hole (3.0mm dia.) due to short wing length (4.8mm).
3. Au plated termination achieves a high density PCB mounting.
4. Cross-shaped driver slot allows for in-process automatic adjustment and it provides superior adjustability.
5. Two-piece parts construction achieves low cost and excellent quality.
6. Special resin substrate allows high peak temperature for reflow soldering. (PVZ2_Cxx Series)

■ Applications

1. Pick-up module
2. LCD
3. Cellular-phone
4. PHS
5. Pager
6. DVC
7. Digital camera
8. Portable audio, etc.



PVZ2A

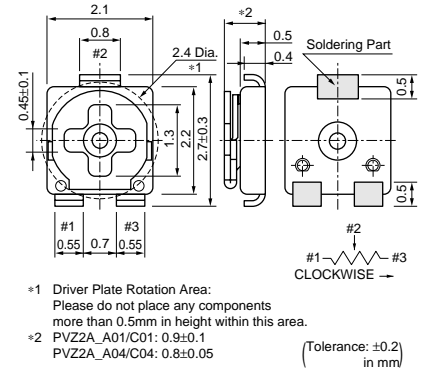

PVZ2K

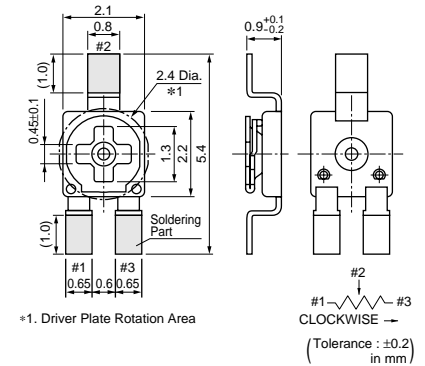

PVZ2R

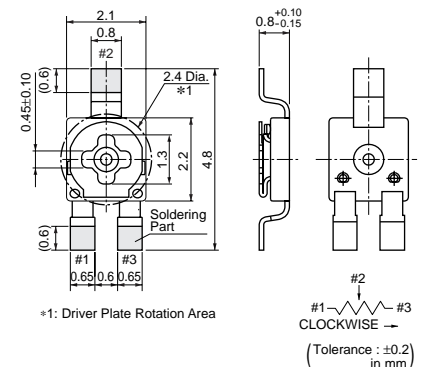

Part Number	Power Rating (W)	Soldering Method	Number of Turns (Effective Rotation Angle)	Total Resistance Value	TCR (ppm/°C)
PVZ2□501C01	0.1(50°C)	Reflow/Soldering Iron	1(240°±10°)	500ohm ±30%	±500
PVZ2□102C01	0.1(50°C)	Reflow/Soldering Iron	1(240°±10°)	1k ohm ±30%	±500
PVZ2□202C01	0.1(50°C)	Reflow/Soldering Iron	1(240°±10°)	2k ohm ±30%	±500
PVZ2□302C01	0.1(50°C)	Reflow/Soldering Iron	1(240°±10°)	3k ohm ±30%	±500
PVZ2□502C01	0.1(50°C)	Reflow/Soldering Iron	1(240°±10°)	5k ohm ±30%	±500
PVZ2□103C01	0.1(50°C)	Reflow/Soldering Iron	1(240°±10°)	10k ohm ±30%	±500
PVZ2□203C01	0.1(50°C)	Reflow/Soldering Iron	1(240°±10°)	20k ohm ±30%	±500
PVZ2□303C01	0.1(50°C)	Reflow/Soldering Iron	1(240°±10°)	30k ohm ±30%	±500
PVZ2□503C01	0.1(50°C)	Reflow/Soldering Iron	1(240°±10°)	50k ohm ±30%	±500
PVZ2□104C01	0.1(50°C)	Reflow/Soldering Iron	1(240°±10°)	100k ohm ±30%	±500

Continued on the following page.

Continued from the preceding page.

Part Number	Power Rating (W)	Soldering Method	Number of Turns (Effective Rotation Angle)	Total Resistance Value	TCR (ppm/°C)
PVZ2□204C01	0.1(50°C)	Reflow/Soldering Iron	1(240°±10°)	200k ohm ±30%	±500
PVZ2□304C01	0.1(50°C)	Reflow/Soldering Iron	1(240°±10°)	300k ohm ±30%	±500
PVZ2□504C01	0.1(50°C)	Reflow/Soldering Iron	1(240°±10°)	500k ohm ±30%	±500
PVZ2□501C04	0.1(50°C)	Reflow/Soldering Iron	1(240°±10°)	500ohm ±30%	±500
PVZ2□102C04	0.1(50°C)	Reflow/Soldering Iron	1(240°±10°)	1k ohm ±30%	±500
PVZ2□202C04	0.1(50°C)	Reflow/Soldering Iron	1(240°±10°)	2k ohm ±30%	±500
PVZ2□302C04	0.1(50°C)	Reflow/Soldering Iron	1(240°±10°)	3k ohm ±30%	±500
PVZ2□502C04	0.1(50°C)	Reflow/Soldering Iron	1(240°±10°)	5k ohm ±30%	±500
PVZ2□103C04	0.1(50°C)	Reflow/Soldering Iron	1(240°±10°)	10k ohm ±30%	±500
PVZ2□203C04	0.1(50°C)	Reflow/Soldering Iron	1(240°±10°)	20k ohm ±30%	±500
PVZ2□303C04	0.1(50°C)	Reflow/Soldering Iron	1(240°±10°)	30k ohm ±30%	±500
PVZ2□503C04	0.1(50°C)	Reflow/Soldering Iron	1(240°±10°)	50k ohm ±30%	±500
PVZ2□104C04	0.1(50°C)	Reflow/Soldering Iron	1(240°±10°)	100k ohm ±30%	±500
PVZ2□204C04	0.1(50°C)	Reflow/Soldering Iron	1(240°±10°)	200k ohm ±30%	±500
PVZ2□304C04	0.1(50°C)	Reflow/Soldering Iron	1(240°±10°)	300k ohm ±30%	±500
PVZ2□504C04	0.1(50°C)	Reflow/Soldering Iron	1(240°±10°)	500k ohm ±30%	±500
PVZ2□105C04	0.1(50°C)	Reflow/Soldering Iron	1(240°±10°)	1M ohm ±30%	±500

Operating Temperature Range: -25 to 85 °C

The blank column is filled with the code of adjustment direction and lead type A (top), K (rear) or R (rear). R is only for C04.

Construction

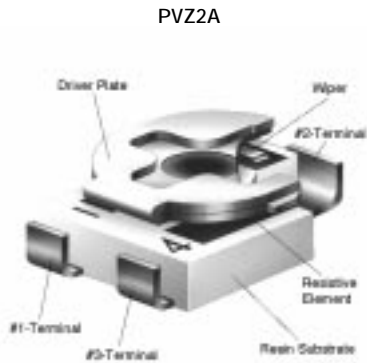

Standard Land Pattern

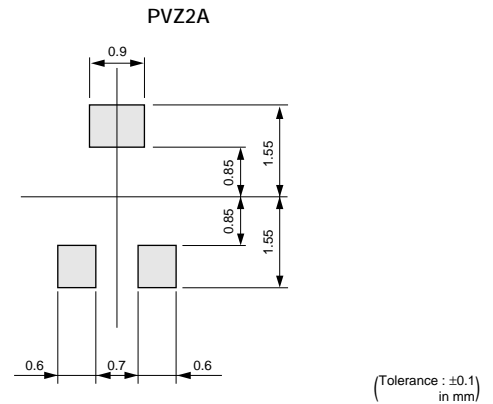

Construction

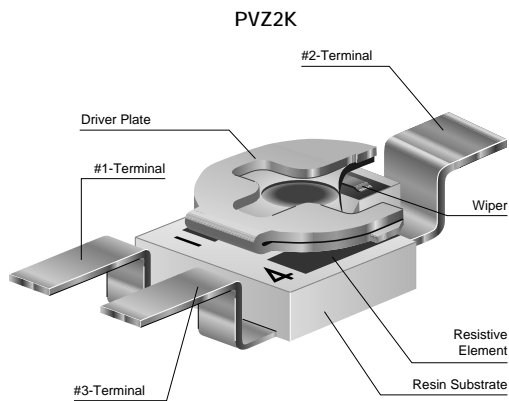

Standard Land Pattern

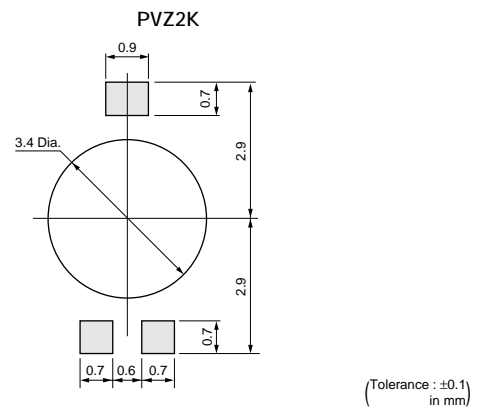

Continued on the following page.

Continued from the preceding page.

Construction

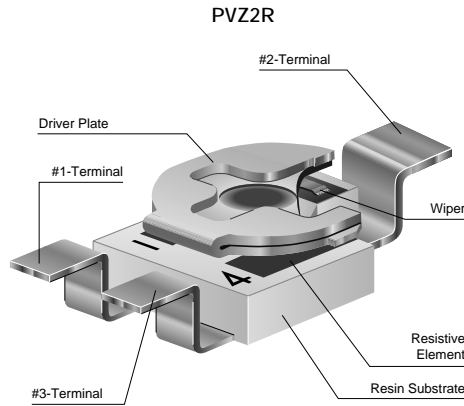

Standard Land Pattern

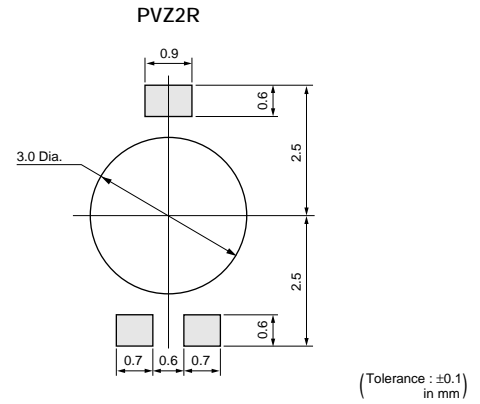

Characteristics

Humidity Exposure	Res. Change : +10, -2%
High Temperature Exposure	Res. Change : $R \leq 50\text{kohm} \dots +2, -10\%$ $50\text{kohm} < R \dots +2, -15\%$
Humidity Load Life	Res. Change : ±10%
Load Life	Res. Change : $R \leq 50\text{kohm} \dots +2, -10\%$ $50\text{kohm} < R \dots +2, -15\%$
Temperature Cycle	Res. Change : ±5%
Temperature Coefficient of Resistance	±500ppm/°C
Rotational Life	Res. Change : ±10% (10 cycles)

PVA2 Series

Features

1. Ultra-small and thin external dimensions of 2.2(W)x2.75(L)x0.90 max.(T)mm.
2. For the terminal attachment method of construction which uses neither solder nor adhesives, good solderability and terminal attachment intensity are realized.
3. Because of multi-contact wiper structure, PVA2 have a stable characteristics (low noise).
4. PVA2 series don't use a solder, flux and cleaning solvent, so they are environmentally friendly products.
5. Heat resistance performance enables high temperature peak re-flow soldering.
6. PVA2 series comply with RoHS directive.

Applications

1. Thin-model optical pick-up module
2. LCD module
3. Optical communication module
4. Small sensor module
5. Digital camera
6. Small telecommunication equipment, etc.

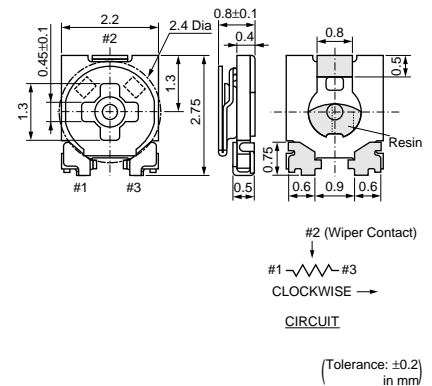

Part Number	Power Rating (W)	Soldering Method	Number of Turns (Effective Rotation Angle)	Total Resistance Value	TCR (ppm/°C)
PVA2A101A01	0.1(70°C)	Reflow/Soldering Iron	1(260°±10°)	100ohm ±25%	±250
PVA2A151A01	0.1(70°C)	Reflow/Soldering Iron	1(260°±10°)	150ohm ±25%	±250
PVA2A221A01	0.1(70°C)	Reflow/Soldering Iron	1(260°±10°)	220ohm ±25%	±250
PVA2A331A01	0.1(70°C)	Reflow/Soldering Iron	1(260°±10°)	330ohm ±25%	±250

Continued on the following page.

Continued from the preceding page.

Part Number	Power Rating (W)	Soldering Method	Number of Turns (Effective Rotation Angle)	Total Resistance Value	TCR (ppm/°C)
PVA2A471A01	0.1(70°C)	Reflow/Soldering Iron	1(260°±10°)	470ohm ±25%	±250
PVA2A681A01	0.1(70°C)	Reflow/Soldering Iron	1(260°±10°)	680ohm ±25%	±250
PVA2A102A01	0.1(70°C)	Reflow/Soldering Iron	1(260°±10°)	1k ohm ±25%	±250
PVA2A152A01	0.1(70°C)	Reflow/Soldering Iron	1(260°±10°)	1.5k ohm ±25%	±250
PVA2A222A01	0.1(70°C)	Reflow/Soldering Iron	1(260°±10°)	2.2k ohm ±25%	±250
PVA2A332A01	0.1(70°C)	Reflow/Soldering Iron	1(260°±10°)	3.3k ohm ±25%	±250
PVA2A472A01	0.1(70°C)	Reflow/Soldering Iron	1(260°±10°)	4.7k ohm ±25%	±250
PVA2A682A01	0.1(70°C)	Reflow/Soldering Iron	1(260°±10°)	6.8k ohm ±25%	±250
PVA2A103A01	0.1(70°C)	Reflow/Soldering Iron	1(260°±10°)	10k ohm ±25%	±250
PVA2A153A01	0.1(70°C)	Reflow/Soldering Iron	1(260°±10°)	15k ohm ±25%	±250
PVA2A223A01	0.1(70°C)	Reflow/Soldering Iron	1(260°±10°)	22k ohm ±25%	±250
PVA2A333A01	0.1(70°C)	Reflow/Soldering Iron	1(260°±10°)	33k ohm ±25%	±250
PVA2A473A01	0.1(70°C)	Reflow/Soldering Iron	1(260°±10°)	47k ohm ±25%	±250
PVA2A683A01	0.1(70°C)	Reflow/Soldering Iron	1(260°±10°)	68k ohm ±25%	±250
PVA2A104A01	0.1(70°C)	Reflow/Soldering Iron	1(260°±10°)	100k ohm ±25%	±250
PVA2A154A01	0.1(70°C)	Reflow/Soldering Iron	1(260°±10°)	150k ohm ±25%	±250
PVA2A224A01	0.1(70°C)	Reflow/Soldering Iron	1(260°±10°)	220k ohm ±25%	±250
PVA2A334A01	0.1(70°C)	Reflow/Soldering Iron	1(260°±10°)	330k ohm ±25%	±250
PVA2A474A01	0.1(70°C)	Reflow/Soldering Iron	1(260°±10°)	470k ohm ±25%	±250
PVA2A684A01	0.1(70°C)	Reflow/Soldering Iron	1(260°±10°)	680k ohm ±25%	±250
PVA2A105A01	0.1(70°C)	Reflow/Soldering Iron	1(260°±10°)	1M ohm ±25%	±250
PVA2A155A01	0.1(70°C)	Reflow/Soldering Iron	1(260°±10°)	1.5M ohm ±25%	±250
PVA2A225A01	0.1(70°C)	Reflow/Soldering Iron	1(260°±10°)	2.2M ohm ±25%	±250

Operating Temperature Range: -55 to 125 °C

Construction

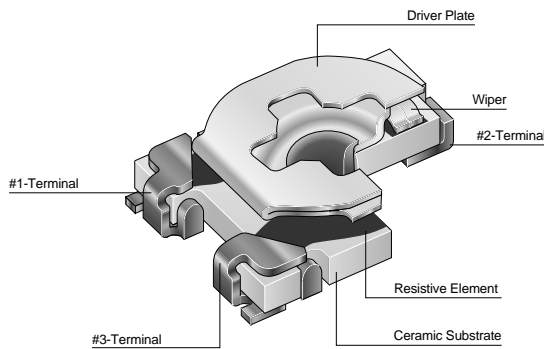

Standard Land Pattern

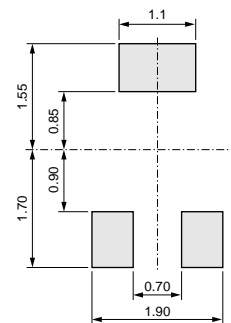

(Tolerance : ±0.1 in mm)

Characteristics

Humidity Exposure	Res. Change : ±3%
High Temperature Exposure	Res. Change : ±3%
Humidity Load Life	Res. Change : ±3%
Load Life	Res. Change : ±3%
Temperature Cycle	Res. Change : ±3%
Temperature Coefficient of Resistance	±250ppm/°C
Rotational Life	Res. Change : ±10% (10 cycles)

PVZ2/PVA2 Series Notice

■ Notice (Operating and Storage Conditions)

1. Store in temperatures of -10 to +40 deg. C and relative humidity of 30-85%RH.
2. Do not store in or near corrosive gases.
3. Use within six months after delivery.
4. Open the package just before using.
5. Do not store under direct sunlight.
6. If you use the trimmer potentiometer in an environment other than listed below, please consult with a Murata factory representative prior to using.

The trimmer potentiometer should not be used under the following environmental conditions:

- (1) Corrosive gaseous atmosphere
(Ex. Chlorine gas, Hydrogen sulfide gas, Ammonia gas, Sulfuric acid gas, Nitric oxide gas, etc.)
- (2) In liquid
(Ex. Oil, Medical liquid, Organic solvent, etc.)
- (3) Dusty/dirty atmosphere
- (4) Direct sunlight
- (5) Static voltage nor electric/magnetic fields
- (6) Direct sea breeze
- (7) Other variations of the above

■ Notice (Rating)

1. When using with partial load (rheostat), minimize the power depending on the resistance value.
2. The maximum input voltage to a trimmer potentiometer should not exceed $(P \cdot R)^{1/2}$ or the maximum operating voltage, whichever is smaller.
3. If the trimmer potentiometer is used in DC and high humidity conditions, please connect wiper (#2) for plus and resistive element (#1 or #3) for minus.
(PVZ Series only)

■ Notice (Soldering and Mounting)

1. Soldering
 - (1) Reflow soldering method and soldering iron are available. Cannot be soldered using the flow soldering method (dipping). If you use the flow soldering method, the trimmer potentiometer may not function.
 - (2) Use our standard land dimension. Excessive land area causes displacement due to the effect of the surface tension of the solder. Insufficient land area leads to insufficient soldering strength of the chip.
 - (3) Soldering condition
Refer to the temperature profile.
If the soldering conditions are not suitable, e.g., excessive time and/or excessive temperature, the trimmer potentiometer may deviate from the specified characteristics.
 - (4) Apply the appropriate amount of solder paste.
The thickness of solder paste should be printed from 100 micro m to 150 micro m and the dimension of land pattern used should be Murata's standard land pattern at reflow soldering. Insufficient amounts of solder can lead to insufficient soldering strength on PCB.

Excessive amounts of solder may cause bridging between the terminals.

- (5) The soldering iron should not come in contact with the case of the trimmer potentiometer. If such contact does occur, the trimmer potentiometer may be damaged.

2. Mounting

- (1) Do not apply excessive force (preferably 4.9N (Ref.; 500gf) max.), when the trimmer potentiometer is mounted to the PCB.
- (2) Do not warp and/or bend PC board to prevent trimmer potentiometer from breakage.
- (3) In chip placers, the recommended size of the cylindrical pick-up nozzle should be outer dimension 1.5-1.8mm dia. and inner dimension 1.3mm dia.

3. Cleaning

- (1) In case there is flux on the resistive element, clean sufficiently with cleaning solvents and completely remove all residual flux.
- (2) Isopropyl-alcohol and Ethyl-alcohol are applicable solvents for cleaning. If you use any other types of solvents, please evaluate performance by your product.

PVZ2/PVA2 Series Notice

■ Soldering Profile

● Reflow Soldering Profile

1. Soldering profile for Lead-free solder (96.5Sn/3.0Ag/0.5Cu)

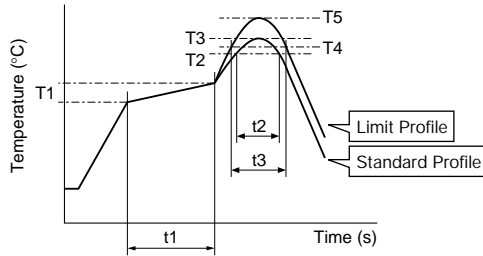

Series	Standard Profile						Limit Profile					
	Pre-heating		Heating		Peak Temperature (T3)	Cycle of Reflow	Pre-heating		Heating		Peak Temperature (T5)	Cycle of Reflow
	Temp. (T1)	Time (t1)	Temp. (T2)	Time (t2)			Temp. (T1)	Time (t1)	Temp. (T4)	Time (t3)		
°C	sec.	°C	sec.	°C	Time	°C	sec.	°C	sec.	°C	Time	
PVA2	150 to 180	60 to 120	220	30 to 60	245±3	2	150 to 180	60 to 120	220	30 to 60	260 +5/-0	2
PVZ2****A**	130 to 160	60 to 120	200	20 to 50	245±3	2	130 to 160	60 to 120	200	20 to 50	250	2
PVZ2****C**	150 to 180	60 to 120	220	30 to 60	245±3	2	150 to 180	60 to 120	220	30 to 60	260	2

2. Soldering profile for Eutectic solder (63Sn/37Pb)

(Limit profile: refer to 1)

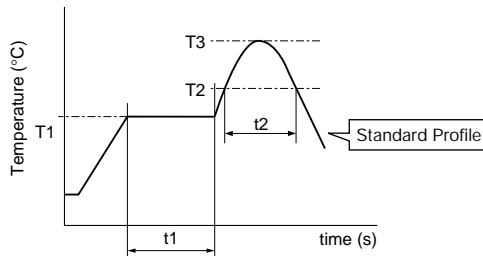

Series	Standard Profile					
	Pre-heating		Heating		Peak Temperature (T3)	Cycle of Reflow
	Temp. (T1)	Time (t1)	Temp. (T2)	Time (t2)		
°C	sec.	°C	sec.	°C	Time	
PVA2 PVZ2****A** PVZ2****C**	150	60 to 120	183	30	230	1

● Soldering Iron

Series	Standard Condition			
	Temperature of Soldering Iron Tip	Soldering Time	Soldering Iron Power Output	Cycle of Soldering Iron
	°C	sec.	W	Time
PVA2 PVZ2****A** PVZ2****C**	350±10	3 max.	30 max.	1

■ Notice (Handling)

- Use suitable screwdrivers that fit comfortably in driver slot. We recommend the screwdriver below.
* Recommended screwdriver for manual adjustment
Murata P/N: KMDR190
- Don't apply more than 4.9N (Ref.; 500gf) of twist and stress after mounting onto PCB to prevent contact intermittence. If excessive force is applied, the trimmer potentiometer may not function.
- Please use within the effective rotational angle.
The trimmer potentiometer does not have a mechanical stop for over rotation. In cases out of effective rotational angle, the trimmer potentiometer may not function.
- When using a lock paint to fix slot position or cover the rotor, please evaluate performance by your product. Lock paint may cause corrosion or electrical contact problems.

■ Notice (Other)

- Please make sure that your product has been evaluated and confirmed against your specifications when our product is mounted to your product.
- Murata cannot guarantee trimmer potentiometer integrity when used under conditions other than those specified in this document.

Trimmer Potentiometers



SMD Open Type 3mm Size PVZ3/PVS3/PVA3 Series

2

PVZ3 Series

■ Features

1. Excellent solderability characteristics are achieved via special plating techniques on each termination.
2. Specially designed substrate prevents wicking of flux onto the top of the part body.
3. Funnel shaped adjustment slot allows for in-process automatic adjustment.
4. High-heat resistance type is available (PVZ3A_C01/PVZ3K_E01/PVZ3R_E01).
5. Enlarged bottom termination enhance soldering strength while reducing the necessary land area required promoting high-density PCB mounting.
6. Flat surface is provided for smooth pick and place. (for PVZ3K Series)
7. Low profile rear adjustment type (PVZ3R Series) realizes 1.5mm max. height by infilling driver plate into through-hole of PCB.
8. The standard position of driver plate is adjusted at the center normally, but another position is also available.
9. This product meets Pb-free.

■ Applications

1. Optical pick up
2. Cordless telephones
3. CD players
4. FDD
5. Motor
6. CD-ROMs
7. Car stereos
8. TFT-LCD TV sets
9. Headphone stereos



PVZ3A

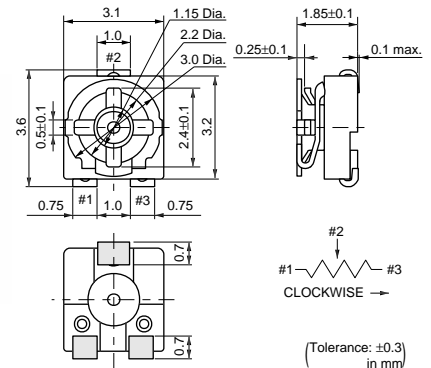

PVZ3K

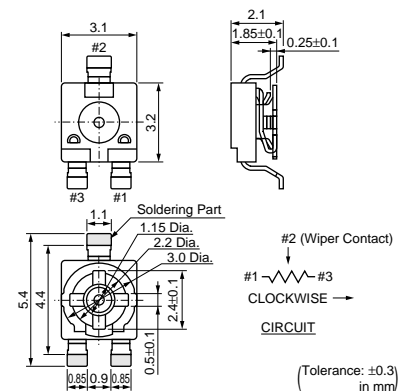

PVZ3R

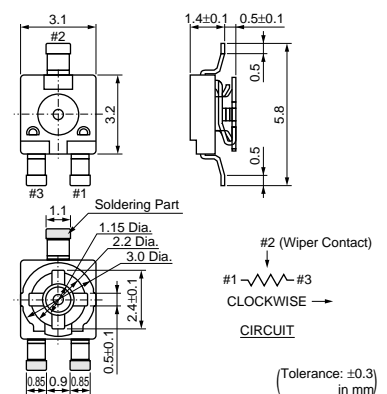

Part Number	Power Rating (W)	Soldering Method	Number of Turns (Effective Rotation Angle)	Total Resistance Value	TCR (ppm/°C)
PVZ3A201□	0.1(50°C)	Reflow/Soldering Iron	1(230°±10°)	200ohm ±30%	±500
PVZ3A301□	0.1(50°C)	Reflow/Soldering Iron	1(230°±10°)	300ohm ±30%	±500
PVZ3A501□	0.1(50°C)	Reflow/Soldering Iron	1(230°±10°)	500ohm ±30%	±500
PVZ3A102□	0.1(50°C)	Reflow/Soldering Iron	1(230°±10°)	1k ohm ±30%	±500
PVZ3A202□	0.1(50°C)	Reflow/Soldering Iron	1(230°±10°)	2k ohm ±30%	±500
PVZ3A302□	0.1(50°C)	Reflow/Soldering Iron	1(230°±10°)	3k ohm ±30%	±500
PVZ3A502□	0.1(50°C)	Reflow/Soldering Iron	1(230°±10°)	5k ohm ±30%	±500
PVZ3A103□	0.1(50°C)	Reflow/Soldering Iron	1(230°±10°)	10k ohm ±30%	±500
PVZ3A203□	0.1(50°C)	Reflow/Soldering Iron	1(230°±10°)	20k ohm ±30%	±500
PVZ3A303□	0.1(50°C)	Reflow/Soldering Iron	1(230°±10°)	30k ohm ±30%	±500

Continued on the following page. ↗

 Continued from the preceding page.

Part Number	Power Rating (W)	Soldering Method	Number of Turns (Effective Rotation Angle)	Total Resistance Value	TCR (ppm/°C)
PVZ3A503□	0.1(50°C)	Reflow/Soldering Iron	1(230°±10°)	50k ohm ±30%	±500
PVZ3A104□	0.1(50°C)	Reflow/Soldering Iron	1(230°±10°)	100k ohm ±30%	±500
PVZ3A204□	0.1(50°C)	Reflow/Soldering Iron	1(230°±10°)	200k ohm ±30%	±500
PVZ3A304□	0.1(50°C)	Reflow/Soldering Iron	1(230°±10°)	300k ohm ±30%	±500
PVZ3A504□	0.1(50°C)	Reflow/Soldering Iron	1(230°±10°)	500k ohm ±30%	±500
PVZ3A105□	0.1(50°C)	Reflow/Soldering Iron	1(230°±10°)	1M ohm ±30%	±500
PVZ3A205□	0.1(50°C)	Reflow/Soldering Iron	1(230°±10°)	2M ohm ±30%	±500
PVZ3K201E01	0.1(50°C)	Reflow/Soldering Iron	1(230°±10°)	200ohm ±30%	±500
PVZ3K301E01	0.1(50°C)	Reflow/Soldering Iron	1(230°±10°)	300ohm ±30%	±500
PVZ3K501E01	0.1(50°C)	Reflow/Soldering Iron	1(230°±10°)	500ohm ±30%	±500
PVZ3K102E01	0.1(50°C)	Reflow/Soldering Iron	1(230°±10°)	1k ohm ±30%	±500
PVZ3K202E01	0.1(50°C)	Reflow/Soldering Iron	1(230°±10°)	2k ohm ±30%	±500
PVZ3K302E01	0.1(50°C)	Reflow/Soldering Iron	1(230°±10°)	3k ohm ±30%	±500
PVZ3K502E01	0.1(50°C)	Reflow/Soldering Iron	1(230°±10°)	5k ohm ±30%	±500
PVZ3K103E01	0.1(50°C)	Reflow/Soldering Iron	1(230°±10°)	10k ohm ±30%	±500
PVZ3K203E01	0.1(50°C)	Reflow/Soldering Iron	1(230°±10°)	20k ohm ±30%	±500
PVZ3K303E01	0.1(50°C)	Reflow/Soldering Iron	1(230°±10°)	30k ohm ±30%	±500
PVZ3K503E01	0.1(50°C)	Reflow/Soldering Iron	1(230°±10°)	50k ohm ±30%	±500
PVZ3K104E01	0.1(50°C)	Reflow/Soldering Iron	1(230°±10°)	100k ohm ±30%	±500
PVZ3K204E01	0.1(50°C)	Reflow/Soldering Iron	1(230°±10°)	200k ohm ±30%	±500
PVZ3K304E01	0.1(50°C)	Reflow/Soldering Iron	1(230°±10°)	300k ohm ±30%	±500
PVZ3K504E01	0.1(50°C)	Reflow/Soldering Iron	1(230°±10°)	500k ohm ±30%	±500
PVZ3K105E01	0.1(50°C)	Reflow/Soldering Iron	1(230°±10°)	1M ohm ±30%	±500
PVZ3K205E01	0.1(50°C)	Reflow/Soldering Iron	1(230°±10°)	2M ohm ±30%	±500
PVZ3R201E01	0.1(50°C)	Reflow/Soldering Iron	1(230°±10°)	200ohm ±30%	±500
PVZ3R301E01	0.1(50°C)	Reflow/Soldering Iron	1(230°±10°)	300ohm ±30%	±500
PVZ3R501E01	0.1(50°C)	Reflow/Soldering Iron	1(230°±10°)	500ohm ±30%	±500
PVZ3R102E01	0.1(50°C)	Reflow/Soldering Iron	1(230°±10°)	1k ohm ±30%	±500
PVZ3R202E01	0.1(50°C)	Reflow/Soldering Iron	1(230°±10°)	2k ohm ±30%	±500
PVZ3R302E01	0.1(50°C)	Reflow/Soldering Iron	1(230°±10°)	3k ohm ±30%	±500
PVZ3R502E01	0.1(50°C)	Reflow/Soldering Iron	1(230°±10°)	5k ohm ±30%	±500
PVZ3R103E01	0.1(50°C)	Reflow/Soldering Iron	1(230°±10°)	10k ohm ±30%	±500
PVZ3R203E01	0.1(50°C)	Reflow/Soldering Iron	1(230°±10°)	20k ohm ±30%	±500
PVZ3R303E01	0.1(50°C)	Reflow/Soldering Iron	1(230°±10°)	30k ohm ±30%	±500
PVZ3R503E01	0.1(50°C)	Reflow/Soldering Iron	1(230°±10°)	50k ohm ±30%	±500
PVZ3R104E01	0.1(50°C)	Reflow/Soldering Iron	1(230°±10°)	100k ohm ±30%	±500
PVZ3R204E01	0.1(50°C)	Reflow/Soldering Iron	1(230°±10°)	200k ohm ±30%	±500
PVZ3R304E01	0.1(50°C)	Reflow/Soldering Iron	1(230°±10°)	300k ohm ±30%	±500
PVZ3R504E01	0.1(50°C)	Reflow/Soldering Iron	1(230°±10°)	500k ohm ±30%	±500
PVZ3R105E01	0.1(50°C)	Reflow/Soldering Iron	1(230°±10°)	1M ohm ±30%	±500
PVZ3R205E01	0.1(50°C)	Reflow/Soldering Iron	1(230°±10°)	2M ohm ±30%	±500

Operating Temperature Range: -25 to 85 °C

The blank column is filled with the code of individual specification A01 (standard type) and C01 (high-heat resistance type).

2

■ Construction

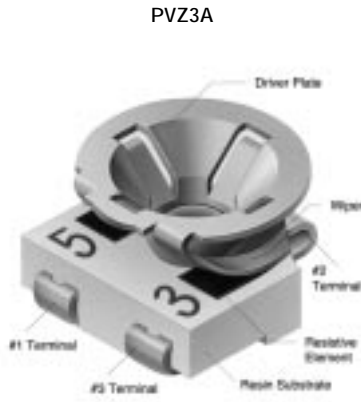

■ Standard Land Pattern

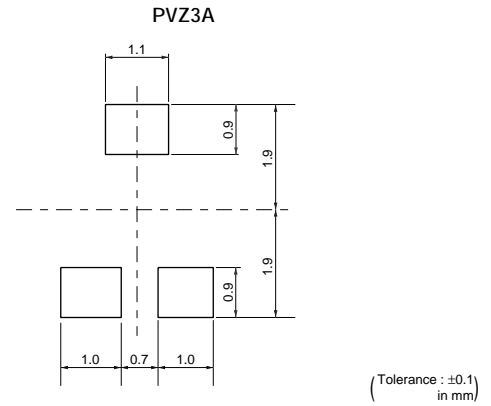

■ Construction

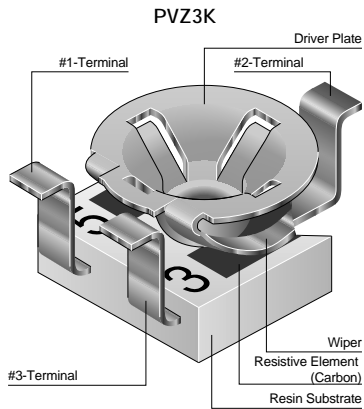

■ Standard Land Pattern

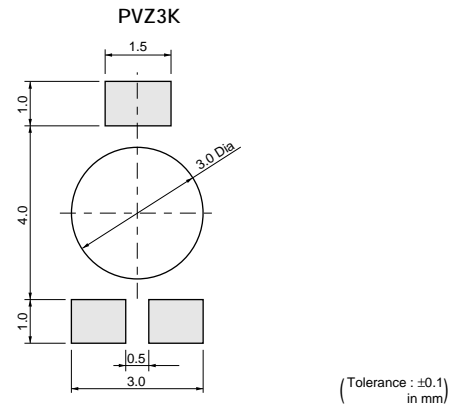

■ Construction

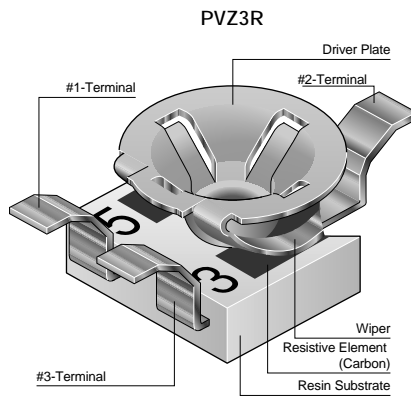

■ Standard Land Pattern

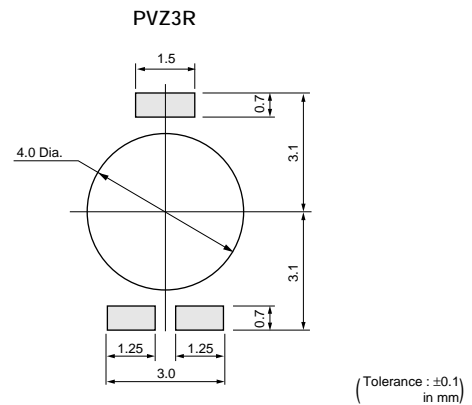

■ Characteristics

Humidity Exposure	Res. Change : +10, -2%
High Temperature Exposure	Res. Change : $R \leq 100\text{kohm} \dots +2, -10\%$ $100\text{kohm} < R \dots +2, -15\%$
Humidity Load Life	Res. Change : $\pm 10\%$
Load Life	Res. Change : $R \leq 100\text{kohm} \dots +2, -10\%$ $100\text{kohm} < R \dots +2, -15\%$
Temperature Cycle	Res. Change : $\pm 5\%$
Temperature Coefficient of Resistance	$\pm 500\text{ppm}/^\circ\text{C}$
Rotational Life	Res. Change : $\pm 10\%$ (10 cycles)

PVS3 Series

■ Features

1. Funnel shaped slot allows for in-process automatic adjustment and it provides superior adjustability.
2. Easy insertion and operation of adjustment screwdriver.
3. Low profile of 1.5mm height with stopper.
4. Plated termination achieves high resistance to solder leaching.
5. Screwdrivers for adjustment are available on the market.

■ Applications

1. Camcorders
2. Video disk players
3. TFT-LCD TV sets
4. Headphone stereos
5. Cordless telephones
6. Micro-motors
7. Optical cameras

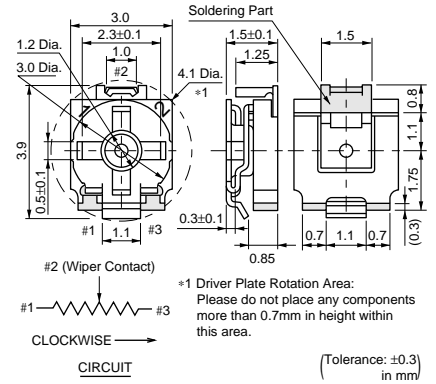

Part Number	Power Rating (W)	Soldering Method	Number of Turns (Effective Rotation Angle)	Total Resistance Value	TCR (ppm/°C)
PVS3A101A01	0.1(70°C)	Reflow/Soldering Iron	1(270°±10°)	100ohm ±25%	±250
PVS3A201A01	0.1(70°C)	Reflow/Soldering Iron	1(270°±10°)	200ohm ±25%	±250
PVS3A301A01	0.1(70°C)	Reflow/Soldering Iron	1(270°±10°)	300ohm ±25%	±250
PVS3A501A01	0.1(70°C)	Reflow/Soldering Iron	1(270°±10°)	500ohm ±25%	±250
PVS3A102A01	0.1(70°C)	Reflow/Soldering Iron	1(270°±10°)	1k ohm ±25%	±250
PVS3A202A01	0.1(70°C)	Reflow/Soldering Iron	1(270°±10°)	2k ohm ±25%	±250
PVS3A302A01	0.1(70°C)	Reflow/Soldering Iron	1(270°±10°)	3k ohm ±25%	±250
PVS3A502A01	0.1(70°C)	Reflow/Soldering Iron	1(270°±10°)	5k ohm ±25%	±250
PVS3A103A01	0.1(70°C)	Reflow/Soldering Iron	1(270°±10°)	10k ohm ±25%	±250
PVS3A203A01	0.1(70°C)	Reflow/Soldering Iron	1(270°±10°)	20k ohm ±25%	±250
PVS3A303A01	0.1(70°C)	Reflow/Soldering Iron	1(270°±10°)	30k ohm ±25%	±250
PVS3A503A01	0.1(70°C)	Reflow/Soldering Iron	1(270°±10°)	50k ohm ±25%	±250
PVS3A104A01	0.1(70°C)	Reflow/Soldering Iron	1(270°±10°)	100k ohm ±25%	±250
PVS3A204A01	0.1(70°C)	Reflow/Soldering Iron	1(270°±10°)	200k ohm ±25%	±250
PVS3A304A01	0.1(70°C)	Reflow/Soldering Iron	1(270°±10°)	300k ohm ±25%	±250
PVS3A504A01	0.1(70°C)	Reflow/Soldering Iron	1(270°±10°)	500k ohm ±25%	±250
PVS3A105A01	0.1(70°C)	Reflow/Soldering Iron	1(270°±10°)	1M ohm ±25%	±250
PVS3A205A01	0.1(70°C)	Reflow/Soldering Iron	1(270°±10°)	2M ohm ±25%	±250

Operating Temperature Range: -55 to 125 °C

■ Construction

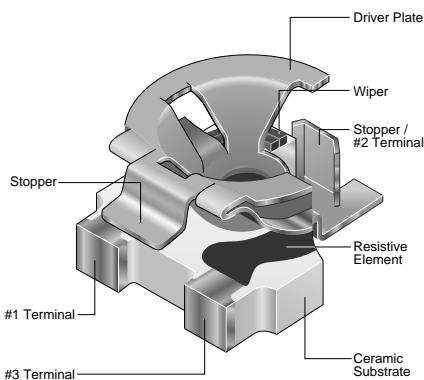

■ Standard Land Pattern

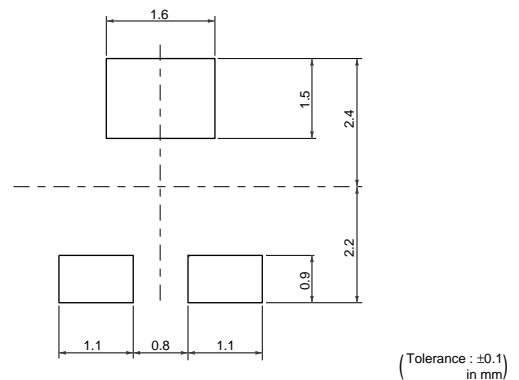

Continued on the following page.

 Continued from the preceding page.

■ Characteristics

Humidity Exposure	Res. Change : $\pm 3\%$
High Temperature Exposure	Res. Change : $\pm 3\%$
Humidity Load Life	Res. Change : $\pm 3\%$
Load Life	Res. Change : $\pm 3\%$
Temperature Cycle	Res. Change : $\pm 3\%$
Temperature Coefficient of Resistance	$\pm 250\text{ppm}/^{\circ}\text{C}$
Rotational Life	Res. Change : $\pm 10\%$ (10 cycles)

PVA3 Series

■ Features

1. Funnel shaped slot allows for in-process automatic adjustment and it provides superior adjustability.
2. Easy insertion and operation of adjustment screwdriver.
3. Plated termination achieves high resistance to solder leaching.
4. Screwdrivers for adjustment are available on the market.
5. Recommended for both reflow and flow soldering method. (Need cleaning for flow soldering method)

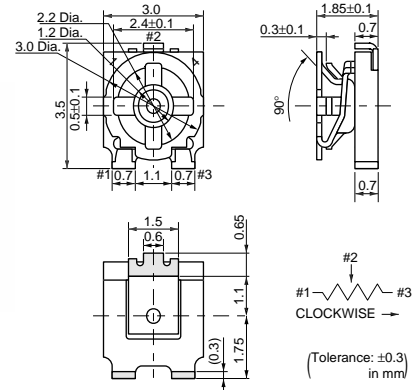

■ Applications

1. Camcorders
2. Video disk players
3. TFT-LCD TV sets
4. Headphone stereos
5. Cordless telephones
6. Micro-motors
7. Optical cameras

Part Number	Power Rating (W)	Soldering Method	Number of Turns (Effective Rotation Angle)	Total Resistance Value	TCR (ppm/°C)
PVA3A101A01	0.1(70°C)	Flow/Reflow/Soldering Iron	1(270°±10°)	100ohm ±25%	±250
PVA3A201A01	0.1(70°C)	Flow/Reflow/Soldering Iron	1(270°±10°)	200ohm ±25%	±250
PVA3A301A01	0.1(70°C)	Flow/Reflow/Soldering Iron	1(270°±10°)	300ohm ±25%	±250
PVA3A501A01	0.1(70°C)	Flow/Reflow/Soldering Iron	1(270°±10°)	500ohm ±25%	±250
PVA3A102A01	0.1(70°C)	Flow/Reflow/Soldering Iron	1(270°±10°)	1k ohm ±25%	±250
PVA3A202A01	0.1(70°C)	Flow/Reflow/Soldering Iron	1(270°±10°)	2k ohm ±25%	±250
PVA3A302A01	0.1(70°C)	Flow/Reflow/Soldering Iron	1(270°±10°)	3k ohm ±25%	±250
PVA3A502A01	0.1(70°C)	Flow/Reflow/Soldering Iron	1(270°±10°)	5k ohm ±25%	±250
PVA3A103A01	0.1(70°C)	Flow/Reflow/Soldering Iron	1(270°±10°)	10k ohm ±25%	±250
PVA3A203A01	0.1(70°C)	Flow/Reflow/Soldering Iron	1(270°±10°)	20k ohm ±25%	±250
PVA3A303A01	0.1(70°C)	Flow/Reflow/Soldering Iron	1(270°±10°)	30k ohm ±25%	±250
PVA3A503A01	0.1(70°C)	Flow/Reflow/Soldering Iron	1(270°±10°)	50k ohm ±25%	±250
PVA3A104A01	0.1(70°C)	Flow/Reflow/Soldering Iron	1(270°±10°)	100k ohm ±25%	±250
PVA3A204A01	0.1(70°C)	Flow/Reflow/Soldering Iron	1(270°±10°)	200k ohm ±25%	±250
PVA3A304A01	0.1(70°C)	Flow/Reflow/Soldering Iron	1(270°±10°)	300k ohm ±25%	±250
PVA3A504A01	0.1(70°C)	Flow/Reflow/Soldering Iron	1(270°±10°)	500k ohm ±25%	±250
PVA3A105A01	0.1(70°C)	Flow/Reflow/Soldering Iron	1(270°±10°)	1M ohm ±25%	±250
PVA3A205A01	0.1(70°C)	Flow/Reflow/Soldering Iron	1(270°±10°)	2M ohm ±25%	±250

Operating Temperature Range: -55 to 125 °C

■ Construction

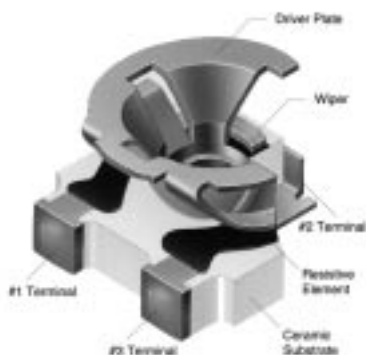

■ Standard Land Pattern

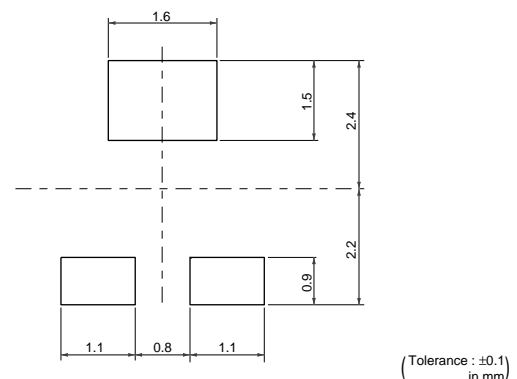

Continued on the following page.

 Continued from the preceding page.

■ Characteristics

Humidity Exposure	Res. Change : $\pm 3\%$
High Temperature Exposure	Res. Change : $\pm 3\%$
Humidity Load Life	Res. Change : $\pm 3\%$
Load Life	Res. Change : $\pm 3\%$
Temperature Cycle	Res. Change : $\pm 3\%$
Temperature Coefficient of Resistance	$\pm 250\text{ppm}/^\circ\text{C}$
Rotational Life	Res. Change : $\pm 10\%$ (10 cycles)

PVZ3/PVS3/PVA3 Series Notice

2

■ Notice (Operating and Storage Conditions)

1. Store in temperatures of -10 to +40 deg. C and relative humidity of 30-85%RH.
2. Do not store in or near corrosive gases.
3. Use within six months after delivery.
4. Open the package just before using.
5. Do not store under direct sunlight.
6. If you use the trimmer potentiometer in an environment other than listed below, please consult with a Murata factory representative prior to using.

The trimmer potentiometer should not be used under the following environmental conditions:

- (1) Corrosive gaseous atmosphere
(Ex. Chlorine gas, Hydrogen sulfide gas, Ammonia gas, Sulfuric acid gas, Nitric oxide gas, etc.)
- (2) In liquid
(Ex. Oil, Medical liquid, Organic solvent, etc.)
- (3) Dusty/dirty atmosphere
- (4) Direct sunlight
- (5) Static voltage nor electric/magnetic fields
- (6) Direct sea breeze
- (7) Other variations of the above

■ Notice (Rating)

1. When using with partial load (rheostat), minimize the power depending on the resistance value.
2. The maximum input voltage to a trimmer potentiometer should not exceed $(P \cdot R)^{1/2}$ or the maximum operating voltage, whichever is smaller.
3. If the trimmer potentiometer is used in DC and high humidity conditions, please connect wiper (#2) for plus and resistive element (#1 or #3) for minus.
(PVZ Series only)

■ Notice (Soldering and Mounting)

1. Soldering
 - (1) Soldering condition
Refer to the temperature profile.
If the soldering conditions are not suitable, e.g., excessive time and/or excessive temperature, the trimmer potentiometer may deviate from the specified characteristics.
 - (2) Flow soldering is available for PVA3 series.
For PVZ3 and PVS3, do not use flow soldering method (dipping).
If you use the flow soldering method, the trimmer potentiometer may not function.
 - (3) Use our standard land dimension. Excessive land area causes displacement due to the effect of the surface tension of the solder. Insufficient land area leads to insufficient soldering strength of the chip.
 - (4) Apply the appropriate amount of solder paste.
The thickness of solder paste should be printed from 150 micro m to 200 micro m (PVZ3 series should be printed from 100 micro m to 150 micro m) and the dimension of land pattern used should be Murata's standard land pattern at reflow soldering. Insufficient amounts of solder can lead to insufficient soldering strength on PCB.

Excessive amounts of solder may cause bridging between the terminals.

- (5) The soldering iron should not come in contact with the case of the trimmer potentiometer. If such contact does occur, the trimmer potentiometer may be damaged. (PVZ Series only)
2. Mounting
 - (1) Do not apply excessive force (preferably 4.9N (Ref.: 500gf) max.), when the trimmer potentiometer is mounted to the PCB.
 - (2) Do not warp and/or bend PC board to prevent trimmer potentiometer from breakage.
 - (3) In chip placers, the recommended size of the cylindrical pick-up nozzle should be outer dimension 2.5-2.8mm dia. and inner dimension 2mm dia.
3. Cleaning
 - (1) In case there is flux on the resistive element, clean sufficiently with cleaning solvents and completely remove all residual flux.
 - (2) Isopropyl-alcohol and Ethyl-alcohol are applicable solvents for cleaning. If you use any other types of solvents, please evaluate performance by your product.

PVZ3/PVS3/PVA3 Series Notice

■ Soldering Profile ● Flow Soldering Profile

Soldering profile for Lead-free solder (96.5Sn/3.0Ag/0.5Cu), Eutectic solder (63Sn/37Pb)

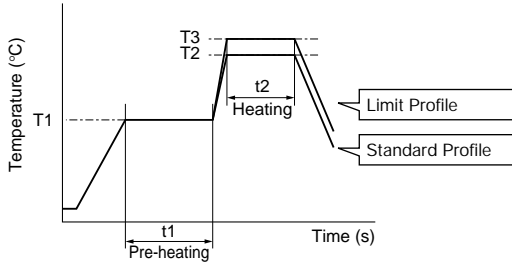

Series	Standard Profile					Limit Profile				
	Pre-heating		Heating		Cycle of Flow	Pre-heating		Heating		Cycle of Flow
	Temp. (T1) °C	Time (t1) sec.	Temp. (T2) °C	Time (t2) sec.		Temp. (T1) °C	Time (t1) sec.	Temp. (T3) °C	Time (t2) sec.	
PVA3	150	60 to 120	250	5 max.	1	150	60 to 120	265±3	5 max.	2

● Reflow Soldering Profile

1. Soldering profile for Lead-free solder (96.5Sn/3.0Ag/0.5Cu)

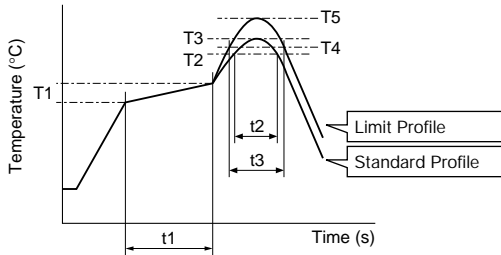

Series	Standard Profile						Limit Profile					
	Pre-heating		Heating		Peak Temperature (T3) °C	Cycle of Reflow	Pre-heating		Heating		Peak Temperature (T5) °C	Cycle of Reflow
	Temp. (T1) °C	Time (t1) sec.	Temp. (T2) °C	Time (t2) sec.			Temp. (T1) °C	Time (t1) sec.	Temp. (T4) °C	Time (t3) sec.		
PVA3	150 to 180	60 to 120	220	30 to 60	245±3	2	150 to 180	60 to 120	230	30 to 50	260 +5/-0	2
PVS3	150 to 180	60 to 120	220	30 to 60	245±3	2	150 to 180	60 to 120	220	30 to 60	260 +5/-0	2
PVZ3A***A01	130 to 160	60 to 120	200	20 to 50	240	1	130 to 160	60 to 120	200	20 to 50	240	2
PVZ3A***C01	150 to 180	60 to 120	220	30 to 60	245±3	2	150 to 180	60 to 120	220	30 to 60	260	2
PVZ3K***E01	150 to 180	60 to 120	220	30 to 60	245±3	2	150 to 180	60 to 120	220	30 to 60	260	2
PVZ3R***E01	150 to 180	60 to 120	220	30 to 60	245±3	2	150 to 180	60 to 120	220	30 to 60	260	2

2. Soldering profile for Eutectic solder (63Sn/37Pb)

(Limit profile: refer to 1)

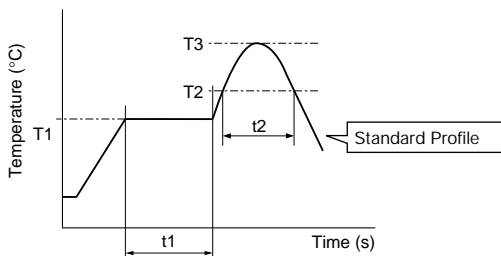

Series	Standard Profile					
	Pre-heating		Heating		Peak Temperature (T3) °C	Cycle of Reflow
	Temp. (T1) °C	Time (t1) sec.	Temp. (T2) °C	Time (t2) sec.		
PVA3 PVS3 PVZ3A***A01 PVZ3A***C01 PVZ3K***E01 PVZ3R***E01	150	60 to 120	183	30	230	1

● Soldering Iron

Series	Standard Condition			
	Temperature of Soldering Iron Tip °C	Soldering Time sec.	Soldering Iron Power Output W	Cycle of Soldering Iron Time
	PVA3, PVS3, PVZ3A***A01, PVZ3A***C01, PVZ3K***E01, PVZ3R***E01	350±10	3 max.	30 max.

PVZ3/PVS3/PVA3 Series Notice

■ Notice (Handling)

1. Use suitable screwdrivers that fit comfortably in driver slot. We recommend the screwdrivers below.
 - * Recommended screwdriver for manual adjustment
>VESSEL MFG.: NO.9000+1.7x30
(Murata P/N: KMDR080)
 - >TORAY MFG.: SA-2225 (Murata P/N: KMDR070)
 - * Recommended screwdriver for automatic adjustment
>TORAY MFG.: JB-2225 (Murata P/N: KMBT070)
2. Don't apply more than 4.9N (Ref.; 500gf) of twist and stress after mounting onto PCB to prevent contact intermittence. If excessive force is applied, the trimmer potentiometer may not function.
3. Please use within the effective rotational angle. PVZ3/PVA3 Series do not have a mechanical stop for over rotation. In cases out of effective rotational angle, the trimmer potentiometer may not function.
4. When using a lock paint to fix slot position or cover the rotor, please evaluate performance by your product. Lock paint may cause corrosion or electrical contact problems.

■ Notice (Other)

1. Please make sure that your product has been evaluated and confirmed against your specifications when our product is mounted to your product.
2. Murata cannot guarantee trimmer potentiometer integrity when used under conditions other than those specified in this document.

Trimmer Potentiometers



SMD Sealed Type 2mm Size PVF2 Series

■ Features

1. Ultra-compact size of "2x2x2.3mm"
2. A sealed structure prevents liquids (water, cleaning liquid, sweat, etc.) from entering.
3. As for the resistance change characteristics, both a log curve type and linear type are available.
4. A rotation service life of 100 cycles is guaranteed.
5. Can be automatically mounted using a chip placer, as well as mounted using reflow soldering.

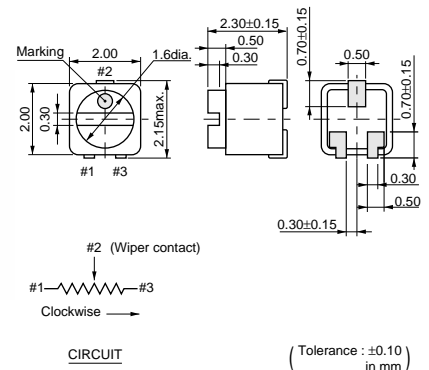

■ Applications

1. Hearing aids
2. Ultra-compact sensors or the like
3. Applications requiring ultra-compactness, and a sealed structure

Part Number	Power Rating (W)	Soldering Method	Number of Turns (Effective Rotation Angle)	Total Resistance Value	TCR (ppm/°C)
PVF2A501A11	0.001(50°C)	Reflow/Soldering Iron	1(210°±10°)	500ohm ±30%	±500
PVF2A102A11	0.001(50°C)	Reflow/Soldering Iron	1(210°±10°)	1k ohm ±30%	±500
PVF2A202A11	0.001(50°C)	Reflow/Soldering Iron	1(210°±10°)	2k ohm ±30%	±500
PVF2A502A11	0.001(50°C)	Reflow/Soldering Iron	1(210°±10°)	5k ohm ±30%	±500
PVF2A103A11	0.001(50°C)	Reflow/Soldering Iron	1(210°±10°)	10k ohm ±30%	±500
PVF2A203A11	0.001(50°C)	Reflow/Soldering Iron	1(210°±10°)	20k ohm ±30%	±500
PVF2A503A11	0.001(50°C)	Reflow/Soldering Iron	1(210°±10°)	50k ohm ±30%	±500
PVF2A104A11	0.001(50°C)	Reflow/Soldering Iron	1(210°±10°)	100k ohm ±30%	±500
PVF2A204A11	0.001(50°C)	Reflow/Soldering Iron	1(210°±10°)	200k ohm ±30%	±500
PVF2A504A11	0.001(50°C)	Reflow/Soldering Iron	1(210°±10°)	500k ohm ±30%	±500
PVF2A105A11	0.001(50°C)	Reflow/Soldering Iron	1(210°±10°)	1M ohm ±30%	±500
PVF2A102A41	0.001(50°C)	Reflow/Soldering Iron	1(210°±10°)	1k ohm ±30%	±500
PVF2A202A41	0.001(50°C)	Reflow/Soldering Iron	1(210°±10°)	2k ohm ±30%	±500
PVF2A502A41	0.001(50°C)	Reflow/Soldering Iron	1(210°±10°)	5k ohm ±30%	±500
PVF2A103A41	0.001(50°C)	Reflow/Soldering Iron	1(210°±10°)	10k ohm ±30%	±500
PVF2A203A41	0.001(50°C)	Reflow/Soldering Iron	1(210°±10°)	20k ohm ±30%	±500
PVF2A503A41	0.001(50°C)	Reflow/Soldering Iron	1(210°±10°)	50k ohm ±30%	±500
PVF2A104A41	0.001(50°C)	Reflow/Soldering Iron	1(210°±10°)	100k ohm ±30%	±500
PVF2A204A41	0.001(50°C)	Reflow/Soldering Iron	1(210°±10°)	200k ohm ±30%	±500
PVF2A504A41	0.001(50°C)	Reflow/Soldering Iron	1(210°±10°)	500k ohm ±30%	±500
PVF2A102A51	0.001(50°C)	Reflow/Soldering Iron	1(210°±10°)	1k ohm ±30%	±500
PVF2A202A51	0.001(50°C)	Reflow/Soldering Iron	1(210°±10°)	2k ohm ±30%	±500
PVF2A502A51	0.001(50°C)	Reflow/Soldering Iron	1(210°±10°)	5k ohm ±30%	±500
PVF2A103A51	0.001(50°C)	Reflow/Soldering Iron	1(210°±10°)	10k ohm ±30%	±500
PVF2A203A51	0.001(50°C)	Reflow/Soldering Iron	1(210°±10°)	20k ohm ±30%	±500
PVF2A503A51	0.001(50°C)	Reflow/Soldering Iron	1(210°±10°)	50k ohm ±30%	±500
PVF2A104A51	0.001(50°C)	Reflow/Soldering Iron	1(210°±10°)	100k ohm ±30%	±500
PVF2A204A51	0.001(50°C)	Reflow/Soldering Iron	1(210°±10°)	200k ohm ±30%	±500
PVF2A504A51	0.001(50°C)	Reflow/Soldering Iron	1(210°±10°)	500k ohm ±30%	±500
PVF2A102A81	0.001(50°C)	Reflow/Soldering Iron	1(210°±10°)	1k ohm ±30%	±500
PVF2A202A81	0.001(50°C)	Reflow/Soldering Iron	1(210°±10°)	2k ohm ±30%	±500
PVF2A502A81	0.001(50°C)	Reflow/Soldering Iron	1(210°±10°)	5k ohm ±30%	±500
PVF2A103A81	0.001(50°C)	Reflow/Soldering Iron	1(210°±10°)	10k ohm ±30%	±500
PVF2A203A81	0.001(50°C)	Reflow/Soldering Iron	1(210°±10°)	20k ohm ±30%	±500

Continued on the following page.

Continued from the preceding page.

Part Number	Power Rating (W)	Soldering Method	Number of Turns (Effective Rotation Angle)	Total Resistance Value	TCR (ppm/°C)
PVF2A503A81	0.001(50°C)	Reflow/Soldering Iron	1(210°±10°)	50k ohm ±30%	±500
PVF2A104A81	0.001(50°C)	Reflow/Soldering Iron	1(210°±10°)	100k ohm ±30%	±500
PVF2A204A81	0.001(50°C)	Reflow/Soldering Iron	1(210°±10°)	200k ohm ±30%	±500
PVF2A504A81	0.001(50°C)	Reflow/Soldering Iron	1(210°±10°)	500k ohm ±30%	±500
PVF2A102A91	0.001(50°C)	Reflow/Soldering Iron	1(210°±10°)	1k ohm ±30%	±500
PVF2A202A91	0.001(50°C)	Reflow/Soldering Iron	1(210°±10°)	2k ohm ±30%	±500
PVF2A502A91	0.001(50°C)	Reflow/Soldering Iron	1(210°±10°)	5k ohm ±30%	±500
PVF2A103A91	0.001(50°C)	Reflow/Soldering Iron	1(210°±10°)	10k ohm ±30%	±500
PVF2A203A91	0.001(50°C)	Reflow/Soldering Iron	1(210°±10°)	20k ohm ±30%	±500
PVF2A503A91	0.001(50°C)	Reflow/Soldering Iron	1(210°±10°)	50k ohm ±30%	±500
PVF2A104A91	0.001(50°C)	Reflow/Soldering Iron	1(210°±10°)	100k ohm ±30%	±500
PVF2A204A91	0.001(50°C)	Reflow/Soldering Iron	1(210°±10°)	200k ohm ±30%	±500
PVF2A504A91	0.001(50°C)	Reflow/Soldering Iron	1(210°±10°)	500k ohm ±30%	±500

Operating Temperature Range: -25 to 60 °C

The last three digits express the individual specification codes for Resistant Curve. Please refer to Resistance Curve on the following page for characteristics.

Construction

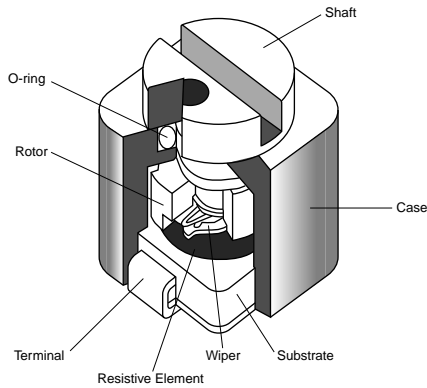

Standard Land Pattern

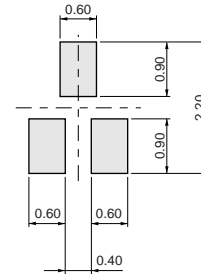

(Tolerance : ±0.10 in mm)

Characteristics

Temperature Cycle	ΔTR ±5%
Humidity	ΔTR ±15, -2%
Vibration	ΔV.S.S. ±5%
Shock (100G)	ΔV.S.S. ±5%
Temperature Load Life	ΔTR +2, -10%
Low Temperature Exposure	ΔTR ±3%
Rotational Life (100 cycles)	ΔTR ±10%

ΔTR: Total Resistance Change
 ΔV.S.S.: Voltage Setting Stability

Resistance Curve

Linear-log. curve (Measured from terminal 1 to 2)

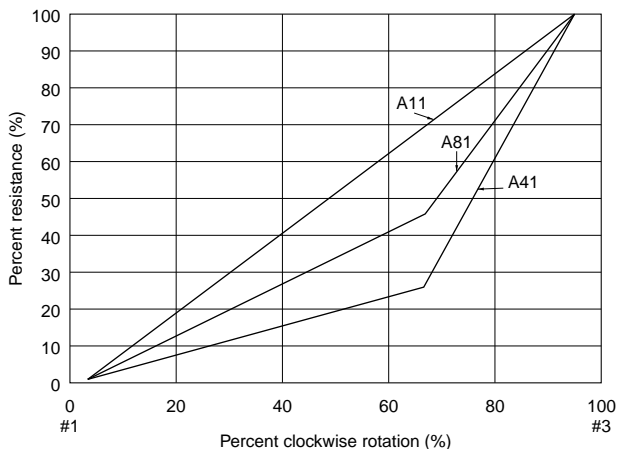

Linear-log. log. curve (Measured from terminal 2 to 3)

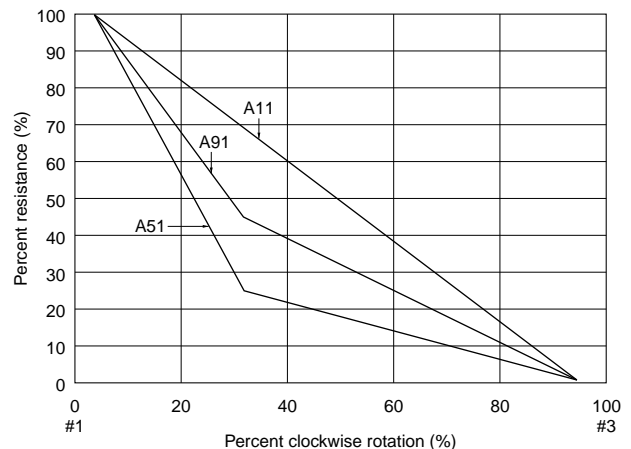

PVF2 Series Notice

■ Notice (Operating and Storage Conditions)

1. Store in temperatures of -10 to +40 deg. C and relative humidity of 30-85%RH.
2. Do not store in or near corrosive gases.
3. Use within six months after delivery.
4. Open the package just before using.
5. Do not store under direct sunlight.
6. If you use the trimmer potentiometer in an environment other than listed below, please consult with a Murata factory representative prior to using.
The trimmer potentiometer should not be used under the following environmental conditions:

- (1) Corrosive gaseous atmosphere
(Ex. Chlorine gas, Hydrogen sulfide gas, Ammonia gas, Sulfuric acid gas, Nitric oxide gas, etc.)
- (2) In liquid
(Ex. Oil, Medical liquid, Organic solvent, etc.)
- (3) Dusty/dirty atmosphere
- (4) Direct sunlight
- (5) Static voltage nor electric/magnetic fields
- (6) Direct sea breeze
- (7) Other variations of the above

■ Notice (Rating)

1. When using with partial load (rheostat), minimize the power depending on the resistance value.
2. The maximum input voltage to a trimmer potentiometer should not exceed $(P \cdot R)^{1/2}$ or the maximum operating voltage, whichever is smaller.
3. If the trimmer potentiometer is used in DC and high humidity conditions, please connect wiper (#2) for plus and resistive element (#1 or #3) for minus.

■ Notice (Soldering and Mounting)

1. Soldering
 - (1) Soldering condition
Refer to the temperature profile.
If the soldering conditions are not suitable, e.g., excessive time and/or excessive temperature, the trimmer potentiometer may deviate from the specified characteristics.
 - (2) Use our standard land dimension. Excessive land area causes displacement due to the effect of the surface tension of the solder. Insufficient land area leads to insufficient soldering strength of the chip.
 - (3) The soldering iron should not come in contact with the case of the trimmer potentiometer. If such contact does occur, the trimmer potentiometer may be damaged.
 - (4) Cannot be soldered using the flow soldering method. If you use the flow soldering method, the trimmer potentiometer may not function.
2. Mounting
 - (1) Use our standard land dimension. Excessive land area causes displacement due to the effect of the surface tension of the solder. Insufficient land area leads to insufficient soldering strength of the chip.
 - (2) Do not apply excessive force (preferably 4.9N (Ref.: 500gf) max.), when the trimmer potentiometer is mounted to the PCB.
 - (3) Do not warp and/or bend PC board to prevent trimmer potentiometer from breakage.
3. Cleaning
 - (1) Isopropyl-alcohol and Ethyl-alcohol are applicable solvents for cleaning. If you use any other types of solvents, please consult with a Murata factory representative prior to using.
 - (2) The total cleaning time by cold dipping, vapor and ultrasonic washing (conditions as below) method should be less than 3 minutes.
 - (3) For ultra-sonic cleaning, the available condition is as follows.
 - >Power: 600W (67 liter) max.
 - >Frequency: 28kHz
 - >Temperature: Ambient temperatureDue to the ultra-sonic cleaning equipment's peculiar self-resonance point and that the cleaning compatibility usually depends on the jig construction and/or the cleaning condition such as the depth of immersion, please check the cleaning equipment to determine the suitable conditions.
If the trimmer potentiometer is cleaned by other conditions, the trimmer potentiometer may be damaged.

PVF2 Series Notice

■ Soldering Profile

● Reflow Soldering Profile

1. Soldering profile for Lead-free solder (96.5Sn/3.0Ag/0.5Cu)

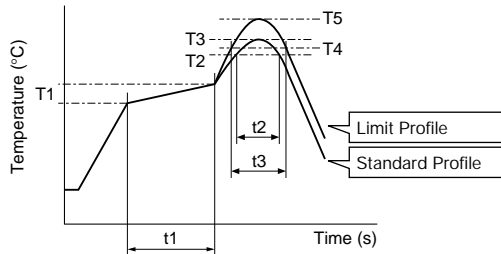

Standard Profile					
Pre-heating		Heating		Peak Temperature (T3)	Cycle of Reflow
Temp. (T1)	Time (t1)	Temp. (T2)	Time (t2)		
°C	sec.	°C	sec.	°C	Time
150 to 180	60 to 120	200	30	230	1

Limit Profile					
Pre-heating		Heating		Peak Temperature (T5)	Cycle of Reflow
Temp. (T1)	Time (t1)	Temp. (T4)	Time (t3)		
°C	sec.	°C	sec.	°C	Time
150 to 180	60 to 120	200	40	240	1

2. Soldering profile for Eutectic solder (63Sn/37Pb)
(Limit profile: refer to 1)

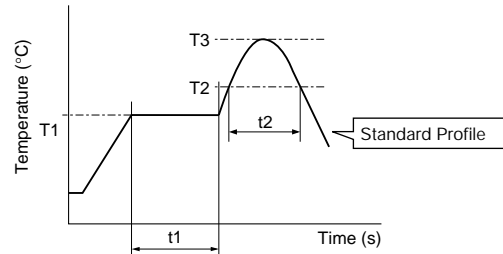

Standard Profile					
Pre-heating		Heating		Peak Temperature (T3)	Cycle of Reflow
Temp. (T1)	Time (t1)	Temp. (T2)	Time (t2)		
°C	sec.	°C	sec.	°C	Time
150	60 to 120	183	30	230	1

● Soldering Iron

Standard Condition			
Temperature of Soldering Iron Tip	Soldering Time	Soldering Iron Power Output	Cycle of Soldering Iron
°C	sec.	W	Time
260	3 max.	30 max.	1

■ Notice (Handling)

1. Use suitable screwdrivers that fit comfortably in driver slot.
2. Don't apply more than 4.9N (Ref.; 500gf) of twist and stress after mounting onto PCB to prevent contact intermittence. If excessive force is applied, the trimmer potentiometer may not function.
3. The rotational torque at the position of the adjustment range should not exceed the stop strength.
4. When using a lock paint to fix slot position, please use adhesive resin without chlorine or sulfur (Three-bond "1401 series").

■ Notice (Other)

1. Please make sure that your product has been evaluated and confirmed against your specifications when our product is mounted to your product.
2. Murata cannot guarantee trimmer potentiometer integrity when used under conditions other than those specified in this document.

Trimmer Potentiometers



SMD Sealed Type 3mm Size PVG3 Series

■ Features

1. Sealed construction protects the interior from dust and liquid, which achieves stable performance.
2. Driver plate with cross-slot is suitable for automatic adjustment.
3. Rotor with large diameter and deep groove improves driver insertion.
4. J-hook, Gull wing terminal shape. Rear and through hole terminal shape.
5. 3mm and 4mm land pattern can be used without change. (Gull wing is suitable for 4mm size land pattern.)
6. Heat resistance performance enables high temperature peak re-flow soldering.
7. To be complied with RoHS directive by new Cd free cermet resistive material. Pb free terminals with Sn plating.

■ Applications

1. Small sensors
2. Optical Transceiver Module
3. Copier
4. Printer
5. Compact Power Supply
6. Wireless Radio module



PVG3A

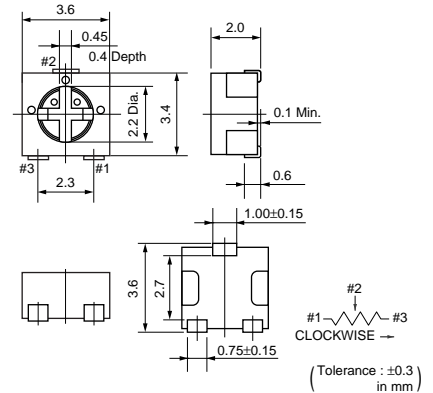

PVG3G

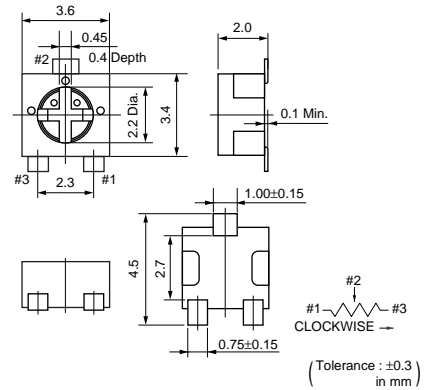

PVG3K

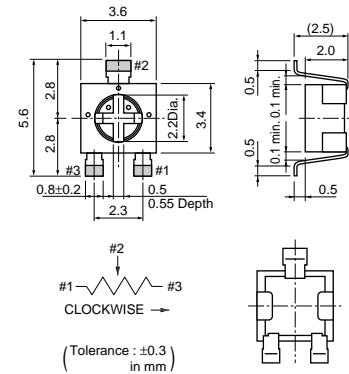

Part Number	Power Rating (W)	Soldering Method	Number of Turns (Effective Rotation Angle)	Total Resistance Value	TCR (ppm/°C)
PVG3□100C01	0.25(70°C)	Reflow/Soldering Iron	1(210°±10°)	10ohm ±20%	±150
PVG3□200C01	0.25(70°C)	Reflow/Soldering Iron	1(210°±10)	20ohm ±20%	±150
PVG3□500C01	0.25(70°C)	Reflow/Soldering Iron	1(210°±10°)	50ohm ±20%	±150
PVG3□101C01	0.25(70°C)	Reflow/Soldering Iron	1(210°±10°)	100ohm ±20%	±150
PVG3□201C01	0.25(70°C)	Reflow/Soldering Iron	1(210°±10°)	200ohm ±20%	±150
PVG3□501C01	0.25(70°C)	Reflow/Soldering Iron	1(210°±10°)	500ohm ±20%	±150
PVG3□102C01	0.25(70°C)	Reflow/Soldering Iron	1(210°±10°)	1k ohm ±20%	±150
PVG3□202C01	0.25(70°C)	Reflow/Soldering Iron	1(210°±10°)	2k ohm ±20%	±150
PVG3□502C01	0.25(70°C)	Reflow/Soldering Iron	1(210°±10°)	5k ohm ±20%	±150
PVG3□103C01	0.25(70°C)	Reflow/Soldering Iron	1(210°±10°)	10k ohm ±20%	±150
PVG3□203C01	0.25(70°C)	Reflow/Soldering Iron	1(210°±10°)	20k ohm ±20%	±150
PVG3□503C01	0.25(70°C)	Reflow/Soldering Iron	1(210°±10°)	50k ohm ±20%	±150

Continued on the following page. ↗

Continued from the preceding page.

Part Number	Power Rating (W)	Soldering Method	Number of Turns (Effective Rotation Angle)	Total Resistance Value	TCR (ppm/°C)
PVG3□104C01	0.25(70°C)	Reflow/Soldering Iron	1(210°±10°)	100k ohm ±20%	±150
PVG3□204C01	0.25(70°C)	Reflow/Soldering Iron	1(210°±10°)	200k ohm ±20%	±150
PVG3□504C01	0.25(70°C)	Reflow/Soldering Iron	1(210°±10°)	500k ohm ±20%	±150
PVG3□105C01	0.25(70°C)	Reflow/Soldering Iron	1(210°±10°)	1M ohm ±20%	±150
PVG3□205C01	0.25(70°C)	Reflow/Soldering Iron	1(210°±10°)	2M ohm ±20%	±150

Operating Temperature Range: -55 to 125 °C

The blank column is filled with the code of adjustment direction and lead type A (top, J-hook), G (top, gull-wing), or K (rear).

Construction

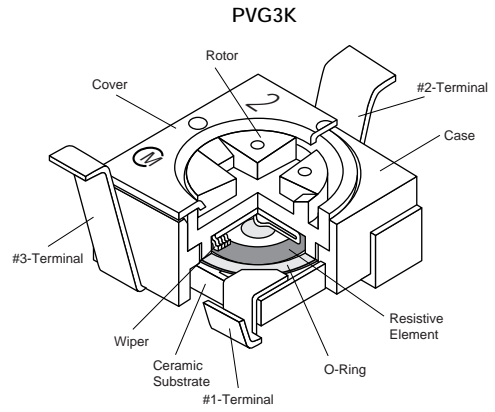
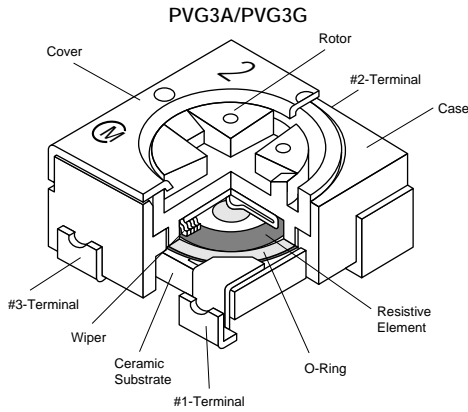

Standard Land Pattern

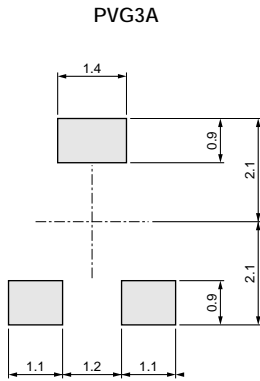

(Tolerance : ±0.1 in mm)

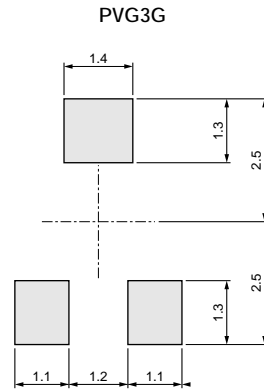

(Tolerance : ±0.1 in mm)

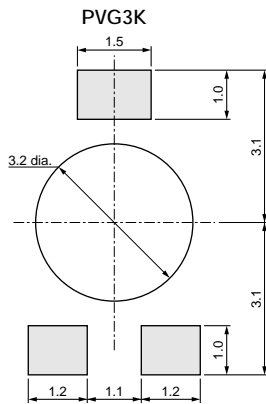

(Tolerance : ±0.1 in mm)

Continued on the following page. ↗

 Continued from the preceding page.

■ Characteristics

Temperature Cycle	ΔTR $\pm 2\%$ $\Delta V.S.S$ $\pm 1\%$
Humidity	ΔTR $\pm 2\%$ $\Delta V.S.S$ $\pm 1\%$ IR 10M ohm min.
Vibration (20G)	ΔTR $\pm 1\%$ $\Delta V.S.S$ $\pm 1\%$
Shock (100G)	ΔTR $\pm 1\%$ $\Delta V.S.S$ $\pm 1\%$
Temperature Load Life	ΔTR $\pm 3\%$ or 3 ohm max., whichever is greater $\Delta V.S.S$ $\pm 1\%$
Low Temperature Exposure	ΔTR $\pm 2\%$ $\Delta V.S.S$ $\pm 2\%$
High Temperature Exposure	ΔTR $\pm 3\%$ $\Delta V.S.S$ $\pm 2\%$
Rotational Life (50 cycles)	ΔTR $R \leq 100 \text{ kohm} \dots \pm 3\%$ or 2 ohm max., whichever is greater $R > 100 \text{ kohm} \dots +0/-10\%$

ΔTR : Total Resistance Change
 $\Delta V.S.S$: Voltage Setting Stability
 IR : Insulation Resistance
 R : Standard Total Resistance

PVG3 Series Notice

■ Notice (Operating and Storage Conditions)

1. Store in temperatures of -10 to +40 deg. C and relative humidity of 30-85%RH.
2. Do not store in or near corrosive gases.
3. Use within six months after delivery.
4. Open the package just before using.
5. Do not store under direct sunlight.
6. If you use the trimmer potentiometer in an environment other than listed below, please consult with a Murata factory representative prior to using.
The trimmer potentiometer should not be used under the following environmental conditions:

- (1) Corrosive gaseous atmosphere
(Ex. Chlorine gas, Hydrogen sulfide gas, Ammonia gas, Sulfuric acid gas, Nitric oxide gas, etc.)
- (2) In liquid
(Ex. Oil, Medical liquid, Organic solvent, etc.)
- (3) Dusty/dirty atmosphere
- (4) Direct sunlight
- (5) Static voltage nor electric/magnetic fields
- (6) Direct sea breeze
- (7) Other variations of the above

■ Notice (Rating)

1. When using with partial load (rheostat), minimize the power depending on the resistance value.
2. The maximum input voltage to a trimmer potentiometer should not exceed $(P \cdot R)^{1/2}$ or the maximum operating voltage, whichever is smaller.
3. The maximum input current to a trimmer potentiometer should not exceed $(P/R)^{1/2}$ or the allowable wiper current, whichever is smaller.

■ Notice (Soldering and Mounting)

1. Soldering
 - (1) Soldering condition
Refer to the temperature profile.
If the soldering conditions are not suitable, e.g., excessive time and/or excessive temperature, the trimmer potentiometer may deviate from the specified characteristics.
 - (2) Cannot be soldered using the flow soldering method. If you use the flow soldering method, the trimmer potentiometer may not function.
 - (3) The soldering iron should not come in contact with the case of the trimmer potentiometer. If such contact does occur, the trimmer potentiometer may be damaged.
 - (4) Apply the appropriate amount of solder paste.
If the amount of solder paste applied to the land is insufficient, the required adhesive strength cannot be obtained. If an excessive amount of solder paste is applied, solder bridging or flux overflow to the resistive element surface can occur.
 2. Mounting
 - (1) Use our standard land dimension. Excessive land area causes displacement due to the effect of the surface tension of the solder. Insufficient land area leads to insufficient soldering strength of the chip.
 - (2) Do not apply excessive force (preferably 4.9N (Ref.; 500gf) max.), when the trimmer potentiometer is mounted to the PCB.
 - (3) Do not warp and/or bend PC board to prevent trimmer potentiometer from breakage.
 - (4) In chip placers, the size of the cylindrical pick-up nozzle should be outer dimension 2.5-3.0mm dia. and inner dimension 2.0-2.5mm dia.
 3. Cleaning
 - (1) Isopropyl-alcohol and Ethyl-alcohol are applicable solvents for cleaning. If you use any other types of solvents, please consult with a Murata factory representative prior to using.
 - (2) Less than 3 minutes of total cleaning time by dipping, vapor and ultra-sonic method.
 - (3) In case of ultra-sonic cleaning method, cleaning conditions should be as follows.
 - (a) Power: 600W (67lit.) max.
 - (b) Frequency: 28kHz
 - (c) Temperature: Ambient temperature
Due to ultra-sonic cleaning equipment's peculiar self-resonance point and that cleaning compatibility usually depends on the jig construction and/or the cleaning condition such as the depth of immersion, please check the cleaning equipment to determine the suitable conditions.
- If the condition is not suitable, the trimmer potentiometer may deviate from specified characteristics.

PVG3 Series Notice

■ Soldering Profile

● Reflow Soldering Profile

1. Soldering profile for Lead-free solder (96.5Sn/3.0Ag/0.5Cu)

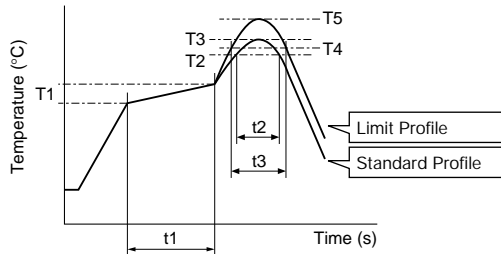

Standard Profile					
Pre-heating		Heating		Peak Temperature (T3)	Cycle of Reflow
Temp. (T1)	Time (t1)	Temp. (T2)	Time (t2)		
°C	sec.	°C	sec.	°C	Time
150 to 180	60 to 120	220	30 to 60	245±3	1

Limit Profile					
Pre-heating		Heating		Peak Temperature (T5)	Cycle of Reflow
Temp. (T1)	Time (t1)	Temp. (T4)	Time (t3)		
°C	sec.	°C	sec.	°C	Time
150 to 180	60 to 120	230	30 to 50	260 +5/-0	2

2. Soldering profile for Eutectic solder (63Sn/37Pb)
(Limit profile: refer to 1)

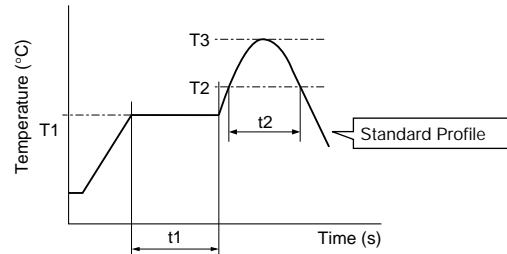

Standard Profile					
Pre-heating		Heating		Peak Temperature (T3)	Cycle of Reflow
Temp. (T1)	Time (t1)	Temp. (T2)	Time (t2)		
°C	sec.	°C	sec.	°C	Time
150	60 to 120	183	30	230	1

4

● Soldering Iron

Standard Condition			
Temperature of Soldering Iron Tip	Soldering Time	Soldering Iron Power Output	Cycle of Soldering Iron
°C	sec.	W	Time
350±10	3 max.	30 max.	1

■ Notice (Handling)

1. Use suitable screwdrivers that fit comfortably in driver slot.

* Recommended screwdriver for manual adjustment
TORAY INDUSTRIES, INC.: SA-2225
(Murata P/N: KMDR070)

* Recommended screwdriver bit for automatic adjustment
TORAY INDUSTRIES, INC.: JB-2225
(Murata P/N: KMBT070)

We can supply the screwdrivers above.

If you place order, please specify the Murata P/N.

2. Don't apply more than 9.8N (Ref.; 1kgf) of twist and stress after mounting onto PCB to prevent contact intermittence.

3. When adjusting with an adjustment tool, the applied force to the adjustment screw should not exceed 4.9N (Ref.; 500gf). If excessive force is applied, the trimmer potentiometer may not function due to damage.

4. The rotational torque at the position of the adjustment range should not exceed the stop strength.

5. When using a lock paint to fix slot position, please use adhesive resin without chlorine or sulfur (Three-bond "1401 series") and evaluate performance by your products. Lock paint may cause corrosion or electrical contact problems.

■ Notice (Other)

1. Please make sure that your product has been evaluated and confirmed against your specifications when our product is mounted to your product.

2. Murata cannot guarantee trimmer potentiometer integrity when used under conditions other than those specified in this document.

Trimmer Potentiometers



SMD Sealed Type 4mm Size PVM4 Series

■ Features

1. Sealed construction protects the interior from dust and liquid, which achieves stable performance.
2. Available for flow and reflow soldering method while maintaining unique sealed construction.
3. Simple construction by 3-piece parts achieves high reliability.
4. Large diameter slot of rotor improves driver insertion.
5. Available for cleaning after soldering
6. High grade version is available (PVM4AxxxD01).
7. To be complied with RoHS directive by new Cd free cermet resistive material. Pb free terminals with Sn plating.

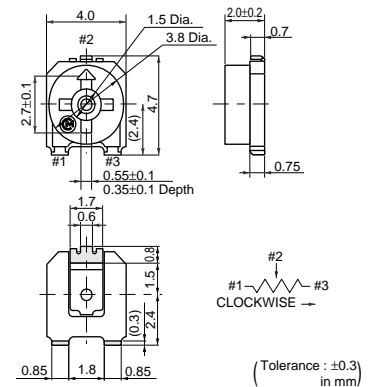

■ Applications

1. Security
2. OA, FA equipments
3. Measuring equipments
4. Professional cameras
5. Encoders
6. Sensors

Part Number	Power Rating (W)	Soldering Method	Number of Turns (Effective Rotation Angle)	Total Resistance Value	TCR (ppm/°C)
PVM4A101C01	0.1(70°C)	Flow/Reflow/Soldering Iron	1(240°±10°)	100ohm ±25%	±250
PVM4A201C01	0.1(70°C)	Flow/Reflow/Soldering Iron	1(240°±10°)	200ohm ±25%	±250
PVM4A301C01	0.1(70°C)	Flow/Reflow/Soldering Iron	1(240°±10°)	300ohm ±25%	±250
PVM4A501C01	0.1(70°C)	Flow/Reflow/Soldering Iron	1(240°±10°)	500ohm ±25%	±250
PVM4A102C01	0.1(70°C)	Flow/Reflow/Soldering Iron	1(240°±10°)	1k ohm ±25%	±250
PVM4A202C01	0.1(70°C)	Flow/Reflow/Soldering Iron	1(240°±10°)	2k ohm ±25%	±250
PVM4A302C01	0.1(70°C)	Flow/Reflow/Soldering Iron	1(240°±10°)	3k ohm ±25%	±250
PVM4A502C01	0.1(70°C)	Flow/Reflow/Soldering Iron	1(240°±10°)	5k ohm ±25%	±250
PVM4A103C01	0.1(70°C)	Flow/Reflow/Soldering Iron	1(240°±10°)	10k ohm ±25%	±250
PVM4A203C01	0.1(70°C)	Flow/Reflow/Soldering Iron	1(240°±10°)	20k ohm ±25%	±250
PVM4A303C01	0.1(70°C)	Flow/Reflow/Soldering Iron	1(240°±10°)	30k ohm ±25%	±250
PVM4A503C01	0.1(70°C)	Flow/Reflow/Soldering Iron	1(240°±10°)	50k ohm ±25%	±250
PVM4A104C01	0.1(70°C)	Flow/Reflow/Soldering Iron	1(240°±10°)	100k ohm ±25%	±250
PVM4A204C01	0.1(70°C)	Flow/Reflow/Soldering Iron	1(240°±10°)	200k ohm ±25%	±250
PVM4A304C01	0.1(70°C)	Flow/Reflow/Soldering Iron	1(240°±10°)	300k ohm ±25%	±250
PVM4A504C01	0.1(70°C)	Flow/Reflow/Soldering Iron	1(240°±10°)	500k ohm ±25%	±250
PVM4A105C01	0.1(70°C)	Flow/Reflow/Soldering Iron	1(240°±10°)	1M ohm ±25%	±250
PVM4A205C01	0.1(70°C)	Flow/Reflow/Soldering Iron	1(240°±10°)	2M ohm ±25%	±250
PVM4A101D01	0.25(70°C)	Flow/Reflow/Soldering Iron	1(240°±10°)	100ohm ±20%	±100
PVM4A201D01	0.25(70°C)	Flow/Reflow/Soldering Iron	1(240°±10°)	200ohm ±20%	±100
PVM4A301D01	0.25(70°C)	Flow/Reflow/Soldering Iron	1(240°±10°)	300ohm ±20%	±100
PVM4A501D01	0.25(70°C)	Flow/Reflow/Soldering Iron	1(240°±10°)	500ohm ±20%	±100
PVM4A102D01	0.25(70°C)	Flow/Reflow/Soldering Iron	1(240°±10°)	1k ohm ±20%	±200
PVM4A202D01	0.25(70°C)	Flow/Reflow/Soldering Iron	1(240°±10°)	2k ohm ±20%	±200
PVM4A302D01	0.25(70°C)	Flow/Reflow/Soldering Iron	1(240°±10°)	3k ohm ±20%	±200
PVM4A502D01	0.25(70°C)	Flow/Reflow/Soldering Iron	1(240°±10°)	5k ohm ±20%	±200
PVM4A103D01	0.25(70°C)	Flow/Reflow/Soldering Iron	1(240°±10°)	10k ohm ±20%	±150
PVM4A203D01	0.25(70°C)	Flow/Reflow/Soldering Iron	1(240°±10°)	20k ohm ±20%	±150
PVM4A303D01	0.25(70°C)	Flow/Reflow/Soldering Iron	1(240°±10°)	30k ohm ±20%	±150
PVM4A503D01	0.25(70°C)	Flow/Reflow/Soldering Iron	1(240°±10°)	50k ohm ±20%	±150

Continued on the following page.

Continued from the preceding page.

Part Number	Power Rating (W)	Soldering Method	Number of Turns (Effective Rotation Angle)	Total Resistance Value	TCR (ppm/°C)
PVM4A104D01	0.25(70°C)	Flow/Reflow/Soldering Iron	1(240°±10°)	100k ohm ±20%	±150
PVM4A204D01	0.25(70°C)	Flow/Reflow/Soldering Iron	1(240°±10°)	200k ohm ±20%	±150
PVM4A304D01	0.25(70°C)	Flow/Reflow/Soldering Iron	1(240°±10°)	300k ohm ±20%	±150
PVM4A504D01	0.25(70°C)	Flow/Reflow/Soldering Iron	1(240°±10°)	500k ohm ±20%	±150
PVM4A105D01	0.25(70°C)	Flow/Reflow/Soldering Iron	1(240°±10°)	1M ohm ±20%	±150
PVM4A205D01	0.25(70°C)	Flow/Reflow/Soldering Iron	1(240°±10°)	2M ohm ±20%	±150

Operating Temperature Range: -55 to 125 °C

The last three digits express the individual specification codes. C01 for standard type and D01 for high-liability type.

Construction

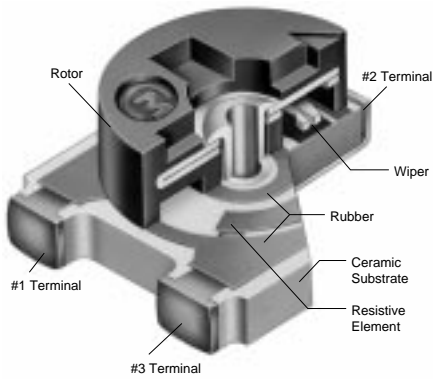

Standard Land Pattern

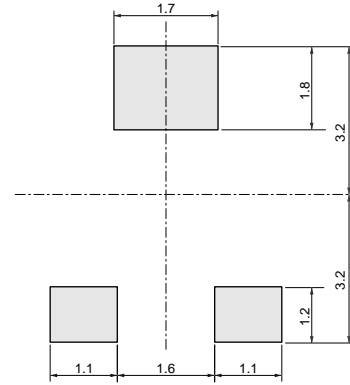

(Tolerance : ±0.1 in mm)

5

Characteristics

Item	PVM4A□□□C01	PVM4A□□□D01
Humidity Exposure	Res. Change : ±3%	Res. Change : ±2%
High Temperature Exposure	Res. Change : ±3%	Res. Change : ±2%
Humidity Load Life	Res. Change : ±3%	Res. Change : ±3%
Temperature Load Life	Res. Change : ±3%	Res. Change : ±3%
Temperature Cycle	Res. Change : ±3%	Res. Change : ±2%
Rotational Life	Res. Change : ±10% (20 cycles)	Res. Change : ±5% (100 cycles)

PVM4 Series Notice

■ Notice (Operating and Storage Conditions)

1. Store in temperatures of -10 to +40 deg. C and relative humidity of 30-85%RH.
2. Do not store in or near corrosive gases.
3. Use within six months after delivery.
4. Open the package just before using.
5. Do not store under direct sunlight.
6. If you use the trimmer potentiometer in an environment other than listed below, please consult with a Murata factory representative prior to using.
The trimmer potentiometer should not be used under the following environmental conditions:

■ Notice (Rating)

1. When using with partial load (rheostat), minimize the power depending on the resistance value.
2. The maximum input voltage to a trimmer potentiometer should not exceed $(P \cdot R)^{1/2}$ or the maximum operating voltage, whichever is smaller.

■ Notice (Soldering and Mounting)

1. Soldering
 - (1) Can be soldered by reflow soldering method, flow soldering method, and soldering iron. (In case of flow soldering, it is necessary to clean after soldering.)
 - (2) Use our standard land dimension. Excessive land area causes displacement due to the effect of the surface tension of the solder. Insufficient land area leads to insufficient soldering strength of the chip.
 - (3) Soldering condition
Refer to the temperature profile.
If the soldering conditions are not suitable, e.g., excessive time and/or excessive temperature, the trimmer potentiometer may deviate from the specified characteristics.
 - (4) Apply the appropriate amount of solder paste.
The thickness of solder paste should be printed from 100 micro m to 150 micro m and the dimension of land pattern used should be Murata's standard land pattern at reflow soldering. Insufficient amounts of solder can lead to insufficient soldering strength on PCB. Excessive amounts of solder may cause bridging between the terminals.
 - (5) The soldering iron should not come in contact with the case of the trimmer potentiometer. If such contact does occur, the trimmer potentiometer may be damaged.
2. Mounting
 - (1) Do not apply excessive force (preferably 9.8N (Ref.; 1kgf) max.), when the trimmer potentiometer is mounted to the PCB.
 - (2) Do not warp and/or bend PC board to prevent trimmer potentiometer from breakage.

- (1) Corrosive gaseous atmosphere
(Ex. Chlorine gas, Hydrogen sulfide gas, Ammonia gas, Sulfuric acid gas, Nitric oxide gas, etc.)
- (2) In liquid
(Ex. Oil, Medical liquid, Organic solvent, etc.)
- (3) Dusty/dirty atmosphere
- (4) Direct sunlight
- (5) Static voltage nor electric/magnetic fields
- (6) Direct sea breeze
- (7) Other variations of the above

3. The maximum input current to a trimmer potentiometer should not exceed $(P/R)^{1/2}$ or the allowable wiper current, whichever is smaller.

- (3) In chip placers, the recommended size of the cylindrical pick-up nozzle should be outer dimension 4.0mm dia. and inner dimension 2.0mm dia.
3. Cleaning
 - (1) Isopropyl alcohol and Ethyl alcohol are available materials for cleaning.
For other materials, please consult with a Murata factory representative prior to using.
 - (2) The following are the recommended cleaning conditions for the potentiometer. If this part is cleaned under any other conditions than these listed below, the sealing construction may be damaged.
(Condition)
Type1: Cold dipping/max. 5 min.
Type2: Hot dipping/max. 2 min.
Type3: Ultra-sonic washing/max. 1 min.
(20W/litre or below)
Type4: Hot dipping/max. 1 min.+
Ultra-sonic washing/max.1 min.
(20W/litre or below)
Type5: Hot dipping/max. 1 min.+
Ultra-sonic washing/max. 30 sec.+
(20W/litre or below)/
(Preferably max. 30 sec.)
Vapor/max.30 sec.
Due to ultra-sonic cleaning equipment's peculiar self-resonance point and that cleaning compatibility usually depends on the jig construction and/or the cleaning condition such as the depth of immersion, please check the cleaning equipment to determine the suitable conditions.

If the condition is not suitable, the trimmer potentiometer may deviate from specified characteristics.

PVM4 Series Notice

■ Soldering Profile

● Flow Soldering Profile

Soldering profile for Lead-free solder (96.5Sn/3.0Ag/0.5Cu), Eutectic solder (63Sn/37Pb)

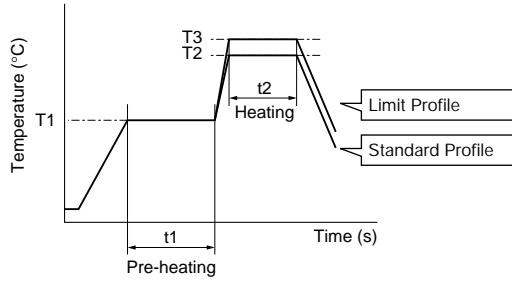

Standard Profile				
Pre-heating		Heating		Cycle of Flow
Temp. (T1)	Time (t1)	Temp. (T2)	Time (t2)	
°C	sec.	°C	sec.	Time
150	60 to 120	250	5 max.	1

Limit Profile				
Pre-heating		Heating		Cycle of Flow
Temp. (T1)	Time (t1)	Temp. (T3)	Time (t2)	
°C	sec.	°C	sec.	Time
150	60 to 120	265±3	5 max.	2

● Reflow Soldering Profile

1. Soldering profile for Lead-free solder (96.5Sn/3.0Ag/0.5Cu)

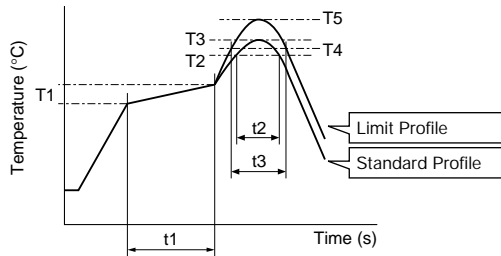

Standard Profile					
Pre-heating		Heating		Peak Temperature (T3)	Cycle of Reflow
Temp. (T1)	Time (t1)	Temp. (T2)	Time (t2)		
°C	sec.	°C	sec.	°C	Time
150 to 180	60 to 120	220	30 to 60	245±3	2

Limit Profile					
Pre-heating		Heating		Peak Temperature (T5)	Cycle of Reflow
Temp. (T1)	Time (t1)	Temp. (T4)	Time (t3)		
°C	sec.	°C	sec.	°C	Time
150 to 180	60 to 120	230	30 to 50	260 +5/-0	2

2. Soldering profile for Eutectic solder (63Sn/37Pb)

(Limit profile: refer to 1)

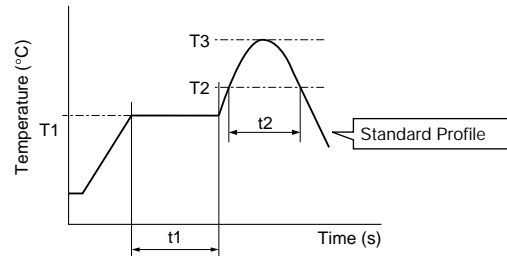

Standard Profile					
Pre-heating		Heating		Peak Temperature (T3)	Cycle of Reflow
Temp. (T1)	Time (t1)	Temp. (T2)	Time (t2)		
°C	sec.	°C	sec.	°C	Time
150	60 to 120	183	30	230	1

● Soldering Iron

Standard Condition			
Temperature of Soldering Iron Tip	Soldering Time	Soldering Iron Power Output	Cycle of Soldering Iron
°C	sec.	W	Time
350±10	3 max.	30 max.	1

5

PVM4 Series Notice

■ Notice (Handling)

1. Use suitable screwdrivers that fit comfortably in driver slot. We recommend the screwdriver below.
* Recommended screwdriver for manual adjustment
VESSEL MFG.: NO. 9000-2.6x30
(Murata P/N: KMDR120)
We can supply the screwdrivers above.
If you place order, please specify the Murata P/N.
2. Don't apply more than 4.9N (Ref.; 500gf) of twist and stress after mounting onto PCB to prevent contact intermittence. If excessive force is applied, the trimmer potentiometer may not function.

3. Please use within the effective rotational angle.
The potentiometer does not have a mechanical stop for over rotation. In cases out of effective rotational angle, the trimmer potentiometer may not function.
4. When using a lock paint to fix slot position, please use adhesive resin without chlorine or sulfur (Three-bond "1401 series") and evaluate performance by your products. Lock paint may cause corrosion or electrical contact problems.

■ Notice (Other)

1. Please make sure that your product has been evaluated and confirmed against your specifications when our product is mounted to your product.
2. Murata cannot guarantee trimmer potentiometer integrity when used under conditions other than those specified in this document.

Trimmer Potentiometers



SMD Sealed Type Multi-turns PVG5/PV01 Series

PVG5 Series

■ Features

1. Sealed construction protects the interior from dust and liquid, which achieves stable performance.
2. Available with reflow soldering method
3. Available for ultrasonic cleaning after soldering
4. Clutch mechanism prevents excessive wiper rotation.
5. Both Top and side adjustment directions
6. Ultra smaller volume (1/5-1/2) than leaded multi-turn potentiometer.
7. To be complied with RoHS directive by new Cd free cermet resistive material. Pb free terminals with Sn plating.

■ Applications

1. Measuring instruments
2. OA equipment
3. Medical equipment
4. Power supply
5. Sensors
6. Base station for cellular phone



PVG5A

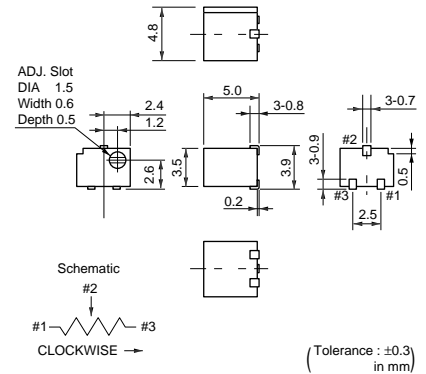

PVG5H

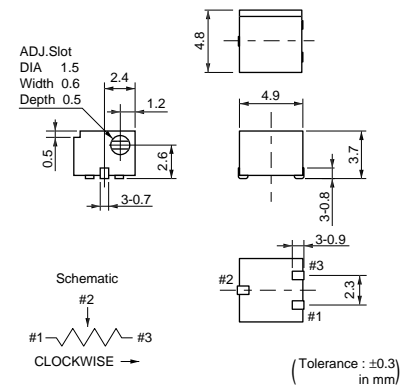

6

Part Number	Power Rating (W)	Soldering Method	Number of Turns (Effective Rotation Angle)	Total Resistance Value	TCR (ppm/°C)
PVG5□100C01	0.25(70°C)	Reflow/Soldering Iron	11	10ohm ±10%	±150
PVG5□200C01	0.25(70°C)	Reflow/Soldering Iron	11	20ohm ±10%	±150
PVG5□500C01	0.25(70°C)	Reflow/Soldering Iron	11	50ohm ±10%	±150
PVG5□101C01	0.25(70°C)	Reflow/Soldering Iron	11	100ohm ±10%	±150
PVG5□201C01	0.25(70°C)	Reflow/Soldering Iron	11	200ohm ±10%	±150
PVG5□501C01	0.25(70°C)	Reflow/Soldering Iron	11	500ohm ±10%	±150
PVG5□102C01	0.25(70°C)	Reflow/Soldering Iron	11	1k ohm ±10%	±150
PVG5□202C01	0.25(70°C)	Reflow/Soldering Iron	11	2k ohm ±10%	±150
PVG5□502C01	0.25(70°C)	Reflow/Soldering Iron	11	5k ohm ±10%	±150
PVG5□103C01	0.25(70°C)	Reflow/Soldering Iron	11	10k ohm ±10%	±150
PVG5□203C01	0.25(70°C)	Reflow/Soldering Iron	11	20k ohm ±10%	±150
PVG5□503C01	0.25(70°C)	Reflow/Soldering Iron	11	50k ohm ±10%	±150
PVG5□104C01	0.25(70°C)	Reflow/Soldering Iron	11	100k ohm ±10%	±150
PVG5□204C01	0.25(70°C)	Reflow/Soldering Iron	11	200k ohm ±10%	±150
PVG5□504C01	0.25(70°C)	Reflow/Soldering Iron	11	500k ohm ±10%	±150
PVG5□105C01	0.25(70°C)	Reflow/Soldering Iron	11	1M ohm ±10%	±150
PVG5□205C01	0.25(70°C)	Reflow/Soldering Iron	11	2M ohm ±10%	±150

Operating Temperature Range: -55 to 125 °C
 The blank column is filled with the code of adjustment direction A (top) or H (side).

Construction

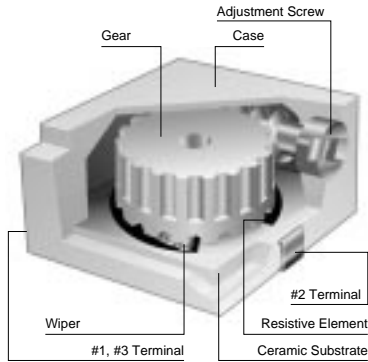

Standard Land Pattern

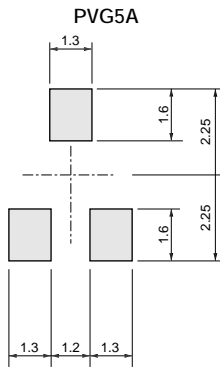

(Tolerance : ±0.1 in mm)

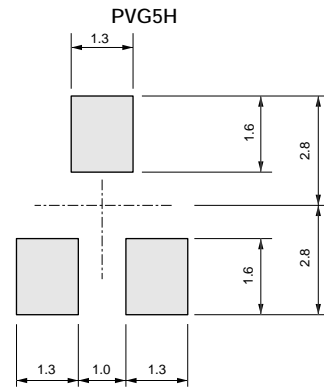

(Tolerance : ±0.1 in mm)

Characteristics

Temperature Cycle	ΔTR	±2%
	ΔV.S.S.	±1%
Humidity	ΔTR	±2%
	IR	10M ohm min.
Vibration (20G)	ΔTR	±1%
	ΔV.S.S.	±1%
Shock (100G)	ΔTR	±1%
	ΔV.S.S.	±1%
Temperature Load Life	ΔTR	±3% or 3 ohm max., whichever is greater
	ΔV.S.S.	±1%
Low Temperature Exposure	ΔTR	±1%
	ΔV.S.S.	±1%
High Temperature Exposure	ΔTR	±2%
	ΔV.S.S.	±1%
Rotational Life (100 cycles)	ΔTR	±3% or 3 ohm max., whichever is greater

ΔTR : Total Resistance Change
 ΔV.S.S. : Voltage Setting Stability
 IR : Insulation Resistance

PV01 Series

■ Features

1. Small size (6.35x6.35x4.3mm)
2. Sealed construction protects the interior from dust and liquid, which achieves stable performance.
3. Available with reflow soldering method
4. Available for ultrasonic cleaning after soldering
5. Clutch mechanism prevents excessive wiper rotation.
6. To be complied with RoHS directive by new Cd free cermet resistive material. Pb free terminals with Sn plating.

■ Applications

1. Measuring instruments
2. FAX
3. PPCs
4. Printers
5. Sensors



PV01P

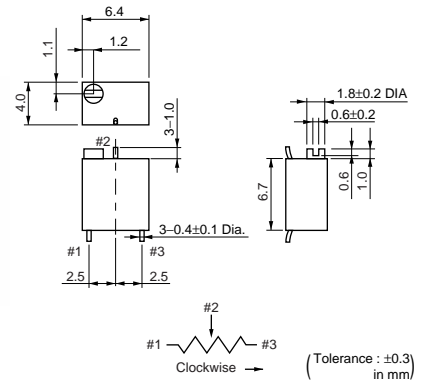

PV01W

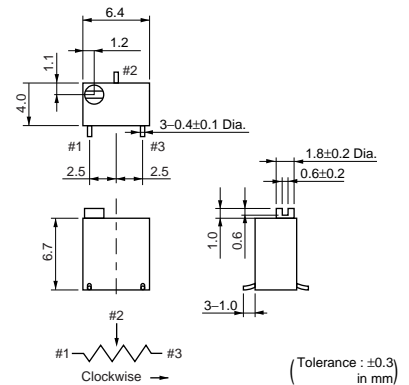

PV01X

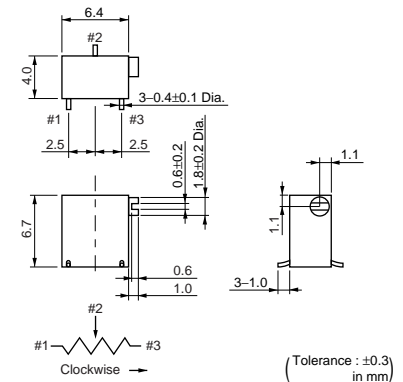

6

Part Number	Power Rating (W)	Soldering Method	Number of Turns (Effective Rotation Angle)	Total Resistance Value	TCR (ppm/°C)
PV01□100C01	0.25(85°C)	Reflow/Soldering Iron	12	10ohm ±10%	±150
PV01□200C01	0.25(85°C)	Reflow/Soldering Iron	12	20ohm ±10%	±150
PV01□500C01	0.25(85°C)	Reflow/Soldering Iron	12	50ohm ±10%	±150
PV01□101C01	0.25(85°C)	Reflow/Soldering Iron	12	100ohm ±10%	±150
PV01□201C01	0.25(85°C)	Reflow/Soldering Iron	12	200ohm ±10%	±150
PV01□501C01	0.25(85°C)	Reflow/Soldering Iron	12	500ohm ±10%	±150
PV01□102C01	0.25(85°C)	Reflow/Soldering Iron	12	1k ohm ±10%	±150
PV01□202C01	0.25(85°C)	Reflow/Soldering Iron	12	2k ohm ±10%	±150
PV01□502C01	0.25(85°C)	Reflow/Soldering Iron	12	5k ohm ±10%	±150
PV01□103C01	0.25(85°C)	Reflow/Soldering Iron	12	10k ohm ±10%	±150
PV01□203C01	0.25(85°C)	Reflow/Soldering Iron	12	20k ohm ±10%	±150
PV01□253C01	0.25(85°C)	Reflow/Soldering Iron	12	25k ohm ±10%	±150
PV01□503C01	0.25(85°C)	Reflow/Soldering Iron	12	50k ohm ±10%	±150
PV01□104C01	0.25(85°C)	Reflow/Soldering Iron	12	100k ohm ±10%	±150
PV01□204C01	0.25(85°C)	Reflow/Soldering Iron	12	200k ohm ±10%	±150
PV01□254C01	0.25(85°C)	Reflow/Soldering Iron	12	250k ohm ±10%	±150

Continued on the following page. ↗

Continued from the preceding page.

Part Number	Power Rating (W)	Soldering Method	Number of Turns (Effective Rotation Angle)	Total Resistance Value	TCR (ppm/°C)
PV01□504C01	0.25(85°C)	Reflow/Soldering Iron	12	500k ohm ±10%	±150
PV01□105C01	0.25(85°C)	Reflow/Soldering Iron	12	1M ohm ±10%	±150

Operating Temperature Range: -55 to 125 °C

The blank column is filled with the code of adjustment direction P (side), W (top) or X (side).

Magazine packaging is standard for PV01 series.

Construction

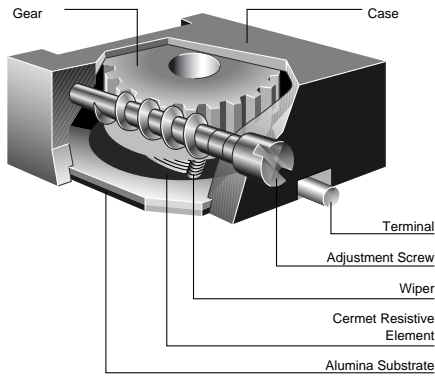

Standard Land Pattern

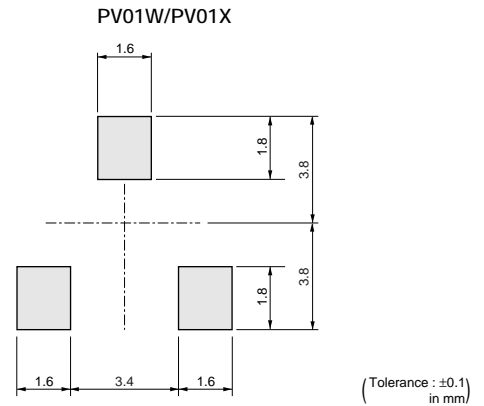
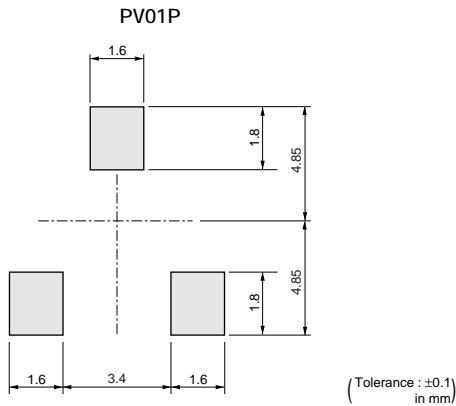

Characteristics

Temperature Cycle	ΔTR	±1%
	ΔV.S.S.	±1%
Humidity	ΔTR	±2%
	IR	100M ohm min.
Vibration (20G)	ΔTR	±1%
	ΔV.S.S.	±1%
Shock (100G)	ΔTR	±1%
	ΔV.S.S.	±1%
Temperature Load Life	ΔTR	±2%
	ΔV.S.S.	±1%
Low Temperature Exposure	ΔTR	±1%
	ΔV.S.S.	±1%
High Temperature Exposure	ΔTR	±2%
	ΔV.S.S.	±1%
Rotational Life (200 cycles)	ΔTR	R≤100 ohm ... ±3%
		R>100 ohm ... ±2%

ΔTR : Total Resistance Change

ΔV.S.S. : Voltage Setting Stability

IR : Insulation Resistance

R : Standard Total Resistance

PVG5/PV01 Series Notice

■ Notice (Operating and Storage Conditions)

1. Store in temperatures of -10 to +40 deg. C and relative humidity of 30-85%RH.
2. Do not store in or near corrosive gases.
3. Use within six months after delivery.
4. Open the package just before using.
5. Do not store under direct sunlight.
6. If you use the trimmer potentiometer in an environment other than listed below, please consult with a Murata factory representative prior to using.
The trimmer potentiometer should not be used under the following environmental conditions:

- (1) Corrosive gaseous atmosphere
(Ex. Chlorine gas, Hydrogen sulfide gas, Ammonia gas, Sulfuric acid gas, Nitric oxide gas, etc.)
- (2) In liquid
(Ex. Oil, Medical liquid, Organic solvent, etc.)
- (3) Dusty/dirty atmosphere
- (4) Direct sunlight
- (5) Static voltage nor electric/magnetic fields
- (6) Direct sea breeze
- (7) Other variations of the above

■ Notice (Rating)

1. When using with partial load (rheostat), minimize the power depending on the resistance value.
2. The maximum input voltage to a trimmer potentiometer should not exceed $(P \cdot R)^{1/2}$ or the maximum operating voltage, whichever is smaller.
3. The maximum input current to a trimmer potentiometer should not exceed $(P/R)^{1/2}$ or the allowable wiper current, whichever is smaller.

■ Notice (Soldering and Mounting)

1. Soldering
 - (1) Soldering condition
Refer to the temperature profile.
If the soldering conditions are not suitable, e.g., excessive time and/or excessive temperature, the trimmer capacitor may deviate from the specified characteristics.
 - (2) Cannot be soldered using the flow soldering method. If you use the flow soldering method, the trimmer potentiometer may not function.
 - (3) The soldering iron should not come in contact with the case of the trimmer potentiometer. If such contact does occur, the trimmer potentiometer may be damaged.
 - (4) Insufficient amounts of solder can lead to insufficient soldering strength on PCB.
Excessive amounts of solder may cause bridging between the terminals.
2. Mounting
 - (1) Use our standard land dimension. Excessive land area causes displacement due to the effect of the surface tension of the solder. Insufficient land area leads to insufficient soldering strength of the chip.
 - (2) Do not apply excessive force (preferably 9.8N (Ref.: 1kgf) max.), when the trimmer potentiometer is mounted to the PCB.
 - (3) Do not warp and/or bend PC board to prevent trimmer potentiometer from breakage.

- (4) In chip placers, the recommended size of the cylindrical pick-up nozzle should be outer dimension 4.0mm dia. and inner dimension 2.0mm dia.
3. Cleaning
 - (1) Isopropyl-alcohol and Ethyl-alcohol are applicable solvents for cleaning. If you use any other types of solvents, please consult with a Murata factory representative prior to using.
 - (2) The total cleaning time by cold dipping, vapor and ultrasonic washing (conditions as below) method should be less than 3 minutes.
 - (3) For ultra-sonic cleaning, the available condition is as follows.
 - >Power: 600W (67 liter) max.
 - >Frequency: 28kHz
 - >Temperature: Ambient temperatureDue to the ultra-sonic cleaning equipment's peculiar self-resonance point and that the cleaning compatibility usually depends on the jig construction and/or the cleaning condition such as the depth of immersion, please check the cleaning equipment to determine the suitable conditions.

If the trimmer potentiometer is cleaned by other conditions, the trimmer potentiometer may be damaged.

PVG5/PV01 Series Notice

■ Soldering Profile

● Reflow Soldering Profile

1. Soldering profile for Lead-free solder (96.5Sn/3.0Ag/0.5Cu)

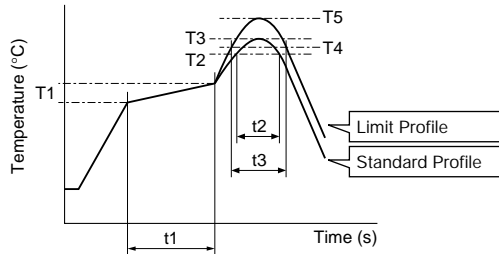

Series	Standard Profile						Limit Profile					
	Pre-heating		Heating		Peak Temperature (T3)	Cycle of Reflow	Pre-heating		Heating		Peak Temperature (T5)	Cycle of Reflow
	Temp. (T1)	Time (t1)	Temp. (T2)	Time (t2)			Temp. (T1)	Time (t1)	Temp. (T4)	Time (t3)		
°C	sec.	°C	sec.	°C	Time	°C	sec.	°C	sec.	°C	Time	
PVG5	150 to 180	60 to 120	220	30 to 60	245±3	2	150 to 180	60 to 120	230	30 to 50	260 +5/-0	2
PV01	150 to 180	60 to 120	220	30 to 60	245±3	2	150 to 180	60 to 120	220	30 to 60	260	2

2. Soldering profile for Eutectic solder (63Sn/37Pb)

(Limit profile: refer to 1)

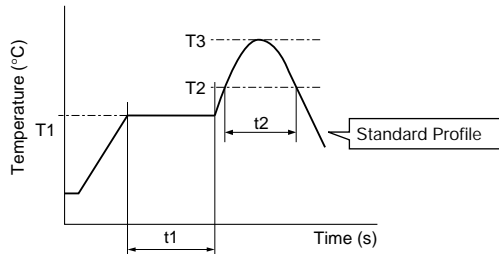

Series	Standard Profile					
	Pre-heating		Heating		Peak Temperature (T3)	Cycle of Reflow
	Temp. (T1)	Time (t1)	Temp. (T2)	Time (t2)		
°C	sec.	°C	sec.	°C	Time	
PVG5, PV01	150	60 to 120	183	30	230	1

● Soldering Iron

Series	Standard Condition			
	Temperature of Soldering Iron Tip	Soldering Time	Soldering Iron Power Output	Cycle of Soldering Iron
	°C	sec.	W	Time
PVG5, PV01	350±10	3 max.	30 max.	1

■ Notice (Handling)

- Use suitable screwdrivers that fit comfortably in driver slot. We recommend the screwdrivers below.
 * Recommended screwdrivers for manual adjustment
 <PVG5 series>
 VESSEL MFG.: NO.9000-1.3x30
 (Murata P/N: KMDR130)
 <PV01 series>
 ENGINEER INC.: DA-40
 (Murata P/N: KMDR180)
 We can supply the screwdrivers above.
 If you place order, please specify Murata P/N.

- Don't apply more than 9.8N (Ref.; 1kgf) of twist and stress after mounting onto PCB to prevent contact intermittence. If excessive force is applied, the trimmer potentiometer may not function.
- When adjusting with a screwdriver, do not apply excessive force (preferable 4.9N (Ref; 500gf) max.)
- When using a lock paint to fix slot position, please use adhesive resin without chlorine or sulfur (Three-bond "1401 series") and evaluate performance by your products. Lock paint may cause corrosion or electrical problems.

■ Notice (Other)

- Please make sure that your product has been evaluated and confirmed against your specifications when our product is mounted to your product.
- Murata cannot guarantee trimmer potentiometer integrity when used under conditions other than those specified in this document.

Trimmer Potentiometers



Lead Sealed Type Single-turn PVC6/PV32/PV34 Series

PVC6 Series

■ Features

1. Enlarged and colored rotor provides superior adjustability.
2. Cone-shaped rotor improves driver insertion during automatic adjustment.
3. Available for "Zero" plus adjustment tool (taper head) use
4. Easy to see 11-scales adjustment positions.
5. Sealed construction protects the interior from dust and liquid, which achieves stable performance.
6. Available for ultrasonic cleaning after soldering
7. During cutting process by the inserter machine, the round shaped lead wire prevents clinch problems and realizes longer life of cutter than flat shaped lead wire.
8. Flammability: UL94V-0
9. To be complied with RoHS directive by new Cd free cermet resistive material. Pb free terminals with Sn plating.

■ Applications

- | | |
|-----------------|-------------------------|
| 1. DY | 2. CRT display |
| 3. Power supply | 4. Professional cameras |
| 5. CATV | 6. FAX |
| 7. Printers | 8. OA Equipment |
| 9. Sensors | |

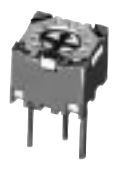

PVC6A

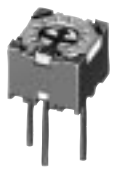
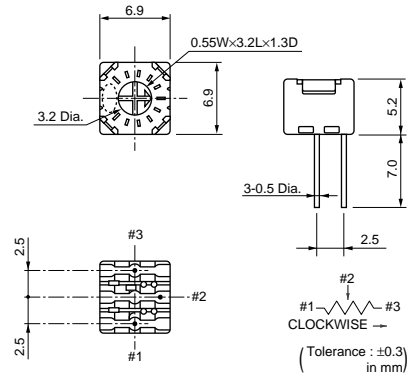

PVC6D

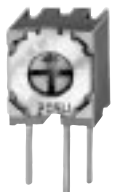
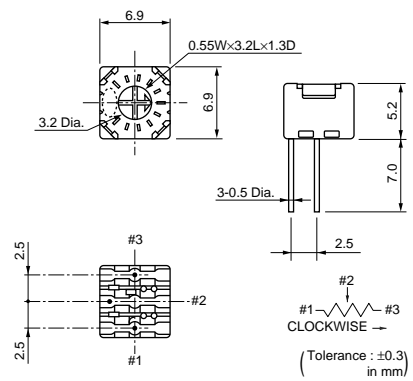

PVC6E

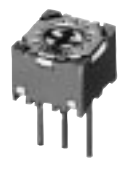
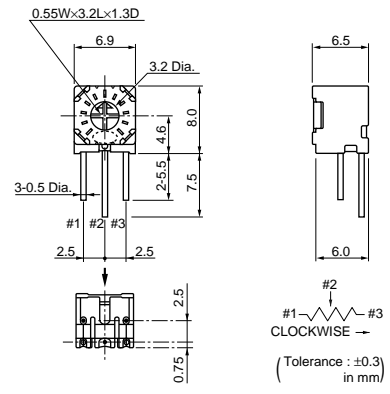

PVC6M

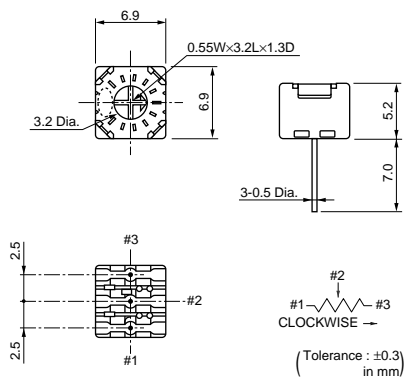

PVC6H

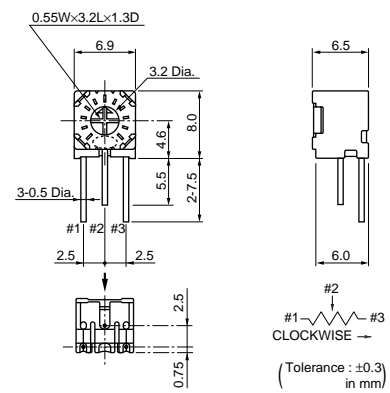

Continued from the preceding page.

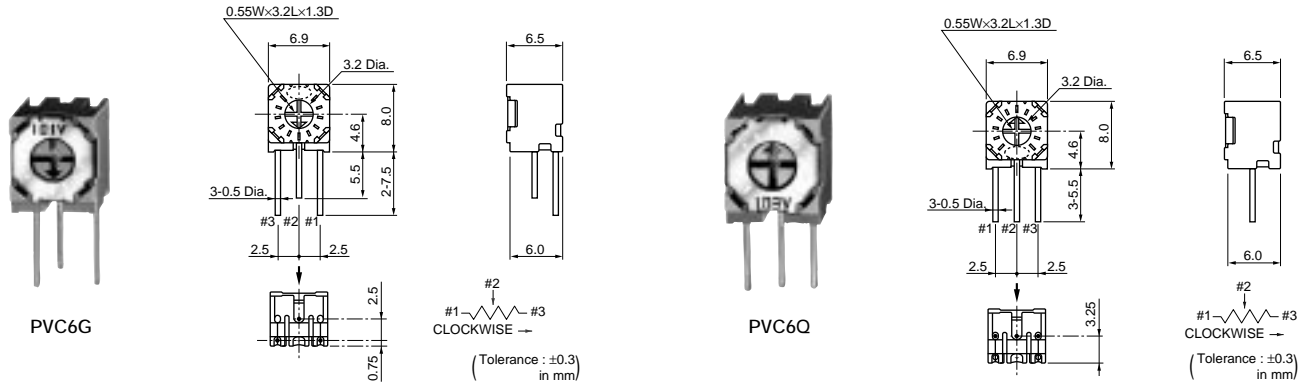

Part Number	Power Rating (W)	Soldering Method	Number of Turns (Effective Rotation Angle)	Total Resistance Value	TCR (ppm/°C)
PVC6□100C01	0.5(70°C)	Flow/Soldering Iron	1(240°±5°)	10ohm ±10%	±100
PVC6□200C01	0.5(70°C)	Flow/Soldering Iron	1(240°±5°)	20ohm ±10%	±100
PVC6□250C01	0.5(70°C)	Flow/Soldering Iron	1(240°±5°)	25ohm ±10%	±100
PVC6□500C01	0.5(70°C)	Flow/Soldering Iron	1(240°±5°)	50ohm ±10%	±100
PVC6□101C01	0.5(70°C)	Flow/Soldering Iron	1(240°±5°)	100ohm ±10%	±100
PVC6□201C01	0.5(70°C)	Flow/Soldering Iron	1(240°±5°)	200ohm ±10%	±100
PVC6□251C01	0.5(70°C)	Flow/Soldering Iron	1(240°±5°)	250ohm ±10%	±100
PVC6□501C01	0.5(70°C)	Flow/Soldering Iron	1(240°±5°)	500ohm ±10%	±100
PVC6□102C01	0.5(70°C)	Flow/Soldering Iron	1(240°±5°)	1k ohm ±10%	±100
PVC6□202C01	0.5(70°C)	Flow/Soldering Iron	1(240°±5°)	2k ohm ±10%	±100
PVC6□252C01	0.5(70°C)	Flow/Soldering Iron	1(240°±5°)	2.5k ohm ±10%	±100
PVC6□502C01	0.5(70°C)	Flow/Soldering Iron	1(240°±5°)	5k ohm ±10%	±100
PVC6□103C01	0.5(70°C)	Flow/Soldering Iron	1(240°±5°)	10k ohm ±10%	±100
PVC6□203C01	0.5(70°C)	Flow/Soldering Iron	1(240°±5°)	20k ohm ±10%	±100
PVC6□253C01	0.5(70°C)	Flow/Soldering Iron	1(240°±5°)	25k ohm ±10%	±100
PVC6□503C01	0.5(70°C)	Flow/Soldering Iron	1(240°±5°)	50k ohm ±10%	±100
PVC6□104C01	0.5(70°C)	Flow/Soldering Iron	1(240°±5°)	100k ohm ±10%	±100
PVC6□204C01	0.5(70°C)	Flow/Soldering Iron	1(240°±5°)	200k ohm ±10%	±100
PVC6□254C01	0.5(70°C)	Flow/Soldering Iron	1(240°±5°)	250k ohm ±10%	±100
PVC6□504C01	0.5(70°C)	Flow/Soldering Iron	1(240°±5°)	500k ohm ±10%	±100
PVC6□105C01	0.5(70°C)	Flow/Soldering Iron	1(240°±5°)	1M ohm ±10%	±100
PVC6□205C01	0.5(70°C)	Flow/Soldering Iron	1(240°±5°)	2M ohm ±10%	±100
PVC6□505C01	0.5(70°C)	Flow/Soldering Iron	1(240°±5°)	5M ohm ±10%	±100
PVC6□100C04	0.5(70°C)	Flow/Soldering Iron	1(240°±5°)	10ohm ±10%	±100
PVC6□200C04	0.5(70°C)	Flow/Soldering Iron	1(240°±5°)	20ohm ±10%	±100
PVC6□250C04	0.5(70°C)	Flow/Soldering Iron	1(240°±5°)	25ohm ±10%	±100
PVC6□500C04	0.5(70°C)	Flow/Soldering Iron	1(240°±5°)	50ohm ±10%	±100
PVC6□101C04	0.5(70°C)	Flow/Soldering Iron	1(240°±5°)	100ohm ±10%	±100
PVC6□201C04	0.5(70°C)	Flow/Soldering Iron	1(240°±5°)	200ohm ±10%	±100
PVC6□251C04	0.5(70°C)	Flow/Soldering Iron	1(240°±5°)	250ohm ±10%	±100
PVC6□501C04	0.5(70°C)	Flow/Soldering Iron	1(240°±5°)	500ohm ±10%	±100
PVC6□102C04	0.5(70°C)	Flow/Soldering Iron	1(240°±5°)	1k ohm ±10%	±100
PVC6□202C04	0.5(70°C)	Flow/Soldering Iron	1(240°±5°)	2k ohm ±10%	±100
PVC6□252C04	0.5(70°C)	Flow/Soldering Iron	1(240°±5°)	2.5k ohm ±10%	±100
PVC6□502C04	0.5(70°C)	Flow/Soldering Iron	1(240°±5°)	5k ohm ±10%	±100
PVC6□103C04	0.5(70°C)	Flow/Soldering Iron	1(240°±5°)	10k ohm ±10%	±100
PVC6□203C04	0.5(70°C)	Flow/Soldering Iron	1(240°±5°)	20k ohm ±10%	±100
PVC6□253C04	0.5(70°C)	Flow/Soldering Iron	1(240°±5°)	25k ohm ±10%	±100
PVC6□503C04	0.5(70°C)	Flow/Soldering Iron	1(240°±5°)	50k ohm ±10%	±100
PVC6□104C04	0.5(70°C)	Flow/Soldering Iron	1(240°±5°)	100k ohm ±10%	±100
PVC6□204C04	0.5(70°C)	Flow/Soldering Iron	1(240°±5°)	200k ohm ±10%	±100
PVC6□254C04	0.5(70°C)	Flow/Soldering Iron	1(240°±5°)	250k ohm ±10%	±100
PVC6□504C04	0.5(70°C)	Flow/Soldering Iron	1(240°±5°)	500k ohm ±10%	±100
PVC6□105C04	0.5(70°C)	Flow/Soldering Iron	1(240°±5°)	1M ohm ±10%	±100

Continued on the following page. ↗

Continued from the preceding page.

Part Number	Power Rating (W)	Soldering Method	Number of Turns (Effective Rotation Angle)	Total Resistance Value	TCR (ppm/°C)
PVC6□205C04	0.5(70°C)	Flow/Soldering Iron	1(240°±5°)	2M ohm ±10%	±100
PVC6□505C04	0.5(70°C)	Flow/Soldering Iron	1(240°±5°)	5M ohm ±10%	±100

Operating Temperature Range: -55 to 125 °C

The blank column is filled with the code of adjustment direction and lead type (A, D, E, G, H, M and Q).

The order quantity should be an integral multiple of the "Minimum Quantity" .

The last three digits express the individual specification codes. C01 for standard type and C04 for radial taping type (PVC6M/PVC6Q series only).

Construction

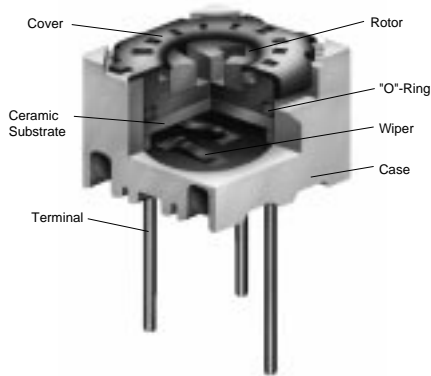

Standard Mounting Holes

PVC6A/PVC6E

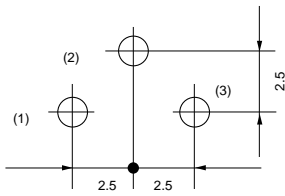

(Tolerance: ±0.1 in mm)

PVC6D/PVC6H

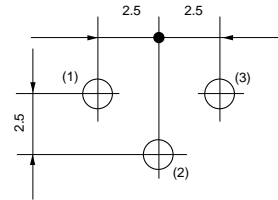

(Tolerance: ±0.1 in mm)

PVC6M/PVC6Q

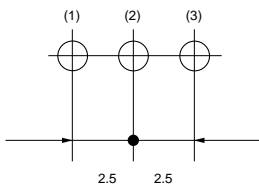

(Tolerance: ±0.1 in mm)

PVC6G

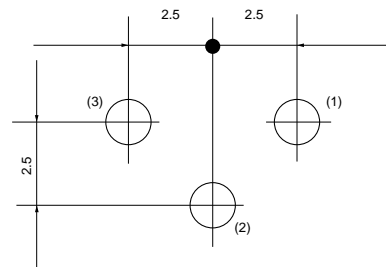

(Tolerance: ±0.1 in mm)

Continued on the following page. ↗

 Continued from the preceding page.

■ Characteristics

Temperature Cycle	ΔTR	$\pm 2\%$
	$\Delta V.S.S.$	$\pm 1\%$
Humidity	ΔTR	$\pm 2\%$
	$\Delta V.S.S.$	$\pm 1\%$
	IR	100Mohm min.
Vibration (20G)	ΔTR	$\pm 1\%$
	$\Delta V.S.S.$	$\pm 1\%$
Shock (100G)	ΔTR	$\pm 1\%$
	$\Delta V.S.S.$	$\pm 1\%$
Temperature Load Life	ΔTR	$\pm 2\%$
	$\Delta V.S.S.$	$\pm 2\%$
Low Temperature Exposure	ΔTR	$\pm 2\%$
	$\Delta V.S.S.$	$\pm 1\%$
High Temperature Exposure	ΔTR	$\pm 2\%$
	$\Delta V.S.S.$	$\pm 1\%$
Rotational Life (200 cycles)	ΔTR	$\pm 4\%$

ΔTR : Total Resistance Change
 $\Delta V.S.S.$: Voltage Setting Stability
 IR : Insulation Resistance

PV32 Series

■ Features

1. 6 standard terminal styles
2. Round shaped body enables smaller area mount than same 6mm square potentiometer.
3. Sealed construction protects the interior from dust and liquid, which achieves stable performance.
4. Available for ultrasonic cleaning after soldering
5. Flammability: UL94V-0

■ Applications

1. HDTVs
2. Professional cameras
3. CATV
4. FAX
5. Printers
6. Sensors
7. Power supply



PV32H

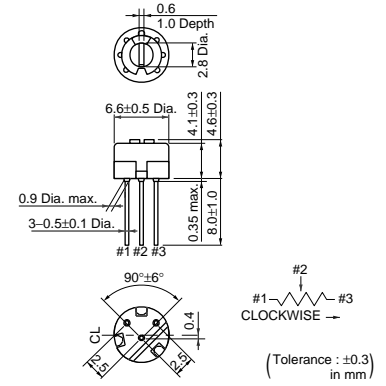

PV32R

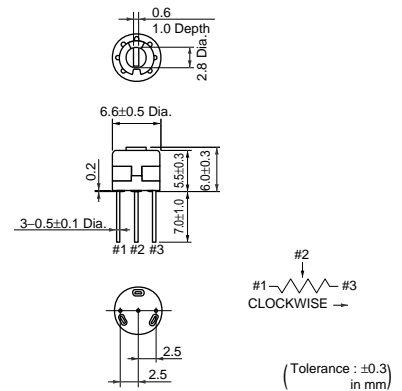

PV32P

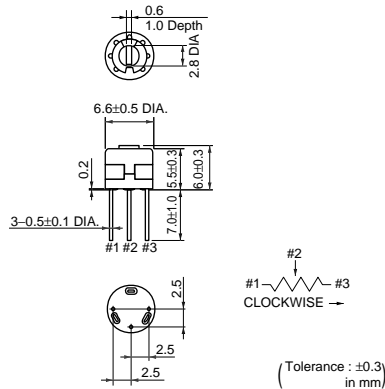

PV32N

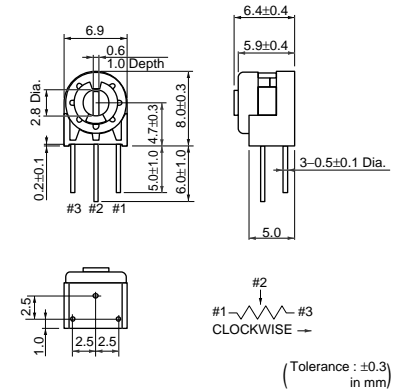

PV32S

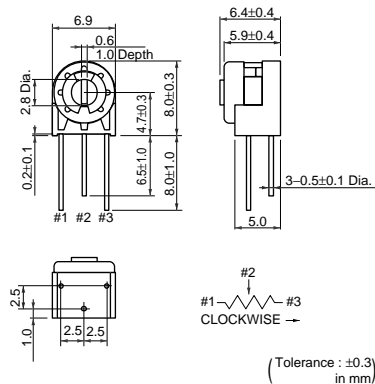

PV32T

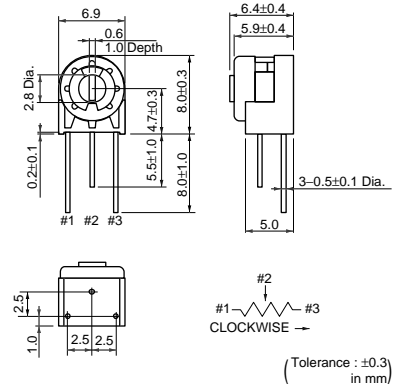

Part Number	Power Rating (W)	Soldering Method	Number of Turns (Effective Rotation Angle)	Total Resistance Value	TCR (ppm/°C)
PV32□100A01	0.5(70°C)	Flow/Soldering Iron	1(230°±5°)	10ohm ±20%	±100
PV32□200A01	0.5(70°C)	Flow/Soldering Iron	1(230°±5°)	20ohm ±20%	±100
PV32□250A01	0.5(70°C)	Flow/Soldering Iron	1(230°±5°)	25ohm ±20%	±100

Continued on the following page. ↗

Continued from the preceding page.

Part Number	Power Rating (W)	Soldering Method	Number of Turns (Effective Rotation Angle)	Total Resistance Value	TCR (ppm/°C)
PV32□500A01	0.5(70°C)	Flow/Soldering Iron	1(230°±5°)	50ohm ±20%	±100
PV32□101A01	0.5(70°C)	Flow/Soldering Iron	1(230°±5°)	100ohm ±20%	±100
PV32□201A01	0.5(70°C)	Flow/Soldering Iron	1(230°±5°)	200ohm ±20%	±100
PV32□251A01	0.5(70°C)	Flow/Soldering Iron	1(230°±5°)	250ohm ±20%	±100
PV32□501A01	0.5(70°C)	Flow/Soldering Iron	1(230°±5°)	500ohm ±20%	±100
PV32□102A01	0.5(70°C)	Flow/Soldering Iron	1(230°±5°)	1k ohm ±20%	±100
PV32□202A01	0.5(70°C)	Flow/Soldering Iron	1(230°±5°)	2k ohm ±20%	±100
PV32□252A01	0.5(70°C)	Flow/Soldering Iron	1(230°±5°)	2.5k ohm ±20%	±100
PV32□502A01	0.5(70°C)	Flow/Soldering Iron	1(230°±5°)	5k ohm ±20%	±100
PV32□103A01	0.5(70°C)	Flow/Soldering Iron	1(230°±5°)	10k ohm ±20%	±100
PV32□203A01	0.5(70°C)	Flow/Soldering Iron	1(230°±5°)	20k ohm ±20%	±100
PV32□253A01	0.5(70°C)	Flow/Soldering Iron	1(230°±5°)	25k ohm ±20%	±100
PV32□503A01	0.5(70°C)	Flow/Soldering Iron	1(230°±5°)	50k ohm ±20%	±100
PV32□104A01	0.5(70°C)	Flow/Soldering Iron	1(230°±5°)	100k ohm ±20%	±100
PV32□204A01	0.5(70°C)	Flow/Soldering Iron	1(230°±5°)	200k ohm ±20%	±100
PV32□254A01	0.5(70°C)	Flow/Soldering Iron	1(230°±5°)	250k ohm ±20%	±100
PV32□504A01	0.5(70°C)	Flow/Soldering Iron	1(230°±5°)	500k ohm ±20%	±100
PV32□105A01	0.5(70°C)	Flow/Soldering Iron	1(230°±5°)	1M ohm ±20%	±100
PV32□205A01	0.5(70°C)	Flow/Soldering Iron	1(230°±5°)	2M ohm ±20%	±100
PV32□505A01	0.5(70°C)	Flow/Soldering Iron	1(230°±5°)	5M ohm ±20%	±100

Operating Temperature Range: -55 to 125 °C

The blank column is filled with the code of adjustment direction and lead type (H, P, R, N, S and T).

The order quantity should be an integral multiple of the "Minimum Quantity".

Construction

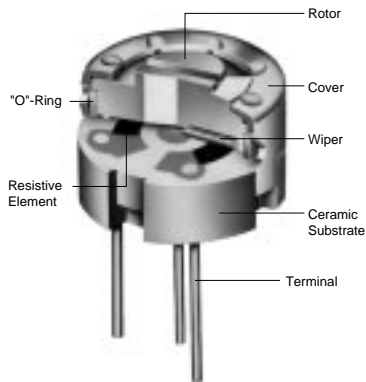

Standard Mounting Holes

PV32H

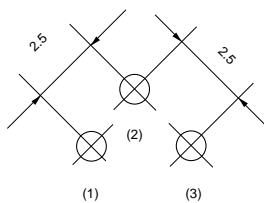

(Tolerance: ±0.1 in mm)

PV32R

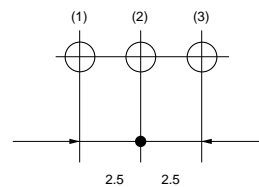

(Tolerance: ±0.1 in mm)

Continued on the following page. ↗

Continued from the preceding page.

Standard Mounting Holes

PV32P/PV32S

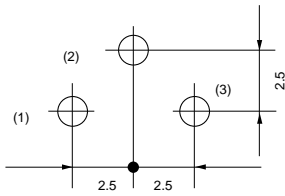

(Tolerance: ±0.1
in mm)

PV32N

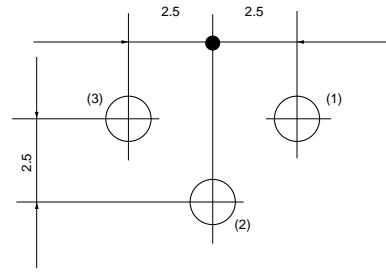

(Tolerance: ±0.1
in mm)

PV32T

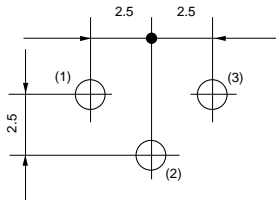

(Tolerance: ±0.1
in mm)

Characteristics

Temperature Cycle	ΔTR	±2%
	ΔV.S.S.	±1%
Humidity	ΔTR	±2%
	IR	100M ohm min.
Vibration (20G)	ΔTR	±1%
	ΔV.S.S.	±1%
Shock (100G)	ΔTR	±1%
	ΔV.S.S.	±1%
Temperature Load Life	ΔTR	±2%
	ΔV.S.S.	±2%
Low Temperature Exposure	ΔTR	±2%
	ΔV.S.S.	±1%
High Temperature Exposure	ΔTR	±2%
	ΔV.S.S.	±1%
Rotational Life (200 cycles)	ΔTR	±4%

ΔTR : Total Resistance Change
 ΔV.S.S. : Voltage Setting Stability
 IR : Insulation Resistance

PV34 Series

■ Features

1. 5 standard terminal styles
2. Sealed construction protects the interior from dust and liquid, which achieves stable performance.
3. Available for ultrasonic cleaning after soldering
4. Flammability: UL94V-0
5. To be complied with RoHS directive by new Cd free cermet resistive material. Pb free terminals with Sn plating.

■ Applications

- | | |
|------------|-----------------------------|
| 1. HDTVs | 2. Professional cameras |
| 3. CATV | 4. Printers |
| 5. Sensors | 6. Switching power supplies |



PV34F

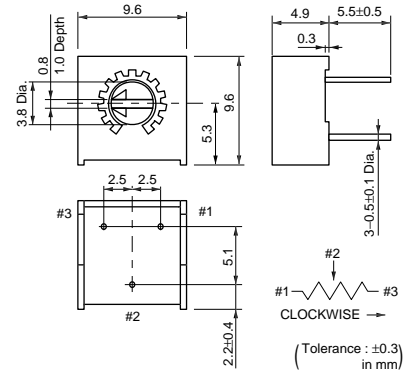

PV34H

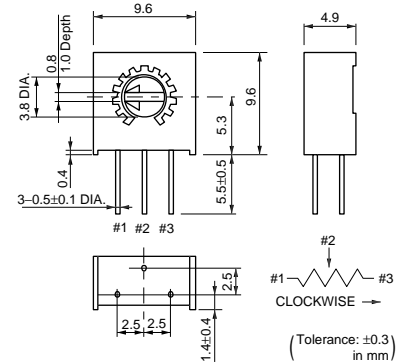

PV34P

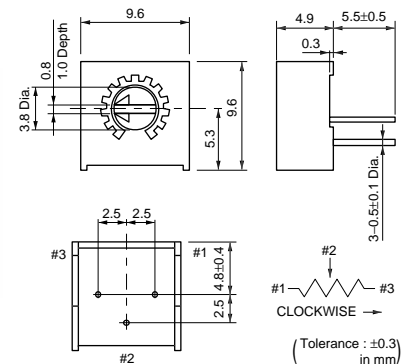

PV34W

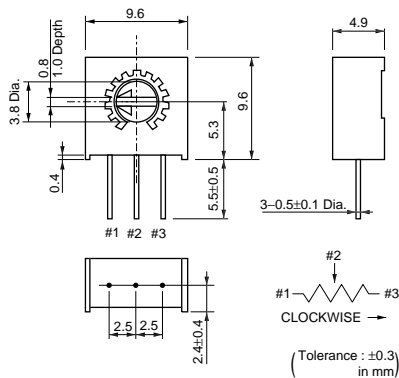

PV34X

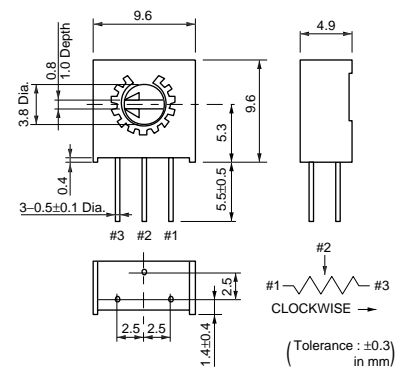

Part Number	Power Rating (W)	Soldering Method	Number of Turns (Effective Rotation Angle)	Total Resistance Value	TCR (ppm/°C)
PV34□100C01	0.5(70°C)	Flow/Soldering Iron	1(280°±15°)	10ohm ±10%	±150
PV34□200C01	0.5(70°C)	Flow/Soldering Iron	1(280°±15°)	20ohm ±10%	±150
PV34□500C01	0.5(70°C)	Flow/Soldering Iron	1(280°±15°)	50ohm ±10%	±150
PV34□101C01	0.5(70°C)	Flow/Soldering Iron	1(280°±15°)	100ohm ±10%	±150
PV34□201C01	0.5(70°C)	Flow/Soldering Iron	1(280°±15°)	200ohm ±10%	±100
PV34□501C01	0.5(70°C)	Flow/Soldering Iron	1(280°±15°)	500ohm ±10%	±100
PV34□102C01	0.5(70°C)	Flow/Soldering Iron	1(280°±15°)	1k ohm ±10%	±100
PV34□202C01	0.5(70°C)	Flow/Soldering Iron	1(280°±15°)	2k ohm ±10%	±100
PV34□502C01	0.5(70°C)	Flow/Soldering Iron	1(280°±15°)	5k ohm ±10%	±100
PV34□103C01	0.5(70°C)	Flow/Soldering Iron	1(280°±15°)	10k ohm ±10%	±100
PV34□203C01	0.5(70°C)	Flow/Soldering Iron	1(280°±15°)	20k ohm ±10%	±100
PV34□253C01	0.5(70°C)	Flow/Soldering Iron	1(280°±15°)	25k ohm ±10%	±100
PV34□503C01	0.5(70°C)	Flow/Soldering Iron	1(280°±15°)	50k ohm ±10%	±100
PV34□104C01	0.5(70°C)	Flow/Soldering Iron	1(280°±15°)	100k ohm ±10%	±100
PV34□204C01	0.5(70°C)	Flow/Soldering Iron	1(280°±15°)	200k ohm ±10%	±100
PV34□254C01	0.5(70°C)	Flow/Soldering Iron	1(280°±15°)	250k ohm ±10%	±100
PV34□504C01	0.5(70°C)	Flow/Soldering Iron	1(280°±15°)	500k ohm ±10%	±100
PV34□105C01	0.5(70°C)	Flow/Soldering Iron	1(280°±15°)	1M ohm ±10%	±100
PV34□205C01	0.5(70°C)	Flow/Soldering Iron	1(280°±15°)	2M ohm ±10%	±100

Operating Temperature Range: -55 to 125 °C

The blank column is filled with the code of adjustment direction and lead type (F, H, P, X and W).

The order quantity should be an integral multiple of the "Minimum Quantity".

Construction

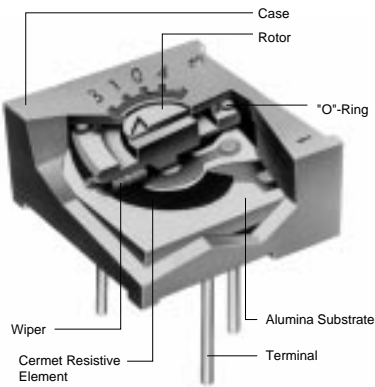

7

Standard Mounting Holes

PV34F

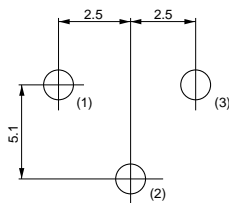

(Tolerance: ±0.1 in mm)

PV34H/PV34P

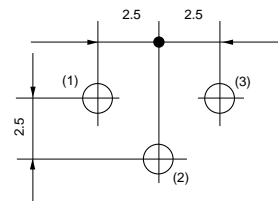

(Tolerance: ±0.1 in mm)

Continued on the following page. ↗

Continued from the preceding page.

Standard Mounting Holes

PV34W

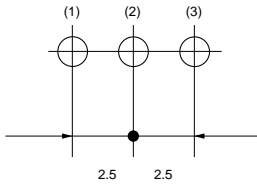

(Tolerance: ±0.1
in mm)

PV34X

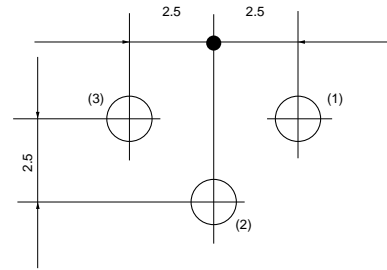

(Tolerance: ±0.1
in mm)

Characteristics

Temperature Cycle	ΔTR	±2%
	ΔV.S.S.	±1%
Humidity	ΔTR	±2%
	IR	100M ohm min.
Vibration (20G)	ΔTR	±1%
	ΔV.S.S.	±1%
Shock (100G)	ΔTR	±1%
	ΔV.S.S.	±1%
Temperature Load Life	ΔTR	±2%
	ΔV.S.S.	±2%
Low Temperature Exposure	ΔTR	±1%
	ΔV.S.S.	±1%
High Temperature Exposure	ΔTR	±2%
	ΔV.S.S.	±1%
Rotational Life (200 cycles)	ΔTR	R ≤ 100k ohm ... ±3%
		R > 100k ohm ... ±5%

ΔTR : Total Resistance Change
 ΔV.S.S. : Voltage Setting Stability
 IR : Insulation Resistance
 R : Standard Total Resistance

PVC6/PV32/PV34 Series Notice

■ Notice (Operating and Storage Conditions)

1. Store in temperatures of -10 to +40 deg. C and relative humidity of 30-85%RH.
2. Do not store in or near corrosive gases.
3. Use within six months after delivery.
4. Open the package just before using.
5. Do not store under direct sunlight.
6. If you use the trimmer potentiometer in an environment other than listed below, please consult with a Murata factory representative prior to using.
The trimmer potentiometer should not be used under the following environmental conditions:

- (1) Corrosive gaseous atmosphere
(Ex. Chlorine gas, Hydrogen sulfide gas, Ammonia gas, Sulfuric acid gas, Nitric oxide gas, etc.)
- (2) In liquid
(Ex. Oil, Medical liquid, Organic solvent, etc.)
- (3) Dusty/dirty atmosphere
- (4) Direct sunlight
- (5) Static voltage nor electric/magnetic fields
- (6) Direct sea breeze
- (7) Other variations of the above

■ Notice (Rating)

1. When using with partial load (rheostat), minimize the power depending on the resistance value.
2. The maximum input voltage to a trimmer potentiometer should not exceed $(P \cdot R)^{1/2}$ or the maximum operating voltage, whichever is smaller.
3. The maximum input current to a trimmer potentiometer should not exceed $(P/R)^{1/2}$ or the allowable wiper current, whichever is smaller.

■ Notice (Soldering and Mounting)

1. Soldering
 - (1) Soldering condition
Refer to the temperature profile.
If the soldering conditions are not suitable, e.g., excessive time and/or excessive temperature, the trimmer potentiometer may deviate from the specified characteristics.
 - (2) To minimize mechanical stress when adjusting, the trimmer potentiometer should be mounted onto PCB without gap.
 - (3) The soldering iron should not come in contact with the case of the trimmer potentiometer. If such contact does occur, the trimmer potentiometer may be damaged.
2. Mounting
 - (1) Use PCB hole to meet the pin of the trimmer potentiometer. If the trimmer potentiometer installs into insufficient PCB hole, the trimmer potentiometer may be damaged by mechanical stress.
 - (2) Do not apply excessive force (preferably 9.8N (Ref.; 1kgf) max.), when the trimmer potentiometer is mounted to the PCB.

3. Cleaning
 - (1) Isopropyl-alcohol and Ethyl-alcohol are applicable solvents for cleaning. If you use any other types of solvents, please consult with a Murata factory representative prior to using.
 - (2) The total cleaning time by cold dipping, vapor and ultrasonic washing (conditions as below) method should be less than 3 minutes.
 - (3) For ultra-sonic cleaning, the available condition is as follows.
 - >Power: 600W (67 liter) max.
 - >Frequency: 28kHz
 - >Temperature: Ambient temperatureDue to the ultra-sonic cleaning equipment's peculiar self-resonance point and that the cleaning compatibility usually depends on the jig construction and/or the cleaning condition such as the depth of immersion, please check the cleaning equipment to determine the suitable conditions.
- If the trimmer potentiometer is cleaned by other conditions, the trimmer potentiometer may be damaged.

PVC6/PV32/PV34 Series Notice

■ Soldering Profile ● Flow Soldering Profile

Soldering profile for Lead-free solder (96.5Sn/3.0Ag/0.5Cu), Eutectic solder (63Sn/37Pb)

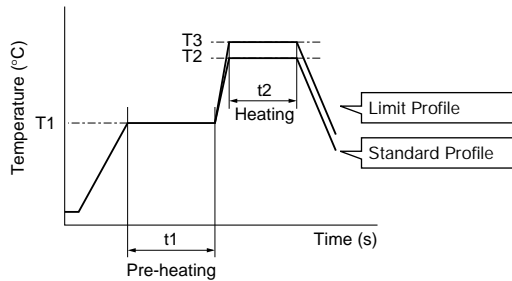

Standard Profile				
Pre-heating		Heating		Cycle of Flow
Temp. (T1)	Time (t1)	Temp. (T2)	Time (t2)	
°C	sec.	°C	sec.	Time
150	60 to 120	250	5 max.	1

Limit Profile				
Pre-heating		Heating		Cycle of Flow
Temp. (T1)	Time (t1)	Temp. (T3)	Time (t2)	
°C	sec.	°C	sec.	Time
150	60 to 120	260	3 max.	1

● Soldering Iron

Standard Condition			
Temperature of Soldering Iron Tip	Soldering Time	Soldering Iron Power Output	Cycle of Soldering Iron
°C	sec.	W	Time
350±10	3 max.	30 max.	1

■ Notice (Handling)

- Use suitable screwdrivers that fit comfortably in driver slot. We recommend the screwdrivers below.
 - * Recommended screwdriver for manual adjustment
 - <PVC6 series>
 - VESSEL MFG.: NO.9000+0x30 (Murata P/N: KMDR150)
 - TORAY INDUSTRIES, INC.: SA-2225 (Murata P/N: KMDR070)
 - <PV32/34 series>
 - ENGINEER INC.: DA-40 (Murata P/N: KMDR180)
 - * Recommended screwdriver bit for automatic adjustment
 - <PVC6 series>
 - VESSEL MFG.: NO.CA-10 (Murata P/N: KMBT090)
 - TORAY INDUSTRIES, INC.: JB-2225 (Murata P/N: KMBT070)
- We can supply the screwdrivers above.
 If you place an order, please specify the Murata P/N.

- Don't apply more than 9.8N (Ref.; 1kgf) of twist and stress after mounting onto PCB to prevent contact intermittence. If excessive force is applied, the trimmer potentiometer may not function.
- When adjusting with an adjustment tool, the applied force to the adjustment screw should not exceed 4.9N (Ref.; 500gf). If excessive force is applied, the trimmer potentiometer may not function due to damage.
- The rotational torque at the position of the adjustment range should not exceed the stop strength.
- When using a lock paint to fix slot position, please use adhesive resin without chlorine or sulfur (Three-bond "1401 series") and evaluate performance by your products. Lock paint may cause corrosion or electrical contact problems.

■ Notice (Other)

- Please make sure that your product has been evaluated and confirmed against your specifications when our product is mounted to your product.
- Murata cannot guarantee trimmer potentiometer integrity when used under conditions other than those specified in this document.

Trimmer Potentiometers



Lead Sealed Type Multi-turns PV12/PV37/PV23/PV22/PV36 Series

PV12 Series

■ Features

1. The unique inner gear system recognizes the position of the center of the shaft of the potentiometer.
2. Sealed construction protects the interior from dust and liquid, which achieves stable performance.
3. Available for ultrasonic cleaning after soldering
4. Clutch mechanism prevents excessive wiper rotation.

■ Applications

1. HDTVs
2. Professional cameras
3. CATV
4. FAX
5. Printers
6. Sensors
7. Switching power supplies



PV12H

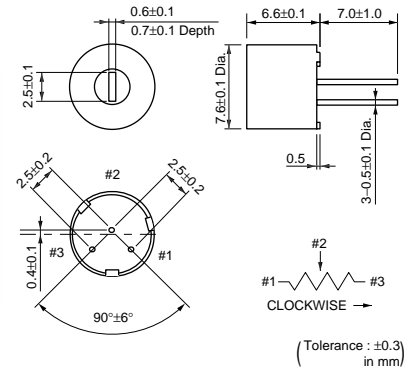

PV12P

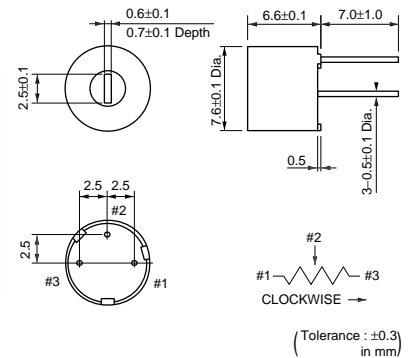

PV12S

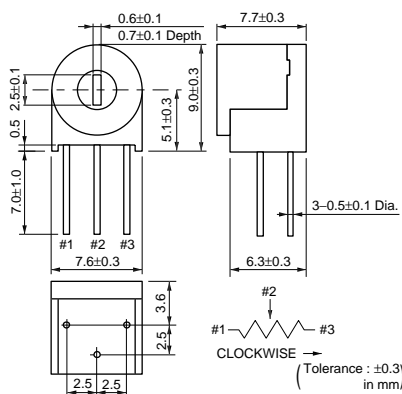

PV12T

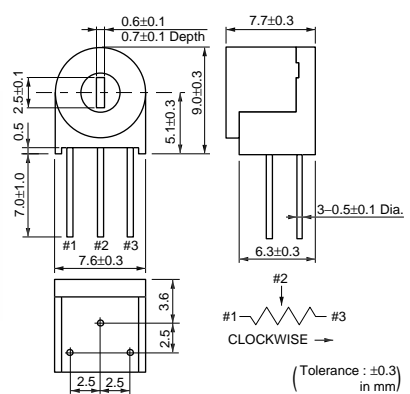

Part Number	Power Rating (W)	Soldering Method	Number of Turns (Effective Rotation Angle)	Total Resistance Value	TCR (ppm/°C)
PV12□100A01	0.5(70°C)	Flow/Soldering Iron	4	10ohm ±10%	±100
PV12□200A01	0.5(70°C)	Flow/Soldering Iron	4	20ohm ±10%	±100
PV12□500A01	0.5(70°C)	Flow/Soldering Iron	4	50ohm ±10%	±100
PV12□101A01	0.5(70°C)	Flow/Soldering Iron	4	100ohm ±10%	±100
PV12□201A01	0.5(70°C)	Flow/Soldering Iron	4	200ohm ±10%	±100
PV12□501A01	0.5(70°C)	Flow/Soldering Iron	4	500ohm ±10%	±100
PV12□102A01	0.5(70°C)	Flow/Soldering Iron	4	1k ohm ±10%	±100
PV12□202A01	0.5(70°C)	Flow/Soldering Iron	4	2k ohm ±10%	±100
PV12□502A01	0.5(70°C)	Flow/Soldering Iron	4	5k ohm ±10%	±100
PV12□103A01	0.5(70°C)	Flow/Soldering Iron	4	10k ohm ±10%	±100

Continued on the following page. ↗

Continued from the preceding page.

Part Number	Power Rating (W)	Soldering Method	Number of Turns (Effective Rotation Angle)	Total Resistance Value	TCR (ppm/°C)
PV12□203A01	0.5(70°C)	Flow/Soldering Iron	4	20k ohm ±10%	±100
PV12□503A01	0.5(70°C)	Flow/Soldering Iron	4	50k ohm ±10%	±100
PV12□104A01	0.5(70°C)	Flow/Soldering Iron	4	100k ohm ±10%	±100
PV12□204A01	0.5(70°C)	Flow/Soldering Iron	4	200k ohm ±10%	±100
PV12□504A01	0.5(70°C)	Flow/Soldering Iron	4	500k ohm ±10%	±100
PV12□105A01	0.5(70°C)	Flow/Soldering Iron	4	1M ohm ±10%	±100
PV12□205A01	0.5(70°C)	Flow/Soldering Iron	4	2M ohm ±10%	±100

Operating Temperature Range: -55 to 125 °C

The blank column is filled with the code of adjustment direction and lead type (H, P, T and S).

The order quantity should be an integral multiple of the "Minimum Quantity".

Construction

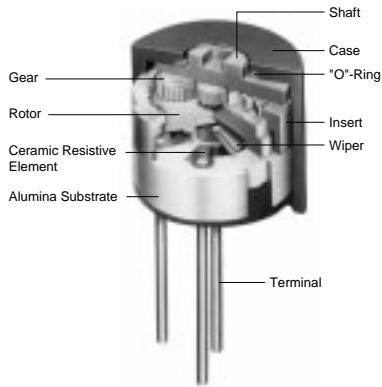

Standard Mounting Holes

PV12H

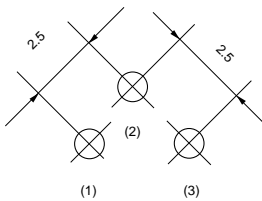

(Tolerance: ±0.1 in mm)

PV12P/PV12S

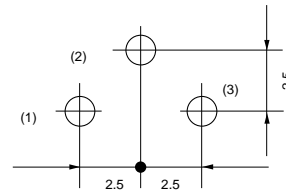

(Tolerance: ±0.1 in mm)

PV12T

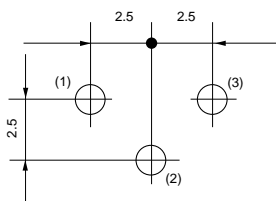

(Tolerance: ±0.1 in mm)

■ Characteristics

Temperature Cycle	ΔTR	$\pm 2\%$
	$\Delta V.S.S.$	$\pm 1\%$
Humidity	ΔTR	$\pm 2\%$
	IR	100M ohm min.
Vibration (20G)	ΔTR	$\pm 1\%$
	$\Delta V.S.S.$	$\pm 1\%$
Shock (100G)	ΔTR	$\pm 1\%$
	$\Delta V.S.S.$	$\pm 1\%$
Temperature Load Life	ΔTR	$\pm 3\%$
	$\Delta V.S.S.$	$\pm 2\%$
Low Temperature Exposure	ΔTR	$\pm 3\%$
	$\Delta V.S.S.$	$\pm 1.5\%$
High Temperature Exposure	ΔTR	$\pm 3\%$
	$\Delta V.S.S.$	$\pm 1.5\%$
Rotational Life (200 cycles)	ΔTR	$\pm 3\%$

ΔTR : Total Resistance Change
 $\Delta V.S.S.$: Voltage Setting Stability
 IR : Insulation Resistance

PV37 Series

■ Features

1. Smaller volume (about one-third) than 25-turns potentiometer
2. Sealed construction protects the interior from dust and liquid, which achieves stable performance.
3. Available for ultrasonic cleaning after soldering
4. Clutch mechanism prevents excessive wiper rotation.
5. 5 standard terminal styles
6. Both top and side adjustment directions
7. To be complied with RoHS directive by new Cd free cermet resistive material. Pb free terminals with Sn plating.

■ Applications

1. Measuring instruments
2. OA equipment
3. Medical equipment
4. Power supply
5. Base station for cellular phone



PV37P

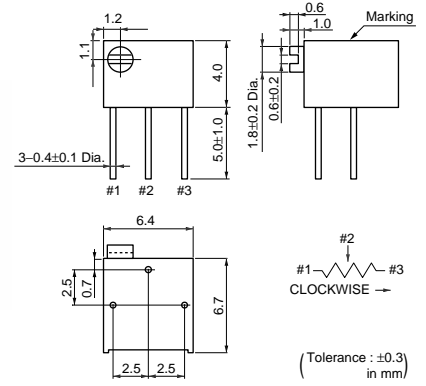

PV37W

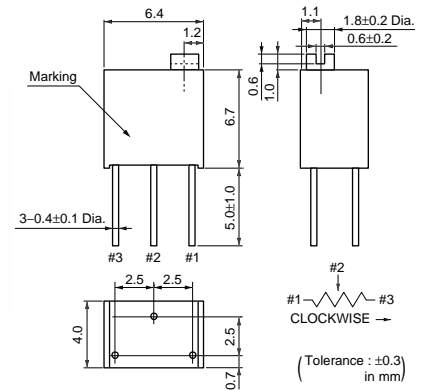

PV37X

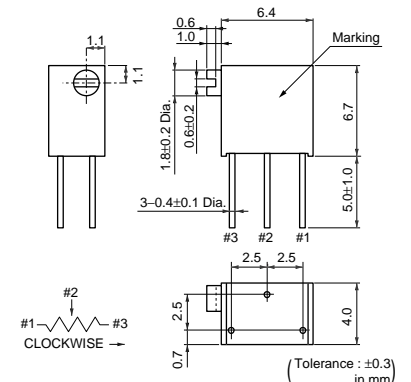

PV37Y

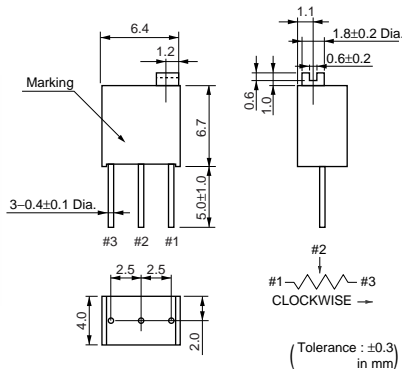

PV37Z

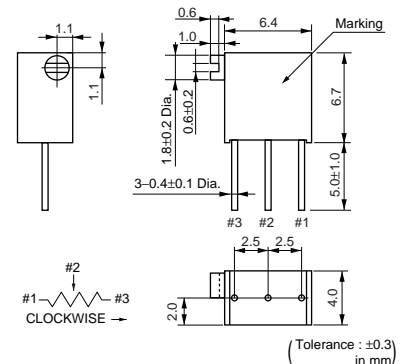

Part Number	Power Rating (W)	Soldering Method	Number of Turns (Effective Rotation Angle)	Total Resistance Value	TCR (ppm/°C)
PV37□100C01	0.25(85°C)	Flow/Soldering Iron	12	10ohm ±10%	±150
PV37□200C01	0.25(85°C)	Flow/Soldering Iron	12	20ohm ±10%	±150
PV37□500C01	0.25(85°C)	Flow/Soldering Iron	12	50ohm ±10%	±150

Continued on the following page.

Continued from the preceding page.

Part Number	Power Rating (W)	Soldering Method	Number of Turns (Effective Rotation Angle)	Total Resistance Value	TCR (ppm/°C)
PV37□101C01	0.25(85°C)	Flow/Soldering Iron	12	100ohm ±10%	±150
PV37□201C01	0.25(85°C)	Flow/Soldering Iron	12	200ohm ±10%	±150
PV37□501C01	0.25(85°C)	Flow/Soldering Iron	12	500ohm ±10%	±150
PV37□102C01	0.25(85°C)	Flow/Soldering Iron	12	1k ohm ±10%	±150
PV37□202C01	0.25(85°C)	Flow/Soldering Iron	12	2k ohm ±10%	±150
PV37□502C01	0.25(85°C)	Flow/Soldering Iron	12	5k ohm ±10%	±150
PV37□103C01	0.25(85°C)	Flow/Soldering Iron	12	10k ohm ±10%	±150
PV37□203C01	0.25(85°C)	Flow/Soldering Iron	12	20k ohm ±10%	±150
PV37□253C01	0.25(85°C)	Flow/Soldering Iron	12	25k ohm ±10%	±150
PV37□503C01	0.25(85°C)	Flow/Soldering Iron	12	50k ohm ±10%	±150
PV37□104C01	0.25(85°C)	Flow/Soldering Iron	12	100k ohm ±10%	±150
PV37□204C01	0.25(85°C)	Flow/Soldering Iron	12	200k ohm ±10%	±150
PV37□254C01	0.25(85°C)	Flow/Soldering Iron	12	250k ohm ±10%	±150
PV37□504C01	0.25(85°C)	Flow/Soldering Iron	12	500k ohm ±10%	±150
PV37□105C01	0.25(85°C)	Flow/Soldering Iron	12	1M ohm ±10%	±150
PV37□205C01	0.25(85°C)	Flow/Soldering Iron	12	2M ohm ±10%	±150
PV37□100C31	0.25(85°C)	Flow/Soldering Iron	12	10ohm ±10%	±150
PV37□200C31	0.25(85°C)	Flow/Soldering Iron	12	20ohm ±10%	±150
PV37□500C31	0.25(85°C)	Flow/Soldering Iron	12	50ohm ±10%	±150
PV37□101C31	0.25(85°C)	Flow/Soldering Iron	12	100ohm ±10%	±150
PV37□201C31	0.25(85°C)	Flow/Soldering Iron	12	200ohm ±10%	±150
PV37□501C31	0.25(85°C)	Flow/Soldering Iron	12	500ohm ±10%	±150
PV37□102C31	0.25(85°C)	Flow/Soldering Iron	12	1k ohm ±10%	±150
PV37□202C31	0.25(85°C)	Flow/Soldering Iron	12	2k ohm ±10%	±150
PV37□502C31	0.25(85°C)	Flow/Soldering Iron	12	5k ohm ±10%	±150
PV37□103C31	0.25(85°C)	Flow/Soldering Iron	12	10k ohm ±10%	±150
PV37□203C31	0.25(85°C)	Flow/Soldering Iron	12	20k ohm ±10%	±150
PV37□253C31	0.25(85°C)	Flow/Soldering Iron	12	25k ohm ±10%	±150
PV37□503C31	0.25(85°C)	Flow/Soldering Iron	12	50k ohm ±10%	±150
PV37□104C31	0.25(85°C)	Flow/Soldering Iron	12	100k ohm ±10%	±150
PV37□204C31	0.25(85°C)	Flow/Soldering Iron	12	200k ohm ±10%	±150
PV37□254C31	0.25(85°C)	Flow/Soldering Iron	12	250k ohm ±10%	±150
PV37□504C31	0.25(85°C)	Flow/Soldering Iron	12	500k ohm ±10%	±150
PV37□105C31	0.25(85°C)	Flow/Soldering Iron	12	1M ohm ±10%	±150
PV37□205C31	0.25(85°C)	Flow/Soldering Iron	12	2M ohm ±10%	±150

Operating Temperature Range: -55 to 125 °C

The blank column is filled with the code of adjustment direction and lead type (P, X, Y, W and Z).

The order quantity should be an integral multiple of the "Minimum Quantity".

The last three digits express the individual specification codes. C01 for standard type and C31 for radial taping type (PV37Y/PV37Z series only).

Construction

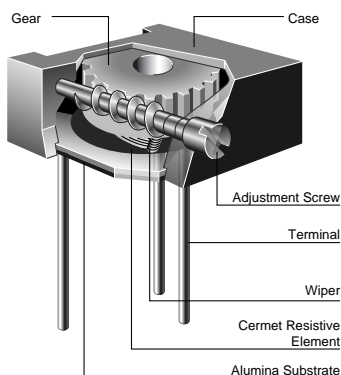

■ Standard Mounting Holes

PV37P

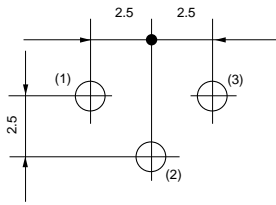

(Tolerance: ±0.1
in mm)

PV37W/PV37X

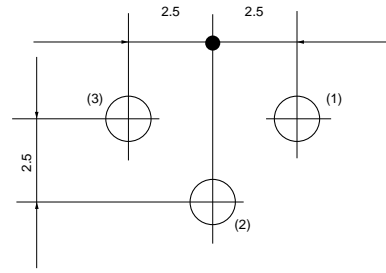

(Tolerance: ±0.1
in mm)

PV37Y/PV37Z

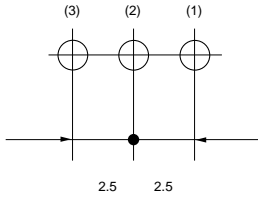

(Tolerance: ±0.1
in mm)

■ Characteristics

Temperature Cycle	ΔTR	±1%
	ΔV.S.S.	±1%
Humidity	ΔTR	±2%
	IR	100M ohm min.
Vibration (20G)	ΔTR	±1%
	ΔV.S.S.	±1%
Shock (100G)	ΔTR	±1%
	ΔV.S.S.	±1%
Temperature Load Life	ΔTR	±2%
	ΔV.S.S.	±1%
Low Temperature Exposure	ΔTR	±1%
	ΔV.S.S.	±1%
High Temperature Exposure	ΔTR	±2%
	ΔV.S.S.	±1%
Rotational Life (200 cycles)	ΔTR	R≤100 ohm ... ±3%
		R>100 ohm ... ±2%

ΔTR : Total Resistance Change
 ΔV.S.S. : Voltage Setting Stability
 IR : Insulation Resistance
 R : Standard Total Resistance

PV23 Series

■ Features

1. Small size (4.6x6.4x19.1mm) and high power rating (0.75W at 70 degree C)
2. Sealed construction protects the interior from dust and liquid, which achieves stable performance.
3. Available for ultrasonic cleaning after soldering
4. Clutch mechanism prevents excessive wiper rotation.
5. To be complied with RoHS directive by new Cd free cermet resistive material. Pb free terminals with Sn plating.

■ Applications

1. Measuring instruments
2. FAX
3. Copier
4. Printers
5. Sensors



PV23P

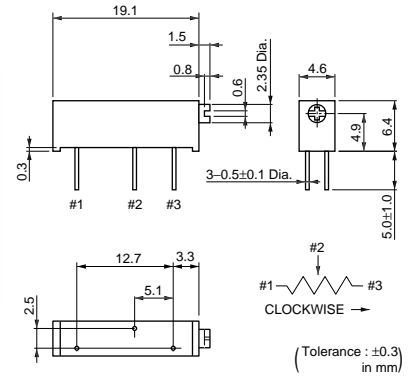

PV23Y

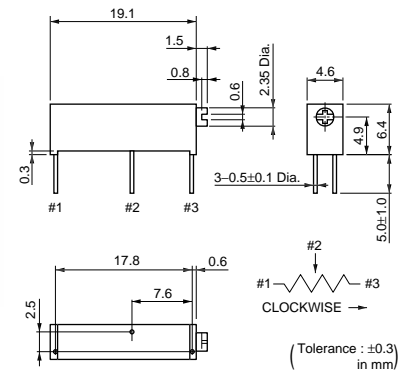

Part Number	Power Rating (W)	Soldering Method	Number of Turns (Effective Rotation Angle)	Total Resistance Value	TCR (ppm/°C)
PV23□100C01	0.75(70°C)	Flow/Soldering Iron	15	10ohm ±10%	±150
PV23□200C01	0.75(70°C)	Flow/Soldering Iron	15	20ohm ±10%	±150
PV23□500C01	0.75(70°C)	Flow/Soldering Iron	15	50ohm ±10%	±150
PV23□101C01	0.75(70°C)	Flow/Soldering Iron	15	100ohm ±10%	±150
PV23□201C01	0.75(70°C)	Flow/Soldering Iron	15	200ohm ±10%	±100
PV23□501C01	0.75(70°C)	Flow/Soldering Iron	15	500ohm ±10%	±100
PV23□102C01	0.75(70°C)	Flow/Soldering Iron	15	1k ohm ±10%	±100
PV23□202C01	0.75(70°C)	Flow/Soldering Iron	15	2k ohm ±10%	±100
PV23□502C01	0.75(70°C)	Flow/Soldering Iron	15	5k ohm ±10%	±100
PV23□103C01	0.75(70°C)	Flow/Soldering Iron	15	10k ohm ±10%	±100
PV23□203C01	0.75(70°C)	Flow/Soldering Iron	15	20k ohm ±10%	±100
PV23□503C01	0.75(70°C)	Flow/Soldering Iron	15	50k ohm ±10%	±100
PV23□104C01	0.75(70°C)	Flow/Soldering Iron	15	100k ohm ±10%	±100
PV23□204C01	0.75(70°C)	Flow/Soldering Iron	15	200k ohm ±10%	±100
PV23□504C01	0.75(70°C)	Flow/Soldering Iron	15	500k ohm ±10%	±100
PV23□105C01	0.75(70°C)	Flow/Soldering Iron	15	1M ohm ±10%	±100
PV23□205C01	0.75(70°C)	Flow/Soldering Iron	15	2M ohm ±10%	±100

Operating Temperature Range: -55 to 125 °C

The blank column is filled with the code of adjustment direction and lead type (P and Y).

The order quantity should be an integral multiple of the "Minimum Quantity".

■ Construction

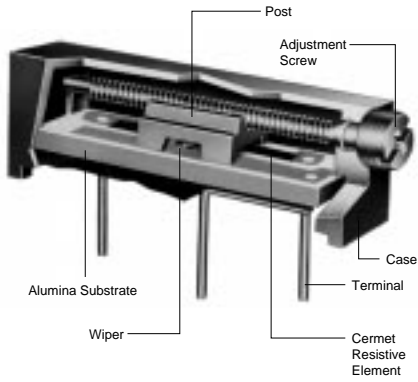

■ Standard Mounting Holes

PV23P

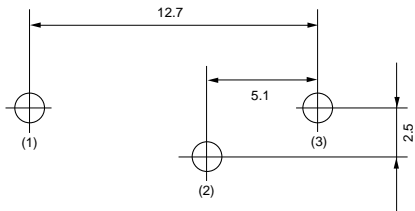

(Tolerance: ±0.1 in mm)

PV23Y

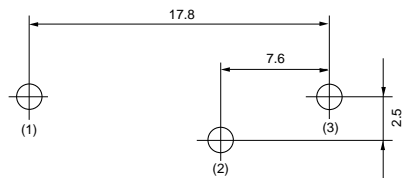

(Tolerance: ±0.1 in mm)

■ Characteristics

Temperature Cycle	ΔTR	±2%
	ΔV.S.S.	±1%
Humidity	ΔTR	±2%
	IR	100M ohm min.
Vibration (20G)	ΔTR	±1%
	ΔV.S.S.	±1%
Shock (50G)	ΔTR	±1%
	ΔV.S.S.	±1%
Temperature Load Life	ΔTR	±3%
	ΔV.S.S.	±1%
Low Temperature Exposure	ΔTR	±1%
	ΔV.S.S.	±1%
High Temperature Exposure	ΔTR	±2%
	ΔV.S.S.	±1%
Rotational Life (200 cycles)	ΔTR	±3%

ΔTR : Total Resistance Change
 ΔV.S.S. : Voltage Setting Stability
 IR : Insulation Resistance

PV22 Series

■ Features

1. High power rating (1W at 70 degree C)
2. Sealed construction protects the interior from dust and liquid, which achieves stable performance.
3. Available for ultrasonic cleaning after soldering
4. Clutch mechanism prevents excessive wiper rotation.
5. To be complied with RoHS directive by new Cd free cermet resistive material. Pb free terminals with Sn plating.

■ Applications

1. Measuring instruments
2. FAX
3. Copier
4. Printers
5. Sensors



PV22L

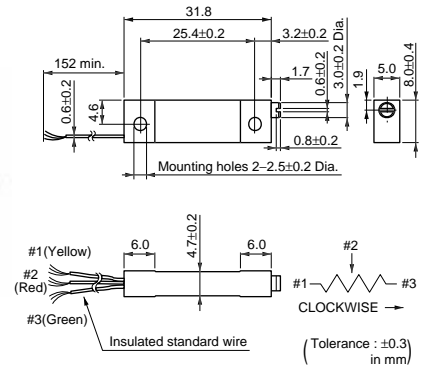

PV22S

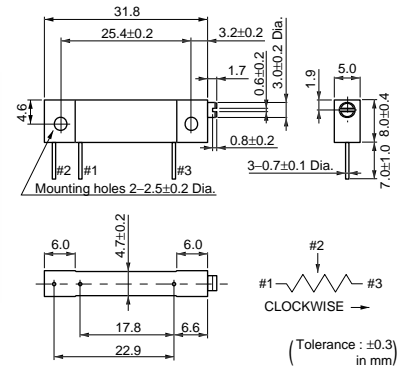

PV22Y

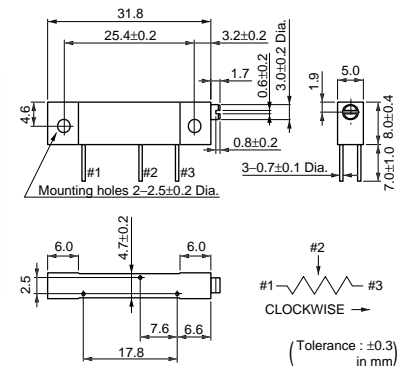

Part Number	Power Rating (W)	Soldering Method	Number of Turns (Effective Rotation Angle)	Total Resistance Value	TCR (ppm/°C)
PV22□100C01	1.0(70°C)	Flow/Soldering Iron	22	10ohm ±10%	±100
PV22□200C01	1.0(70°C)	Flow/Soldering Iron	22	20ohm ±10%	±100
PV22□500C01	1.0(70°C)	Flow/Soldering Iron	22	50ohm ±10%	±100
PV22□101C01	1.0(70°C)	Flow/Soldering Iron	22	100ohm ±10%	±100
PV22□201C01	1.0(70°C)	Flow/Soldering Iron	22	200ohm ±10%	±100
PV22□501C01	1.0(70°C)	Flow/Soldering Iron	22	500ohm ±10%	±100
PV22□102C01	1.0(70°C)	Flow/Soldering Iron	22	1k ohm ±10%	±100
PV22□202C01	1.0(70°C)	Flow/Soldering Iron	22	2k ohm ±10%	±100
PV22□502C01	1.0(70°C)	Flow/Soldering Iron	22	5k ohm ±10%	±100
PV22□103C01	1.0(70°C)	Flow/Soldering Iron	22	10k ohm ±10%	±100
PV22□203C01	1.0(70°C)	Flow/Soldering Iron	22	20k ohm ±10%	±100
PV22□503C01	1.0(70°C)	Flow/Soldering Iron	22	50k ohm ±10%	±100
PV22□104C01	1.0(70°C)	Flow/Soldering Iron	22	100k ohm ±10%	±100
PV22□204C01	1.0(70°C)	Flow/Soldering Iron	22	200k ohm ±10%	±100
PV22□504C01	1.0(70°C)	Flow/Soldering Iron	22	500k ohm ±10%	±100
PV22□105C01	1.0(70°C)	Flow/Soldering Iron	22	1M ohm ±10%	±100

Continued on the following page. ↗

Continued from the preceding page.

Part Number	Power Rating (W)	Soldering Method	Number of Turns (Effective Rotation Angle)	Total Resistance Value	TCR (ppm/°C)
PV22□205C01	1.0(70°C)	Flow/Soldering Iron	22	2M ohm ±10%	±100

Operating Temperature Range: -55 to 150 °C

The blank column is filled with the code of adjustment direction and lead type (L, S and Y).

The order quantity should be an integral multiple of the "Minimum Quantity".

Construction

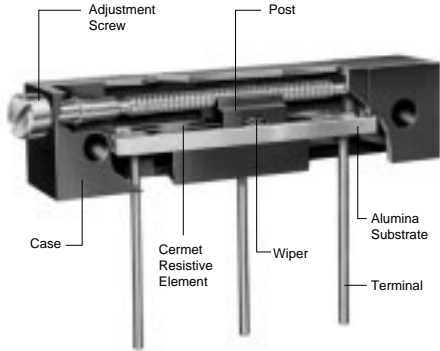

Standard Mounting Holes

PV22S

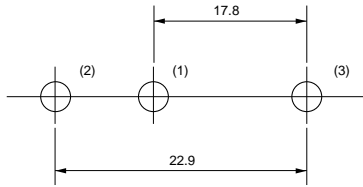

(Tolerance: ±0.1 in mm)

PV22Y

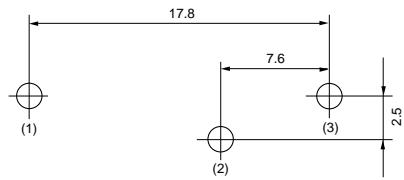

(Tolerance: ±0.1 in mm)

Characteristics

Temperature Cycle	ΔTR	±2%
	ΔV.S.S.	±1%
Humidity	ΔTR	±2%
	IR	100M ohm min.
Vibration (20G)	ΔTR	±1%
	ΔV.S.S.	±1%
Shock (50G)	ΔTR	±1%
	ΔV.S.S.	±1%
Temperature Load Life	ΔTR	±3%
	ΔV.S.S.	±1%
Low Temperature Exposure	ΔTR	±1%
	ΔV.S.S.	±1%
High Temperature Exposure	ΔTR	±2%
	ΔV.S.S.	±1%
Rotational Life (200 cycles)	ΔTR	±2%

ΔTR : Total Resistance Change
 ΔV.S.S. : Voltage Setting Stability
 IR : Insulation Resistance

PV36 Series

■ Features

1. High resolution 25-turns enables precision adjustment easily.
2. Sealed construction protects the interior from dust and liquid, which achieves stable performance.
3. Available for ultrasonic cleaning after soldering
4. Clutch mechanism prevents excessive wiper rotation.
5. 5 standard terminal styles
6. Both top and side adjustment directions.
7. To be complied with RoHS directive by new Cd free cermet resistive material. Pb free terminals with Sn plating.

■ Applications

1. Measuring instruments
2. OA equipment
3. Medical equipment
4. Power supply
5. Base station for cellular phone



PV36P

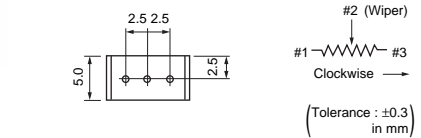
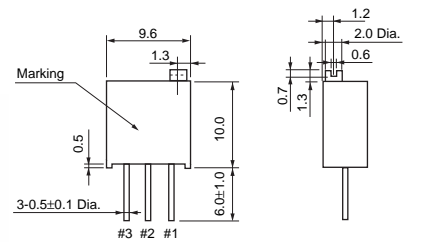
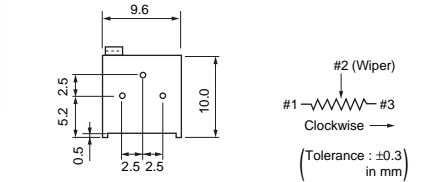
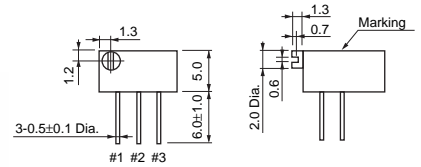

PV36W

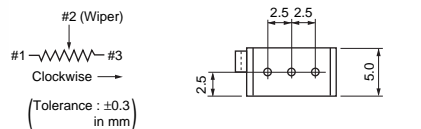
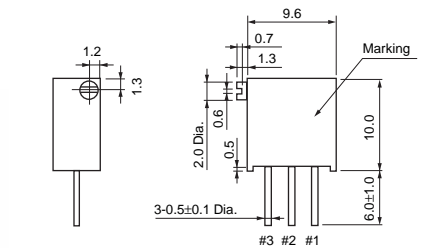

PV36X

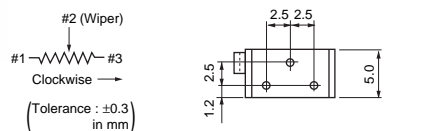
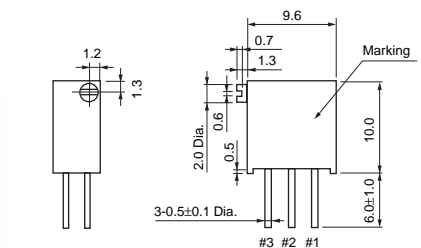

PV36Y

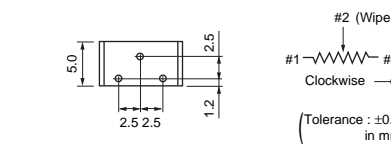
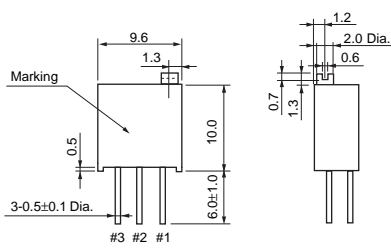

PV36Z

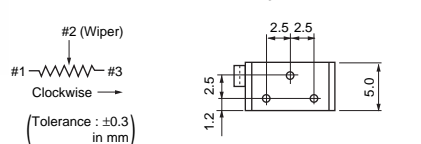
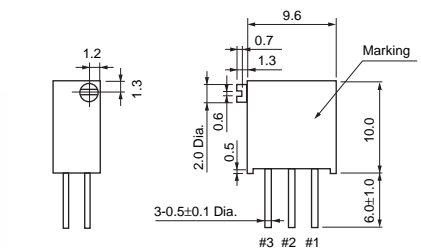

Part Number	Power Rating (W)	Soldering Method	Number of Turns (Effective Rotation Angle)	Total Resistance Value	TCR (ppm/°C)
PV36□100C01	0.5(70°C)	Flow/Soldering Iron	25	10ohm ±10%	±150
PV36□200C01	0.5(70°C)	Flow/Soldering Iron	25	20ohm ±10%	±150
PV36□500C01	0.5(70°C)	Flow/Soldering Iron	25	50ohm ±10%	±150

Continued on the following page.

 Continued from the preceding page.

Part Number	Power Rating (W)	Soldering Method	Number of Turns (Effective Rotation Angle)	Total Resistance Value	TCR (ppm/°C)
PV36□101C01	0.5(70°C)	Flow/Soldering Iron	25	100ohm ±10%	±150
PV36□201C01	0.5(70°C)	Flow/Soldering Iron	25	200ohm ±10%	±100
PV36□501C01	0.5(70°C)	Flow/Soldering Iron	25	500ohm ±10%	±100
PV36□102C01	0.5(70°C)	Flow/Soldering Iron	25	1k ohm ±10%	±100
PV36□202C01	0.5(70°C)	Flow/Soldering Iron	25	2k ohm ±10%	±100
PV36□502C01	0.5(70°C)	Flow/Soldering Iron	25	5k ohm ±10%	±100
PV36□103C01	0.5(70°C)	Flow/Soldering Iron	25	10k ohm ±10%	±100
PV36□203C01	0.5(70°C)	Flow/Soldering Iron	25	20k ohm ±10%	±100
PV36□253C01	0.5(70°C)	Flow/Soldering Iron	25	25k ohm ±10%	±100
PV36□503C01	0.5(70°C)	Flow/Soldering Iron	25	50k ohm ±10%	±100
PV36□104C01	0.5(70°C)	Flow/Soldering Iron	25	100k ohm ±10%	±100
PV36□204C01	0.5(70°C)	Flow/Soldering Iron	25	200k ohm ±10%	±100
PV36□254C01	0.5(70°C)	Flow/Soldering Iron	25	250k ohm ±10%	±100
PV36□504C01	0.5(70°C)	Flow/Soldering Iron	25	500k ohm ±10%	±100
PV36□105C01	0.5(70°C)	Flow/Soldering Iron	25	1M ohm ±10%	±100
PV36□205C01	0.5(70°C)	Flow/Soldering Iron	25	2M ohm ±10%	±100
PV36□100C31	0.5(70°C)	Flow/Soldering Iron	25	10ohm ±10%	±150
PV36□200C31	0.5(70°C)	Flow/Soldering Iron	25	20ohm ±10%	±150
PV36□500C31	0.5(70°C)	Flow/Soldering Iron	25	50ohm ±10%	±150
PV36□101C31	0.5(70°C)	Flow/Soldering Iron	25	100ohm ±10%	±150
PV36□201C31	0.5(70°C)	Flow/Soldering Iron	25	200ohm ±10%	±100
PV36□501C31	0.5(70°C)	Flow/Soldering Iron	25	500ohm ±10%	±100
PV36□102C31	0.5(70°C)	Flow/Soldering Iron	25	1k ohm ±10%	±100
PV36□202C31	0.5(70°C)	Flow/Soldering Iron	25	2k ohm ±10%	±100
PV36□502C31	0.5(70°C)	Flow/Soldering Iron	25	5k ohm ±10%	±100
PV36□103C31	0.5(70°C)	Flow/Soldering Iron	25	10k ohm ±10%	±100
PV36□203C31	0.5(70°C)	Flow/Soldering Iron	25	20k ohm ±10%	±100
PV36□253C31	0.5(70°C)	Flow/Soldering Iron	25	25k ohm ±10%	±100
PV36□503C31	0.5(70°C)	Flow/Soldering Iron	25	50k ohm ±10%	±100
PV36□104C31	0.5(70°C)	Flow/Soldering Iron	25	100k ohm ±10%	±100
PV36□204C31	0.5(70°C)	Flow/Soldering Iron	25	200k ohm ±10%	±100
PV36□254C31	0.5(70°C)	Flow/Soldering Iron	25	250k ohm ±10%	±100
PV36□504C31	0.5(70°C)	Flow/Soldering Iron	25	500k ohm ±10%	±100
PV36□105C31	0.5(70°C)	Flow/Soldering Iron	25	1M ohm ±10%	±100
PV36□205C31	0.5(70°C)	Flow/Soldering Iron	25	2M ohm ±10%	±100

Operating Temperature Range: -55 to 125 °C

The blank column is filled with the code of adjustment direction and lead type (P, X, Y, W and Z).

The order quantity should be an integral multiple of the "Minimum Quantity".

The last three digits express the individual specification codes. C01 for standard type and C31 for radial taping type (PV36W/PV36X series only).

■ Construction

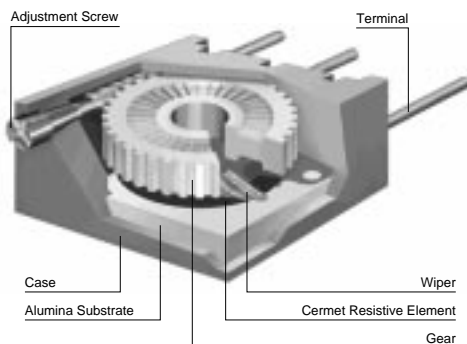

■ Standard Mounting Holes

PV36P

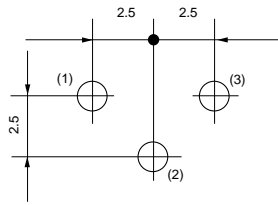

(Tolerance: ±0.1
in mm)

PV36W/X

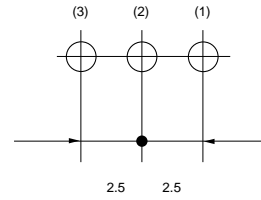

(Tolerance: ±0.1
in mm)

PV36Y/Z

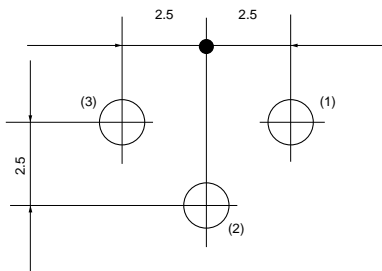

(Tolerance: ±0.1
in mm)

■ Characteristics

Temperature Cycle	ΔTR	±2%
	ΔV.S.S.	±1%
Humidity	ΔTR	±2%
	IR	100M ohm min.
Vibration (20G)	ΔTR	±1%
	ΔV.S.S.	±1%
Shock (100G)	ΔTR	±1%
	ΔV.S.S.	±1%
Temperature Load Life	ΔTR	±3%
	ΔV.S.S.	±1%
Low Temperature Exposure	ΔTR	±2%
	ΔV.S.S.	±1%
High Temperature Exposure	ΔTR	±3%
	ΔV.S.S.	±1%
Rotational Life (200 cycles)	ΔTR	R ≤ 1k ohm, R ≥ 500k ohm ... ±5%
		1k ohm < R < 500k ohm ... ±3%

ΔTR : Total Resistance Change
 ΔV.S.S. : Voltage Setting Stability
 IR : Insulation Resistance
 R : Standard Total Resistance

PV12/PV37/PV23/PV22/PV36 Series Notice

■ Notice (Operating and Storage Conditions)

1. Store in temperatures of -10 to +40 deg. C and relative humidity of 30-85%RH.
2. Do not store in or near corrosive gases.
3. Use within six months after delivery.
4. Open the package just before using.
5. Do not store under direct sunlight.
6. If you use the trimmer potentiometer in an environment other than listed below, please consult with a Murata factory representative prior to using.
The trimmer potentiometer should not be used under the following environmental conditions:

- (1) Corrosive gaseous atmosphere
(Ex. Chlorine gas, Hydrogen sulfide gas, Ammonia gas, Sulfuric acid gas, Nitric oxide gas, etc.)
- (2) In liquid
(Ex. Oil, Medical liquid, Organic solvent, etc.)
- (3) Dusty/dirty atmosphere
- (4) Direct sunlight
- (5) Static voltage nor electric/magnetic fields
- (6) Direct sea breeze
- (7) Other variations of the above

■ Notice (Rating)

1. When using with partial load (rheostat), minimize the power depending on the resistance value.
2. The maximum input voltage to a trimmer potentiometer should not exceed $(P \cdot R)^{1/2}$ or the maximum operating voltage, whichever is smaller.
3. The maximum input current to a trimmer potentiometer should not exceed $(P/R)^{1/2}$ or the allowable wiper current, whichever is smaller.

■ Notice (Soldering and Mounting)

1. Soldering
 - (1) Soldering condition
Refer to the temperature profile.
If the soldering conditions are not suitable, e.g., excessive time and/or excessive temperature, the trimmer potentiometer may deviate from the specified characteristics.
 - (2) To minimize mechanical stress when adjusting, the trimmer potentiometer should be mounted onto PCB without gap.
 - (3) The soldering iron should not come in contact with the case of the trimmer potentiometer. If such contact does occur, the trimmer potentiometer may be damaged.
2. Mounting
 - (1) Use PCB hole to meet the pin of the trimmer potentiometer. If the trimmer potentiometer installs into insufficient PCB hole, the trimmer potentiometer may be damaged by mechanical stress.
 - (2) Do not apply excessive force (preferably 9.8N (Ref.; 1kgf) max.), when the trimmer potentiometer is mounted to the PCB.

3. Cleaning
 - (1) Isopropyl-alcohol and Ethyl-alcohol are applicable solvents for cleaning. If you use any other types of solvents, please consult with a Murata factory representative prior to using.
 - (2) The total cleaning time by cold dipping, vapor and ultrasonic washing (conditions as below) method should be less than 3 minutes.
 - (3) For ultra-sonic cleaning, the available condition is as follows.
 - >Power: 600W (67 liter) max.
 - >Frequency: 28kHz
 - >Temperature: Ambient temperatureDue to the ultra-sonic cleaning equipment's peculiar self-resonance point and that the cleaning compatibility usually depends on the jig construction and/or the cleaning condition such as the depth of immersion, please check the cleaning equipment to determine the suitable conditions.
- If the trimmer potentiometer is cleaned by other conditions, the trimmer potentiometer may be damaged.

PV12/PV37/PV23/PV22/PV36 Series Notice

■ Soldering Profile

● Flow Soldering Profile

Soldering profile for Lead-free solder (96.5Sn/3.0Ag/0.5Cu), Eutectic solder (63Sn/37Pb)

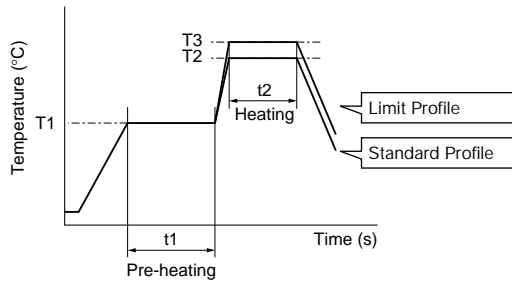

Standard Profile				
Pre-heating		Heating		Cycle of Flow
Temp. (T1)	Time (t1)	Temp. (T2)	Time (t2)	
°C	sec.	°C	sec.	Time
150	60 to 120	250	5 max.	1

Limit Profile				
Pre-heating		Heating		Cycle of Flow
Temp. (T1)	Time (t1)	Temp. (T3)	Time (t2)	
°C	sec.	°C	sec.	Time
150	60 to 120	260	3 max.	1

● Soldering Iron

Standard Condition			
Temperature of Soldering Iron Tip	Soldering Time	Soldering Iron Power Output	Cycle of Soldering Iron
°C	sec.	W	Time
350±10	3 max.	30 max.	1

■ Notice (Handling)

- Use suitable screwdrivers that fit comfortably in driver slot. We recommend the screwdrivers below.
 * Recommended screwdriver for manual adjustment
 ENGINEER INC.: DA-40
 (Murata P/N: KMDR180)
 We can supply the screwdrivers above.
 If you place order, please specify the Murata P/N.
- Don't apply more than 9.8N (Ref.; 1kgf) of twist and stress after mounting onto PCB to prevent contact intermittence. If excessive force is applied, the trimmer potentiometer may not function.
- When adjusting with an adjustment tool, the applied force to the adjustment screw should not exceed 4.9N (Ref.; 500gf). If excessive force is applied, the trimmer potentiometer may not function due to damage.
- When using a lock paint to fix slot position, please use adhesive resin without chlorine or sulfur (Three-bond "1401 series") and evaluate performance by your products. Lock paint may cause corrosion or electrical contact problems.

■ Notice (Other)

- Please make sure that your product has been evaluated and confirmed against your specifications when our product is mounted to your product.
- Murata cannot guarantee trimmer potentiometer integrity when used under conditions other than those specified in this document.

Rotary Position Sensors



SMD/Lead Dust-proof Type 12mm Size SV01 Series

■ Features

1. Dust-proof construction protects the interior from dust, which maintains stable characteristics.
2. Compliant to high peak temperature lead free soldering.
3. Excellent resistance materials and high reliability wiper achieves 1M cycles.
4. D formation thru-hole rotor enables selection of any kind of gear shape.
5. Both D formation thru-hole rotor and T formation thru-hole rotor are available.
6. Leaded terminal type is available.
7. Ultra-thin size (2.1mm height)
8. Au plated terminals without Lead.

■ Applications

1. Animal robot
2. Switch for automotive
3. Motor drive unit
4. Radio control equipment
5. Electric motor-driven bicycle



SV01A

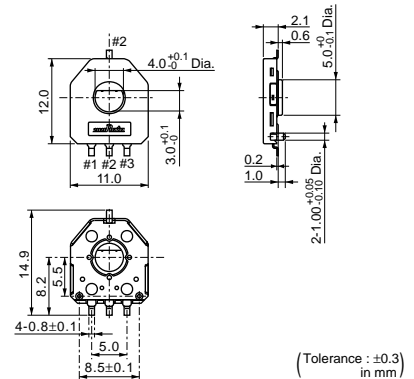

SV01L

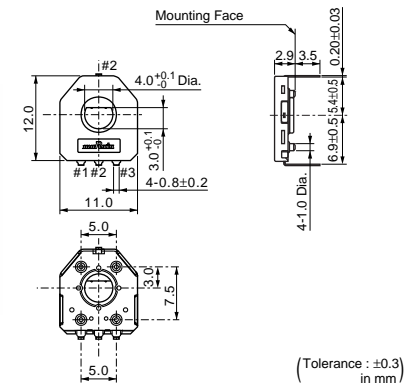

■ T formation Thru-hole rotor

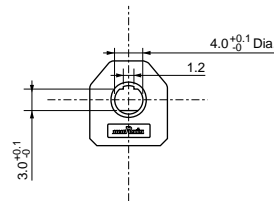

(Tolerance : ±0.3 in mm)

Part Number	Total Resistance Value (k ohm)	Linearity (%)	Effective Rotational Angle	TCR	Rotational Life
SV01A103□EA01	10 ±30%	±2	333.3° (Ref.)	±500ppm/°C	1M cycles
SV01L103□EA11	10 ±30%	±2	333.3° (Ref.)	±500ppm/°C	1M cycles

A blank column is filled with Rotor Formation Codes. (A: D formation thru-hole rotor C: T formation thru-hole rotor)

Construction

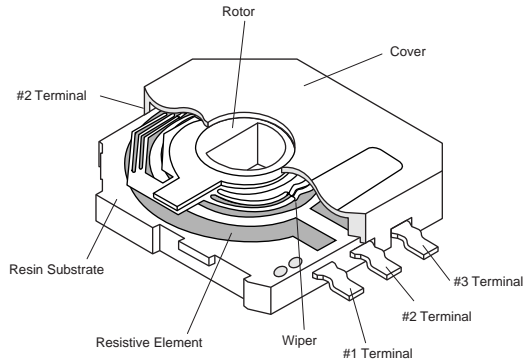

Standard Land Pattern

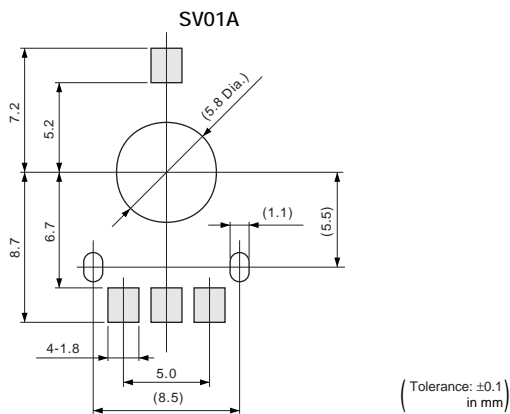

Standard Mounting Holes

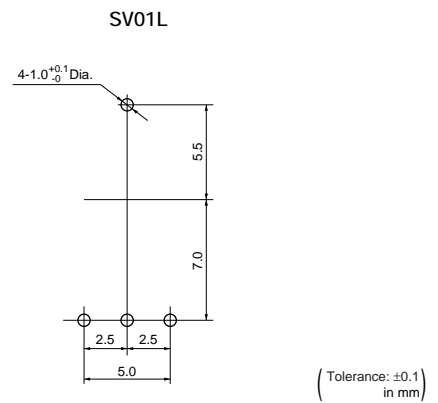

Characteristics

Temperature Cycle (Thermal Shock)	ΔTR	±20%
	Linearity	±3%
Humidity	ΔTR	±20%
	Linearity	±3%
Vibration	ΔTR	±10%
	Linearity	±3%
Shock (20G)	ΔTR	±10%
	Linearity	±3%
Humidity Load Life	ΔTR	±20%
	Linearity	±3%
High Temperature Exposure	ΔTR	+5/-30%
	Linearity	±3%
Low Temperature Exposure	ΔTR	±20%
	Linearity	±3%
Rotational Life (1M cycles)	ΔTR	±20%
	Linearity	±3%

ΔTR: Total Resistance Change

SV01 Series Notice

■ Notice (Operating and Storage Conditions)

1. Store in temperatures of -10 to +40deg. C and relative humidity of 30-85%RH.
2. Do not store in or near corrosive gases.
3. Use within six months after delivery.
4. Open the package just before using.
5. Do not store under direct sunlight.
6. Do not use the rotary position sensor under the following environmental conditions. If you use the rotary position sensor in an environment other than these listed below, please consult with Murata factory representative prior to using.
 - (1) Corrosive gasses atmosphere
(Ex. Chlorine gas, Hydrogen sulfide gas, Ammonia gas, Sulfuric acid gas, Nitric oxide gas, etc.)
 - (2) In liquid
(Ex. Water, Oil, Medical liquid, Organic solvent, etc.)
 - (3) Dusty / dirty atmosphere
 - (4) Direct sunlight
 - (5) Static voltage nor electric/magnetic fields
 - (6) Direct sea breeze
 - (7) Other variations of the above

■ Notice (Soldering and Mounting)

1. Soldering
 - (1) SV01 series can be soldered by reflow soldering method and soldering iron. Do not use flow soldering method (dipping).
 - (2) The dimension of land pattern used should be Murata's standard land pattern at reflow soldering. Excessive land area may cause displacement due to the effect of the surface tension of the solder. Insufficient land area may cause insufficient soldering strength on PCB. (SMD Type)
 - (3) Soldering condition
Refer to the temperature profile.
If the soldering conditions are not suitable, e.g., excessive time and/or excessive temperature, the rotary position sensor may deviate from the specified characteristics.
 - (4) The amount of solder is critical. Insufficient amounts of solder can lead to insufficient soldering strength on PCB. Excessive amounts of solder may cause bridging between the terminals.
 - (5) The soldering iron should not come in contact with the cover of the rotary position sensor. If such contact does occur, the rotary position sensor may be damaged.
2. Mounting
 - (1) Use PCB hole to meet the pin of the rotary position sensor. If the rotary position sensor is inserted into insufficient PCB hole, the rotary position sensor may be damaged by mechanical stress. (Lead type)
 - (2) Do not apply excessive force (preferable 9.8N (Ref.; 1kgf) max.), when the rotary position sensor is mounted to the PCB.
 - (3) Do not warp and/or bend PCB to prevent the rotary position sensor from breakage.
3. Cleaning
Cannot be cleaned because of open construction.

SV01 Series Notice

■ Soldering Profile

● Reflow Soldering Profile

1. Soldering profile for Lead-free solder (96.5Sn/3.0Ag/0.5Cu)

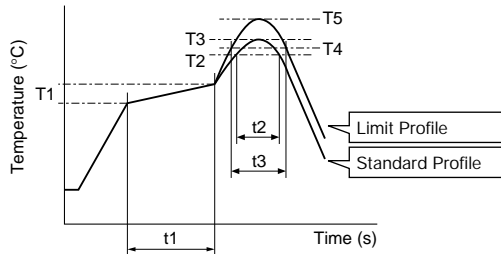

Standard Profile					
Pre-heating		Heating		Peak Temperature (T3)	Cycle of Reflow
Temp. (T1)	Time (t1)	Temp. (T2)	Time (t2)		
°C	sec.	°C	sec.	°C	Time
150 to 180	60 to 120	220	30 to 60	245±3	2

Limit Profile					
Pre-heating		Heating		Peak Temperature (T5)	Cycle of Reflow
Temp. (T1)	Time (t1)	Temp. (T4)	Time (t3)		
°C	sec.	°C	sec.	°C	Time
150 to 180	60 to 120	230	30 to 50	260 +5/-0	2

2. Soldering profile for Eutectic solder (63Sn/37Pb)
(Limit profile: refer to 1)

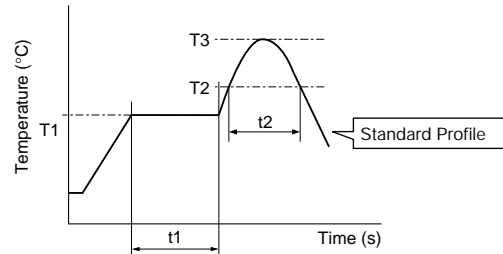

Standard Profile					
Pre-heating		Heating		Peak Temperature (T3)	Cycle of Reflow
Temp. (T1)	Time (t1)	Temp. (T2)	Time (t2)		
°C	sec.	°C	sec.	°C	Time
150	60 to 120	183	30	230	1

● Soldering Iron

Standard Condition			
Temperature of Soldering Iron Tip	Soldering Time	Soldering Iron Power Output	Cycle of Soldering Iron
°C	sec.	W	Time
350±10	3 max.	30 max.	1

■ Notice (Handling)

Uncontrolled mechanical force except usual rotation on the hollow rotor of product, may cause big change of electrical characteristic, big increase of rotational torque or mechanical damage of product.

Therefore, please pay your attention on the following points for your design.

1. The fixing method of product must be soldering by the terminals of product. And please don't fix by screw cramping of supporting board which might cause mechanical deformation of product.
2. Your connecting shaft must be sustained by your bearing and any uncontrolled force should not apply on the hollow rotor of product.

■ Notice (Other)

1. Please make sure the connecting impedance is not to be less than 10M ohm. The rotary position sensor is designed to connect the output terminal and A/D port of the microprocessor directly. Therefore, connecting impedance presupposes certain M ohm and the contact resistance is set high.
2. To minimize the processing error and noise influence which occur in rare cases, when data is installed through the product, please note the following items and program your software.

- (1) Data install should be done plural times and applied the mean value.
- (2) Data considered as error should be invalid.
- (3) If suspicious data is found, the data should be re-installed.
3. Before using rotary position sensor, please test after assembly in your particular mass production system.
4. MURATA cannot guarantee rotary position sensor integrity when used under conditions other than those specified in this document.

Rotary Position Sensors



Connector Dust-proof Type SV21 Series

■ Features

1. Available for 200 degrees max. of effective rotational angle.
2. A programmable hole IC can be available for optional output voltage curve.
3. Temperature compensate range -20 to +85 degree C
4. 10M cycles rotational life
5. Optimal connector: Connector socket and Bushing mount

■ Applications

1. Valve actuator
2. Measuring Equipment
3. Farm Equipment
4. Construction Equipment
5. Mechatronics



SV21

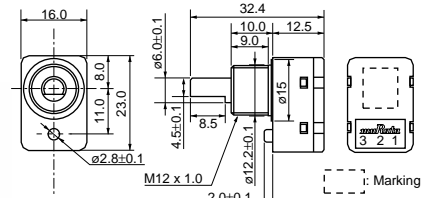

1	Gnd
2	Output
3	+5V DC

(Tolerance : ±0.3 in mm)

The shaft position in this drawing shows 0 deg. angle.
Connector: J.S.T.Mfg Co., Ltd. Model No.: S3B-ZR-SM2

Part Number	Action Voltage	Linearity	Effective Rotational Angle	Rotational Torque	Rotational Life
SV21C201BJA01	5±0.5VDC	±2%FS/±100°	200° max.	5mN·m (Ref.; 50gf·cm) max.	10M cycles

■ Construction

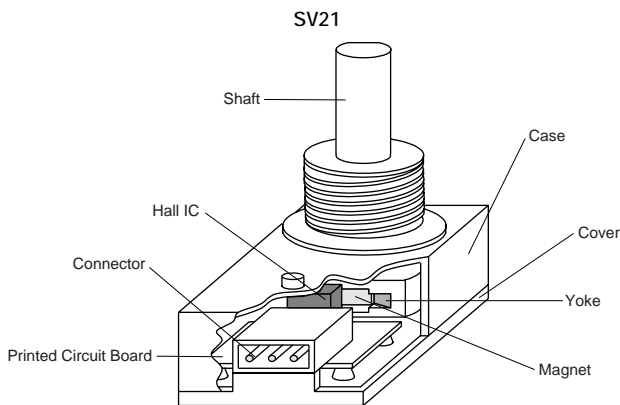

■ Standard Mounting Holes

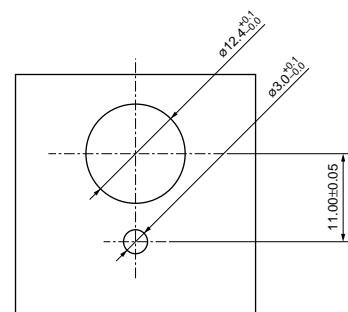

(in mm)

■ Characteristics

Operating Temperature Range	-25 to +85°C
Temperature Characteristics	±4% / 25°C / Full Scale
Input Current	10mA max.
Output Voltage Range	Available to set In range : 10±4% (0.5±0.2V) to 90±4% (4.5±0.2V) of input voltage range
Rotational Life	Linearity: ±3% Full Scale
Vibration	Linearity: ±3% Full Scale
Shock	Linearity: ±3% Full Scale

Optional Output Voltage Curve

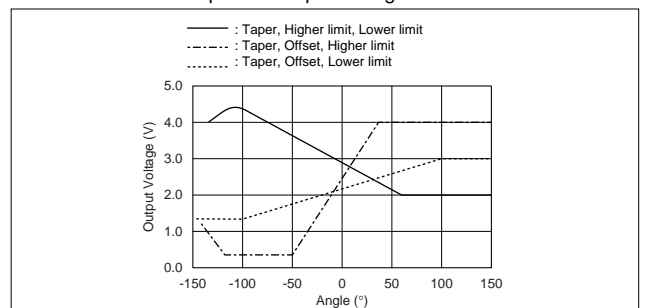

SV21 Series Notice

■ Notice (Operating and Storage Conditions)

1. Store in temperatures of -10 to +40 deg. C and relative humidity of 30-85%RH.
2. Do not store in or near corrosive gases.
3. Use within six months after delivery.
4. Open the package just before using.
5. Do not store under direct sunlight.
6. Do not use the rotary position sensor under the following environmental conditions. If you use the rotary position sensor in an environment other these listed below, please consult with Murata factory representative prior to using.
 - (1) Corrosive gasses atmosphere
(Ex. Chlorine gas, Hydrogen sulfide gas, Ammonia gas, Sulfuric acid gas, Nitric oxide gas, etc.)
 - (2) In liquid
(Ex. Water, Oil, Medical liquid, Organic solvent, etc.)
 - (3) Dusty / dirty atmosphere
 - (4) Direct sunlight
 - (5) Static voltage nor electric/magnetic fields
 - (6) Direct sea breeze
 - (7) Other variations of the above

■ Notice (Soldering and Mounting)

1. When installing sensor, tighten the nut at the torque levels less than 1.0N.m (10kgf.cm as reference).
The exceeded force might damage the screw thread of sensor.
2. When coupling to the shaft of sensor, handle within max. value of shaft force.
3. Don't wire the sensor while the power supply is ON. Be careful during wiring.
4. Please design the cable wire to avoid the influence of the power line or high voltage line.
5. Please use the recommended connector which is "ZHR-3 series / J.S.T. made".
When using other connector, the contact problem might happen or the connector might be damaged.
6. Can not be cleaned by any solvents due to the open construction.

■ Notice (Handling)

1. Uncontrolled mechanical force except usual rotation on the shaft of product, may cause big change of electrical characteristic, big increase of rotational torque or mechanical damage of product. Therefore, please pay your attention on the following points for your design.
Please design your coupler by holding shaft bush to avoid exceeded radial or thrust shaft force of sensor.
2. The magnetic is installed inside of sensor. Please pay your attention as below.
 - (1) If sensor closes magnetic storage (magnetic tape, floppy disc drive etc.), the magnetic memory might be damaged.
 - (2) Don't close sensor to patient who is wearing electrical medical equipments. The equipment might malfunction due to magnetic influence of sensor.

■ Notice (Other)

1. Input voltage
Please design the input voltage value of less deteriorated with age and smaller ripple because of direct influence for output voltage.
Though the protection circuit of 8.5V is installed, the exceeded input voltage might damage inner circuit of sensor.
2. Influence of magnetic field
Don't place another magnetic materials or magnetic generator. These might happen malfunction of your set due to changing the output voltage of sensor.

SMD Open Type (PVZ2/A2/Z3/S3/A3)/SMD Sealed Type (PVM4A_C01 Series) Specifications and Test Methods

The tests and measurements should be conducted under the condition of 15 to 35°C of temperature, 25 to 75% of relative humidity and 86 to 106 kpa of atmospheric pressure unless otherwise specified. If questionable results occur that have been measured in accordance with the above mentioned conditions, the tests and measurements should be conducted under the condition of 25±2°C of temperature and, 45 to 55% of relative humidity and 86 to 106 kpa of atmospheric pressure.

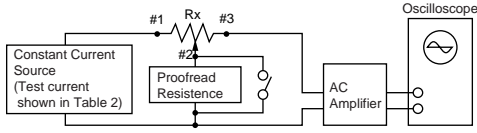
No.	Item	Test Methods																														
1	Total Resistance	<p>Measure total resistance between the resistance element and terminals (terminals #1 and #3) . Use the test voltage specified in Table-1 for total resistance measurements. This voltage should be used whenever a subsequent total resistance measurement is made.</p> <table border="1"> <thead> <tr> <th>Total Resistance, Nominal (ohm)</th> <th>Maximum Test Voltage (V)</th> </tr> </thead> <tbody> <tr> <td>10≤R≤100</td> <td>1.0</td> </tr> <tr> <td>100<R≤1k</td> <td>3.0</td> </tr> <tr> <td>1k<R≤10k</td> <td>10.0</td> </tr> <tr> <td>10k<R≤100k</td> <td>30.0</td> </tr> <tr> <td>100k<R</td> <td>100.0</td> </tr> </tbody> </table> <p>Table 1: Total resistance test voltage</p>	Total Resistance, Nominal (ohm)	Maximum Test Voltage (V)	10≤R≤100	1.0	100<R≤1k	3.0	1k<R≤10k	10.0	10k<R≤100k	30.0	100k<R	100.0																		
Total Resistance, Nominal (ohm)	Maximum Test Voltage (V)																															
10≤R≤100	1.0																															
100<R≤1k	3.0																															
1k<R≤10k	10.0																															
10k<R≤100k	30.0																															
100k<R	100.0																															
2	Residual Resistance	<p>Position the contact arm at the extreme counterclockwise limit of mechanical travel and measure the resistance between the contact arm and the corresponding end terminal. Then, position the contact arm at the extreme clockwise limit of mechanical travel and measure the resistance between the contact arm and the corresponding end terminal. During this test, take suitable precautions to ensure that the rated current of the resistance element is not exceeded.</p>																														
3	Contact Resistance	<p>Contact resistance variation should be measured with the measuring circuit shown below, or its equivalent. The operating wiper should be rotated in both directions through 90% of the actual effective-electrical travel for a total of 6 cycles. The rate of rotation of the operating wiper should be such that the wiper completes 1 count in determining whether or not a contact resistance variation is observed at least twice in the same location. The test current should follow the value given in Table-2 unless otherwise limited by the power rating.</p> <table border="1"> <thead> <tr> <th>Standard Total Resistance R (ohm)</th> <th>Test Current</th> </tr> </thead> <tbody> <tr> <td>100≤R<10k</td> <td>10mA max.</td> </tr> <tr> <td>10k≤R<100k</td> <td>1mA max.</td> </tr> <tr> <td>100k≤R</td> <td>100μA max.</td> </tr> </tbody> </table> <p>Table 2: Test current for CRV</p>  <p>Rx : Trimmer Potentiometer Oscilloscope bandwidth: 100Hz to 50kHz</p> <p>Figure 1: CRV measuring circuit</p>	Standard Total Resistance R (ohm)	Test Current	100≤R<10k	10mA max.	10k≤R<100k	1mA max.	100k≤R	100μA max.																						
Standard Total Resistance R (ohm)	Test Current																															
100≤R<10k	10mA max.																															
10k≤R<100k	1mA max.																															
100k≤R	100μA max.																															
4	Humidity Exposure	<p>The wiper contact point should be preset at about 50% position of effective rotational angle. After that, the potentiometer should be placed in a chamber at 40±2°C and 90 - 95% without loading for 500±12 hours. The resistance value should be measured after keeping the potentiometer in a room for 5±1/6 hours.</p>																														
5	High Temperature Exposure	<p>The wiper contact point should be preset at about 50% position of effective rotational angle. After that, the potentiometer should be placed in a chamber at 70±2°C without loading for 500±12 hours. The resistance value should be measured after keeping the potentiometer in a room for 1.5±1/6 hours.</p>																														
6	Humidity Load Life	<p>The wiper contact point should be preset at about 50% position of effective rotational angle. After that, the potentiometer should be placed in a chamber at 40±2°C and 90 - 95% with loading the 1/2 rated voltage between #1 and #2 terminals, intermittently 1.5 hours ON and 0.5 hours OFF for 1000±12 hours. The resistance value should be measured after keeping the potentiometer in a room for 5±1/6 hours.</p>																														
7	Load Life	<p>The wiper contact point should be preset at about 50% position of effective rotational angle. After that, the potentiometer should be placed in a chamber at 70±2°C (50±2°C for PVZ) with loading the 1/2 rated voltage between #1 and #2 terminals, intermittently 1.5 hours ON and 0.5 hours OFF for 1000±12 hours. The resistance value should be measured after keeping the potentiometer in a room for 1.5±1/6 hours.</p>																														
8	Temperature Cycle	<p>The wiper contact point should be preset at about 50% position of effective rotational angle. After that, the potentiometer should be subjected to Table 3, Table 4 temperature for 5 cycles. The resistance value should be measured after keeping the potentiometer in a room for 1.5±10 minutes.</p> <table border="1"> <thead> <tr> <th>Sequence</th> <th>1</th> <th>2</th> <th>3</th> <th>4</th> </tr> </thead> <tbody> <tr> <td>Temp. (°C)</td> <td>-25±3</td> <td>+25±2</td> <td>+85±3</td> <td>+25±2</td> </tr> <tr> <td>Time (min.)</td> <td>30±3</td> <td>10 max.</td> <td>30±3</td> <td>10 max.</td> </tr> </tbody> </table> <p>Table 3: PVZ</p> <table border="1"> <thead> <tr> <th>Sequence</th> <th>1</th> <th>2</th> <th>3</th> <th>4</th> </tr> </thead> <tbody> <tr> <td>Temp. (°C)</td> <td>-55±3</td> <td>+25±2</td> <td>+125±3</td> <td>+25±2</td> </tr> <tr> <td>Time (min.)</td> <td>30±3</td> <td>10 max.</td> <td>30±3</td> <td>10 max.</td> </tr> </tbody> </table> <p>Table 4: PVA2/PVA3/PVS3/PVM4A□□C01</p>	Sequence	1	2	3	4	Temp. (°C)	-25±3	+25±2	+85±3	+25±2	Time (min.)	30±3	10 max.	30±3	10 max.	Sequence	1	2	3	4	Temp. (°C)	-55±3	+25±2	+125±3	+25±2	Time (min.)	30±3	10 max.	30±3	10 max.
Sequence	1	2	3	4																												
Temp. (°C)	-25±3	+25±2	+85±3	+25±2																												
Time (min.)	30±3	10 max.	30±3	10 max.																												
Sequence	1	2	3	4																												
Temp. (°C)	-55±3	+25±2	+125±3	+25±2																												
Time (min.)	30±3	10 max.	30±3	10 max.																												

Continued on the following page. 

SMD Open Type (PVZ2/A2/Z3/S3/A3)/SMD Sealed Type (PVM4A_C01 Series) Specifications and Test Methods

☐ Continued from the preceding page.

No.	Item	Test Methods																				
9	Temperature Coefficient of Resistance	<p>The trimmer potentiometer should be subjected to each of the following temperatures (see Table 5, Table 6) for 30 to 45 minutes. The resistance value should be measured in the chamber.</p> $TCR = \frac{R_2 - R_1}{R_1 (T_2 - T_1)} \times 10^6 \text{ (ppm/°C)}$ <p style="margin-left: 40px;"> T_1 : Reference temperature in degrees celsius T_2 : Test temperature in degrees celsius R_1 : Resistance at reference temperature in ohm R_2 : Resistance at test temperature in ohm </p> <table style="width: 100%; margin-top: 10px;"> <tr> <td style="border: 1px solid black; padding: 2px;">Sequence</td> <td style="border: 1px solid black; padding: 2px;">1*</td> <td style="border: 1px solid black; padding: 2px;">2</td> <td style="border: 1px solid black; padding: 2px;">3*</td> <td style="border: 1px solid black; padding: 2px;">4</td> </tr> <tr> <td style="border: 1px solid black; padding: 2px;">Temp. (°C)</td> <td style="border: 1px solid black; padding: 2px;">+25±2</td> <td style="border: 1px solid black; padding: 2px;">-25±3</td> <td style="border: 1px solid black; padding: 2px;">+25±2</td> <td style="border: 1px solid black; padding: 2px;">+85±3</td> </tr> </table> <p style="text-align: center; margin-top: 5px;">Table 5: PVZ</p> <table style="width: 100%; margin-top: 10px;"> <tr> <td style="border: 1px solid black; padding: 2px;">Sequence</td> <td style="border: 1px solid black; padding: 2px;">1*</td> <td style="border: 1px solid black; padding: 2px;">2</td> <td style="border: 1px solid black; padding: 2px;">3*</td> <td style="border: 1px solid black; padding: 2px;">4</td> </tr> <tr> <td style="border: 1px solid black; padding: 2px;">Temp. (°C)</td> <td style="border: 1px solid black; padding: 2px;">+25±2</td> <td style="border: 1px solid black; padding: 2px;">-55±3</td> <td style="border: 1px solid black; padding: 2px;">+25±2</td> <td style="border: 1px solid black; padding: 2px;">+125±3</td> </tr> </table> <p style="text-align: center; margin-top: 5px;">Table 6: PVA2/PVA3/PVS3/PVM4A□□□C01</p> <p>Note*: Norm temp.</p>	Sequence	1*	2	3*	4	Temp. (°C)	+25±2	-25±3	+25±2	+85±3	Sequence	1*	2	3*	4	Temp. (°C)	+25±2	-55±3	+25±2	+125±3
Sequence	1*	2	3*	4																		
Temp. (°C)	+25±2	-25±3	+25±2	+85±3																		
Sequence	1*	2	3*	4																		
Temp. (°C)	+25±2	-55±3	+25±2	+125±3																		
10	Rotational Life	<p>The wiper should be rotated over 90% of the effective rotational angle without loading at a speed of 10 cycles per minute, for 10 cycles continuously. The resistance value should be measured after keeping the potentiometer in a room for 10±5 minutes.</p>																				

SMD Sealed Type (PVF2/G3/M4A_D01/G5/01)/Lead Sealed Type (PVC6/32/34/12/37/23/22/36) Specifications and Test Methods

The following describes trimmer potentiometer testing conducted by Murata Manufacturing Co., Ltd. in accordance with MIL-R-22097 (Military specification for variable resistors, non-wirewound) and MIL-STD-202 (Test methods for electronic and electrical component parts).

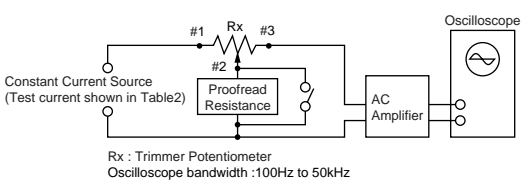
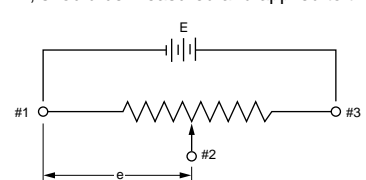
No.	Item	Test Methods																				
1	Total Resistance	<p>Measure total resistance between the resistance element and terminals (#1 and #3) with the contact arm positioned against a stop. The positioning of the contact arm and terminal should be the same for subsequent total resistance measurements on the same device. Use the test voltage specified in Table 1 for total resistance measurements. This voltage should be used for all subsequent total resistance measurements.</p> <table border="1"> <thead> <tr> <th>Total Resistance, Nominal (ohm)</th> <th>Maximum Test Voltage (V)</th> </tr> </thead> <tbody> <tr> <td>10≤R≤100</td> <td>1.0</td> </tr> <tr> <td>100<R≤1k</td> <td>3.0</td> </tr> <tr> <td>1k<R≤10k</td> <td>10.0</td> </tr> <tr> <td>10k<R≤100k</td> <td>30.0</td> </tr> <tr> <td>100k<R</td> <td>100.0</td> </tr> </tbody> </table> <p>Table 1: Total resistance test voltage</p>	Total Resistance, Nominal (ohm)	Maximum Test Voltage (V)	10≤R≤100	1.0	100<R≤1k	3.0	1k<R≤10k	10.0	10k<R≤100k	30.0	100k<R	100.0								
Total Resistance, Nominal (ohm)	Maximum Test Voltage (V)																					
10≤R≤100	1.0																					
100<R≤1k	3.0																					
1k<R≤10k	10.0																					
10k<R≤100k	30.0																					
100k<R	100.0																					
2	Residual Resistance	<p>Position the contact arm at the extreme counterclockwise limit of mechanical travel and measure the resistance between the contact arm and the corresponding end terminal. Then, position the contact arm at the extreme clockwise limit of mechanical travel and measure the resistance between the contact arm and the corresponding end terminal. During this test, take suitable precautions to ensure that the rated current of the resistance element is not exceeded.</p>																				
3	Contact Resistance Variation	<p>Contact resistance variation should be measured with the measuring circuit shown in Figure 1, or its equivalent. The adjustment rotor (screw) should be rotated in both directions through 90% of the actual effective-electrical rotational angle (number of turns) for a total of 6 cycles. Only the last 3 cycles should count in determining whether or not a contact resistance variation is observed at least twice in the same location, exclusive of the roll-on or roll-off points where the contact arm moves from the termination, on or off, the resistance element. The rate of rotation of the adjustment rotor (screw) should be such that the adjustment rotor (screw) completes 1 cycle for 5 seconds minimum to 2 minutes maximum. The test current used should follow the value given in Table 2 unless otherwise limited by power rating.</p> <table border="1"> <thead> <tr> <th>Standard Total Resistance R (ohm)</th> <th>Test Current</th> </tr> </thead> <tbody> <tr> <td>R≤100</td> <td>20mA</td> </tr> <tr> <td>100<R<500</td> <td>10mA</td> </tr> <tr> <td>500≤R<1k</td> <td>4mA</td> </tr> <tr> <td>1k≤R<2k</td> <td>2mA</td> </tr> <tr> <td>2k≤R<50k</td> <td>1mA</td> </tr> <tr> <td>50k≤R<200k</td> <td>200μA</td> </tr> <tr> <td>200k≤R<1M</td> <td>100μA</td> </tr> <tr> <td>1M≤R<2M</td> <td>50μA</td> </tr> <tr> <td>2M≤R</td> <td>30μA</td> </tr> </tbody> </table> <p>Table 2: Test current for CRV</p>  <p>Figure 1: CRV measuring circuit</p>	Standard Total Resistance R (ohm)	Test Current	R≤100	20mA	100<R<500	10mA	500≤R<1k	4mA	1k≤R<2k	2mA	2k≤R<50k	1mA	50k≤R<200k	200μA	200k≤R<1M	100μA	1M≤R<2M	50μA	2M≤R	30μA
Standard Total Resistance R (ohm)	Test Current																					
R≤100	20mA																					
100<R<500	10mA																					
500≤R<1k	4mA																					
1k≤R<2k	2mA																					
2k≤R<50k	1mA																					
50k≤R<200k	200μA																					
200k≤R<1M	100μA																					
1M≤R<2M	50μA																					
2M≤R	30μA																					
4	Temperature Coefficient of Resistance	<p>The trimmer potentiometer should be subjected to each of the following temperatures (see Table 3) for 30-45 minutes. Temperature coefficient of resistance should be applied to the following formula.</p> $TCR = \frac{R_2 - R_1}{R_1 (T_2 - T_1)} \times 10^6 \text{ (ppm/°C)}$ <p>T₁ : Reference temperature in degrees celsius T₂ : Test temperature in degrees celsius R₁ : Resistance at reference temperature ohm R₂ : Resistance at test temperature in ohm</p> <table border="1"> <thead> <tr> <th>Sequence</th> <th>1*</th> <th>2</th> <th>3</th> <th>4*</th> <th>5</th> <th>6</th> </tr> </thead> <tbody> <tr> <td>Temperature (°C)</td> <td>+25</td> <td>-15</td> <td>Min. operating Temperature</td> <td>+25</td> <td>+65</td> <td>Max. operating Temperature</td> </tr> </tbody> </table> <p>Note*: Reference temperature</p> <p>Table 3: Test temperatures</p>	Sequence	1*	2	3	4*	5	6	Temperature (°C)	+25	-15	Min. operating Temperature	+25	+65	Max. operating Temperature						
Sequence	1*	2	3	4*	5	6																
Temperature (°C)	+25	-15	Min. operating Temperature	+25	+65	Max. operating Temperature																
5	Voltage Setting Stability	<p>The wiper should be set at approximately 40% of the actual effective-electrical rotational angle (number of turns). An adequate DC test potential should be applied between terminal #1 and terminal #3. The voltage between terminal #1 and terminal #3, and the voltage between terminal #1 and terminal #2, should be measured and applied to the following formula.</p> $\text{Voltage setting stability} = \left(\frac{e'}{E} - \frac{e}{E} \right) \times 100 \text{ (\%)}$ <p>e : Before test (The voltage between terminal #1 and terminal #2) e' : After test (The voltage between terminal #1 and terminal #2)</p>  <p>Figure 2</p>																				

Continued on the following page. 

SMD Sealed Type (PVF2/G3/M4A_D01/G5/01)/Lead Sealed Type (PVC6/32/34/12/37/23/22/36) Specifications and Test Methods

Continued from the preceding page.

No.	Item	Test Methods																				
6	Temperature Cycle	<p>The trimmer potentiometer should be subjected to Table 4 temperature for 5 cycles. The trimmer potentiometer should be removed from the chamber, and maintained at a temperature of 25±5°C for 1-2 hours.</p> <table border="1"> <thead> <tr> <th>Sequence</th> <th>1</th> <th>2</th> <th>3</th> <th>4</th> </tr> </thead> <tbody> <tr> <td>Temp. (°C)</td> <td>PV□□ series -55±3</td> <td>+25±2</td> <td>+125±3 +150±3</td> <td>+25±2</td> </tr> <tr> <td></td> <td>PV22 series -25±3</td> <td></td> <td>+60±3</td> <td></td> </tr> <tr> <td>Time (min.)</td> <td>30</td> <td>5 max.</td> <td>30</td> <td>5 max.</td> </tr> </tbody> </table> <p>Table 4: One cycle of temperature cycle.</p>	Sequence	1	2	3	4	Temp. (°C)	PV□□ series -55±3	+25±2	+125±3 +150±3	+25±2		PV22 series -25±3		+60±3		Time (min.)	30	5 max.	30	5 max.
Sequence	1	2	3	4																		
Temp. (°C)	PV□□ series -55±3	+25±2	+125±3 +150±3	+25±2																		
	PV22 series -25±3		+60±3																			
Time (min.)	30	5 max.	30	5 max.																		
7	Humidity	<p>1) PVC6, PV12, PV32, PV34 PVM4A□□□D01 series The trimmer potentiometer should be placed in a chamber at a temperature of 40±2°C and a humidity of 90-95% without loading for 250±8 hours (500±12 hours for PVM4A□□□D01 series). The trimmer potentiometer should be removed from the chamber, and maintained at a temperature of 25±5°C for 5±1/6 hours.</p> <p>2) PVF2 series The trimmer potentiometer should be placed in a chamber at 60±2°C and 90-95% without loading for 1000±12 hours. The trimmer potentiometer should be removed from the chamber, and maintained at a temperature of 25±5°C for 5±1/6 hours</p> <p>2) PVG3, PVG5, PV01, PV22, PV23, PV36, PV37 series The trimmer potentiometer should be subjected Figure-3 the programmed humidity environment for 10 cycle. The trimmer potentiometer should be removed from the chamber, and maintained at a temperature of 25±5°C for 1.5±1/2 hours.</p> <p>Figure 3</p>																				
8	Vibration	<p>1) PV□□ series The trimmer potentiometer should be vibrated throughout the frequency range at the 20G level. A complete frequency range, 10Hz to 2000Hz and back, should be made within 15 minutes for a total of 4 sweeps in each of the three axis direction for a total of 12 sweeps.</p> <p>2) PVF2 series The trimmer potentiometer should be subjected to vibration at 0.3 inch amplitude. The frequency should be varied uniformly between the approximate limits of 10Hz and 55Hz. This motion should be applied for period of 2 hours in each of 3 mutually perpendicular directions (total of 6 hours).</p>																				
9	Shock	<p>1) PV□□ series The trimmer potentiometer should be shocked at the 100G (50G for PV22 and PV23 series) level and should be subjected to 4 shocks in each of the three axis directions for a total of 12 shocks.</p> <p>2) PVM4A□□□D01 series The trimmer potentiometer should be shocked at the 100G level and should be subjected to 3 shocks in each of the six axis directions for a total of 18 shocks.</p>																				
10	Temperature Road Life	<p>Full rated continuous working voltage not exceeding the maximum rated voltage should be applied intermittently between terminal #1 and terminal #3 of the trimmer potentiometer, 1.5 hours on and 0.5 hours off, for a total of 1000±12 hours, at a temperature of 70±2°C (85±2°C for PV01 and PV37 series, 50±2°C for PVF2 series). The trimmer potentiometer should be removed from the chamber, and maintained at a temperature of 25±5°C for 1 to 2 hours.</p>																				
11	High Temperature Exposure (Except for PVF2)	<p>The trimmer potentiometer should be placed in a chamber at a temperature of 125±3°C (150±3°C for PV22 series) 250±8 hours without loading. The trimmer potentiometer should be removed from the chamber, and maintained at a temperature of 25±5°C for 1 to 2 hours.</p>																				
12	Low Temperature Exposure (Except for PVF2 and PVM4A□□□D01)	<p>The trimmer potentiometer should be placed in a chamber at a temperature of -55±3°C for 1 hours without loading. Full rated continuous working voltage not exceeding the maximum rated voltage should be applied for 45 minutes. The trimmer potentiometer should be removed from the chamber, and maintained at a temperature of 25±5°C for approximately 24 hours.</p>																				

Continued on the following page. ↗

SMD Sealed Type (PVF2/G3/M4A_D01/G5/01)/Lead Sealed Type (PVC6/32/34/12/37/23/22/36) Specifications and Test Methods

Continued from the preceding page.

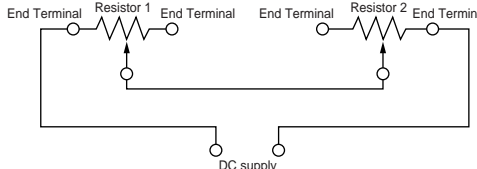
No.	Item	Test Methods
13	Low Temperature Operation (Only for PVF2 and PVM4A□□□D01)	The trimmer potentiometer should be placed in a chamber at a temperature of $-25\pm 3^{\circ}\text{C}$ ($-55\pm 3^{\circ}\text{C}$ for PVM4A□□□D01 series) 48 ± 4 hours without loading. The trimmer potentiometer should be removed from the chamber, and maintained at a temperature of $25\pm 5^{\circ}\text{C}$ for 1-2 hours
14	Rotational Life	<p>1) PV□□ series Full rated continuous working voltage not exceeding the maximum rated voltage should be applied with the circuit shown in the figure. The adjustment rotor (screw) should be continuously cycled through not less than 90% of effective-electrical rotational angle (number of turns), at the rate of 1 cycle for 5 seconds minimum to 2.5 minutes maximum for total of 200 cycles.</p>  <p style="text-align: center;">Figure 4</p> <p>2) PVG3, PVG5 series The adjustment rotor (screw) should be continuously cycled though not less than 90% of effective-electrical rotational angle (number of turns), at the rate of 1 cycle for 5 seconds minimum to 2.5 minutes maximum for a total of 50 (100 for PVG5) cycles, without loading.</p> <p>3) PVF2, PVM4A□□□D01 series The wiper should be rotated over 90% of the effective rotational angle without loading at a speed of 10 cycles per minute, for 100 cycles continuously.</p>

Rotary Position Sensors SMD/Lead Dust-proof Type (SV01) Specifications and Test Methods

The tests and measurements should be conducted under the condition of 15 to 35°C of temperature 25 to 75% of relative humidity and 86 to 106 k Pa of atmospheric pressure unless otherwise specified. In case when entertained a doubt in judgment obtained from results measured in accordance with the above mentioned conditions, the tests and measurements should be conducted under the condition of 25±2°C of temperature and, 50±2% of relative humidity and 86 to 106 k Pa of atmospheric pressure. When the potentiometer is tested after soldering on PCB., it should be tested after being kept in a room (15 to 35°C, 25 to 75%RH) over 24 hours except "Resistance to soldering heat".

No.	Item	Test Methods															
1	Linearity	<p>Independent linearity should vary no more than ±2% within ±160° to 50% voltage ratio. Taper : linear, 100%/333.3° Measured with the circuit as below (Figure 1).</p> <div style="display: flex; justify-content: space-around; align-items: flex-start;"> <div style="text-align: center;"> <p style="font-size: small;">Output voltage ratio (%) $\left(\frac{V(1-2)}{V(1-3)} \times 100 \right)$</p> <p style="font-size: small;">Rotational angle (°)</p> </div> <div style="text-align: center;"> <p style="font-size: small;">DC5V (#3) GND (#1) Connection Impedance : 1M ohm min. Output (#2)</p> </div> </div> <p style="text-align: right; margin-top: 10px;">Figure-1</p>															
2	Temperature Coefficient of Resistance	<p>The rotary position sensor should be subjected to each of the following temperatures (see Table 1) for 30-45 minutes. Temperature coefficient of resistance should be applied to the following formula.</p> $TCR = \frac{R_2 - R_1}{R_1 (t_2 - t_1)} \times 10^6 \text{ (ppm/°C)}$ <p style="font-size: small;"> t_1 : Reference temperature in degrees celsius t_2 : Test temperature in degrees celsius R_1 : Resistance at reference temperature in ohm R_2 : Resistance at test temperature in ohm</p> <table border="1" style="width: 100%; border-collapse: collapse; margin-top: 10px;"> <thead> <tr style="background-color: #e0e0e0;"> <th style="font-size: x-small;">Sequence</th> <th style="font-size: x-small;">*1</th> <th style="font-size: x-small;">2</th> <th style="font-size: x-small;">*3</th> <th style="font-size: x-small;">4</th> </tr> </thead> <tbody> <tr> <td style="font-size: x-small;">Temperature (°C)</td> <td style="font-size: x-small;">+25</td> <td style="font-size: x-small;">-40</td> <td style="font-size: x-small;">+25</td> <td style="font-size: x-small;">+85</td> </tr> </tbody> </table> <p style="font-size: x-small; margin-top: 5px;">Note * : Reference temperature</p> <p style="text-align: center; margin-top: 5px;">Table-1 Test temperatures</p>	Sequence	*1	2	*3	4	Temperature (°C)	+25	-40	+25	+85					
Sequence	*1	2	*3	4													
Temperature (°C)	+25	-40	+25	+85													
3	Temperature Cycle (Thermal Shock)	<p>The rotary position sensor should be subjected to Table 2 temperature for 5 cycles. Then, the rotary position sensor should be kept in the dry box for 24 +8/-0 hrs.</p> <table border="1" style="width: 100%; border-collapse: collapse; margin-top: 10px;"> <thead> <tr style="background-color: #e0e0e0;"> <th style="font-size: x-small;">Sequence</th> <th style="font-size: x-small;">1</th> <th style="font-size: x-small;">2</th> <th style="font-size: x-small;">3</th> <th style="font-size: x-small;">4</th> </tr> </thead> <tbody> <tr> <td style="font-size: x-small;">Temperature (°C)</td> <td style="font-size: x-small;">-40±3</td> <td style="font-size: x-small;">+25±2</td> <td style="font-size: x-small;">+85±3</td> <td style="font-size: x-small;">+25±2</td> </tr> <tr> <td style="font-size: x-small;">Time (min.)</td> <td style="font-size: x-small;">30</td> <td style="font-size: x-small;">5 max.</td> <td style="font-size: x-small;">30</td> <td style="font-size: x-small;">5 max.</td> </tr> </tbody> </table> <p style="text-align: center; margin-top: 5px;">Table 2: One cycle of temperature cycle</p>	Sequence	1	2	3	4	Temperature (°C)	-40±3	+25±2	+85±3	+25±2	Time (min.)	30	5 max.	30	5 max.
Sequence	1	2	3	4													
Temperature (°C)	-40±3	+25±2	+85±3	+25±2													
Time (min.)	30	5 max.	30	5 max.													
4	Humidity	<p>The rotary position sensor should be stored in a chamber at temperature of +60±2°C and relative Humidity of 90-95% for 250±8 hrs. After removing from the chamber, the rotary position sensor should be kept in the dry box for 24 +8/-0 hours.</p>															
5	Vibration	<p>The rotary position sensor should be tested under the condition of the amplitude of 1.5mm, the frequency range from 10 to 55Hz (should be traversed in approximately one minute) and 2 hours in each of 3 mutually perpendicular directions (total 6 hours). Then, the rotary position sensor should be kept in the dry box for 1-2 hrs.</p>															
6	Shock	<p>The rotary position sensor should be tested under the condition of the peak acceleration 20G max. in half-sine wave and 5 shocks in each of 3 mutually perpendicular directions (total 15 shocks). Then, the rotary position sensor should be kept in the dry box for 1-2 hrs.</p>															
7	Humidity Load Life	<p>Full rated continuous working voltage not exceeding 5Vdc should be applied intermittently between terminal #1 and terminal #3 of the rotary position sensor, 1.5 hours on and 0.5 hours off, for 96±4 hours in total in a chamber at a temperature of +40±2°C and relative humidity of 90-95%. After removing from the chamber, the rotary position sensor should be kept in the dry box for 24 +8/-0 hours.</p>															
8	High Temp. Exposure	<p>The rotary position sensor should be stored in a chamber at the temperature of +85±3°C without loading for 250±8 hours. After removing from the chamber, the rotary position sensor should be kept in the dry box for 24 +8/-0 hours.</p>															
9	Low Temp. Exposure	<p>The rotary position sensor should be stored in a chamber at the temperature of -40±3°C without loading for 168±4 hours. After removing from the chamber, the rotary position sensor should be kept in the dry box for 24 +8/-0 hours.</p>															
10	Rotational Life	<p>The adjustment rotor should be continuously rotated within ±160° of effective electrical rotational angle, at the rate of one cycle for 6 seconds for 1 Million cycles under the condition of +25±2°C of temperature without loading.</p>															

Rotary Position Sensors Connector Dust-proof Type (SV21) Specifications and Test Methods

No.	Item	Test Methods
1	Linearity	<p>Linearity is specified the following maximum deviation (C) as percentage of the output voltage (E) from the output voltage approximate straight-line (Y) in FS (full scale) within the electrical effective rotational angle. (Linearity = $C/FS \times 100\%$)</p> <p>Approximate straight-line ($Y=m\theta+b$) is calculated by least square from measured output voltage curve. FS is specified the range from min. output voltage (Y min.) to max. output voltage (Y max.) of approximate straight-line within the electrical effective rotational angle.</p> <div style="text-align: center;"> <p style="font-size: small;">Y = Approximate straight-line of output voltage (V) θ = Rotational angle (°) C = Maximum deviation of output voltage (E1) from output voltage approximate straight-line (Y1)</p> </div>
2	Temperature characteristics	Temperature characteristics is specified as percentage the maximum deviation of output voltage from that at $25\pm 2^\circ\text{C}$ in FS (full scale).
3	Rotational life	The adjustment rotor should be continuously rotated within $\pm 100^\circ$ of effective electrical rotational angle, at the rate of one cycle for 1 seconds for 10 Million cycles under the condition of $25\pm 2^\circ\text{C}$ of temperature without loading.
4	Vibration	The rotary position sensor should be tested under the condition of the amplitude of 1.5mm, the frequency range from 10 to 55Hz (should be traversed in approximately one minute) and 2 hours in each of 3 mutually perpendicular directions (total 6 hours).
5	Shock	The rotary position sensor should be tested under the condition of the peak acceleration 100G max. in half-sine wave and 4 shocks in each of 3 mutually perpendicular directions (total 12 shocks).

Packaging

Minimum Quantity

Part Number	Minimum Quantity (pcs.)					
	ø180mm reel	ø330mm reel	Ammo Pack	Magazine	Bulk	Tray
PVZ2A	3000	12000	—	—	1000	—
PVZ2K/R	3000	—	—	—	1000	—
PVA2	3000	—	—	—	1000	—
PVZ3A	2000	8000	—	—	1000	—
PVZ3K/R	1500	—	—	—	1000	—
PVS3	2500	8000	—	—	1000	—
PVA3	2000	8000	—	—	1000	—
PVG3A/G	1000	—	—	—	500	—
PVG3K	500	—	—	—	—	—
PVM4	500	3000	—	—	500	—
PVF2A	500	—	—	—	100	—
PVG5A	250	—	—	—	50	—
PVG5H	500	—	—	—	50	—
PV01W/P/X	—	—	—	50	—	—
PVC6A/D/G/H/E	—	—	—	50	50	—
PVC6M/Q	—	—	1000	50	50	—
PV34	—	—	—	—	100	—
PV32	—	—	—	—	100	—
PV23/12	—	—	—	—	50	—
PV22	—	—	—	—	30	—
PV36W	—	—	1000	50	50	—
PV36Y	—	—	—	50	50	—
PV36X	—	—	1000	40	50	—
PV36Z/P	—	—	—	40	50	—
PV37Y/Z	—	—	1000	—	50	—
PV37W/X/P	—	—	—	—	50	—
SV01A	—	1000	—	—	50	—
SV01L	—	—	—	—	—	1000
SV21	—	—	—	—	10	—

Dimensions of Reel

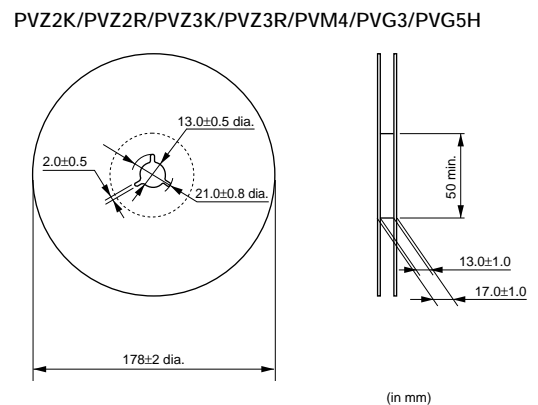
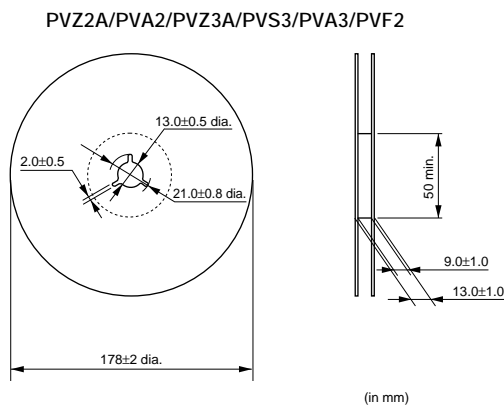

Continued on the following page.

Packaging

Continued from the preceding page.

■ Dimensions of Reel

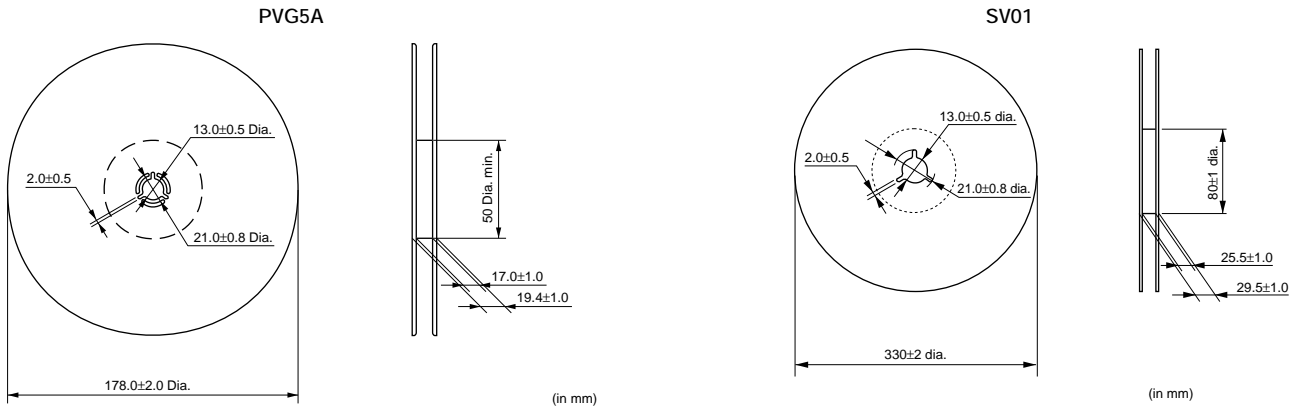

■ Dimensions of Plastic Tape

PVZ2 / PVA2 / PVZ3 / PVA3 / PVS3 / PVF2

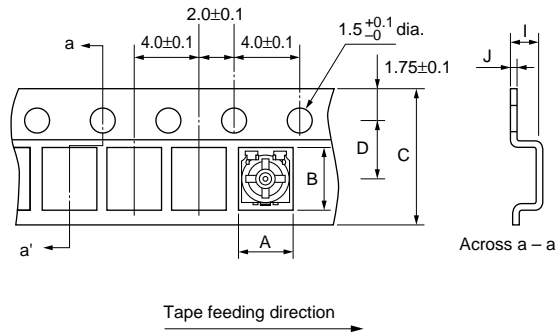

Part Number	A	B	C	D	I	J
PVZ2A	2.4±0.2	3.1±0.1	8.0±0.2	3.5±0.1	1.1±0.1	0.2±0.1
PVZ2K		5.7±0.2	12.0±0.2	5.5±0.1		0.3±0.1
PVZ2R		5.1±0.2			1.0±0.1	
PVA2	3.3±0.2	3.1±0.1	8.0±0.2	3.5±0.1	1.1±0.1	0.2±0.1
PVZ3A/PVA3		3.8±0.2	12.0±0.2	5.5±0.1	1.95±0.1	
PVZ3K		5.8±0.2			2.3±0.1	0.3±0.1
PVZ3R	6.5±0.2	2.1±0.1				
PVS3	2.3±0.2	4.1±0.2	8.0±0.2	3.5±0.1	1.6±0.1	0.2±0.1
PVF2		2.3±0.2	2.3±0.2	3.5±0.1	2.3±0.1	0.3±0.1

• The side containing terminals #1 and #3 faces the plastic tape pilot holes.

(in mm)

Continued on the following page. ↗

Packaging

Continued from the preceding page.

■ Dimensions of Plastic Tape

PVG3A / PVG3G / PVM4 / PVG5H

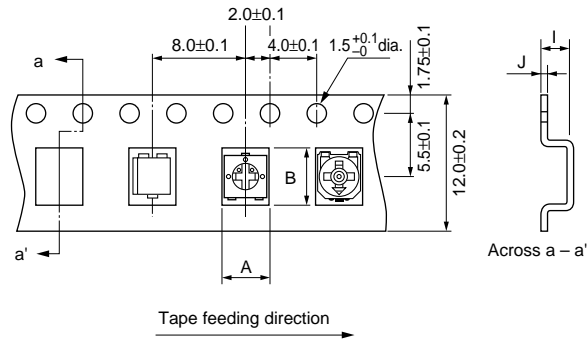

Part Number	A	B	I	J
PVG3A	4.0±0.1	4.0±0.1	2.1±0.1	0.3±0.1
PVG3G		4.9±0.1		
PVM4	4.5±0.2	5.5±0.2	2.15±0.1	0.3±0.1
PVG5H	5.4±0.2	5.8±0.2	4.0±0.1	0.4±0.1

• The side containing terminals #1 and #3 faces the plastic tape pilot holes (except PVG3).

(in mm)

PVG5A

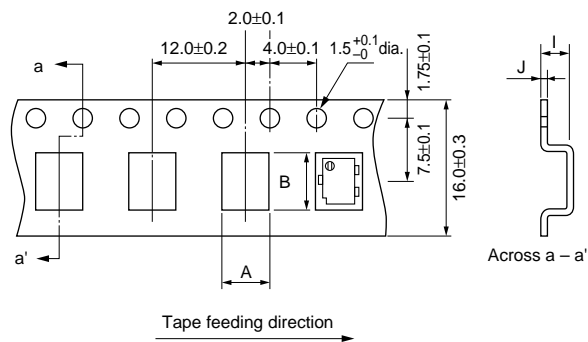

Part Number	A	B	I	J
PVG5A	4.3±0.2	5.4±0.2	5.4±0.1	0.4±0.1

(in mm)

Continued on the following page. ↗

Packaging

Continued from the preceding page.

Dimensions of Plastic Tape

PVG3K

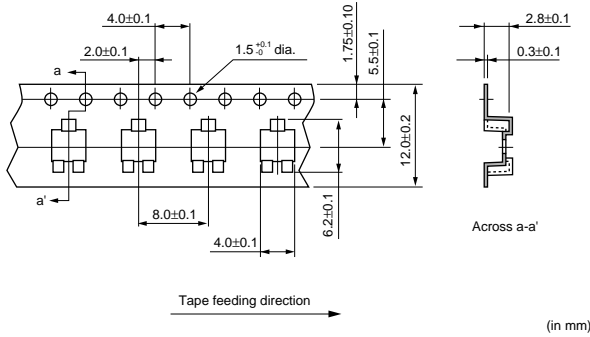

SV01

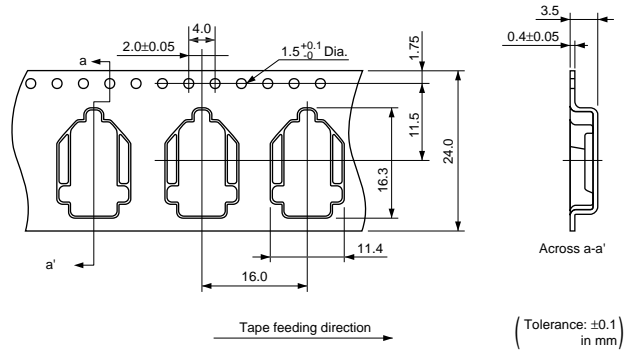

Dimensions of Radial Taping

PVC6M

0.55W×3.2L×1.3D

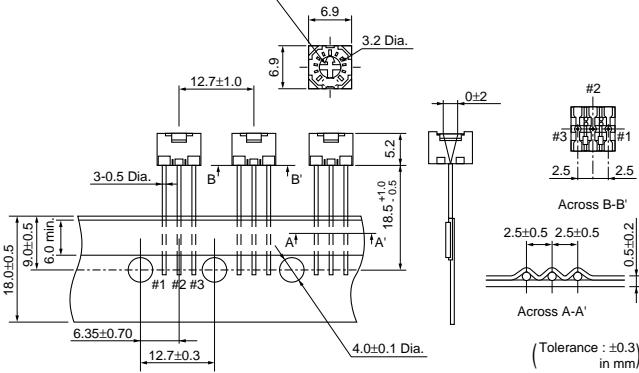

PVC6Q

0.55W×3.2L×1.3D

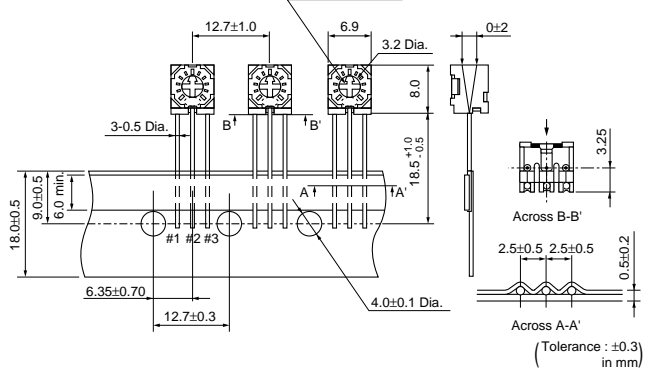

PV37Y

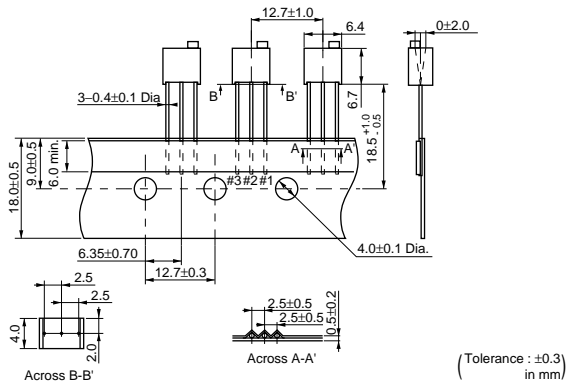

PV37Z

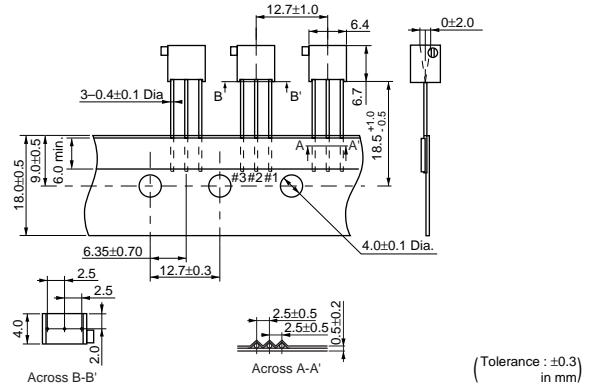

Continued on the following page.

Packaging

Continued from the preceding page.

■ Dimensions of Radial Taping

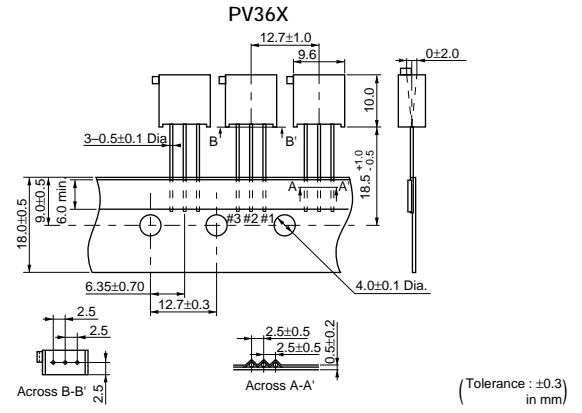
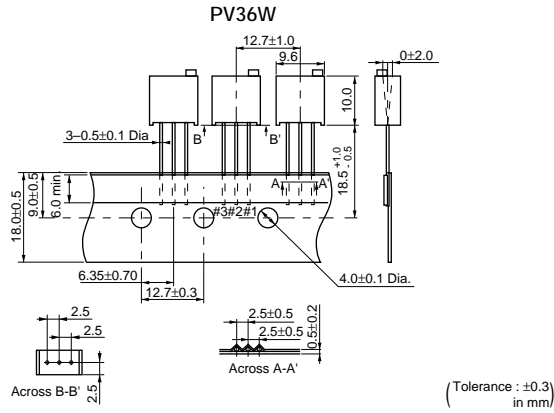

■ Dimensions of Ammo Pack

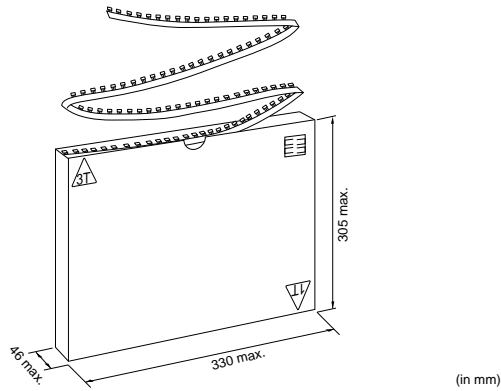

■ Dimensions of Magazine Packaging

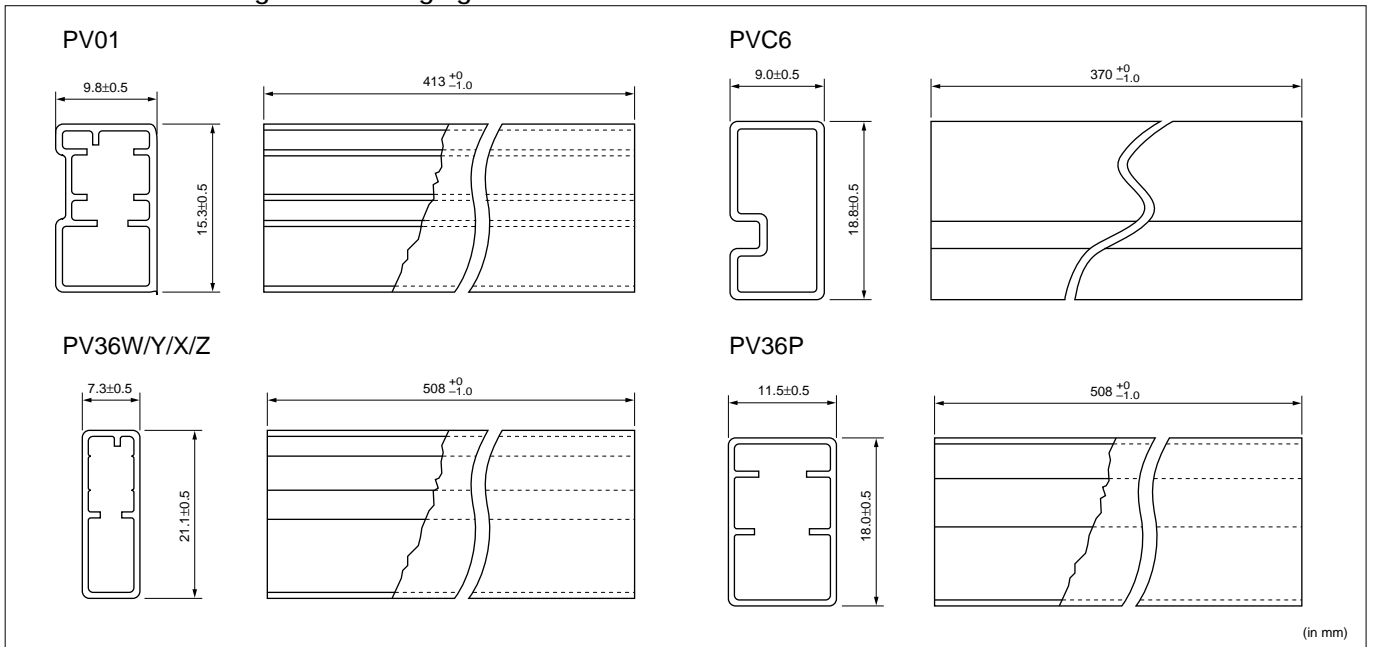

Recommended Adjustment Tools/Qualified Standards

■ Recommended Adjustment Tools

Trimmer Potentiometer Series	Manufacturers	Model Number	MURATA Model Number	Blade
PVZ2/PVA2	MURATA MFG.	KMDR190	KMDR190	+ Cross
PVZ3/PVA3	VESSEL MFG.	No.9000+1.7X30	KMDR080	+ Cross
	TORAY INDUSTRIES, INC.	SA-2225	KMDR070	- Minus (round edge)
PVS3	TORAY INDUSTRIES, INC.	SA-2225	KMDR070	- Minus (round edge)
PVG3	TORAY INDUSTRIES, INC.	SA-2225	KMDR070	- Minus (round edge)
PVM4	VESSEL MFG.	No.9000-2.6X30	KMDR120	- Minus
PVG5	VESSEL MFG.	No.9000-1.3X30	KMDR130	- Minus
	ENGINEER INC.	DA-54		- Minus
PVC6	VESSEL MFG.	No.9000+0X30	KMDR150	+ Cross
	TORAY INDUSTRIES, INC.	SA-2225	KMDR070	- Minus (round edge)
others	VESSEL MFG.	No.9000-1.8X30	KMDR110	- Minus
	ENGINEER INC.	DA-40	KMDR180	- Minus (both ends)
		DA-55		- Minus

■ For Automatic Adjustment

Trimmer Potentiometer Series	Manufacturers	Model Number	MURATA Model Number	Blade
PVZ3 PVA3 PVS3 PVG3	TORAY INDUSTRIES, INC.	JB-2225	KMBT070	- Minus (round edge)
PVC6	VESSEL MFG.	No.CA-10	KMBT090	+ Cross
	TORAY INDUSTRIES, INC.	JB-2225	KMBT070	- Minus (round edge)

■ Qualified Standards

The products listed here have been produced by the ISO9001 and ISO/TS16949 certified factory.

MURATA FACTORY	Qualified Date	Standard	Qualified Number
Sabae Murata Mfg.Co.,Ltd.	August 14, 1997	UNDERWRITERS LABORATORIES INC.	A5704
Wuxi Murata Electronis Co.,Ltd.	May 12, 1999	UNDERWRITERS LABORATORIES INC.	A7924

* No ODCs (Ozone Depleting Chemicals) are used on all Murata's trimmer potentiometers.

△Note:

1. Export Control

〈For customers outside Japan〉

No muRata products should be used or sold, through any channels, for use in the design, development, production, utilization, maintenance or operation of, or otherwise contribution to (1) any weapons (Weapons of Mass Destruction (nuclear, chemical or biological weapons or missiles) or conventional weapons) or (2) goods or systems specially designed or intended for military end-use or utilization by military end-users.

〈For customers in Japan〉

For products which are controlled items subject to the "Foreign Exchange and Foreign Trade Law" of Japan, the export license specified by the law is required for export.

2. Please contact our sales representatives or product engineers before using the products in this catalog for the applications listed below, which require especially high reliability for the prevention of defects which might directly damage a third party's life, body or property, or when one of our products is intended for use in applications other than those specified in this catalog.

- | | |
|-----------------------------|--|
| ① Aircraft equipment | ② Aerospace equipment |
| ③ Undersea equipment | ④ Power plant equipment |
| ⑤ Medical equipment | ⑥ Transportation equipment (vehicles, trains, ships, etc.) |
| ⑦ Traffic signal equipment | ⑧ Disaster prevention / crime prevention equipment |
| ⑨ Data-processing equipment | ⑩ Application of similar complexity and/or reliability requirements to the applications listed above |

3. Product specifications in this catalog are as of May 2005. They are subject to change or our products in it may be discontinued without advance notice. Please check with our sales representatives or product engineers before ordering. If there are any questions, please contact our sales representatives or product engineers.

4. Please read rating and △CAUTION (for storage, operating, rating, soldering, mounting and handling) in this catalog to prevent smoking and/or burning, etc.

5. This catalog has only typical specifications because there is no space for detailed specifications. Therefore, please approve our product specifications or transact the approval sheet for product specifications before ordering.

6. Please note that unless otherwise specified, we shall assume no responsibility whatsoever for any conflict or dispute that may occur in connection with the effect of our and/or a third party's intellectual property rights and other related rights in consideration of your use of our products and/or information described or contained in our catalogs. In this connection, no representation shall be made to the effect that any third parties are authorized to use the rights mentioned above under licenses without our consent.

7. No ozone depleting substances (ODS) under the Montreal Protocol are used in our manufacturing process.