

0331/9353

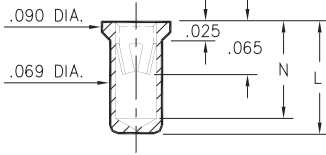

Basic Part Number	Length L	Depth N
0331-0	.150	.127
9353-0	.170	.147

X3XX-X-15-XX-18-XX-10-0

Solder mount in .071 min. mounting hole

7405

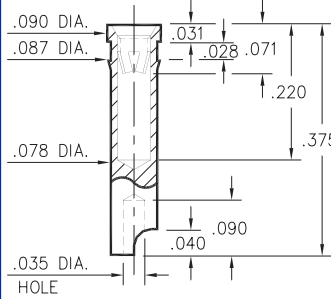

7405-0-18-XX-18-XX-10-0

Press-fit in .084 mounting hole

3450

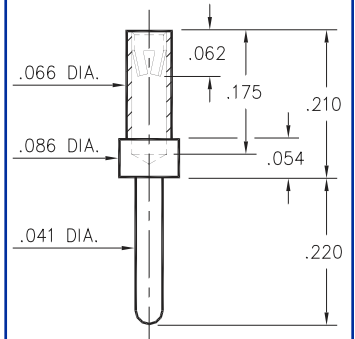

3450-0-15-XX-18-XX-04-0

Solder mount in .043 min. mounting hole

9354/7406

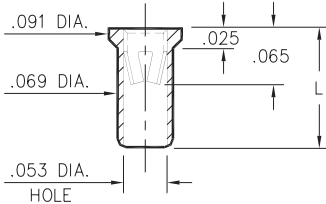

Basic Part Number	Length L
7406-0	.120
9354-0	.170

XXXX-0-15-XX-18-XX-10-0

Solder mount in .071 min. mounting hole

0319

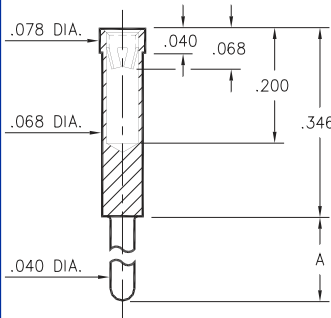

0319-X-15-XX-18-XX-04-0

Solder mount in .042 min. mounting hole

Basic Part Number	Length A
0319-0	.240
0319-1	.280

1313

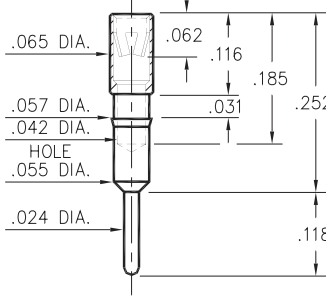

1313-0-15-XX-18-XX-04-0

Press-fit in .056 mounting hole

6628

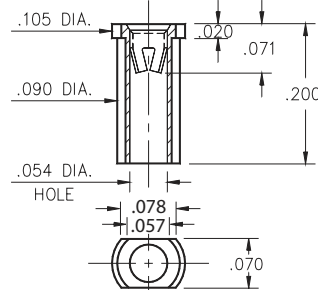

6628-0-18-XX-18-XX-10-0

Surface mount
Also available on 12mm wide carrier tape: 3,700 parts per 13" reel.
Order as: 6628-0-58-XX-18-XX-10-0

3520

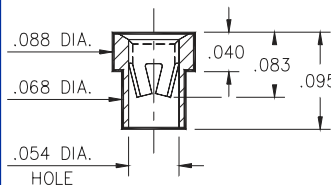

3520-0-15-XX-18-XX-10-0

Solder mount in .070 min. mounting hole

8331

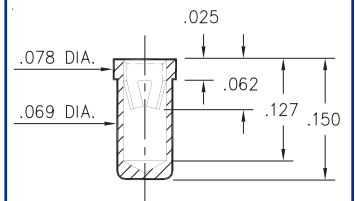

8331-0-15-XX-18-XX-10-0

Solder mount in .071 min. mounting hole

SPECIFICATIONS

SHELL MATERIAL:
Brass Alloy 360, 1/2 Hard

CONTACT MATERIAL:
Beryllium Copper Alloy 172, HT

DIMENSION IN INCHES
TOLERANCES ON:
LENGTHS: ±.005
DIAMETERS: ±.002
ANGLES: ± 2°

ORDER CODE: XXXX - X - 1X - XX - 18 - XX - XX - 0

BASIC PART #

SPECIFY SHELL FINISH:
01 200µ" TIN/LEAD OVER NICKEL
80 200µ" TIN OVER NICKEL ◊
15 10µ" GOLD OVER NICKEL ◊

SPECIFY CONTACT FINISH:
01 200µ" TIN/LEAD OVER NICKEL
80 200µ" TIN OVER NICKEL ◊
27 30µ" GOLD OVER NICKEL ◊



CONTACT

#18 CONTACT (DATA ON PAGE 222)