

- Series 510, 511, 514, 515, 522 & 523 PGA sockets are available on .100" centers.
- Series 513 and 518 PGA sockets are available for Interstitial patterns.
- Choice of three low force clips to cover all applications.
- Hi-Temp PCT polyester insulator material suitable for all forms of soldering.

For RoHS compliance
 select plating code.

For Electrical,
 Mechanical & Environmental
 Data, See pg. 112

XX=Plating Code
 See Below

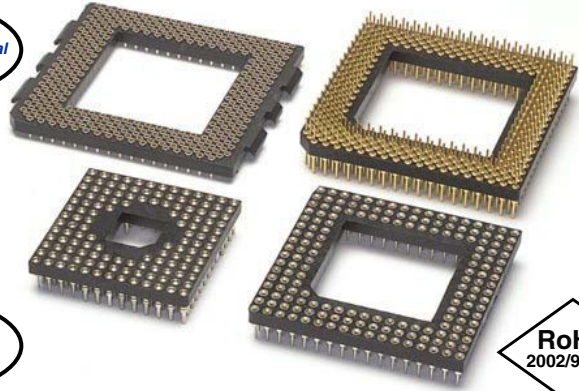

**STANDARD SOLDER TAIL
 SERIES 510**

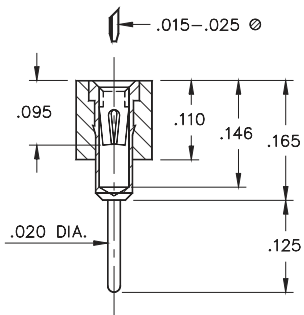

**LONG SOLDER TAIL
 SERIES 511**

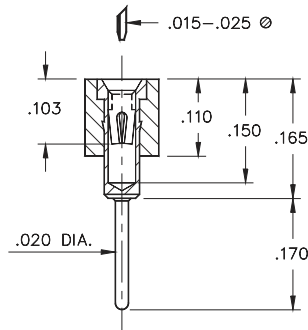

**SMT RECEPTACLE
 SERIES 513**

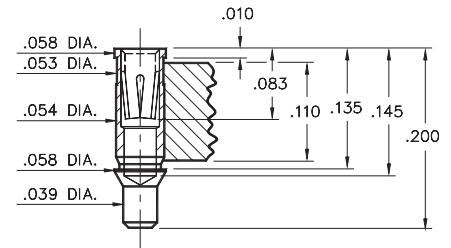

Interstitial Patterns Only

**SMT RECEPTACLE
 SERIES 514**

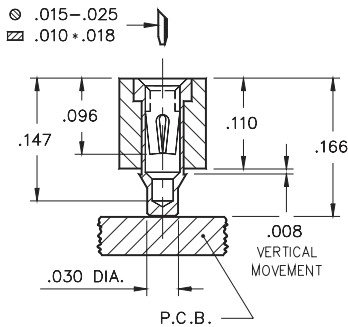

**LOW PROFILE SOLDER TAIL
 SERIES 515**

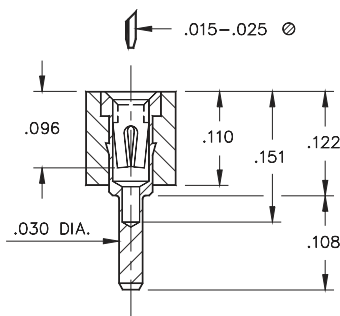

**SOLDER TAIL (Without Heatsink Tabs)
 SERIES 518**

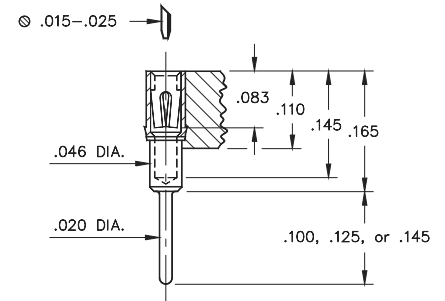

Interstitial Patterns Only

**SOLDER TAIL (With Heatsink Tabs)
 SERIES 518**

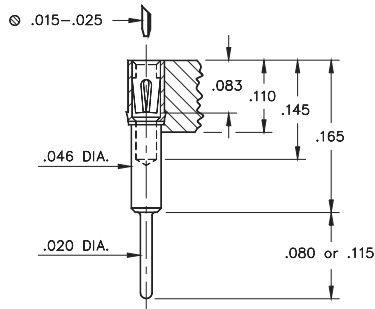

Interstitial Patterns Only

**2 LEVEL WRAPOST
 SERIES 522**

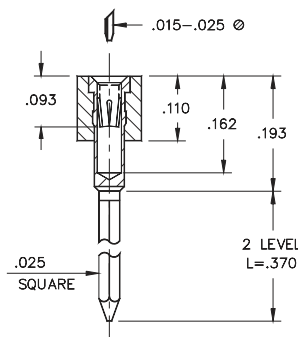

**3 LEVEL WRAPOST
 SERIES 523**

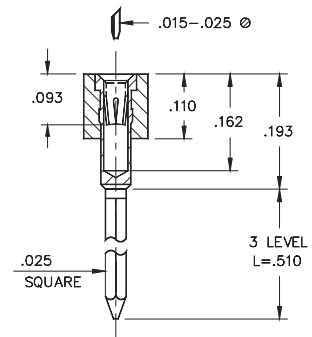

Visit www.mill-max.com/pgs
 To configure a formal Part Number

SPECIFY PLATING CODE XX=	13	93	43
Sleeve (Pin)	10µ" Au	200µ" Sn/Pb	200µ" Sn
Contact (Clip)	30µ" Au	30µ" Au	30µ" Au