



**DS Series
Encoder/Decoder Module
Data Guide**

Wireless made simple[®]

Table of Contents

- 1 [Description](#)
- 1 [Features](#)
- 1 [Applications](#)
- 2 [Ordering Information](#)
- 2 [Absolute Maximum Ratings](#)
- 3 [Electrical Specifications](#)
- 4 [Pin Assignments](#)
- 5 [Pin Descriptions](#)
- 6 [Theory of Operation](#)
- 7 [Initial Operation](#)
- 7 [Encoder Mode](#)
- 7 [Decoder Mode](#)
- 9 [Holtek® Data and Packet Structure](#)
- 11 [Input Type Selection](#)
- 12 [Serial Data and Packet Structure](#)
- 13 [Operation with the Holtek® HT640 and HT658](#)
- 14 [Encoder Typical Application](#)
- 15 [Decoder Typical Application](#)
- 16 [Recommended Pad Layout](#)
- 16 [Production Guidelines](#)
- 17 [Helpful Application Notes from Linx](#)
- 19 [Resources](#)



Warning: Linx products may be used to control machinery or devices remotely, including machinery or devices that can cause death, bodily injuries, and/or property damage if improperly or inadvertently triggered, particularly in industrial settings or other applications implicating life-safety concerns. No Linx Technologies product is intended for use in any application without redundancies where the safety of life or property is at risk.

Configure a unique address. All lines set to ground is the default state for Linx OEM products. Likewise avoid setting all of the address lines to the same state. Failure to configure a unique address could result in unintentional activation from a transmitter that is outside the system.

Do not use any Linx product over the limits in this data guide. Excessive voltage or extended operation at the maximum voltage could cause product failure. Exceeding the reflow temperature profile could cause product failure which is not immediately evident.

Observe appropriate ESD handling procedures. ESD damage could cause product failure which is not immediately evident.

DS Series Encoder/Decoder

Data Guide



Description

The DS Series encoder and decoder is designed for remote control applications. When set as an encoder, the DS encodes 8 data bits and 10 address bits for transmission via RF or infrared. When set as a decoder, the DS compares the address bits in the received packet with its local address. If the bits match, then the received data bits are output on the data lines.

The DS is a replacement for many applications using the Holtek® HT640 and HT658. There are some functional differences that should be reviewed to ensure backwards compatibility.

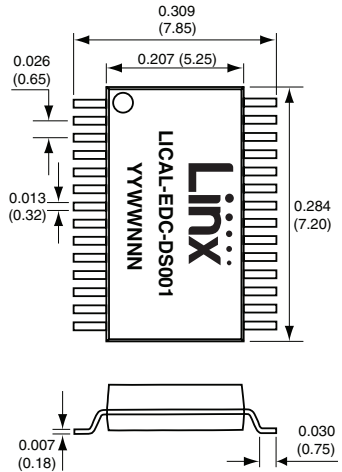

Figure 1: Package Dimensions

Features

- 10 address lines
- 8 data lines
- Low 2.2 to 5.5V operating voltage
- Low supply current (250µA @ 3V encoder, 400µA @ 3V decoder)
- Ultra-low 0.3µA standby current
- No programmer required
- Small SMD package
- Valid transmission indicator

Applications

- Door and Gate Openers
- Remote Device Control
- Car Alarms / Starters
- Home / Industrial Automation
- Remote Status Monitoring
- Lighting Control

Ordering Information

| Ordering Information | |
|----------------------|---------------------------|
| Part Number | Description |
| LICAL-EDC-DS001 | DS Series Encoder/Decoder |
| EVAL-xxx-DS | DS Series Evaluation Kit |

Encoder/Decoders are supplied in tubes of 18 pcs.

Figure 2: Ordering Information

Absolute Maximum Ratings

| Absolute Maximum Ratings | | | | |
|-------------------------------------|------|-----|----------------|-----|
| Supply Voltage V_{CC} | -0.3 | to | +6.5 | VDC |
| Any Input or Output Pin | -0.3 | to | $V_{CC} + 0.3$ | VDC |
| Max. Current Sourced By Output Pins | | 25 | | mA |
| Max. Current Sunk By Output Pins | | 25 | | mA |
| Max. Current Into V_{CC} | | 250 | | mA |
| Max. Current Out Of GND | | 300 | | mA |
| Operating Temperature | -40 | to | +85 | °C |
| Storage Temperature | -65 | to | +150 | °C |

Exceeding any of the limits of this section may lead to permanent damage to the device. Furthermore, extended operation at these maximum ratings may reduce the life of this device.

Figure 3: Absolute Maximum Ratings

Electrical Specifications

| DS Series Encoder/Decoder Specifications | | | | | | |
|--|-------------|----------------|------|----------------|-------------|-------|
| Parameter | Symbol | Min. | Typ. | Max. | Units | Notes |
| Operating Voltage | V_{CC} | 2.2 | | 5.5 | VDC | |
| Encoder Supply Current | I_{CCENC} | | | | | |
| At 2.2V | | | 200 | | μA | 1 |
| At 3.3V | | | 250 | | μA | 1 |
| At 5.0V | | | 400 | | μA | 1 |
| Decoder Supply Current | I_{CCDEC} | | | | | |
| At 2.2V | | | 300 | | μA | 1 |
| At 3.3V | | | 400 | | μA | 1 |
| At 5.0V | | | 675 | | μA | 1 |
| Power-Down Current | I_{PDN} | | | | | |
| At 2.2V | | | 0.3 | | μA | |
| At 3.3V | | | 0.3 | | μA | |
| At 5.0V | | | 0.4 | | μA | |
| Input Low | V_{IL} | 0.0 | | $0.2 * V_{CC}$ | V | 2 |
| Input High | V_{IH} | $0.8 * V_{CC}$ | | V_{CC} | V | 3 |
| Output Low | V_{OL} | 0.0 | | 0.6 | V | |
| Output High | V_{OH} | $V_{CC}-0.7$ | | V_{CC} | V | |
| Input Sink Current | | | | 25 | mA | 4 |
| Output Drive Current | | | | 25 | mA | 4 |
| Operating Temp. Range | | -40 | | +85 | $^{\circ}C$ | |
| Response Time | | | | | | |
| Holtek Protocol | | | 135 | | ms | |
| Serial Protocol | | | 40 | | ms | |

- Current consumption with no active loads.
- For 3V supply, $(0.15 \times 3.0) = 0.45V$ max.
- For 3V supply, $(0.8 \times 3.0) = 2.4V$ min.
- Total current = 300mA

Figure 4: Electrical Specifications



Warning: This product incorporates numerous static-sensitive components. Always wear an ESD wrist strap and observe proper ESD handling procedures when working with this device. Failure to observe this precaution may result in module damage or failure.

Pin Assignments

| | | | |
|----|---------|---------|----|
| 1 | P_SEL | DOUT/VT | 28 |
| 2 | D0 | TE/DIN | 27 |
| 3 | D1 | A9 | 26 |
| 4 | D2 | A8 | 25 |
| 5 | D3 | A7 | 24 |
| 6 | D4 | A6 | 23 |
| 7 | D5 | A5 | 22 |
| 8 | GND | A4 | 21 |
| 9 | D6 | VCC | 20 |
| 10 | D7 | GND | 19 |
| 11 | E/D_SEL | A3 | 18 |
| 12 | D_CFG | A2 | 17 |
| 13 | A_CFG0 | A1 | 16 |
| 14 | A_CFG1 | A0 | 15 |

Figure 5: DS Series Encoder/Decoder Pinout (Top View)

Warning: None of the input lines have internal pull-up or pull-down resistors. The input lines must always be in a known state (either GND or V_{CC}) at all times or the operation may not be predictable. The designer must ensure that the input lines are never floating, either by using external resistors, by tying the lines directly to GND or V_{CC} , or by use of other circuits to control the line state.

Pin Descriptions

| Pin Descriptions | | | |
|--|-------------------|-----|---|
| Pin Number | Name | I/O | Description |
| 1 | P_SEL | I | Protocol Selection. The state of this line determines the data structure and protocol used by the encoder / decoder. Pull low to use the Holtek data structure, pull high to use a serial structure. |
| 2, 3, 4, 5, 6, 7, 9, 10 | D0–D7 | I/O | Data Lines. When in Encoder Mode, the states of these lines are captured when the TE line goes high and encoded for transmission. When in Decoder Mode, these lines will reproduce the state of the encoder's data lines upon reception of a valid packet. |
| 8, 19 | GND | | Ground |
| 11 | E/ \bar{D} _SEL | I | Encoder/Decoder Select. The state of this line determines if the DS is an encoder or a decoder. If the line is high, then the DS enters Encoder Mode. If the line is low, then it enters Decoder Mode. This line is checked once upon power up. |
| 12 | D_CFG | I | Data Line Configuration. Determines whether a low on a data line is interpreted as a zero bit or an open bit. See the Input Type Selection section. |
| 13 | A_CFG0 | I | Address Configuration 0. With A_CFG1, determines the address bit type interpretation. See the Input Type Selection section. |
| 14 | A_CFG1 | I | Address Configuration 1. With A_CFG0, determines the address bit type interpretation. See the Input Type Selection section. |
| 15, 16, 17, 18, 21, 22, 23, 24, 25, 26 | A0–A9 | I | Address Lines. The DS has ten address lines that are used to set a local address. |
| 20 | VCC | | This is the positive power supply. |
| 27 | TE/DIN | I | When in Encoder Mode, this line is the Transmit Enable line. When this line is pulled high, the encoder records the states of the data and address lines, assembles them into a packet, and outputs the packet on the DOUT line three times. When in Decoder Mode, this line is the data input from the receiver. |
| 28 | DOUT/VT | O | When in Encoder Mode, this line is the data output that is connected to the transmitter. When in Decoder Mode, this line is the Valid Transmit indicator and goes high when a valid packet is received. |

Figure 6: DS Series Encoder/Decoder Pin Descriptions

Theory of Operation

The DS Series is a remote control encoder and decoder that offers two protocols in one part based on the state of the P_SEL line. The first protocol operates with the Holtek® HT640 encoder and HT658 decoder. The second is a serial protocol that offers more noise immunity and faster response time while keeping the simple addressing. The DS can operate as either an encoder or decoder based on the state of the E/D_SEL line. It does not operate as both simultaneously.

When set as an encoder it monitors the state of the TE line. When the line is high the DS records the states of the data and address lines, assembles them into a packet and outputs the packet three times. The data lines can be connected to switches or contact closures. The address lines can be set with DIP switches or cut traces on a PCB.

When set as a decoder the DS receives packets and validates them. The validation includes checking the bit timings and comparing the received address to the local address line settings. Two matching packets must be received consecutively. If the timings are good and the addresses match, the DS sets its data lines to match the received states. These lines can be connected to the application circuitry to be controlled.

When the TE/DIN line is low, the DS goes into a low power sleep mode.

Note: The input lines on the DS are not tri-state. They must be pulled high or low and cannot be left floating. This is a key difference between the DS and the Holtek parts.

Initial Operation

On power-up, the E/\overline{D} _SEL line is tested to determine if the DS operates as an encoder or a decoder. If the line is high, the DS enters Encoder Mode. If the line is low, it enters Decoder Mode. This is checked once on power-up. Once the operating mode is selected, the data-line direction is set. In either mode a rising edge on the TE/DIN line wakes the device from low-power sleep.

Encoder Mode

Once the DS enters Encoder Mode, it tests the state of the TE line. If it is high, the P_SEL line is checked to determine which protocol to use. Then the encoder records the states of the Data and Address lines and assembles a packet. When the Holtek® protocol is selected, the DS outputs the packet on the DOUT line three times. With the Serial protocol, the DS sends two packets, checking the states of the data lines each time. The second packet is the logical inversion of the first packet, ensuring a 50% duty cycle and aiding FCC testing. The DS then checks the state of the TE line again. It continues this process for as long as the TE line is high. Once the TE line goes low, the DS goes to sleep until TE is pulled high.

Decoder Mode

When the DS enters Decoder Mode, it checks the state of the DIN line. If the line is high, the P_SEL line is checked to determine which protocol to use. Then the decoder receives the data. It compares the address in the received packet to its local address lines. If the addresses match, then the data is stored and a second packet is received. When the Holtek® protocol is selected, the decoder compares the two packets to each other. If the packets match, then the received data bits are output on the data lines and the VT line is pulled high. The Holtek® protocol compares each packet with the previous one looking for a match. The serial protocol requires two matching packets for initial activation, but then updates the lines on each subsequent packet. The DS then looks for the next packet on the DIN line.

With the Holtek® protocol, once no valid data is received (there is a mismatch of address, of data, or of bit timings), the data and VT lines are pulled low and the DS goes to sleep until DIN is pulled high. The Serial protocol holds the output states until a 130ms timer runs out.

The Holtek® protocol compares two packets and, if they match, sets the outputs. If a data line is toggled during a transmission (for example D1 is activated while D0 is already activated) then the received packet will not

match the previous packet and the output lines will be pulled low until the next packet arrives. This causes all of the outputs to briefly cut out when a line is toggled. The serial protocol uses a timer to prevent this cut out.

Note: The DS rejects packets with addresses set to all high or all low. At least one address line should be different from the rest for correct operation.

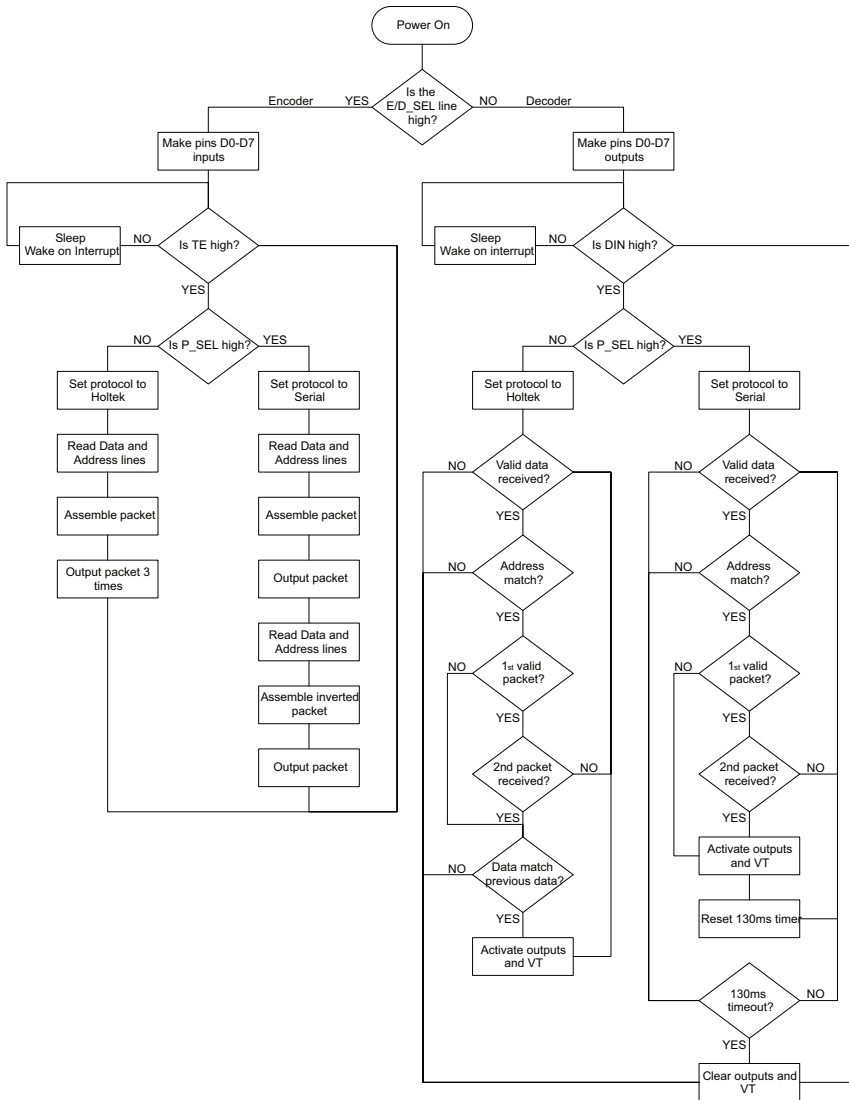

Figure 7: DS Series Encoder/Decoder Flowchart

Holtek Data and Packet Structure

The Holtek® encoders and decoders have tri-state input lines. They recognize three distinct states: one, zero and open. A one bit is set when the line is at V_{CC} . A zero bit is set when the line is at ground. An open bit is set when the line is not connected.

The Holtek® encoders and decoders use a pattern of two logic high pulses and two logic low pulses for each bit. Two of the pulses are double sized and the pattern indicates the type of bit. This is shown in Figure 8.

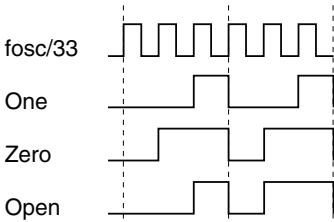

Figure 8: Holtek® Protocol Input Interpretation

Each data packet consists of 6-bit pilot period (logic low), 2-bit SYNC period, and 18-bit code period, as shown in Figure 9.

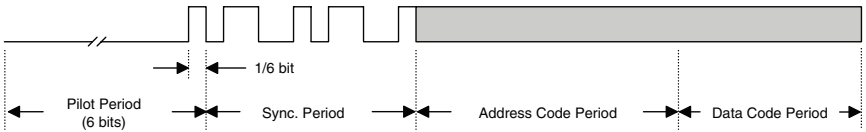

Figure 9: Holtek® Protocol Packet Structure

Example packets are shown in Figure 10 with all lines set in a specific state.

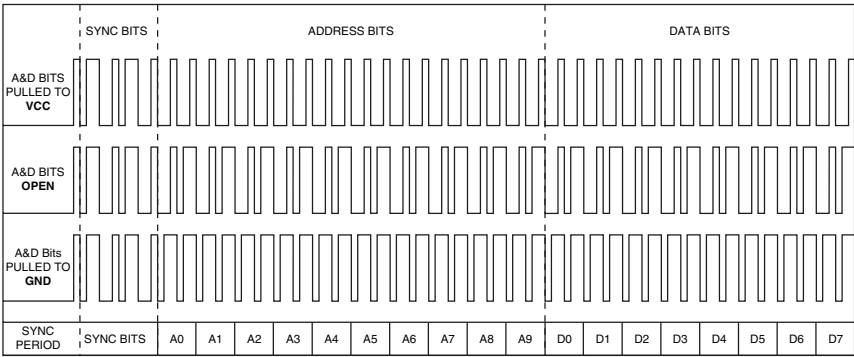

Figure 10: Holtek® Protocol Timing

Figure 11 shows the timings associated with the Holtek® protocol.

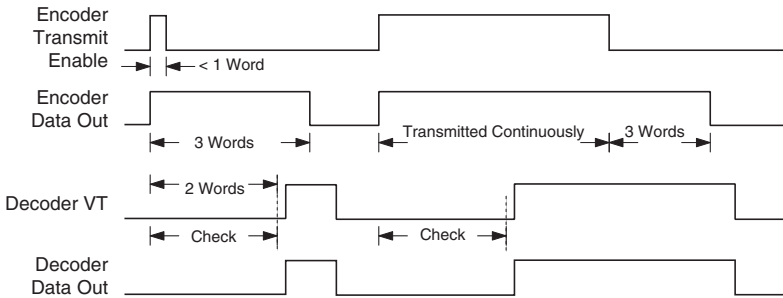

Figure 11: DS Series Timing

Input Type Selection

The Holtek® encoders and decoders have tri-state input lines but the DS has bi-state lines. Tri-state inputs are connected to ground for zero bits, V_{CC} for one bits, or left unconnected for open bits. Since the DS cannot match this operation the D_CFG, A_CFG0 and A_CFG1 lines are provided to select the desired interpretation. The settings must match on both ends.

Pulling D_CFG high configures the data inputs as one and zero. A high on a data line is interpreted as a one bit and a low on the line is interpreted as a zero bit. Pulling D_CFG low configures the data inputs as one and open. A high on a data line is interpreted as a one bit and a low on the line is interpreted as an open bit. The decoder outputs open data bits as logic low. This is shown in Figure 12.

| D_CFG Configuration | | | |
|---------------------|--|--------------------|------|
| Configuration | | Bit Interpretation | |
| D_CFG | | High | Low |
| 0 | | One | Open |
| 1 | | One | Zero |

Figure 12: D_CFG Configuration

A_CFG0 and A_CFG1 are used to select the bit type for the address lines. These are shown in Figure 13.

| A_CFG0 and A_CFG1 Configuration | | | |
|---------------------------------|--------|--------------------|------|
| Configuration | | Bit Interpretation | |
| A_CFG1 | A_CFG0 | High | Low |
| 0 | 0 | One | Zero |
| 0 | 1 | One | Open |
| 1 | 0 | Open | Zero |
| 1 | 1 | One | Zero |

Figure 13: A_CFG0 and A_CFG1 Configuration

Serial Data and Packet Structure

The serial protocol encodes the address and data lines as binary bits that follow logic low and logic high voltage levels. The logic states of each line are recorded and placed into bytes. A checksum is calculated on the bytes and appended to the end of the packet. A preamble and a noise filter are added to the front. The packet is shown in Figure 14.

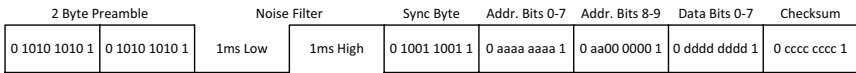

Figure 14: Serial Protocol Packet Structure

The bytes are output in serial fashion at 4,800bps. The DS outputs the packet twice, with the second packet being the logical inversion of the first. This ensures that the duty cycle of the data is always 50%. Adding in the blanking period between packets lowers the duty cycle. This is important for FCC certification where the transmitter output power is a function of the data duty cycle.

This protocol only uses binary states, so the D_CFG, A_CFG0 and A_CFG1 lines are ignored.

The serial protocol is much more immune to bit edge jitter than the Holtek® protocol. This gives much better range and performance within that range. This also gives the DS better immunity to noise from motors, switching power supplies, high current drivers and other noise sources.

This protocol updates the data line states on every packet. This, combined with a faster data rate, give the serial protocol a much faster response time than the Holtek® protocol (36.5ms typical compared to 135ms).

The serial protocol compares two packets as part of the data validation, but also includes a timer that keeps the outputs stable in the case of mismatched packets. This prevents the outputs from turning off at the loss of one packet or when a data line is toggled while another one is active. This helps prevent chattering of relays and other electro-mechanical devices that are not designed for rapid switching. The outputs turn off after 130ms with no valid data.

Operation with the Holtek® HT640 and HT658

The DS is fully compatible with the Holtek® HT640 encoder and the HT658, and HT648L decoders. The primary operational difference is that the DS Series has bi-state address lines (high or low) while the Holtek® parts have tri-state lines (high, low or floating). Since these are distinct states for the Holtek® parts, three configuration lines are used to select how the inputs are interpreted. This accommodates most applications using the Holtek® parts.

Note: Contact Linx for compatibility with other Holtek® encoder/decoder products.

The states of the A_CFG0 and A_CFG1 lines determine how the DS Series interprets the states of its address lines. These lines allow for the use of any two of Holtek's three states at a time. The states are outlined in Figure 13.

The state of the D_CFG line determines how the DS Series interprets the states of its data lines when in Encoder Mode. This allows for the use of any two of Holtek's three states at a time. The states are outlined in Figure 12.

While the DS Series is not fully compatible with the Holtek® parts because of the lack of tri-state lines, the use of the configuration lines allows most applications to make a seamless transition to the DS.

Encoder Typical Application

Figure 15 shows a circuit using the DS Series configured as a Holtek® encoder. This configuration matches the Linx OEM products.

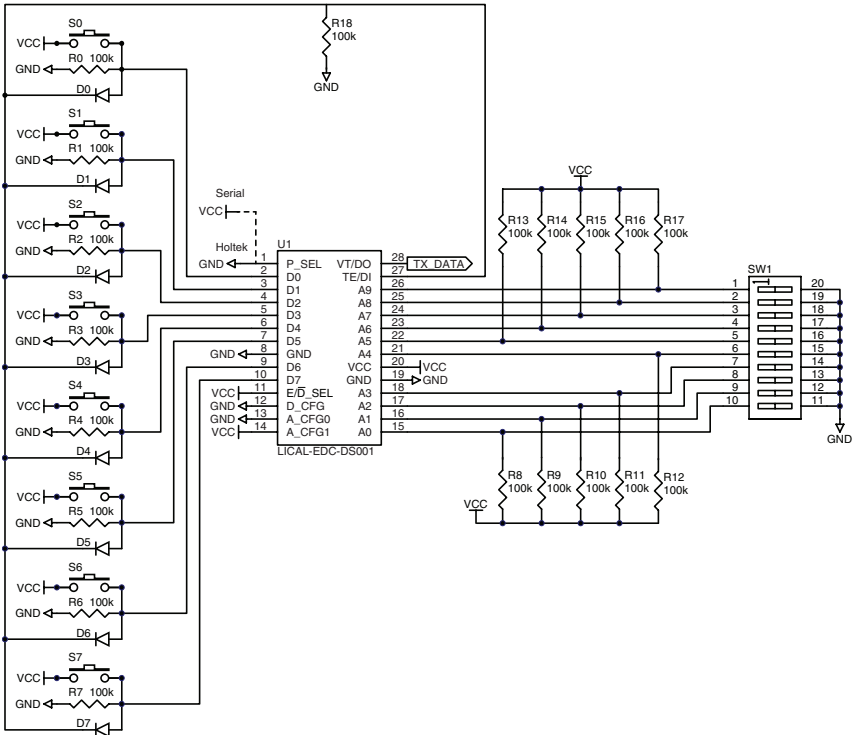

Figure 15: DS Series Typical Application as an Encoder

The P_SEL line is set to Holtek® data (pulling it to Vcc selects the Serial protocol). The E/D_SEL line is pulled high to place the DS into Encoder Mode. The D_CFG is set so that a high on a data line is transmitted as a one bit and a low on the line is transmitted as an open bit. The A_CFG0 and A_CFG1 lines are set to give a high on an address line as an open bit and a low as a zero bit.

The data lines are bi-state, so they have to be high or low. They cannot be floating. Resistors to ground pull the lines low and buttons pull the lines high when pressed. Diodes are used to pull TE high when any button is pressed without activating any other line. This way, pushing any button will cause the encoder to start outputting data.

The address lines are bi-state, so they have to be high or low. They cannot be floating. Resistors pull the lines high and DIP switches pull them low.

Decoder Typical Application

Figure 16 shows a circuit using the DS Series configured as a Holtek® decoder. This configuration matches the Linx OEM products.

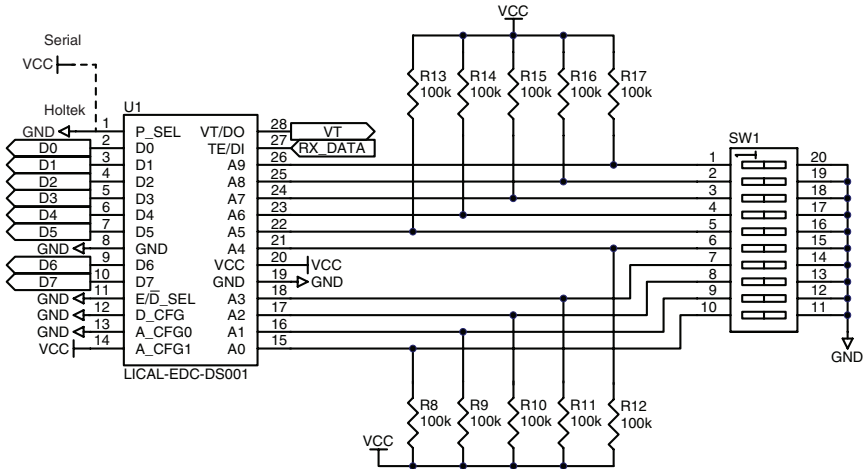

Figure 16: DS Series Typical Application as a Decoder

The P_SEL line is set to Holtek® data. The E/\bar{D} _SEL line is pulled low to place the DS into decoder mode. The A_CFG0 and A_CFG1 lines are set to give a high on an address line as an open bit and a low as a zero bit.

The address lines are bi-state, so they have to be high or low. They cannot be floating. Resistors are used to pull the lines high and DIP switches pull them low when on.

Pulling the P_SEL line to Vcc enables the serial protocol. The rest of the application circuit is the same, though the D_CFG, A_CFG0 and A_CFG1 lines are ignored and can be tied to Vcc or GND with no effect on the operation. They should not be left open.

Recommended Pad Layout

The DS Series encoder/decoder is implemented in a 28-pin Shrink Small Outline Package (28-SSOP). The recommended layout dimensions are in Figure 17.

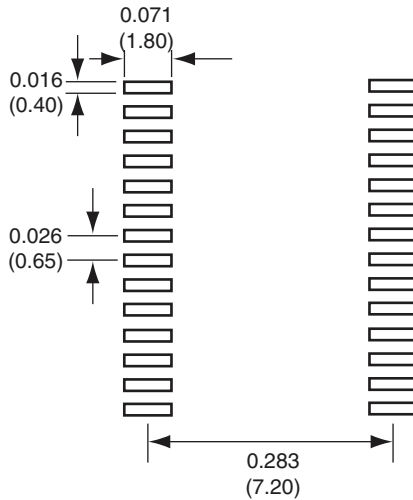

Figure 17: Recommended Footprint

Production Guidelines

These surface-mount components are designed to comply with standard reflow production methods. The recommended reflow profile is shown in Figure 18 and should not be exceeded, as permanent damage to the part may result.

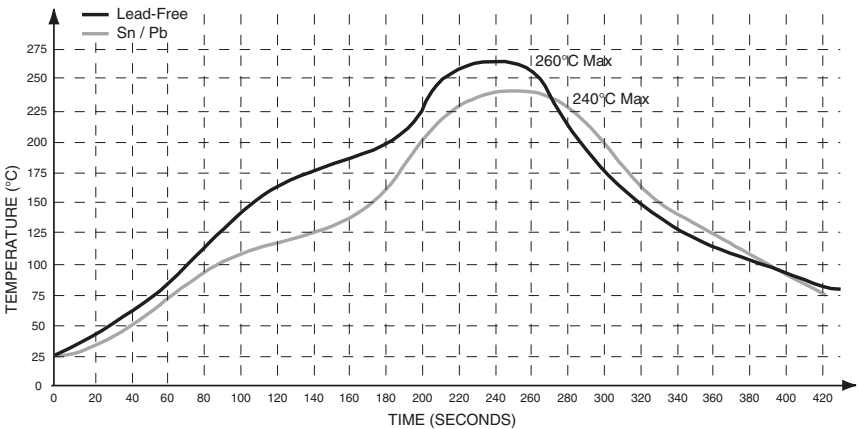

Figure 18: Recommended Solder Profile

Helpful Application Notes from Linx

It is not the intention of this manual to address in depth many of the issues that should be considered to ensure that the modules function correctly and deliver the maximum possible performance. As you proceed with your design, you may wish to obtain one or more of the following application notes which address in depth key areas of RF design and application of Linx products. These application notes are available online at www.linxtechnologies.com or by contacting Linx.

| Helpful Application Note Titles | |
|---------------------------------|---|
| Note Number | Note Title |
| AN-00100 | RF 101: Information for the RF Challenged |
| AN-00300 | Addressing Linx OEM Products |
| AN-00310 | Encoder and Decoder Comparison |

Figure 19: Helpful Application Notes

(This page is intentionally blank.)

Resources

Support

For technical support, product documentation, application notes, regulatory guidelines and software updates, visit www.linstechnologies.com

RF Design Services

For customers who need help implementing Linx modules, Linx offers design services including board layout assistance, programming, certification advice and packaging design. For more complex RF solutions, Apex Wireless, a division of Linx Technologies, creates optimized designs with RF components and firmware selected for the customer's application. Call +1 800 736 6677 (+1 541 471 6256 if outside the United States) for more information.

Antenna Factor Antennas

Linx's Antenna Factor division has the industry's broadest selection of antennas for a wide variety of applications.

For customers with specialized needs, custom antennas and design services are available along with simulations of antenna performance to speed development. Learn more at www.linstechnologies.com.

AntennaFactor
by **Linx**



Linx Technologies
159 Ort Lane
Merlin, OR, US 97532

3090 Sterling Circle Suite 200
Boulder, CO 80301

Phone: +1 541 471 6256
Fax: +1 541 471 6251

www.linxtechnologies.com

Disclaimer

Linx Technologies is continually striving to improve the quality and function of its products. For this reason, we reserve the right to make changes to our products without notice. The information contained in this Data Guide is believed to be accurate as of the time of publication. Specifications are based on representative lot samples. Values may vary from lot-to-lot and are not guaranteed. "Typical" parameters can and do vary over lots and application. Linx Technologies makes no guarantee, warranty, or representation regarding the suitability of any product for use in any specific application. It is the customer's responsibility to verify the suitability of the part for the intended application. **NO LINX PRODUCT IS INTENDED FOR USE IN ANY APPLICATION WHERE THE SAFETY OF LIFE OR PROPERTY IS AT RISK.**

Linx Technologies **DISCLAIMS ALL WARRANTIES OF MERCHANTABILITY AND FITNESS FOR A PARTICULAR PURPOSE. IN NO EVENT SHALL LINX TECHNOLOGIES BE LIABLE FOR ANY OF CUSTOMER'S INCIDENTAL OR CONSEQUENTIAL DAMAGES ARISING IN ANY WAY FROM ANY DEFECTIVE OR NON-CONFORMING PRODUCTS OR FOR ANY OTHER BREACH OF CONTRACT BY LINX TECHNOLOGIES.** The limitations on Linx Technologies' liability are applicable to any and all claims or theories of recovery asserted by Customer, including, without limitation, breach of contract, breach of warranty, strict liability, or negligence. Customer assumes all liability (including, without limitation, liability for injury to person or property, economic loss, or business interruption) for all claims, including claims from third parties, arising from the use of the Products. The Customer will indemnify, defend, protect, and hold harmless Linx Technologies and its officers, employees, subsidiaries, affiliates, distributors, and representatives from and against all claims, damages, actions, suits, proceedings, demands, assessments, adjustments, costs, and expenses incurred by Linx Technologies as a result of or arising from any Products sold by Linx Technologies to Customer. Under no conditions will Linx Technologies be responsible for losses arising from the use or failure of the device in any application, other than the repair, replacement, or refund limited to the original product purchase price. Devices described in this publication may contain proprietary, patented, or copyrighted techniques, components, or materials. Under no circumstances shall any user be conveyed any license or right to the use or ownership of such items.