

CUSTOMER : _____.

DATE : FEB 15, 2013 .

REV : REV. 0.0 .

PRODUCT FAMILY DATA SHEET

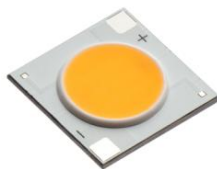

4W COB

MODEL NAME : LEMWM11 Series



CONTENTS

1. Features	3
2. Applications	3
3. Outline Dimensions	3
4. Absolute Maximum Ratings	4
5. Electro-Optical Characteristics	4
6. Flux Characteristics and Order Code	5
7. Chromaticity Bins	6 ~ 7
8. Typical Characteristic Curves	8 ~ 14
9. Reliability Test Items and Conditions	15
10. Packing and Labeling of Products	16~20
11. Cautions on Use	20~24
Appendix	25

1. Features

- External Dimensions : 14.0×14.0×1.6mm
- Internal Structure : Aluminum Base Chip on Board
- Compact High Flux Density Light Source
- Uniform High Quality Illumination
- Energy Star / ANSI Compliant Color Binning Structure with 3 SDCM Options
- UL Recognized Component (E356829)
- RoHS Compliant

2. Applications

- Bulb, Down Light, Spot Light, High Bay Light, Flood Light, Outdoor Light

3. Outline Drawings

(unit : mm)

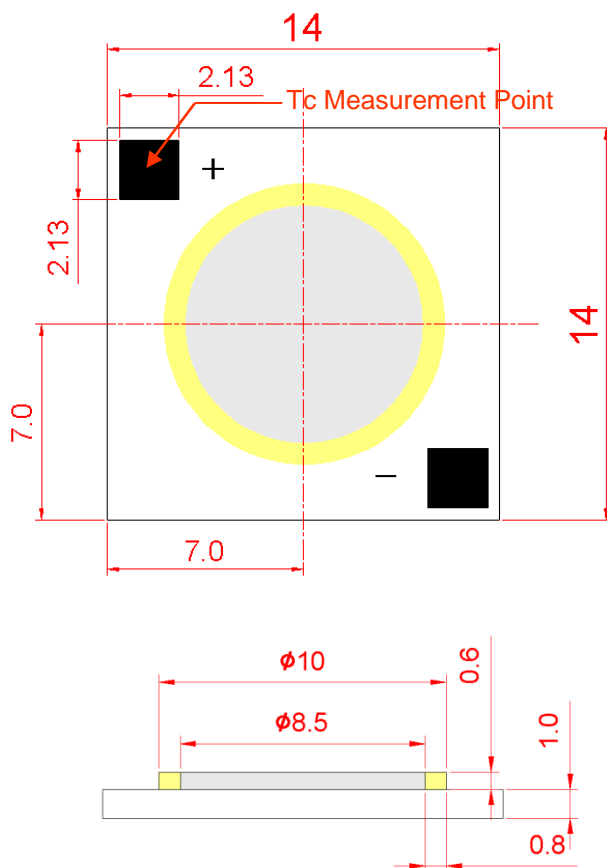

Circuit Diagram

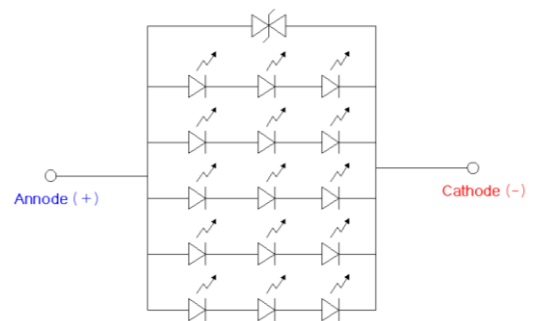

◆ Tolerances unless specified are $\pm 0.2\text{mm}$

4. Absolute Maximum Ratings

(Ta=25℃)

Items	Symbol	Rating	Unit
Forward Current	If	500	mA
Power Consumption	Pd	5.0	W
Operating Temperature	Topr	-30 ~ +95	℃
Storage Temperature	Tstg	-40 ~ +100	℃
Case Temperature *1)	Tc	95	℃
Junction Temperature *2)	Tj	120	℃

*1) Refer to '2. Outline Drawings' for Tc measurement point

*2) $T_j = T_c + R_{th\ j-c} \times P_d$

※ Operating the COB at or beyond the listed maximum ratings may affect device reliability and cause permanent damage.

※ The COBs are not designed to be driven in reverse bias.

5. Electro - Optical Characteristics

(Ta=25℃, If = 400mA)

Item	Symbol	CCT	Min.	Typ.	Max.	Unit
Luminous Flux	Φv	5700 (G)	418	456		lm
		5000 (H)	410	448		
		4000 (J)	399	437		
		3000 (L)	391	430		
		2700 (M)	372	410		
Luminous Efficacy	lm/W	5700 (G)	110	120		lm/W
		5000 (H)	108	118		
		4000 (J)	105	115		
		3000 (L)	103	113		
		2700 (M)	98	108		
Color Rendering Index	Ra	5700 (G)	78	80		-
		5000 (H)				
		4000 (J)	80	82		
		3000 (L)				
		2700 (M)				
Forward Voltage	Vf	All	9.0	9.5	10.0	V
Chromaticity Coordinates	Cx / Cy	All	Refer to 'Chromaticity Bins'			-
Viewing Angle	2Θ1/2	All	-	115	-	deg
Thermal Resistance	Rth j-c	All	-	3.8	-	℃/W

※ These values are measured by the LG Innotek optical spectrum analyzer within the following tolerances.
 Luminous Flux (Φv) : ±10%, Forward Voltage (Vf) : ±3%, Chromaticity Coordinate Value : ±0.005,
 CRI Value : ±2

6. Flux Characteristics and Order Code

Color	Min. CRI	CCT	Vf @ 400mA [V]	Luminous Flux [lm] @ 400mA			Order Code
				Bin Code	Min.	Typ.	
Cool	78	5700 (G)	9.0 ~ 10.0 (Typ. 9.5)	3	418	456	LEMWM11375GZxxxx
Cool	78	5000 (H)			410	448	LEMWM11375HZxxxx
Neutral	80	4000 (J)			399	437	LEMWM11380JZxxxx
Warm	80	3000 (L)			391	430	LEMWM11380LZxxxx
Warm	80	2700 (M)		2	372	410	LEMWM11280MZxxxx

7. Chromaticity Bins

LG Innotek complies with the ANSI C78.377A standard for its chromaticity bin structure. For each ANSI quadrangle for the CCT range of 4500K to 6500K, LG Innotek provides 4 micro bins.

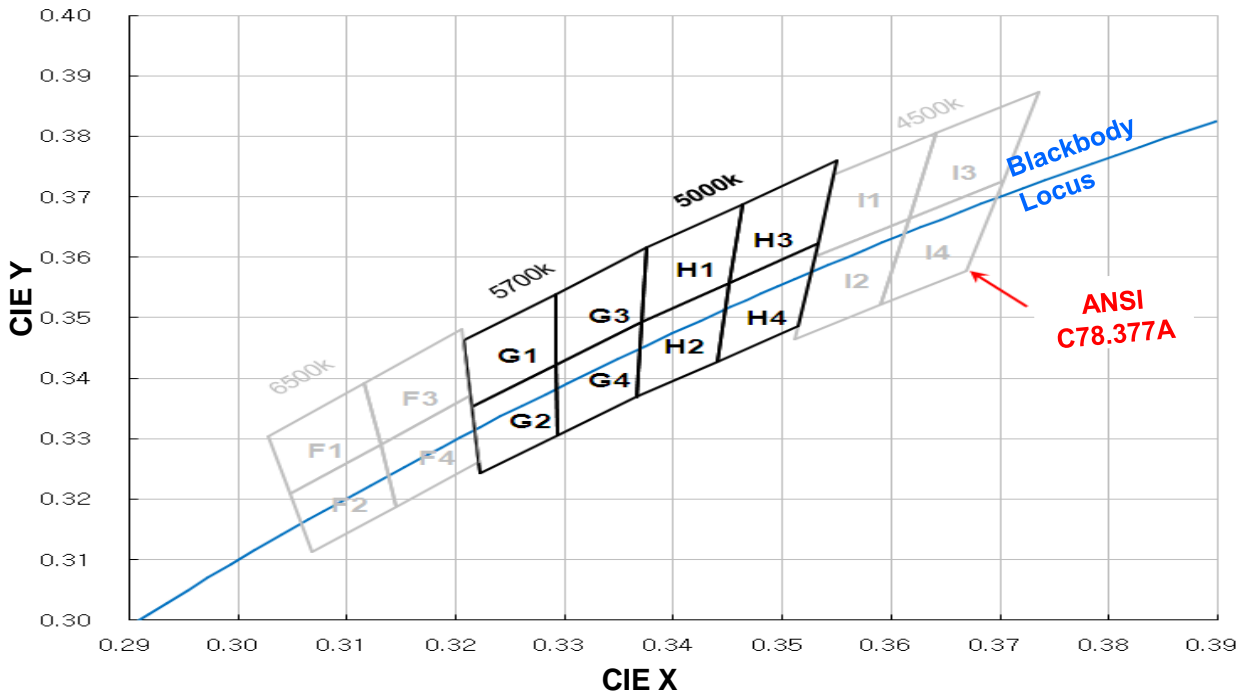

Bin	CIE X	CIE Y	Bin	CIE X	CIE Y	Bin	CIE X	CIE Y	Bin	CIE X	CIE Y
I1	0.3548	0.3736	H1	0.3376	0.3616	G1	0.3207	0.3462	F1	0.3028	0.3304
	0.3642	0.3805		0.3464	0.3688		0.3292	0.3539		0.3117	0.3393
	0.3617	0.3663		0.3452	0.3558		0.3293	0.3423		0.3131	0.3290
	0.3530	0.3601		0.3371	0.3493		0.3215	0.3353		0.3048	0.3209
I2	0.3530	0.3601	H2	0.3371	0.3493	G2	0.3215	0.3353	F2	0.3048	0.3209
	0.3617	0.3663		0.3452	0.3558		0.3293	0.3423		0.3131	0.3290
	0.3591	0.3522		0.3441	0.3428		0.3294	0.3306		0.3145	0.3187
	0.3512	0.3465		0.3366	0.3369		0.3222	0.3243		0.3068	0.3113
I3	0.3642	0.3805	H3	0.3464	0.3688	G3	0.3292	0.3539	F3	0.3117	0.3393
	0.3736	0.3874		0.3551	0.3760		0.3376	0.3616		0.3205	0.3481
	0.3703	0.3726		0.3533	0.3624		0.3371	0.3493		0.3213	0.3371
	0.3617	0.3663		0.3452	0.3558		0.3293	0.3423		0.3131	0.3290
I4	0.3617	0.3663	H4	0.3452	0.3558	G4	0.3293	0.3423	F4	0.3131	0.3290
	0.3703	0.3726		0.3533	0.3624		0.3371	0.3493		0.3213	0.3371
	0.3670	0.3578		0.3515	0.3487		0.3366	0.3369		0.3221	0.3261
	0.3591	0.3522		0.3441	0.3428		0.3294	0.3306		0.3145	0.3187

* F, I color bins are not available but can be developed within 1 month based on demand.

7. Chromaticity Bins (Continued)

LG Innotek complies with the ANSI C78.377A standard for its chromaticity bin structure. For each ANSI quadrangle for the CCT range of 2700K to 4000K, LG Innotek provides 4 micro bins. A 3 SDCM micro bin option is also available.

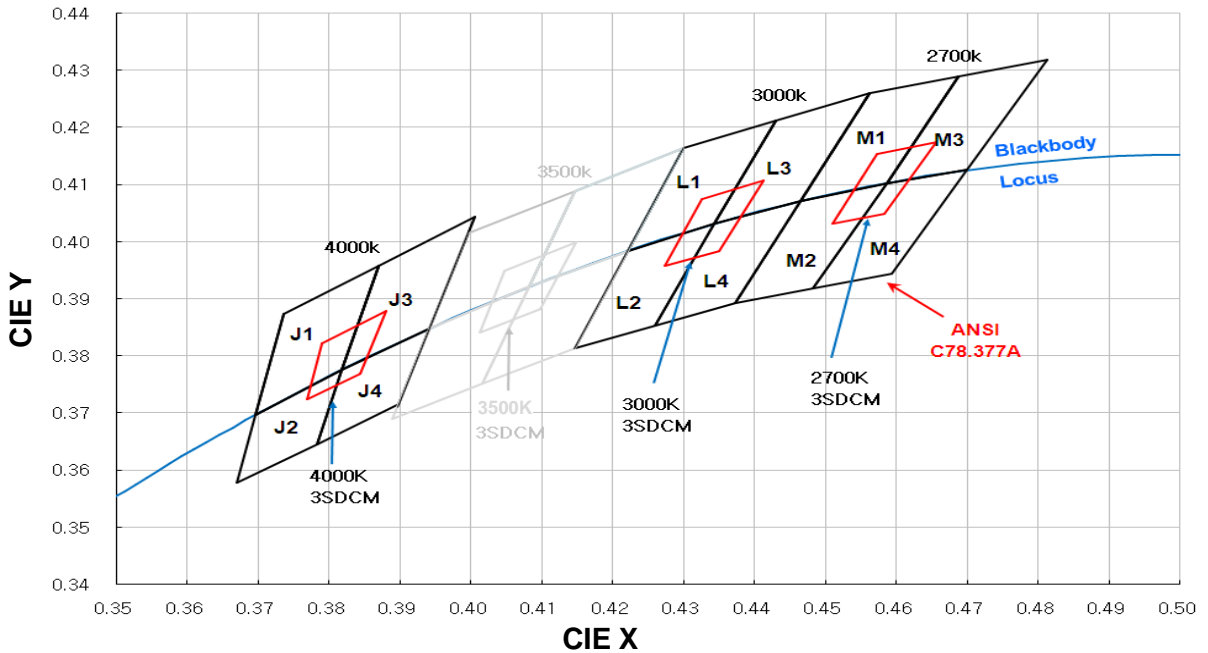

Bin	CIE X	CIE Y	Bin	CIE X	CIE Y	Bin	CIE X	CIE Y	Bin	CIE X	CIE Y
M1	0.4562	0.4260	L1	0.4299	0.4165	K1	0.3996	0.4015	J1	0.3736	0.3874
	0.4687	0.4289		0.4430	0.4212		0.4146	0.4089		0.3870	0.3958
	0.4586	0.4103		0.4344	0.4032		0.4082	0.3922		0.3819	0.3776
	0.4465	0.4071		0.4221	0.3984		0.3941	0.3848		0.3697	0.3697
M2	0.4465	0.4071	L2	0.4221	0.3984	K2	0.3941	0.3848	J2	0.3697	0.3697
	0.4586	0.4103		0.4344	0.4032		0.4082	0.3922		0.3819	0.3776
	0.4483	0.3918		0.4260	0.3853		0.4017	0.3752		0.3783	0.3646
	0.4373	0.3893		0.4147	0.3814		0.3889	0.3690		0.3670	0.3578
M3	0.4687	0.4289	L3	0.4430	0.4212	K3	0.4146	0.4089	J3	0.3870	0.3958
	0.4813	0.4319		0.4562	0.4260		0.4299	0.4165		0.4006	0.4044
	0.4700	0.4126		0.4465	0.4071		0.4221	0.3984		0.3941	0.3848
	0.4586	0.4103		0.4344	0.4032		0.4082	0.3922		0.3819	0.3776
M4	0.4586	0.4103	L4	0.4344	0.4032	K4	0.4082	0.3922	J4	0.3819	0.3776
	0.4700	0.4126		0.4465	0.4071		0.4221	0.3984		0.3941	0.3848
	0.4593	0.3944		0.4373	0.3893		0.4147	0.3814		0.3898	0.3716
	0.4483	0.3918		0.4260	0.3853		0.4017	0.3752		0.3783	0.3646
X3 (3 SDCM)	0.4656	0.4174	X3 (3 SDCM)	0.4413	0.4107	X3 (3 SDCM)	0.4148	0.4000	X3 (3 SDCM)	0.3881	0.3879
	0.4573	0.4154		0.4325	0.4075		0.4047	0.3950		0.3791	0.3823
	0.4510	0.4032		0.4274	0.3958		0.4012	0.3841		0.3769	0.3724
	0.4583	0.4049		0.4350	0.3984		0.4098	0.3883		0.3845	0.3770

* K color bin is not available but can be developed within 1 month based on demand.

8. Typical Characteristic Curves

- Forward Current vs. Forward Voltage

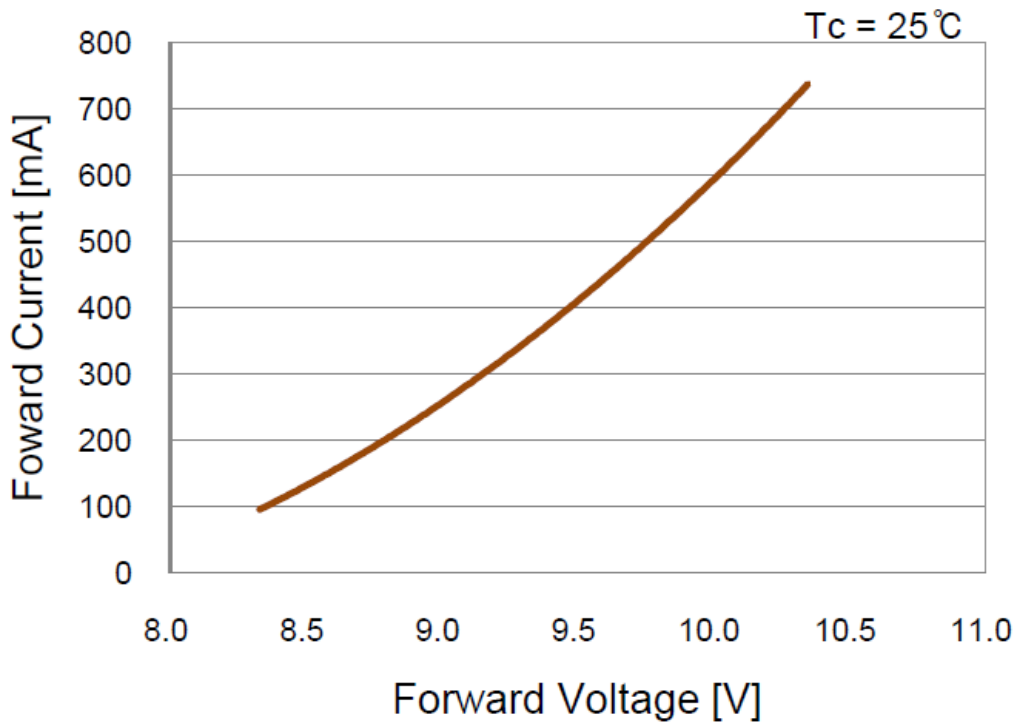

- Relative Luminous Flux vs. Forward Current

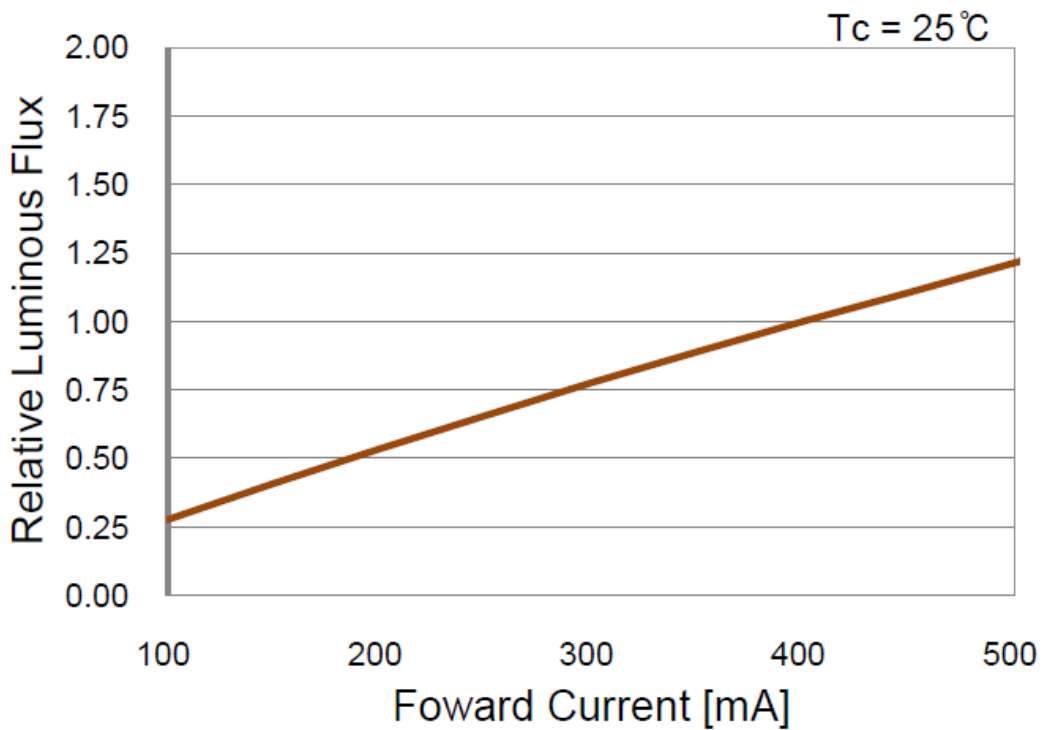

8. Typical Characteristic Curves

- Spectrum

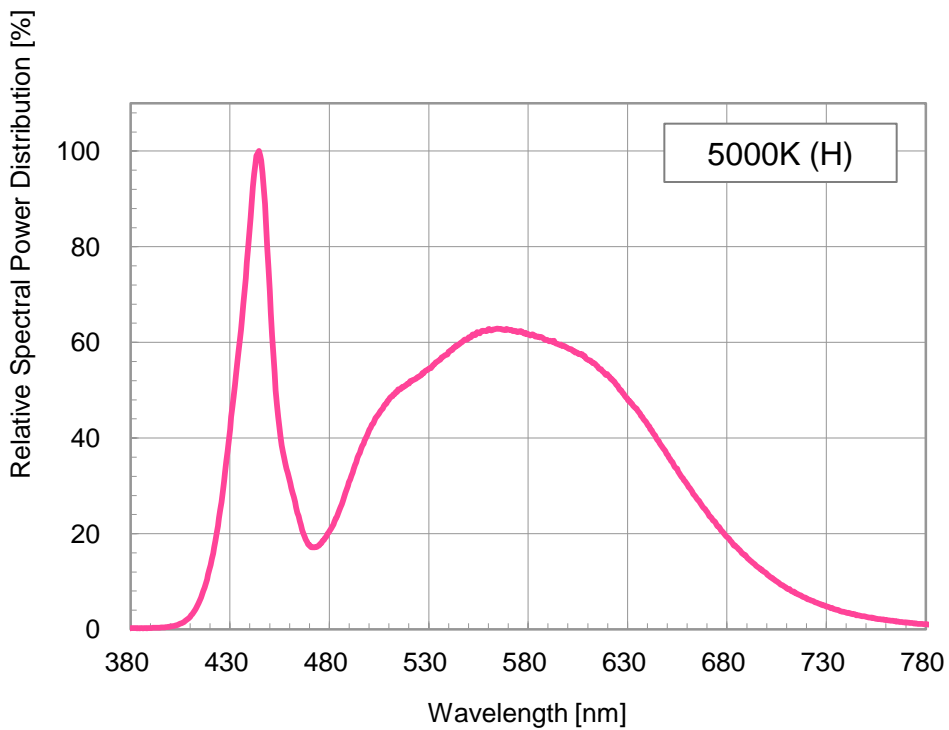
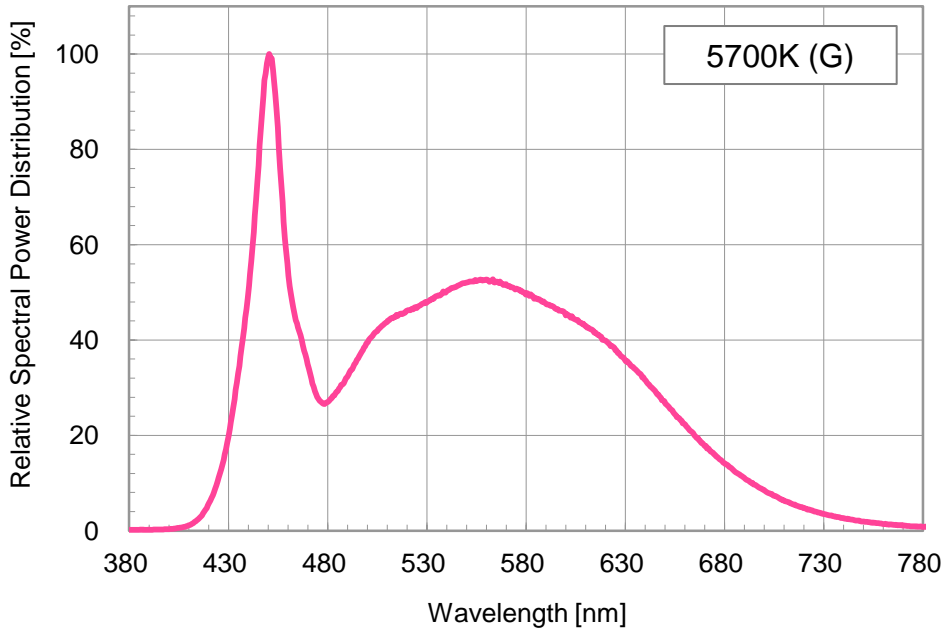

8. Typical Characteristic Curves

- Spectrum

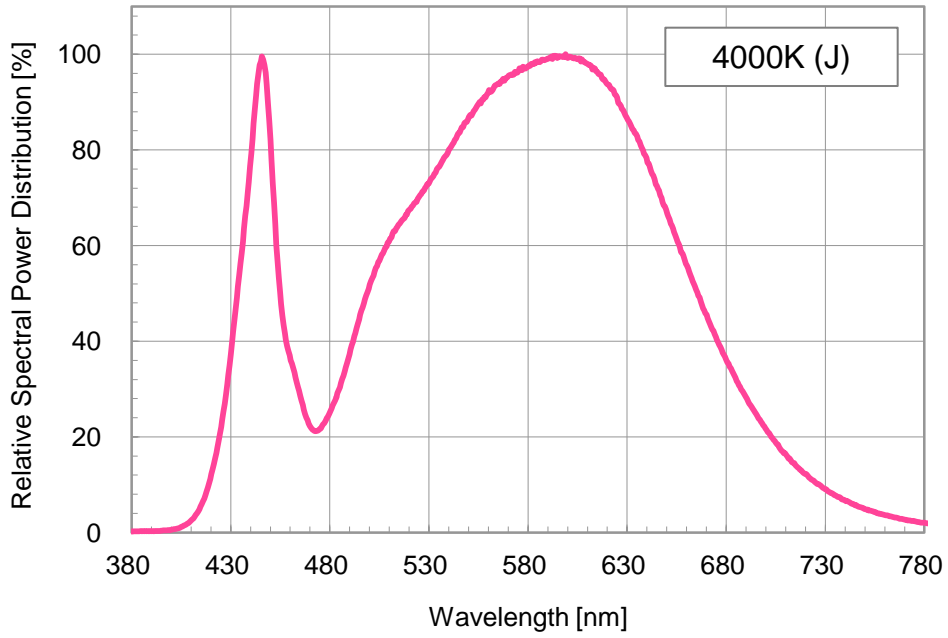

8. Typical Characteristic Curves

- Spectrum

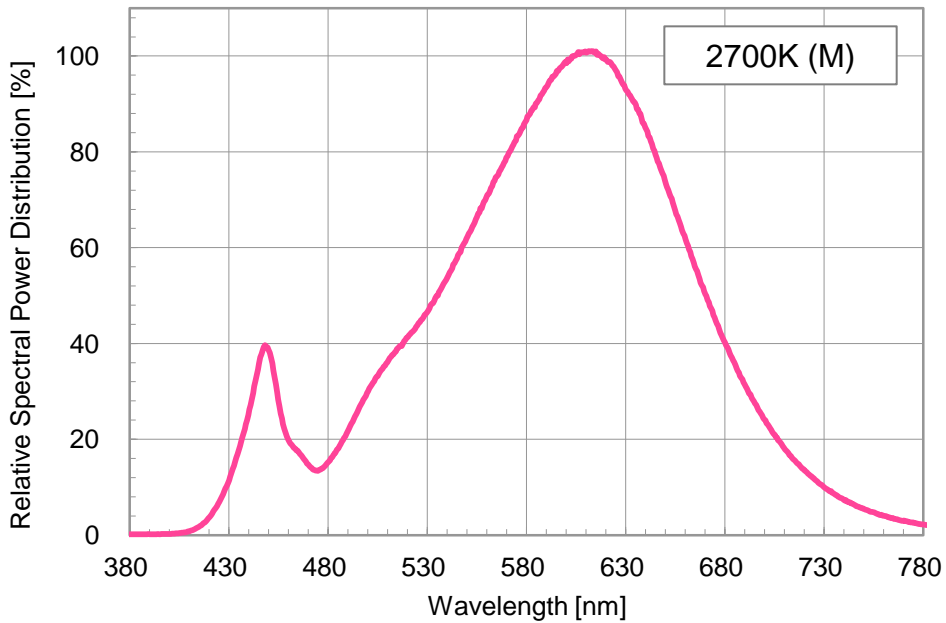
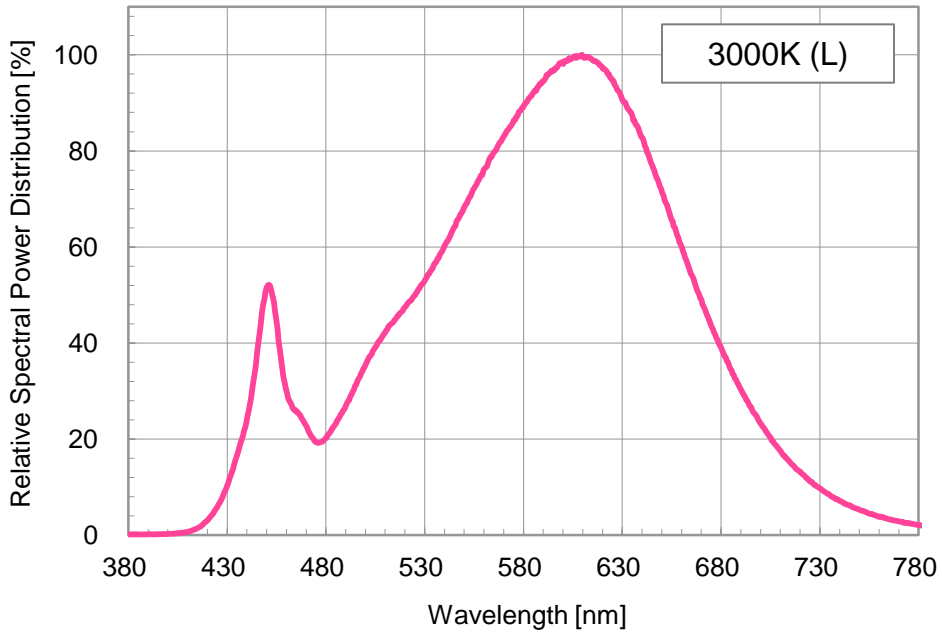

8. Typical Characteristic Curves

▪ Radiation Characteristics

If= 400mA, Ta =25 °C

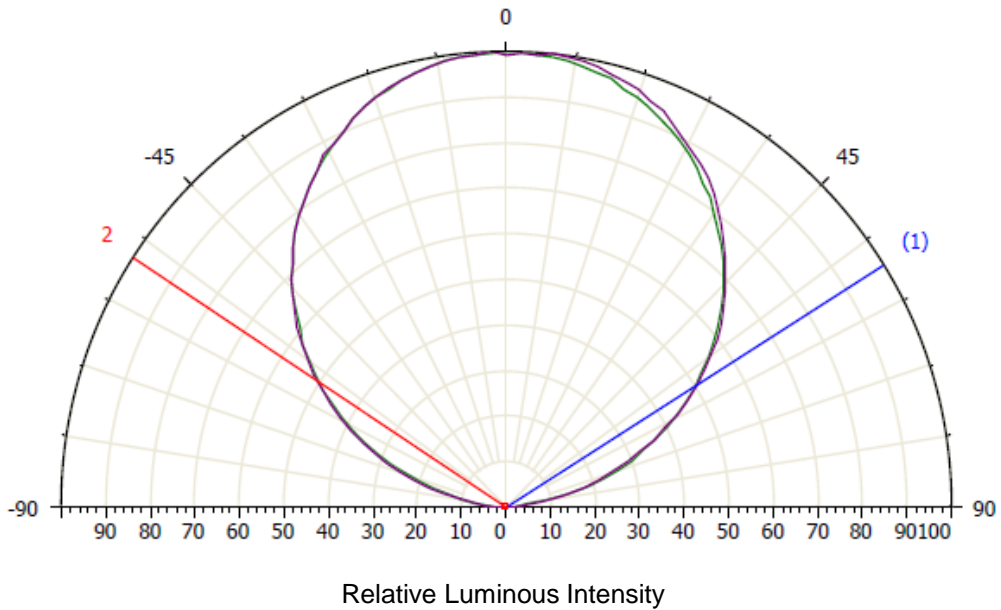

▪ Luminous Flux vs. Temperature

If= 400mA

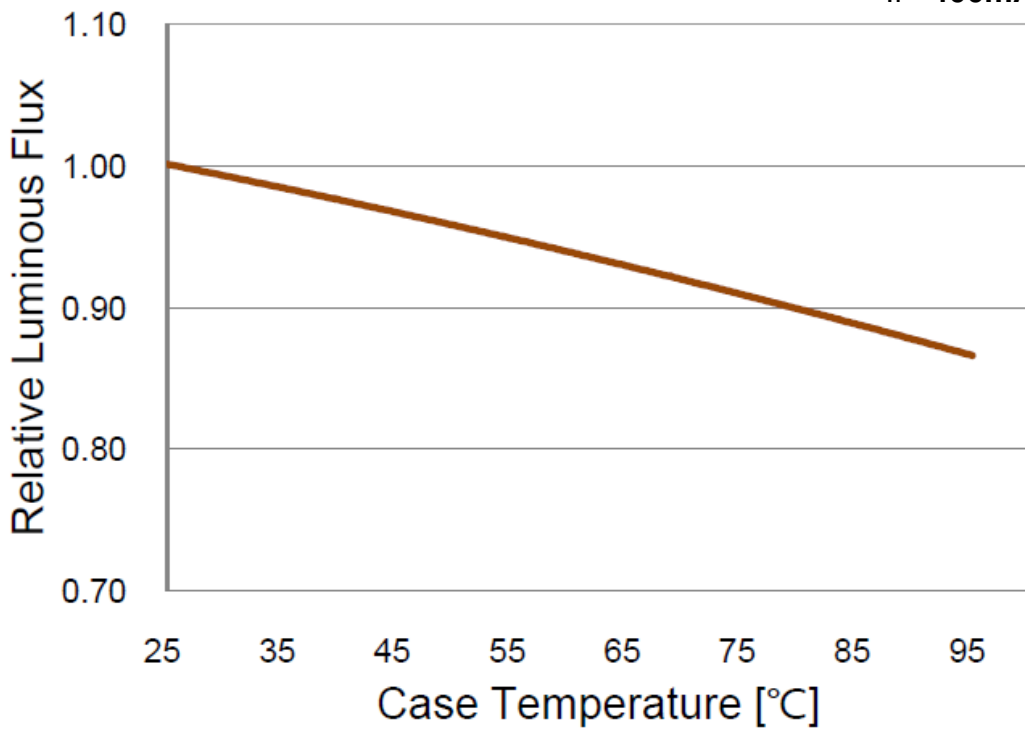

8. Typical Characteristic Curves

- Chromaticity Coordinate vs. Temperature

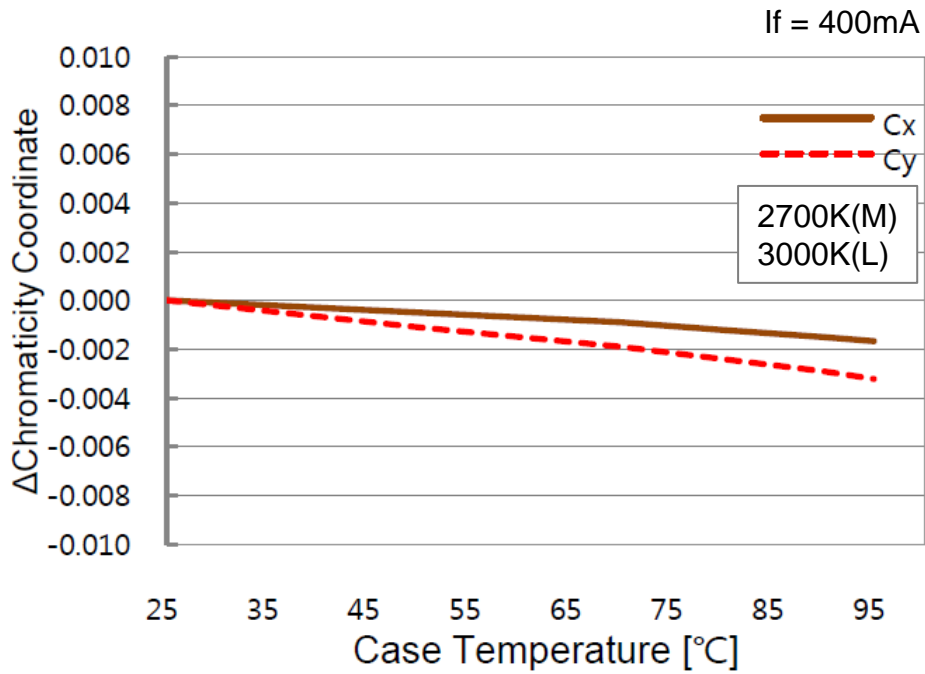
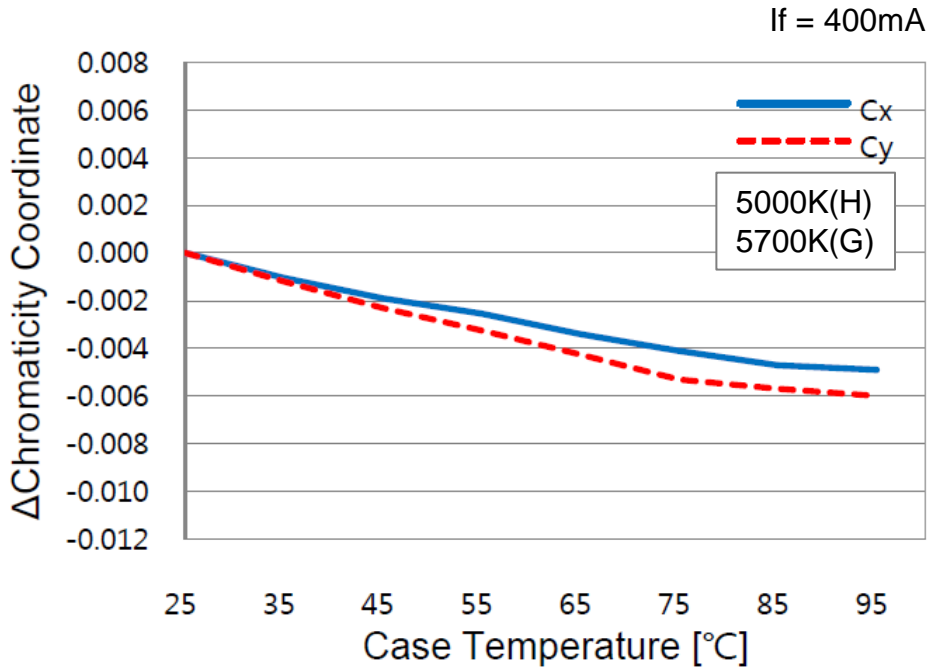

8. Typical Characteristic Curves

- Forward Voltage vs. Temperature

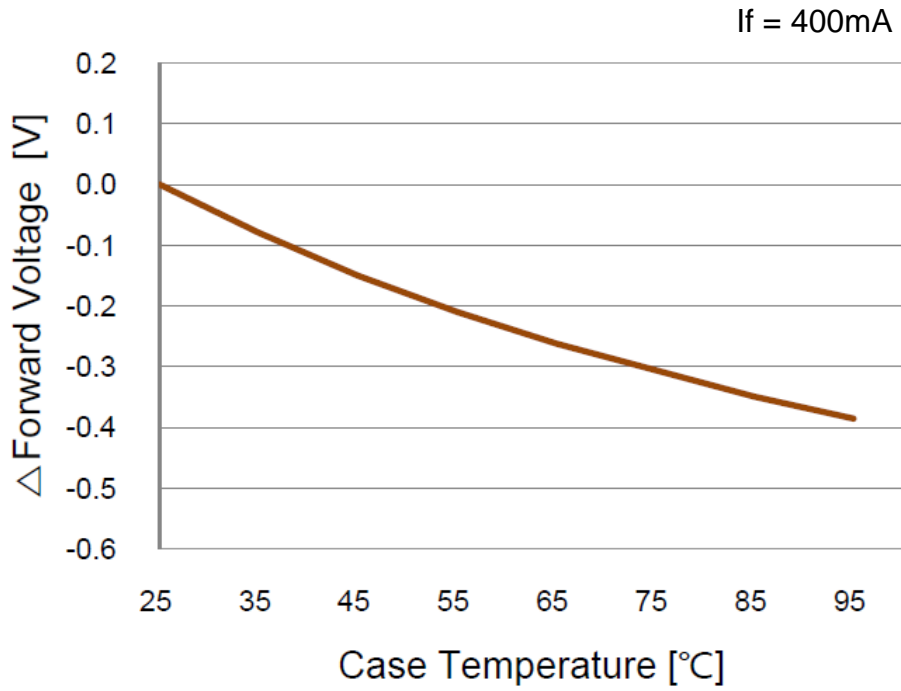

9. Reliability Test Items and Conditions

9-1. Failure Criteria

Item	Symbol	Test Condition	Limit	
			Min	Max
Forward Voltage	V _f	I _f = 400mA	-	S × 1.1
Luminous Flux	Φ _v	I _f = 400mA	S × 0.7	-

* S : Initial Value

9-2. Reliability Test

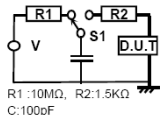
No	Item	Test Condition	Test Hours/ Cycles	SPL No	Ac/ Re
1	Steady State Operation	T _a =25℃, I _F =400 [mA]	1000 hrs	22 pcs	1 / 0
2	High Temperature / Humidity Steady State Operation	T _a =85℃, 85% RH, I _F =400 [mA]	1000 hrs	22 pcs	1 / 0
3	High Temperature Steady State Operation	T _a =85℃, I _F =400 [mA]	1000 hrs	22 pcs	1 / 0
4	Low Temperature Steady State Operation	T _a = -30℃, I _F =400 [mA]	1000 hrs	22 pcs	1 / 0
5	High Temperature Storage	100℃	1000 hrs	22 pcs	1 / 0
6	Low Temperature Storage	-40℃	1000 hrs	22 pcs	1 / 0
7	Thermal Shock	100℃ (30min) ~ -40℃ (30min)	100 cycles	22 pcs	1 / 0
8	Vibration	200m/s ² , 100~2000Hz (sweep 4min) 48min, 3 directions	4 times	22 pcs	1 / 0
9	Electrostatic Discharge (HBM, ±2kV)	 <p>R1: 10MΩ, R2: 1.5KΩ C: 100pF</p>	3 times Negative/ Positive	22 pcs	1 / 0

10. Packing and Labeling of Product

10-1. Tube Outline Dimension



- Tube Packing Material: PET (Polyethylene Terephthalate)
- Tube Dimension : 540 × 16.3 × 5.5mm
- Units per Tube : 36 units

10-2. Packing Specifications

A rubber band ties 10 tubes (with a total of 360 units) that are then packed in a vacuum sealed packing bag along with desiccants (Silica Gel). 10 packing bags (with a maximum total of 3,600 units) are packed in an inner box where 4 inner boxes are placed into an outer box (for a maximum grand total of 14,400 units).

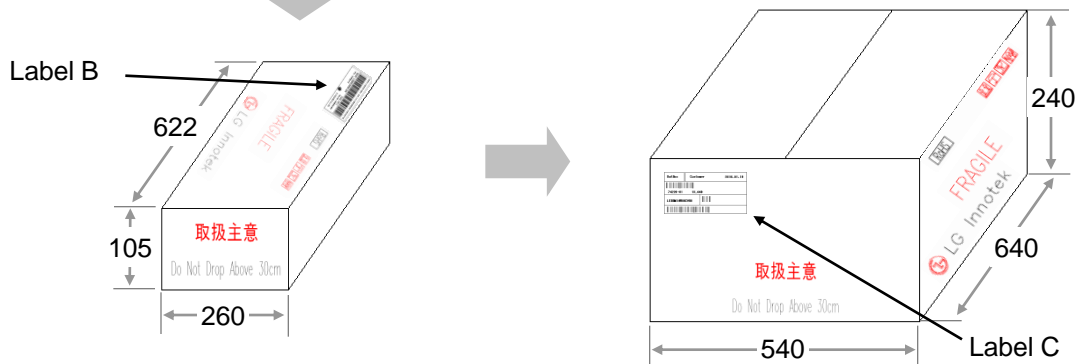
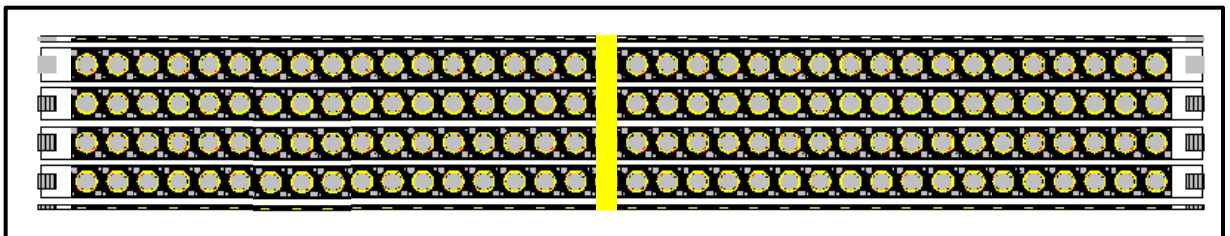

10. Packing and Labeling of Product

10-3. MES Label Structure

※ Label A (Tube Label)

Model (Company Name – manufacturing location), Date, Rank, LOT ID, Quantity

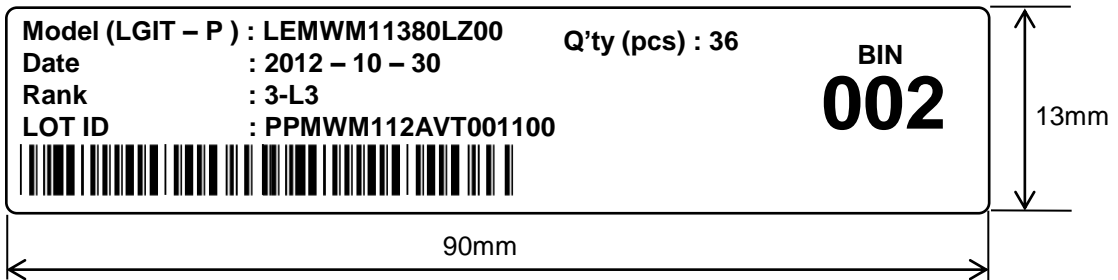

※ Label B (Packing Bag)

PACK ID, MODEL, Rank, Quantity, Run No, Rack No

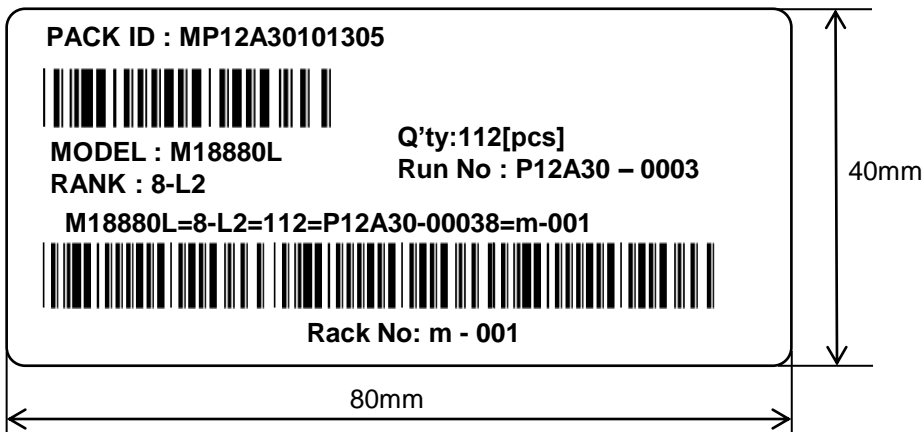

※ Label C (Inner Box Label)

INNER BOX ID, MODEL, Quantity, Date, Rank

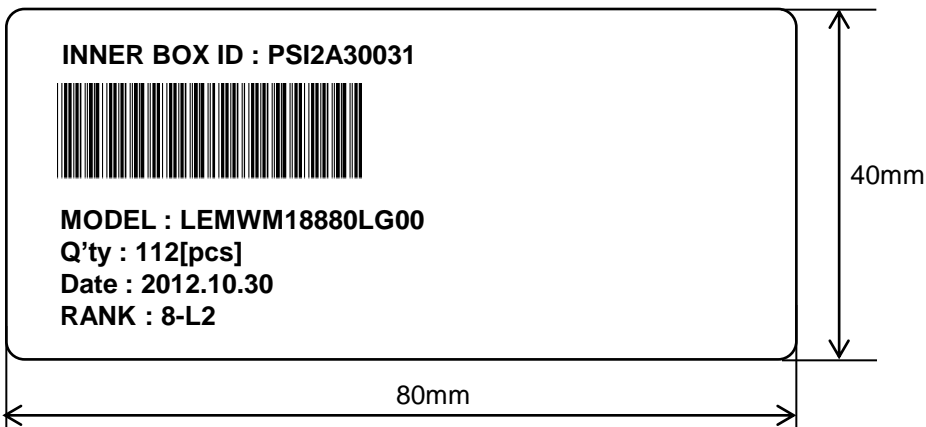

10. Packing and Labeling of Product

10-3. MES Label Structure

※ Label D (Out Box Label)

Specifying Customer, Date, Model Name, Quantity, Customer Part no, Outbox ID

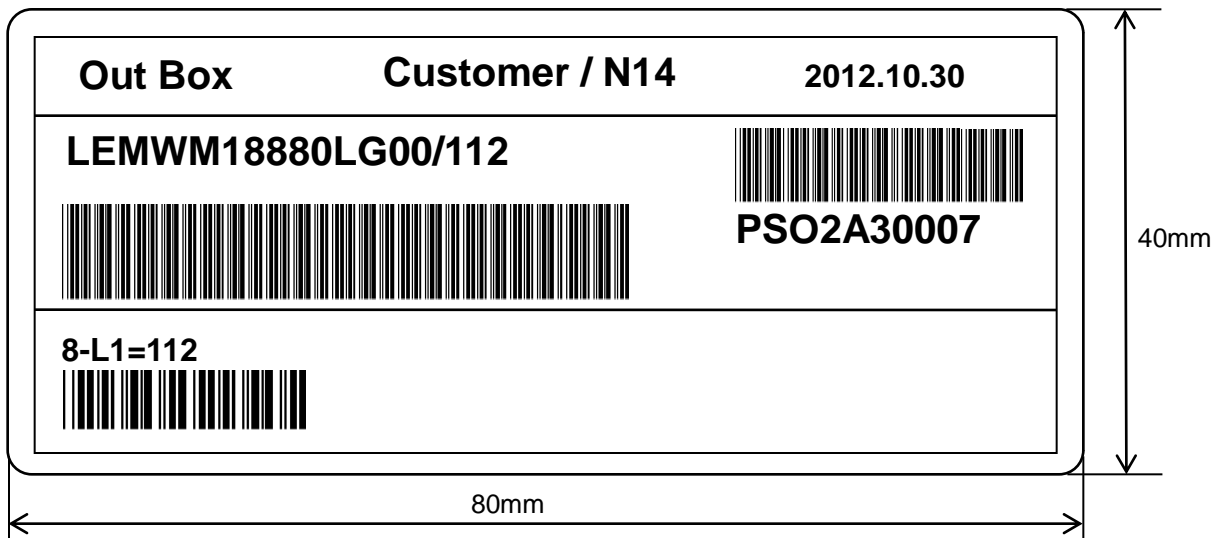

▪ Outbox ID. indication

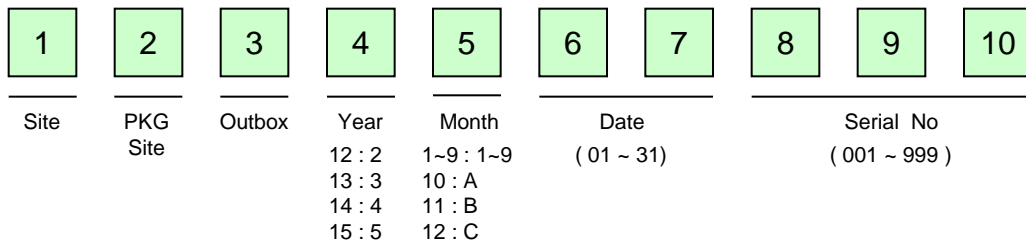

▪ Lot No. indication

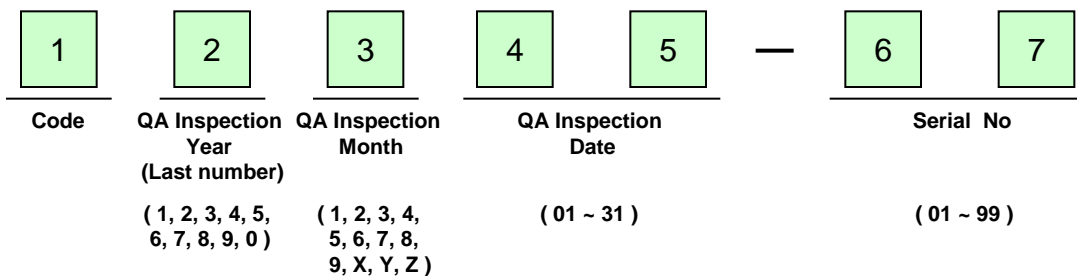

10. Packing and Labeling of Product

10-4. NEDA Label Structure

※. Label A (Tube label)

Specifying Manufacturing Part Number, Quantity, Bin Code, Lot, Date Code

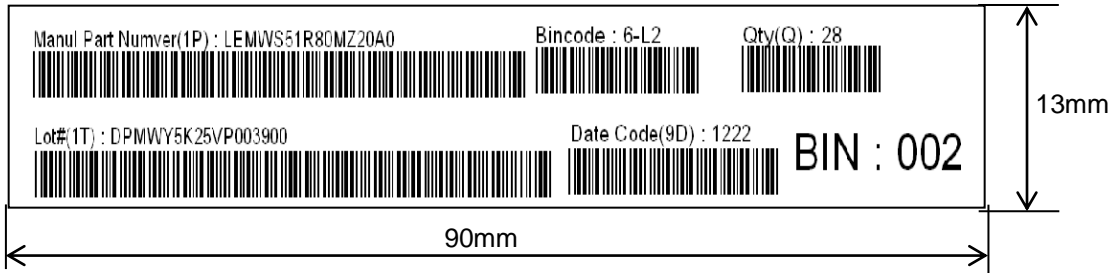

※ Label B (Sealing label)

Specifying Manufacturing Part Number, Quantity, Bin Code, Lot, Date Code and Country of Origin

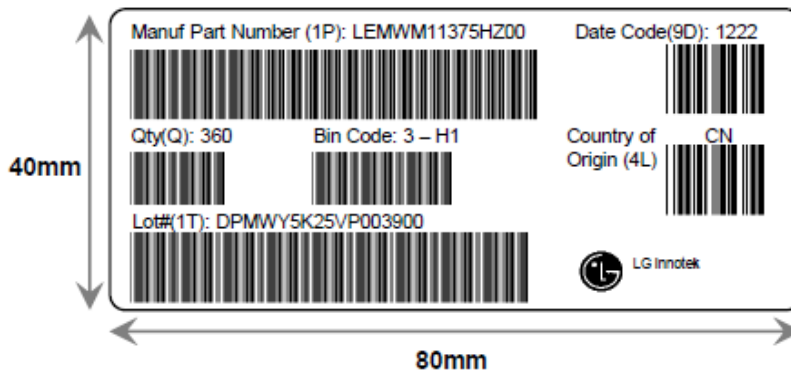

▪ Date Code(9D)

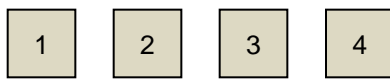

Year
01~99

Week
01~52

▪ Lot#(1T)

LG Innotek Trace Code

10. Packing and Labeling of Product

10-4. NEDA Label Structure

※ Label C (Inner)

Specifying Manufacturing Part Number, Quantity, Bin Code, Trans ID, Date Code, Country of Origin and Inner Box ID

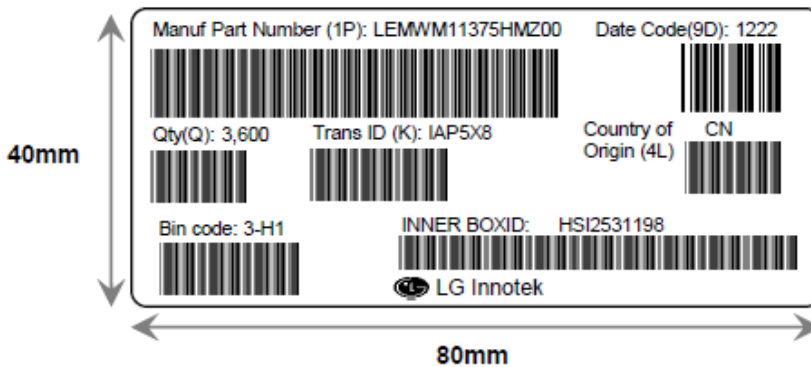

※ Label C (Outer)

Specifying Manufacturing Site, Customer Address, Manufacturing Part Number, Bin Code, Box ID, Trans ID and Quantity

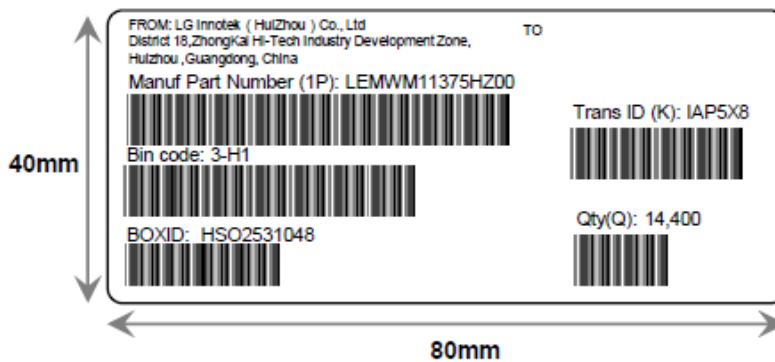

■ Box ID Indication

1	2	3	4	5	6	7	8	9	10
Site	Code	Outbox	Year	Month	Date		Serial No		
Paju: P Huizhou: H	S, P	Outbox: O Inbox: I	12 : 2 13 : 3 14 : 4 15 : 5	1~9 : 1~9 10 : A 11 : B 12 : C	(01 ~ 31)		(001 ~ 999)		

11. Cautions on Use

11-1. Overcurrent Protection

- Customers must apply current limiting devices for protection such as resistors or constant current LED drivers. Otherwise, a slight variation in voltage will cause a significant current shift where a catastrophic failure may occur.
- LG Innotek is not responsible for any damages or accidents caused if the operating or storage conditions exceed the absolute maximum ratings recommended in this document.

11-2. During Storage

- Proper temperatures and RH conditions for storage are 5 °C ~ 35 °C and RH 60%.
- Do not open the moisture-proof bag until the products are ready to be used.
- Store the products in a moisture-proof bag with desiccant (Silica gel) after opening.
- The products should be used within 168 hours after opening the bag under the recommended storage conditions.
- The products must be baked to remove moisture before using if the silica gel loses its color. Conditions for baking are 60±5°C, 20% (RH) and 24 hours maximum.

11-3. During Usage

- The product should not be directly exposed to environments containing hazardous substances.
- Please confirm performance and reliability properly if used under any of the following conditions;
 - Environments with a significant amount of moisture, dew condensation, briny air, and corrosive gas (Cl, H₂S, NH₃, SO₂, NOX, etc.)
 - Direct sunlight, outdoor exposure, and dusty locations
 - Water, oil, medical fluid, and organic solvents
- Avoid rapid transitions in ambient temperature, especially in high humidity environments where condensation can occur.
- For designing a circuit, the current through the product must not exceed the absolute maximum rating.

11. Cautions on Use

11-4. Cleaning

- Avoid cleaning, since the silicone resin is eroded by the cleaning process.

11-5. Thermal Management

- Thermal design of the end product is of paramount importance.
- Please consider how the heat generated by the product will be managed when developing the system design.
- The generation of heat is greatly impacted by the input power, the junction to case thermal resistance of the COB and the performance of the thermal interface material combined with the proximity of other components in the system.
- It is necessary to make sure that the product is operated within the maximum ratings provided in the specifications.

11-6. Static Electricity

- If a voltage exceeding the absolute maximum rating is applied to the COBs, it will damage or destroy the product. Since the COBs are sensitive to static electricity and surge, it is strongly recommended to use a wristband or anti-electrostatic glove when handling the COBs where all devices including the equipment and machinery must be properly grounded.
- It is recommended that precautions should be taken against surge voltage to the equipment that mounts the COB.
- Damaged COBs will show some unusual characteristics such as a significant increase in leakage current, lower turn-on voltage, or malfunctioning at a low current level.
- When examining the final products, it is recommended to verify whether the assembled COBs are damaged by static electricity. Damaged COBs from static electricity can be identified by conducting a light-on test or a forward voltage test at a low current.

11. Cautions on Use

11-7. Recommended Circuits

- The current through each COB must not exceed the absolute maximum rating when designing the circuits.
- The LED driver must be designed to operate the COB by forward bias only.
Reverse voltages can damage the COB.
- Reverse voltages can damage the zener diode and lead to a catastrophic failure of the COB.
- A constant current LED driver is recommended to power the COB.

11-8 Recommended Soldering Conditions

- Manual Soldering is recommended.
- Lead-free soldering shall be implemented using a maximum 40W soldering bit under the conditions of 350°C or less within 3.5 seconds.

11. Cautions on Use

11-9. Safety Guideline for Human Eyes

- Do not directly look at the light when the LEDs are on.
- Proceed with caution to avoid the risk of damage to the eyes when examining the LEDs with optical instruments.

11-10. Manual Handling

- It is recommended to wear anti-static plastic gloves to prevent damage from static electricity and dirt or other contaminants.
- When using tweezers, please handle the aluminum substrate part and avoid touching the resin part.
- For mounting, please handle the side of the aluminum part.

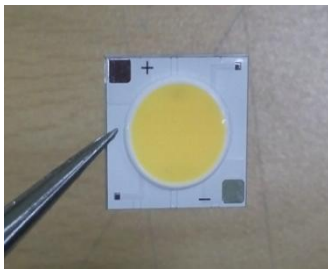

Fig.3 Proper Handling of the COB
Using Tweezers

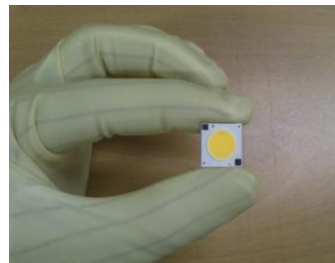

Fig.4 Proper Handling of the COB
Using Anti-Static Gloves

Appendix. Nomenclature of Package

All COBs are tested and sorted by color, luminous flux and forward voltage where every COB in a tube has only a single color bin, luminous flux bin and forward voltage bin. However, the forward voltage bin information is not captured in the part number nomenclature.

A 16-digit part number is required when orders are placed. LG Innotek leverages the following part number nomenclature.

