

**Ordering number D12114\_STRADA-S-14**

Family	Strada-S	FWHM	142+173 degrees
Type	Lens	Efficiency	94 %
LED	XP-G	cd/lm	0.320
Color	Clear	Gerber File	Available
Diameter	19.6 + 13.8 mm		
Height	6.50 mm		
Style	Rectang		
Optic Material	PMMA		
Holder Material	-		
Fastening	Screw, pin, glue		
Status	Ready		

**Ordering number DA12115\_STRADA-S-14**

Family	Strada-S	FWHM	142+173 degrees
Type	Assembly	Efficiency	94 %
LED	XP-G	cd/lm	0.320
Color	Clear	Gerber File	Available
Diameter	19.6 + 13.8 mm		
Height	6.65 mm		
Style	Rectang		
Optic Material	PMMA		
Holder Material	-		
Fastening	Screw, pin, tape		
Status	Ready		

**NOTE: The typical divergence will be changed by different color, chip size and chip position tolerance. The typical total divergence is the full angle measured where the luminous intensity is half of the peak value.**



# PRODUCT DATASHEET

## Strada-S series

last update 19/4/2012

### GENERAL INFORMATION

- Product series especially designed & optimized for XP-G series of LEDs.
- Special care taken to make light distribution as uniform as possible.
- Lens material optical grade PMMA with high UV and temperature resistance. Allows use of high current and temperature conditions.

Please find more information about used material from below:

[http://ledil.fi/sites/default/files/Documents/Technical/Material/PMMA%20N%20UL94\\_Yellow%20Card.pdf](http://ledil.fi/sites/default/files/Documents/Technical/Material/PMMA%20N%20UL94_Yellow%20Card.pdf)

<http://ledil.fi/sites/default/files/Documents/Technical/Material/PMMA%20N%20PLEXIGLAS-Datasheet.pdf>

Relative intensity of D12114\_Strada-S-14\_(XP-G)

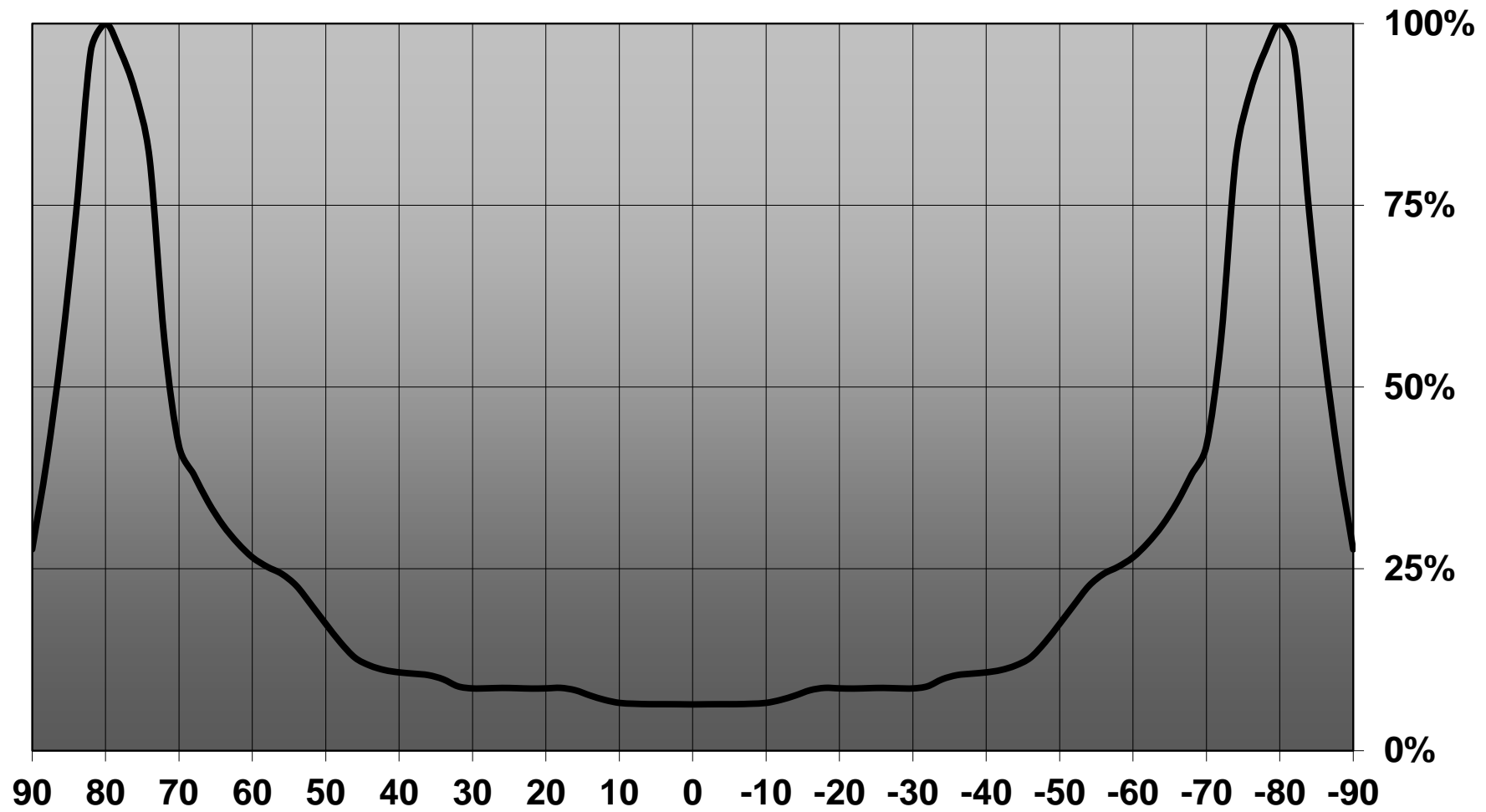

Relative intensity of DA12115\_Strada-S-14\_(XP-G)

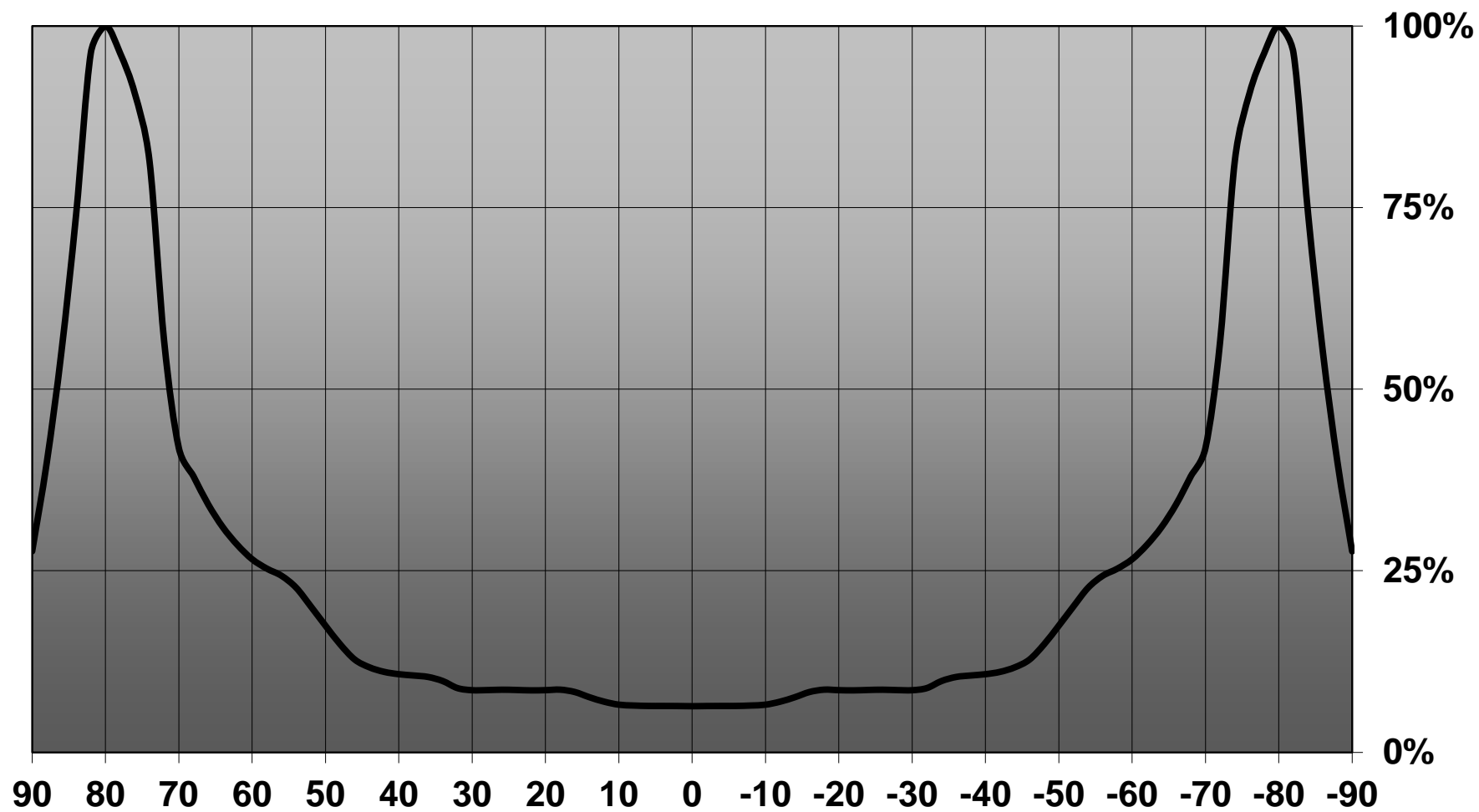

D

C

B

A

4

4

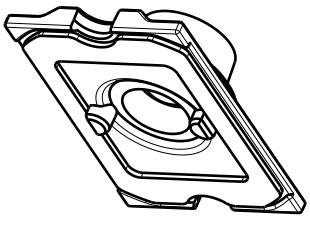

Isometric view

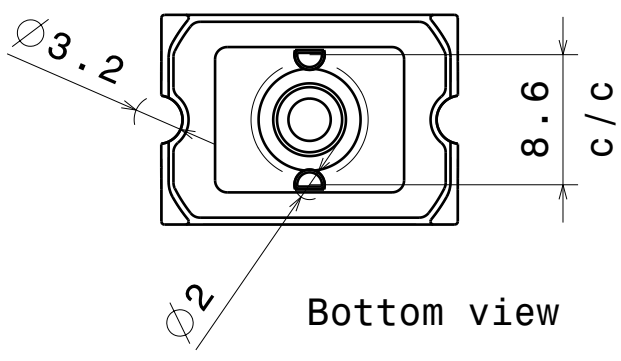

Bottom view

3

3

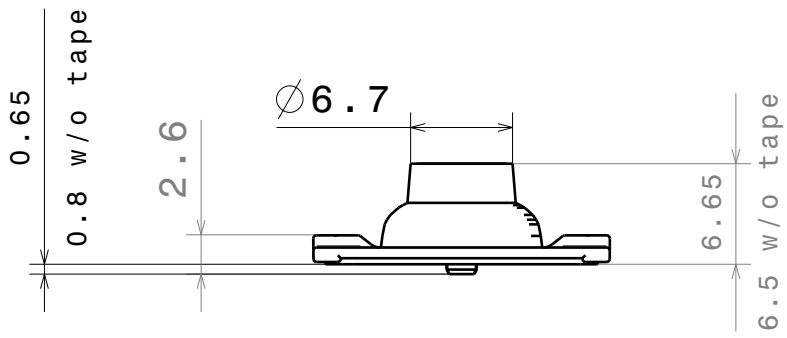

Front view

2

2

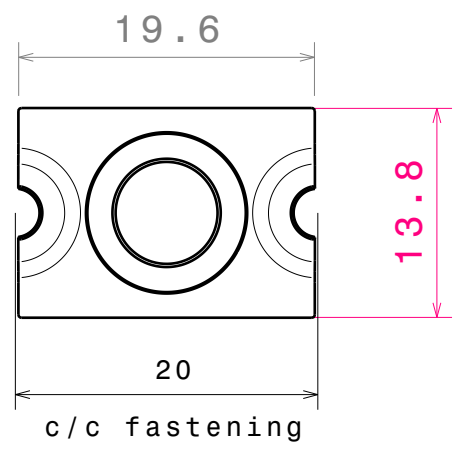

Top view

Material: Lens PMMA  
Tape: PU foam

This drawing is our property.  
It can't be reproduced  
or communicated without  
our written agreement.



Ledil Oy  
Salorankatu 10  
FIN-24100 SALO  
Finland

DRAWING TITLE

Datasheet D12114\_Strada-S

1

1

DRAWN BY ah		DATE 28.12.2011		DRAWING TITLE Datasheet D12114_Strada-S			
CHECKED BY sn		DATE 28.12.2011		SIZE A4	DRAWING NUMBER		REV 1
DESIGNED BY p1		DATE 18.4.2011		SCALE 2:1	WEIGHT (g) 1.5	SHEET 1/1	

D

A

Luminaire: Ledil Oy D12114\_STRADA-S-14\_(XP-G) Eff. 94%  
Lamps: 1 x Cree XP-G (64lm@250mA)

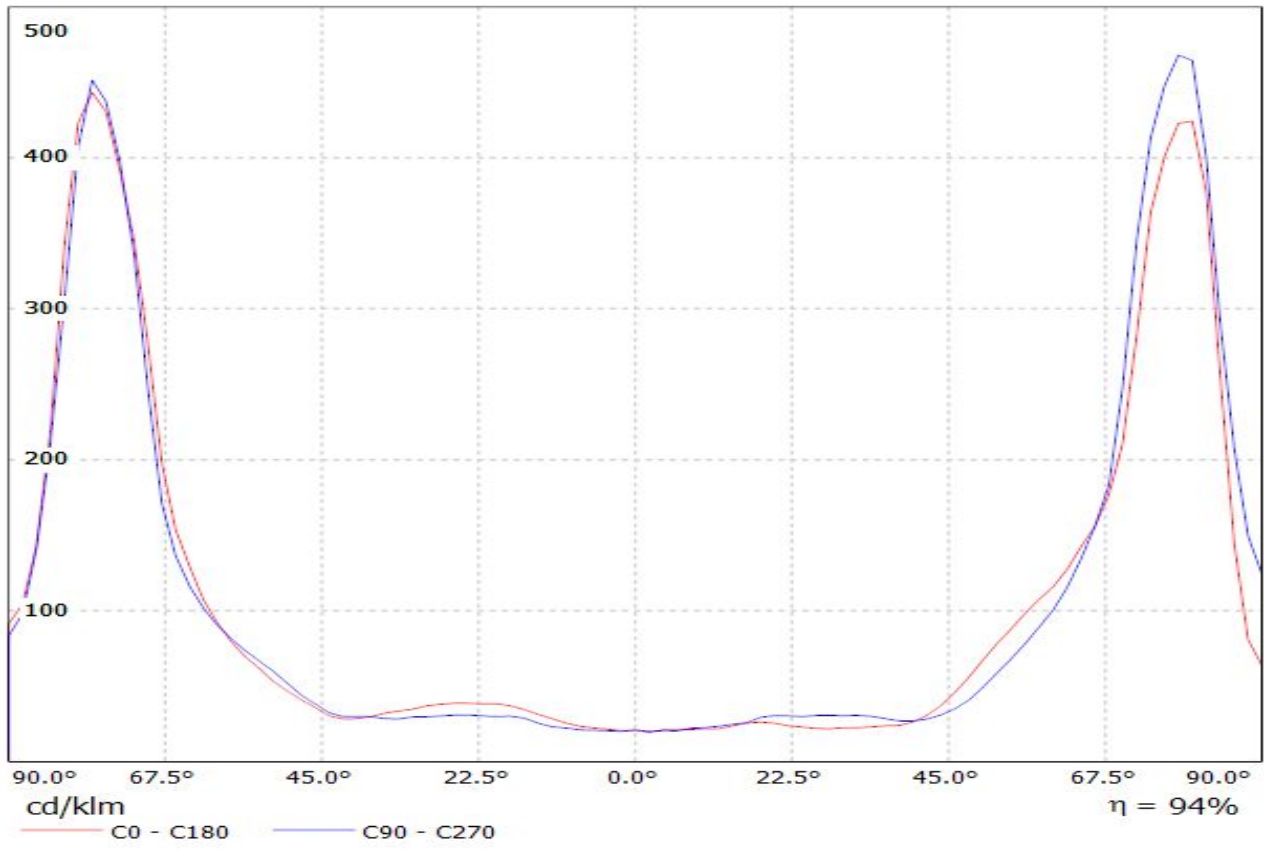

Luminaire: Ledil Oy D12114\_STRADA-S-14\_(XP-G) Eff. 94%  
Lamps: 1 x Cree XP-G (64lm@250mA)

