

# SHD CONNECTOR



Disconnectable Crimp style connectors



**Ultra-compact, double-row design**

## Features

### • Ultra-compact, low profile design

The SHD connector is compact with a mounting height of 6.3mm (.248") for top entry type and 5.5mm (.217") for side entry type, and a width of 5.0mm (.197") for top entry type and 5.1mm (.201") for side entry type.

### • Anti-misinsertion feature

Ribs and grooves on the header and receptacle prevent misinsertion and distortion during mating and unmating.

### • Receptacles with protrusions

The receptacle has protrusions on both ends for an operator to disengage the receptacle from the header without holding the wires.

### • Header designed for vacuum pick and place robotics

Although this shrouded header has locking features for its mating receptacle, there are no holes in the header shroud that would adversely effect vacuum gripping equipment. Since there is enough flat surface for secure vacuum gripping, this miniature surface mount connector is versatile for designers and economic for manufacturing.

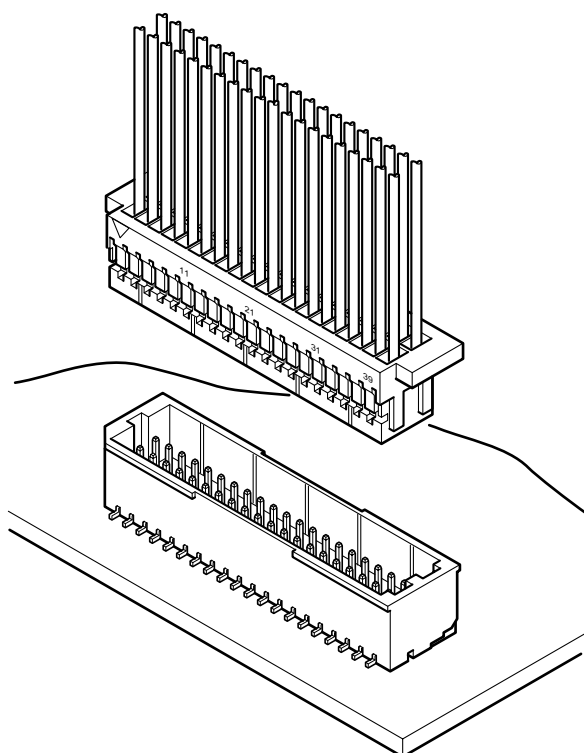

## Specifications

- Current rating: 1.0A AC, DC (AWG #28)
- Voltage rating: 50V AC, DC
- Temperature range: -25°C to +85°C  
(including temperature rise in applying electrical current)
- Contact resistance: Initial value/20m Ω max.  
After environmental testing/40m Ω max.
- Insulation resistance: 100M Ω min.
- Withstanding voltage: 500V AC/minute
- Applicable wire: AWG #32 to #28  
Insulation O.D./0.4 to 0.8mm (.016" to .031")
- \* Contact JST if Lead-Free product is required.
- \* Refer to "General Instruction and Notice when using Terminals and Connectors" at the end of this catalog.
- \* Contact JST for details.

## Standards

Ⓜ Recognized E60389

Ⓢ Certified LR20812

# SHD CONNECTOR

## Contact

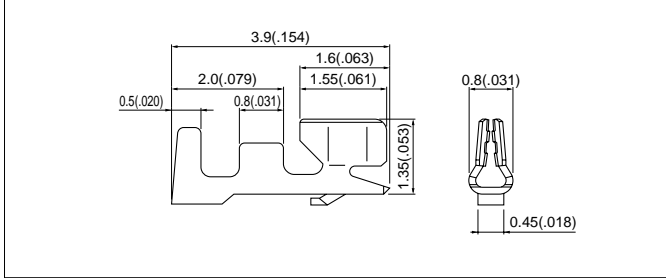

Model No.	Applicable wire			Q'ty / reel
	mm <sup>2</sup>	AWG#	Insulation O.D. mm(in.)	
<b>SSH-003GA-P0.2</b>	0.032 to 0.08	32 to 28	0.4 to 0.8(.016 to .031)	23,000

### Material and Finish

Phosphor bronze, selective gold-plated

Note: Contact JST for tin-plated contacts.

## Housing

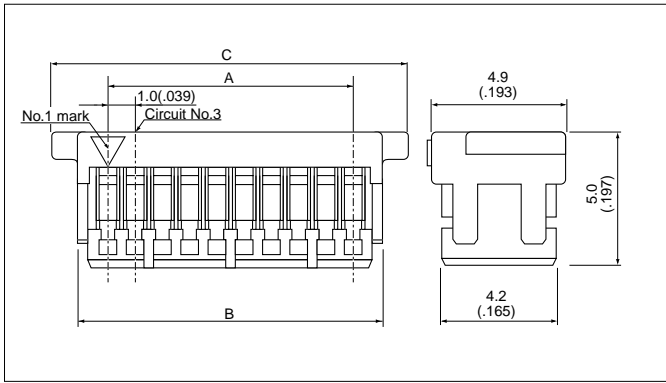

Circuits	Model No.	Dimensions mm(in.)			Q'ty / box
		A	B	C	
20	<b>SHDR-20V-S-B</b>	9.0(.354)	11.2(.441)	13.0(.512)	4,000
30	<b>SHDR-30V-S-B</b>	14.0(.551)	16.2(.638)	18.0(.709)	4,000
40	<b>SHDR-40V-S-B</b>	19.0(.748)	21.2(.835)	23.0(.906)	2,000
50	<b>SHDR-50V-S-B</b>	24.0(.945)	26.2(1.031)	28.0(1.102)	2,000

### Material

PBT, UL94V-0, natural (white)

## Shrouded header

### Top entry type

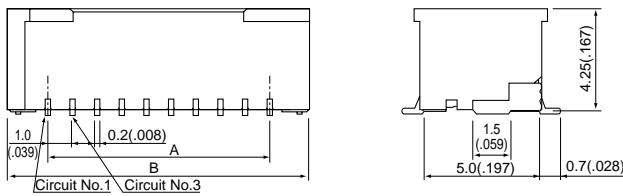

### Side entry type

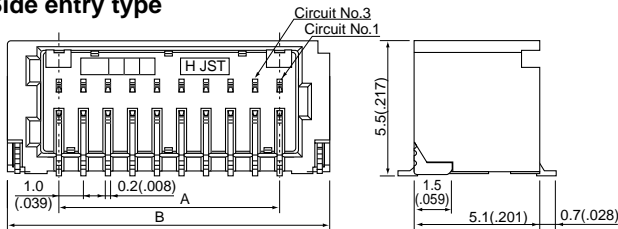

### Top entry type with a boss

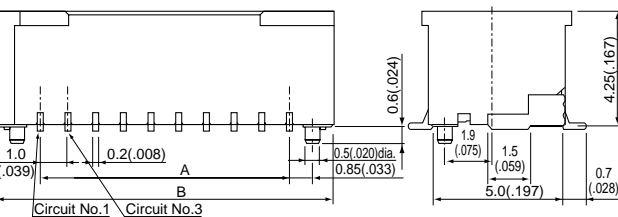

Circuits	Model No.	Dimensions mm(in.)		Q'ty / reel
		A	B	
20	<b>BM20B-SRDS-G-TF</b>	9.0(.354)	12.3(.484)	1,500
30	<b>BM30B-SRDS-G-TF</b>	14.0(.551)	17.3(.681)	1,500
40	<b>BM40B-SRDS-G-TF</b>	19.0(.748)	22.3(.878)	1,500
50	<b>BM50B-SRDS-G-TF</b>	24.0(.945)	27.3(1.075)	1,500

Circuits	Model No.	Dimensions mm(in.)		Q'ty / reel
		A	B	
20	<b>SM20B-SRDS-G-TF</b>	9.0(.354)	13.1(.516)	1,250
30	<b>SM30B-SRDS-G-TF</b>	14.0(.551)	18.1(.713)	1,250
40	<b>SM40B-SRDS-G-TF</b>	19.0(.748)	23.1(.909)	1,250
50	<b>SM50B-SRDS-G-TF</b>	24.0(.945)	28.1(1.106)	1,250

### Material and Finish

Header contact: Phosphor bronze, nickel-undercoated, gold-plated

Wafer: Glass-filled polyamide, UL94V-0, natural (ivory)

Solder tab: Brass, copper-undercoated, tin/lead-plated

Note: 1. The products listed above are supplied on embossed-tape.

2. Contact JST for the headers with tin-plated pins.

3. Contact JST for the top entry type headers with suction cap.

Circuits	Model No.	Dimensions mm(in.)		Q'ty / reel
		A	B	
20	<b>BM20B-SRDS-A-G-TF</b>	9.0(.354)	12.3(.484)	1,250
30	<b>BM30B-SRDS-A-G-TF</b>	14.0(.551)	17.3(.681)	1,250
40	<b>BM40B-SRDS-A-G-TF</b>	19.0(.748)	22.3(.878)	1,250
50	<b>BM50B-SRDS-A-G-TF</b>	24.0(.945)	27.3(1.075)	1,250

### Material and Finish

Header contact: Phosphor bronze, nickel-undercoated, gold-plated

Wafer: Glass-filled polyamide, UL94V-0, natural (ivory)

Solder tab: Brass, copper-undercoated, tin/lead-plated

Note: 1. The products listed above are supplied on embossed-tape.

2. Contact JST for the headers with tin-plated pins.

# SHD CONNECTOR

## Taping specifications

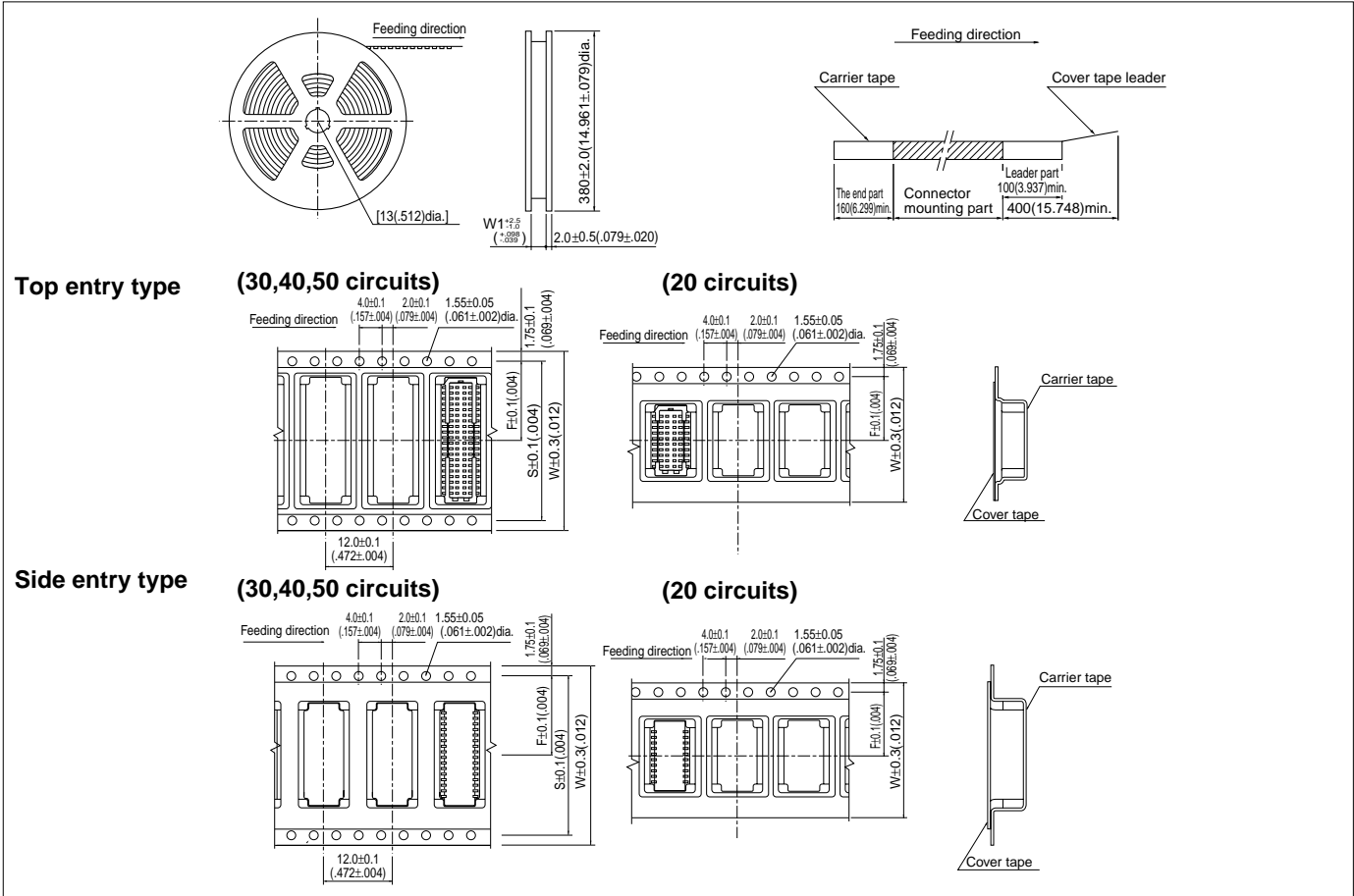

Circuits	Dimensions mm(in.)						Reel dimensions mm(in.)		Q'ty / reel	
	F		S		W		W1		Top entry type	Side entry type
	Top entry type	Side entry type	Top entry type	Side entry type	Top entry type	Side entry type	Top entry type	Side entry type		
20	11.5(.453)	11.5(.453)	-	-	24.0(.945)	24.0(.945)	25.5(1.004)	25.5(1.004)	1,500	1,250
30	14.2(.559)	14.2(.559)	28.4(1.118)	28.4(1.118)	32.0(1.260)	32.0(1.260)	33.5(1.319)	33.5(1.319)	1,500	1,250
40	20.2(.795)	20.2(.795)	40.4(1.591)	40.4(1.591)	44.0(1.732)	44.0(1.732)	45.5(1.791)	45.5(1.791)	1,500	1,250
50	20.2(.795)	20.2(.795)	40.4(1.591)	40.4(1.591)	44.0(1.732)	44.0(1.732)	45.5(1.791)	45.5(1.791)	1,500	1,250

Note: 1. Specifications conform to JIS C 0806. The tape width, connector loading recess square hole dimensions, etc. are determined by the number of circuits and external shape of the connector to be loaded.  
 2. Specifications are subject to change without prior notice.

## PC board layout (viewed from component side) and Assembly layout

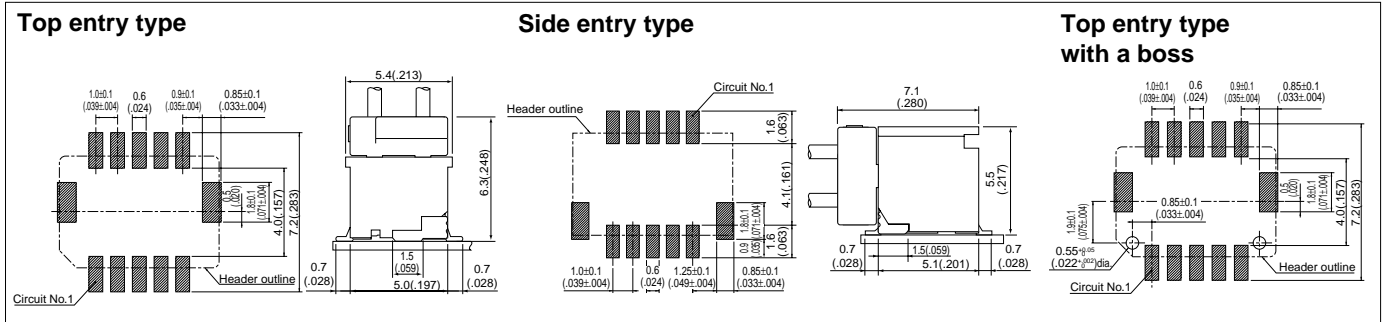

Note: 1. Tolerances are non-Cumulative:  $\pm 0.05\text{mm}$  ( $\pm 0.002''$ ) for all centers.  
 2. The dimensions above should serve as a guideline. Contact JST for details.

## Applicator for the semi-automatic press AP-K2N

Contact	Crimp applicator MKS-L-10-3		Compact crimp applicator MKS-LS		Strip-crimp applicator MKS-SC
	with safety cover	without safety cover	with safety cover	without safety cover	with safety cover
<b>SSH-003GA-P0.2</b>	APLMK SSH/L003-02	APLNC SSH/L003-02	—	—	APLSC SSH/003-02