

RING TONGUE (R type) Nylon-insulated (straight)

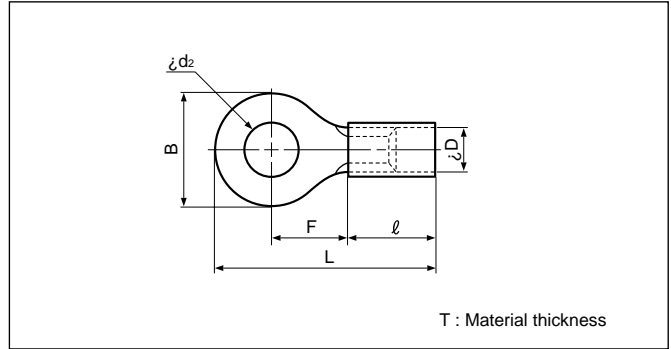

Actual
Refer to page 143 for actual size of the terminal.

T : Material thickness

File No.: E42024 LR20812 670021

| Applicable Wire AWG#(mm ²) | Stud size | | Part No. | | Standard | Dimensions mm (in.) | | | | | | Color | Tool No. | Qty/box | |
|---|-----------|----------|-----------|-------------|-------------|---------------------|--------------|--------------|-------------|----------------|---------------|---------------|----------|--|-------|
| | American | Metric | JST | JIS | | ϕd_2 | B | L | F | ℓ | ϕD | | | | T |
| 26 to 22 (0.2 to 0.5) | 1-2 | 2 | N0.5-2 | | | 2.2 (.087) | 5.2 (.205) | 16.4 (.646) | 5.8 (.228) | 8.0 (.315) | 1.9 (.075) | 0.5 (.020) | Yellow | YNT-2622 YA-1 YA-2 BCT-0514 | 1,000 |
| | 3-4 | 3 | N0.5-3 | | | 3.2 (.126) | 5.2 (.205) | 16.4 (.646) | 5.8 (.228) | | | | | | |
| | 5-6 | 3.5 | N0.5-3.7 | | | 3.7 (.146) | 6.6 (.260) | 19.0 (.748) | 7.7 (.303) | | | | | | |
| | 8 | 4 | N0.5-4 | | | 4.3 (.169) | 6.6 (.260) | 19.0 (.748) | 7.7 (.303) | | | | | | |
| 22 to 16 (0.25 to 1.65) | 10 | 5 | N0.5-5 | | | 5.3 (.209) | 8.0 (.315) | 19.0 (.748) | 7.0 (.276) | 9.0 (.354) | 3.2 (.126) | 0.8 (.031) | Red | YNT-2216 YA-1 YA-2 YA-4 BCT-0514 | 1,000 |
| | 1-2 | 2 | N1.25-2 | | | 2.2 (.087) | 5.5 (.217) | 15.7 (.618) | 4.0 (.157) | | | | | | |
| | 3-4 | 3 | N1.25-3 | RAP1.25-3 | | 3.2 (.126) | 5.5 (.217) | 15.7 (.618) | 4.0 (.157) | | | | | | |
| | 3-4 | 3 | N1.25-MS3 | | | 3.2 (.126) | 5.5 (.217) | 17.4 (.685) | 5.6 (.220) | | | | | | |
| | 3-4 | 3 | N1.25-L3 | | | 3.2 (.126) | 8.0 (.315) | 20.0 (.787) | 7.0 (.276) | | | | | | |
| | 5-6 | 3.5 | N1.25-3.7 | | | 3.7 (.146) | 5.5 (.217) | 15.7 (.618) | 4.0 (.157) | | | | | | |
| | 5-6 | 3.5 | N1.25-M3 | RAP1.25-3.5 | | 3.7 (.146) | 6.6 (.260) | 18.6 (.732) | 6.3 (.248) | | | | | | |
| | 8 | 4 | N1.25-M4 | | | 4.3 (.169) | 6.6 (.260) | 18.6 (.732) | 6.3 (.248) | | | | | | |
| | 8 | 4 | N1.25-4 | RAP1.25-4 | | 4.3 (.169) | 8.0 (.315) | 20.0 (.787) | 7.0 (.276) | | | | | | |
| | 10 | 5 | N1.25-5 | RAP1.25-5 | | 5.3 (.209) | 8.0 (.315) | 20.0 (.787) | 7.0 (.276) | | | | | | |
| | 1/4 | 6 | N1.25-6 | | | 6.4 (.252) | 11.6 (.457) | 25.9 (1.020) | 11.1 (.437) | | | | | | |
| | 5/16 | 8 | N1.25-8 | | | 8.4 (.331) | 11.6 (.457) | 25.9 (1.020) | 11.1 (.437) | | | | | | |
| 3/8 | 10 | N1.25-10 | | | 10.5 (.413) | 13.6 (.535) | 29.7 (1.169) | 13.9 (.547) | 500 | | | | | | |
| 16 to 14 (1.04 to 2.63) | 1-2 | 2 | N2-S2 | | | 2.2 (.087) | 6.4 (.252) | 16.5 (.650) | 4.3 (.169) | 9.0 (.354) | 3.9 (.153) | 0.8 (.031) | Blue | YNT-1614 YA-1 YA-2 YA-4 BCT-0514 | 500 |
| | 3-4 | 3 | N2-MS3 | | | 3.2 (.126) | 5.5 (.217) | 17.4 (.685) | 5.6 (.220) | | | | | | |
| | 3-4 | 3 | N2-S3.3 | | | 3.2 (.126) | 6.4 (.252) | 16.5 (.650) | 4.3 (.169) | | | | | | |
| | 3-4 | 3 | N2-3 | | | 3.2 (.126) | 8.5 (.335) | 21.0 (.827) | 7.8 (.307) | | | | | | |
| | 5-6 | 3.5 | N2-S3 | | | 3.7 (.146) | 6.4 (.252) | 16.5 (.650) | 4.3 (.169) | | | | | | |
| | 5-6 | 3.5 | N2-M3 | RAP2-3.5 | | 3.7 (.146) | 6.6 (.260) | 18.6 (.732) | 6.3 (.248) | | | | | | |
| | 5-6 | 3.5 | N2-P3.5 | | | 3.7 (.146) | 7.0 (.276) | 20.2 (.780) | 7.7 (.303) | | | | | | |
| | 8 | 4 | N2-M4 | | | 4.3 (.169) | 6.6 (.260) | 18.6 (.732) | 6.3 (.248) | | | | | | |
| | 8 | 4 | N2-P4 | | | 4.3 (.169) | 7.0 (.276) | 20.2 (.800) | 7.7 (.303) | | | | | | |
| | 8 | 4 | N2-4 | RAP2-4 | | 4.3 (.169) | 8.5 (.335) | 21.0 (.827) | 7.8 (.307) | | | | | | |
| | 10 | 5 | N2-M5 | | | 5.3 (.209) | 8.5 (.335) | 21.0 (.827) | 7.8 (.307) | | | | | | |
| | 10 | 5 | N2-5 | RAP2-5 | | 5.3 (.209) | 9.5 (.374) | 21.0 (.827) | 7.3 (.287) | | | | | | |
| | 1/4 | 6 | N2-6 | RAP2-6 | | 6.4 (.252) | 12.0 (.472) | 26.0 (1.024) | 11.0 (.433) | | | | | | |
| | 5/16 | 8 | N2-8 | RAP2-8 | | 8.4 (.331) | 12.0 (.472) | 26.0 (1.024) | 11.0 (.433) | | | | | | |
| | 3/8 | 10 | N2-10 | | | 10.5 (.413) | 13.6 (.535) | 29.7 (1.169) | 13.9 (.547) | | | | | | |
| | 1/2 | 12 | N2-12 | | | 13.0 (.512) | 19.0 (.748) | 35.2 (1.386) | 16.7 (.657) | | | | | | |
| | 1/2 | 14 | N2-14 | | | 15.0 (.591) | 27.0 (1.063) | 43.7 (1.720) | 21.2 (.835) | | | | | | |
| | 5/8 | 16 | N2-16 | | | 17.0 (.669) | 27.0 (1.063) | 43.7 (1.720) | 21.2 (.835) | | | | | | |
| 3/4 | 20 | N2-20 | | | 21.0 (.827) | 27.0 (1.063) | 43.7 (1.720) | 21.2 (.835) | | | | | | | |
| 12 to 10 (2.63 to 6.64) | 3-4 | 3 | N5.5-3 | | | 3.2 (.126) | 9.5 (.374) | 26.5 (1.403) | 8.3 (.327) | 13.5 (.531) | 5.4 (.213) | 1.0 (.039) | Yellow | YNT-1210S YA-4 BCT-0514 | 500 |
| | 5-6 | 3.5 | N5.5-S3 | | | 3.7 (.146) | 7.2 (.283) | 23.0 (.906) | 5.9 (.232) | | | | | | |
| | 8 | 4 | N5.5-S4 | | | 4.3 (.169) | 7.2 (.283) | 23.0 (.906) | 5.9 (.232) | | | | | | |
| | 8 | 4 | N5.5-4 | RAP5.5-4 | | 4.3 (.169) | 9.5 (.374) | 26.5 (1.043) | 8.3 (.327) | | | | | | |
| | 10 | 5 | N5.5-5 | RAP5.5-5 | | 5.3 (.209) | 9.5 (.374) | 26.5 (1.043) | 8.3 (.327) | | | | | | |
| | 10 | 5 | N5.5-S5 | | | 5.3 (.209) | 13.2 (.520) | 29.1 (1.146) | 9.0 (.354) | | | | | | |
| | 1/4 | 6 | N5.5-6 | RAP5.5-6 | | 6.4 (.252) | 12.0 (.472) | 32.5 (1.280) | 13.0 (.512) | | | | | | |
| | 1/4 | 6 | N5.5-S6 | | | 6.4 (.252) | 13.2 (.520) | 29.1 (1.146) | 9.0 (.354) | | | | | | |
| | 5/16 | 8 | N5.5-S8 | | | 8.4 (.331) | 13.2 (.520) | 29.1 (1.146) | 9.0 (.354) | | | | | | |
| | 5/16 | 8 | N5.5-8 | RAP5.5-8 | | 8.4 (.331) | 15.0 (.591) | 34.7 (1.366) | 13.7 (.539) | | | | | | |
| | 3/8 | 10 | N5.5-10 | RAP5.5-10 | | 10.5 (.413) | 15.0 (.591) | 34.7 (1.366) | 13.7 (.539) | | | | | | |
| | 1/2 | 12 | N5.5-12 | | | 13.0 (.512) | 19.2 (.756) | 39.1 (1.539) | 16.0 (.630) | | | | | | |
| | 1/2 | 14 | N5.5-14 | | | 15.0 (.591) | 32.0 (1.260) | 54.8 (2.157) | 25.3 (.996) | | | | | | |
| | 5/8 | 16 | N5.5-16 | | | 17.0 (.669) | 32.0 (1.260) | 54.8 (2.157) | 25.3 (.996) | | | | | | |
| | 11/16 | 18 | N5.5-18 | | | 19.0 (.748) | 32.0 (1.260) | 54.8 (2.157) | 25.3 (.996) | | | | | | |
| | 3/4 | 20 | N5.5-20 | | | 21.0 (.827) | 32.0 (1.260) | 54.8 (2.157) | 25.3 (.996) | | | | | | |

Note:1) Products with the JIS mark conform to JIS C2805.

2) *The crimping will be more secure if the total cross-sectional area of the wire is at least 0.5 mm².

Examples: If the cross-sectional area of the wire is 0.3mm², fold the wire in two when crimping the terminal.

If the cross-sectional area of the wire is 0.5mm², crimp the terminal onto the wire as it is.

3) Because nylon absorbs moisture, care must be taken concerning storage.

4) The part numbers indicated in the above table are for products with a brazed seam.

When ordering products with a butted seam, add the prefix "WS" to the part number (ex. N2-4 → **NWS2-4**).

5) Delivery lead times may vary depending on the product. Contact JST for details.

Solderless terminals



RING TONGUE (R type) Nylon-insulated (flared)

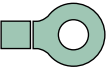

Actual

Refer to page 144 for actual size of the terminal.

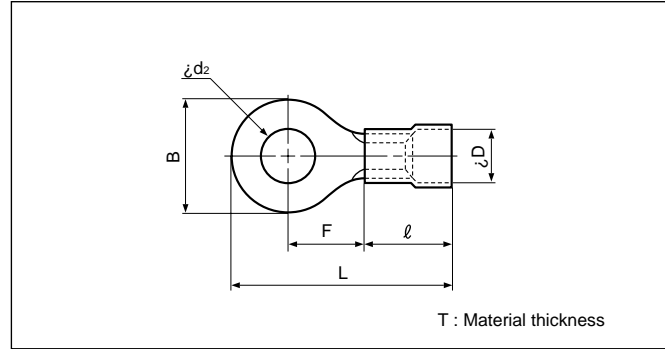

File No.: E42024 LR20812 670021

| Applicable Wire AWG#(mm ²) | Stud size | | Part No. | | Standard | Dimensions mm (in.) | | | | | | Color | Tool No. | Qty/box | |
|---|----------------------------|--------|------------|-------------|----------|---------------------|--------------|--------------|--------------|---------------|----------------|---------------|---------------|--|-------------------------------|
| | American | Metric | JST | JIS | | ø d ₂ | B | L | F | ℓ | ø D | | | | T |
| 26 to 22 (0.2 to 0.5) | 1-2 | 2 | FN0.5-2 | | | 2.2 (.087) | 5.2 (.205) | 16.7 (.658) | 5.8 (.228) | 8.3 (.315) | 2.9 (.114) | 0.5 (.020) | Yellow | YNT-2622 YA-1 YA-2 BCT-0514 | 1,000 |
| | 3-4 | 3 | FN0.5-3 | | | 3.2 (.126) | 5.2 (.205) | 16.7 (.658) | 5.8 (.228) | | | | | | |
| | 5-6 | 3.5 | FN0.5-3.7 | | | 3.7 (.146) | 6.6 (.260) | 19.3 (.760) | 7.7 (.303) | | | | | | |
| | 8 | 4 | FN0.5-4 | | | 4.3 (.169) | 6.6 (.260) | 19.3 (.760) | 7.7 (.303) | | | | | | |
| | 10 | 5 | FN0.5-5 | | | 5.3 (.209) | 8.0 (.315) | 19.3 (.760) | 7.0 (.276) | | | | | | |
| 22 to 16 (0.25 to 1.65) | 1-2 | 2 | FN1.25-2 | | | 2.2 (.087) | 5.5 (.217) | 15.7 (.618) | 4.0 (.157) | 9.0 (.354) | 4.0 (.157) | 0.8 (.031) | Red | YNT-2216 YA-1 YA-2 YA-4 BCT-0514 | 1,000 |
| | 3-4 | 3 | FN1.25-3 | RBP1.25-3 | | 3.2 (.126) | 5.5 (.217) | 15.7 (.618) | 4.0 (.157) | | | | | | |
| | 3-4 | 3 | FN1.25-MS3 | | | 3.2 (.126) | 5.5 (.217) | 17.4 (.685) | 5.6 (.220) | | | | | | |
| | 3-4 | 3 | FN1.25-L3 | | | 3.2 (.126) | 8.0 (.315) | 20.0 (.787) | 7.0 (.276) | | | | | | |
| | 5-6 | 3.5 | FN1.25-3.7 | | | 3.7 (.146) | 5.5 (.217) | 15.7 (.618) | 4.0 (.157) | | | | | | |
| | 5-6 | 3.5 | FN1.25-M3 | RBP1.25-3.5 | | 3.7 (.146) | 6.6 (.260) | 18.6 (.732) | 6.3 (.248) | | | | | | |
| | 8 | 4 | FN1.25-M4 | | | 4.3 (.169) | 6.6 (.260) | 18.6 (.732) | 6.3 (.248) | | | | | | |
| | 8 | 4 | FN1.25-4 | RBP1.25-4 | | 4.3 (.169) | 8.0 (.315) | 20.0 (.787) | 7.0 (.276) | | | | | | |
| | 10 | 5 | FN1.25-5 | RBP1.25-5 | | 5.3 (.209) | 8.0 (.315) | 20.0 (.787) | 7.0 (.276) | | | | | | |
| | 1/4 | 6 | FN1.25-6 | | | 6.4 (.252) | 11.6 (.457) | 25.9 (1.020) | 11.1 (.437) | | | | | | |
| | 5/16 | 8 | FN1.25-8 | | | 8.4 (.331) | 11.6 (.457) | 25.9 (1.020) | 11.1 (.437) | | | | | | |
| | 3/8 | 10 | FN1.25-10 | | | 10.5 (.413) | 13.6 (.535) | 29.7 (1.169) | 13.9 (.547) | | | | | | |
| | 16 to 14 (1.04 to 2.63) | 1-2 | 2 | FN2-S2 | | | 2.2 (.087) | 6.4 (.252) | 16.5 (.650) | | | | | | 4.3 (.169) |
| 3-4 | | 3 | FN2-MS3 | | | 3.2 (.126) | 5.5 (.217) | 17.4 (.685) | 5.6 (.220) | | | | | | |
| 3-4 | | 3 | FN2-S3.3 | | | 3.2 (.126) | 6.4 (.252) | 16.5 (.650) | 4.3 (.169) | | | | | | |
| 3-4 | | 3 | FN2-3 | | | 3.2 (.126) | 8.5 (.335) | 21.0 (.827) | 7.8 (.307) | | | | | | |
| 5-6 | | 3.5 | FN2-S3 | | | 3.7 (.146) | 6.4 (.252) | 16.5 (.650) | 4.3 (.169) | | | | | | |
| 5-6 | | 3.5 | FN2-M3 | RBP2-3.5 | | 3.7 (.146) | 6.6 (.260) | 18.6 (.732) | 6.3 (.248) | | | | | | |
| 5-6 | | 3.5 | FN2-P3.5 | | | 3.7 (.146) | 7.0 (.276) | 20.2 (.780) | 7.7 (.303) | | | | | | |
| 8 | | 4 | FN2-M4 | | | 4.3 (.169) | 6.6 (.260) | 18.6 (.732) | 6.3 (.248) | | | | | | |
| 8 | | 4 | FN2-P4 | | | 4.3 (.169) | 7.0 (.276) | 20.2 (.800) | 7.7 (.303) | | | | | | |
| 8 | | 4 | FN2-4 | RBP2-4 | | 4.3 (.169) | 8.5 (.335) | 21.0 (.827) | 7.8 (.307) | | | | | | |
| 10 | | 5 | FN2-M5 | | | 5.3 (.209) | 8.5 (.335) | 21.0 (.827) | 7.8 (.307) | | | | | | |
| 10 | | 5 | FN2-5 | RBP2-5 | | 5.3 (.209) | 9.5 (.374) | 21.0 (.827) | 7.3 (.287) | | | | | | |
| 1/4 | | 6 | FN2-6 | RBP2-6 | | 6.4 (.252) | 12.0 (.472) | 26.0 (1.024) | 11.0 (.433) | | | | | | |
| 5/16 | | 8 | FN2-8 | RBP2-8 | | 8.4 (.331) | 12.0 (.472) | 26.0 (1.024) | 11.0 (.433) | | | | | | |
| 3/8 | | 10 | FN2-10 | | | 10.5 (.413) | 13.6 (.535) | 29.7 (1.169) | 13.9 (.547) | | | | | | |
| 1/2 | | 12 | FN2-12 | | | 13.0 (.512) | 19.0 (.748) | 35.2 (1.386) | 16.7 (.657) | | | | | | |
| 1/2 | | 14 | FN2-14 | | | 15.0 (.591) | 27.0 (1.063) | 43.7 (1.720) | 21.2 (.835) | | | | | | |
| 5/8 | | 16 | FN2-16 | | | 17.0 (.669) | 27.0 (1.063) | 43.7 (1.720) | 21.2 (.835) | | | | | | |
| 3/4 | | 20 | FN2-20 | | | 21.0 (.827) | 27.0 (1.063) | 43.7 (1.720) | 21.2 (.835) | | | | | | |
| 12 to 10 (2.63 to 6.64) | | 3-4 | 3 | FN5.5-3 | | | 3.2 (.126) | 9.5 (.374) | 26.5 (1.403) | 8.3 (.327) | 13.5 (.531) | 6.8 (.268) | 1.0 (.039) | Yellow | YNT-1210S YA-4 BCT-0514 |
| | 5-6 | 3.5 | FN5.5-S3 | | | 3.7 (.146) | 7.2 (.283) | 23.0 (.906) | 5.9 (.232) | | | | | | |
| | 8 | 4 | FN5.5-S4 | | | 4.3 (.169) | 7.2 (.283) | 23.0 (.906) | 5.9 (.232) | | | | | | |
| | 8 | 4 | FN5.5-4 | RBP5.5-4 | | 4.3 (.169) | 9.5 (.374) | 26.5 (1.043) | 8.3 (.327) | | | | | | |
| | 10 | 5 | FN5.5-5 | RBP5.5-5 | | 5.3 (.209) | 9.5 (.374) | 26.5 (1.043) | 8.3 (.327) | | | | | | |
| | 10 | 5 | FN5.5-S5 | | | 5.3 (.209) | 13.2 (.520) | 29.1 (1.146) | 9.0 (.354) | | | | | | |
| | 1/4 | 6 | FN5.5-6 | RBP5.5-6 | | 6.4 (.252) | 12.0 (.472) | 32.5 (1.280) | 13.0 (.512) | | | | | | |
| | 1/4 | 6 | FN5.5-S6 | | | 6.4 (.252) | 13.2 (.520) | 29.1 (1.146) | 9.0 (.354) | | | | | | |
| | 5/16 | 8 | FN5.5-S8 | | | 8.4 (.331) | 13.2 (.520) | 29.1 (1.146) | 9.0 (.354) | | | | | | |
| | 5/16 | 8 | FN5.5-8 | RBP5.5-8 | | 8.4 (.331) | 15.0 (.591) | 34.7 (1.366) | 13.7 (.539) | | | | | | |
| | 3/8 | 10 | FN5.5-10 | RBP5.5-10 | | 10.5 (.413) | 15.0 (.591) | 34.7 (1.366) | 13.7 (.539) | | | | | | |
| | 1/2 | 12 | FN5.5-12 | | | 13.0 (.512) | 19.2 (.756) | 39.1 (1.539) | 16.0 (.630) | | | | | | |
| | 1/2 | 14 | FN5.5-14 | | | 15.0 (.591) | 32.0 (1.260) | 54.8 (2.157) | 25.3 (.996) | | | | | | |
| | 5/8 | 16 | FN5.5-16 | | | 17.0 (.669) | 32.0 (1.260) | 54.8 (2.157) | 25.3 (.996) | | | | | | |
| | 11/16 | 18 | FN5.5-18 | | | 19.0 (.748) | 32.0 (1.260) | 54.8 (2.157) | 25.3 (.996) | | | | | | |
| | 3/4 | 20 | FN5.5-20 | | | 21.0 (.827) | 32.0 (1.260) | 54.8 (2.157) | 25.3 (.996) | | | | | | |

- Note: 1) Products with the JIS mark conform to JIS C2805.
 2) *The crimping will be more secure if the total cross-sectional area of the wire is at least 0.5 mm².
 Examples: If the cross-sectional area of the wire is 0.3mm², fold the wire in two when crimping the terminal.
 If the cross-sectional area of the wire is 0.5mm², crimp the terminal onto the wire as it is.
 3) Because nylon absorbs moisture, care must be taken concerning storage.
 4) The part numbers indicated in the above table are for products with a brazed seam,
 When ordering products with a butted seam, add the prefix "WS" to the part number (ex. FN2-4 → **FNWS2-4**).
 5) Delivery lead times may vary depending on the product. Contact JST for details.