

# CMKS-L DIES CONSTRUCTION SHEET

# JST

Terminal/Contact Model No.	SXH-001T-P0.6	Die set Model No.	SXH-001-06
		Applicator Model No.	CMKS-L
		Crimp shape (wire)	N-1.5
		Crimp shape (ins)	N-1.8
Clearance between Crimper (B) and Shear blade			0.1
Description	No.	Description	No.
Crimper (A)	63510	Crimper anvil (A)	C75720
Crimper (B)	64440	Crimper anvil (B)	C76580
Spacer (A)	65080		
Spacer (B)			
Spacer (C)			
Punch	68225	Spacer	C77190
Die holder	67680	Shear blade	C74370
Spring		Shear blade supporter	C73120
Wire block	A325	Shear blade base	C78010
Insulation block	B262	Shear blade spring	C87010
Wire hold punch	68235	Feed finger	G6190
Wire hold punch spring	87270	Feed finger holder	G6141
Guide plate (L)	C81270	Stripper	91320
Guide plate (R)	C82163	Stripper bracket	92230
Feed plate	C84230	Stripper pin	
Pressure plate	C83061		
Pressure spring(2pcs)	87001	Scrap cover	C95310
Wire and Crimp height		Remarks	
Wire		Crimp height (mm)	
Type	Size	Wire	Ins
UL1007	#28	0.60~0.65	2
UL1007	#26	0.65±0.05	2
UL1007	#24	0.70±0.05	2.1
UL1007	#22	0.75±0.05	2.2
Prepared by		K. Fujii	Issue date
			Oct 01, 1996



Side-Feeding Applicator  
CMKS-L  
Die Set Assembly

Applicable  
terminal/  
contact

SXH-001-06

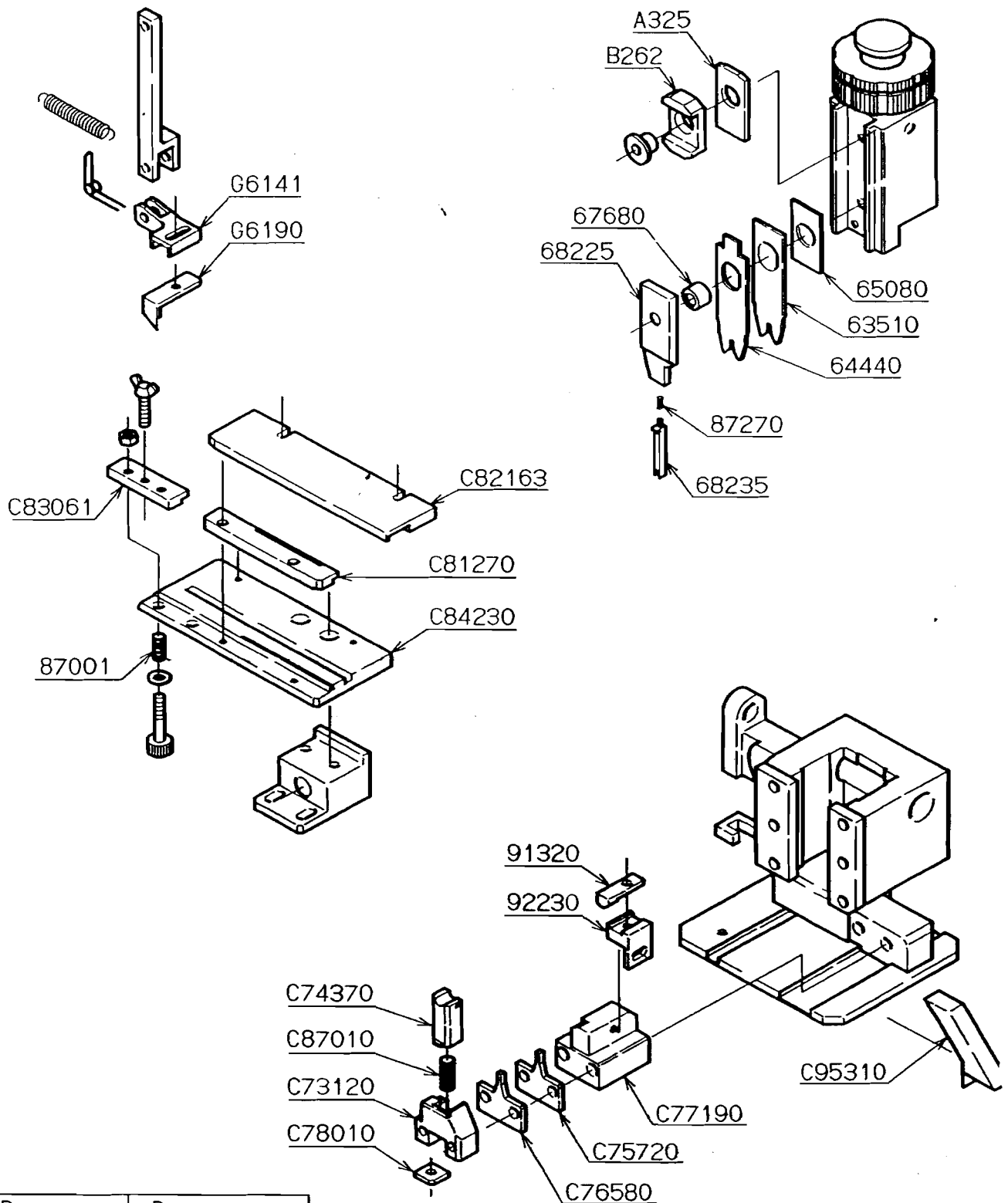

Date	Drawn by
MAY 4 07	Y. OKADA