

Features

- High Efficiency (Up to 90%)
- Second Generation with Improved Performance
- Active Power Factor Correction (Typical 0.95)
- Constant Output Current
- Lightning Protection
- Waterproof (IP67)
- Dimming Control
- All-Round Protection: OVP, SCP, OLP, OTP
- Comply With UL8750 & EN61347 Safety Regulations



Description

The EUC-036SxxxDT/ST series operate from a 90 ~ 305 Vac input range. These units will provide up to a 1750 mA of output current and a maximum output voltage of 103 V for 36 W maximum output power. They are designed to be highly efficient and highly reliable. Features include Dimming control, over voltage protection, short circuit protection and over load protection.

Models

Output Current	Input Voltage	Output Voltage Range	Max. Output Power	Typical Efficiency (1)	Power Factor		Model Number (2, 3)
					110Vac	220Vac	
350 mA	90 ~ 305 Vac	52-103 Vdc	36 W	90%	0.98	0.95	EUC-036S035DT/ST (4)
450 mA	90 ~ 305 Vac	40-80 Vdc	36 W	89%	0.98	0.95	EUC-036S045DT/ST (4)
700 mA	90 ~ 305 Vac	26-52 Vdc	36 W	88%	0.98	0.95	EUC-036S070DT/ST (5)
1050 mA	90 ~ 305 Vac	18-35 Vdc	36 W	88%	0.98	0.95	EUC-036S105DT/ST (6)
1400 mA	90 ~ 305 Vac	13-26 Vdc	36 W	87%	0.98	0.95	EUC-036S140DT/ST (6)
1750 mA	90 ~ 305 Vac	11-21 Vdc	36 W	86%	0.98	0.95	EUC-036S175DT/ST (6)

Notes: (1) Measured at full load and 220 Vac input.

(2) The DT suffix may be changed to ST to omit the dimming function and remove the three wires associated with that function.

(3) A suffix -xxxx may be added to denote variations or modifications to the base product, where x can be any alphanumeric character or blank.

(4) Non-Class 2 output (USR & CNR).

(5) Class 2 output (USR), Non-Class 2 output (CNR).

(6) Class 2 output (USR & CNR).

Input Specifications

Parameter	Min.	Typ.	Max.	Notes
Input Voltage	90 V	-	305 V	
Input Frequency	47 Hz	-	63 Hz	
Leakage Current	-	-	0.75 mA	At 277Vac 50Hz input
Input AC Current	-	-	0.6 A	Measured at full load and 100 Vac input.
	-	-	0.3 A	Measured at full load and 220 Vac input.
Inrush Current	-	-	60 A	At 230Vac input 25°C Cold Start. Duration=100µs

Specifications are subject to changes without notice.

Output Specifications

Parameter	Min.	Typ.	Max.	Notes
Output Current Tolerance	-5% I _O	-	5% I _O	
No load output voltage				
I _O = 350 mA	-	-	113V	
I _O = 450 mA	-	-	90 V	
I _O = 700 mA	-	-	60 V	
I _O = 1050 mA	-	-	42 V	
I _O = 1400 mA	-	-	32 V	
I _O = 1750 mA	-	-	28 V	
Output Current Ripple	-		-50% I _O	
Overshoot/Output Current	-	-	10% I _O	
Line Regulation	-	-	1%	
Load Regulation	-	-	3%	
Turn-on Delay Time	-	0.6 s	1.0 s	Measured at 110Vac input.
	-	0.3 s	0.5 s	Measured at 220Vac input.

Note: All specifications are typical at 25 °C unless otherwise stated.

Protection Functions

Parameter	Min.	Typ.	Max.	Notes
Short Circuit Protection	No damage shall occur when any output operating in a short circuit condition. The power supply shall be self-recovery when the fault condition is removed.			
Over Temperature Protection	Hiccup mode. When the case temperature is higher than 110±15°C, the power supply will turn off automatically; when the case temperature is lower than 110±15°C, the power supply will start again.			

General Specifications

Parameter	Min.	Typ.	Max.	Notes	
Efficiency	I _O = 350 mA	88%	89%	-	Measured at full load and 110 Vac input.
	I _O = 450 mA	87%	88%	-	
	I _O = 700 mA	86%	87%	-	
	I _O = 1050 mA	86%	87%	-	
	I _O = 1400 mA	85%	86%	-	
Efficiency	I _O = 350 mA	89%	90%	-	Measured at full load and 220 Vac input.
	I _O = 450 mA	88%	89%	-	
	I _O = 700 mA	87%	88%	-	
	I _O = 1050 mA	87%	88%	-	
	I _O = 1400 mA	86%	87%	-	
No Load Power Dissipation			6 W		

Specifications are subject to changes without notice.

General Specifications (Continued)

Parameter	Min.	Typ.	Max.	Notes
MTBF	469,000 Hours			For 1750 mA output model, measured at 110Vac input, 80%Load and 25°C ambient temperature (MIL-HDBK-217F)
Life Time	74,000 Hours			For 1750 mA output model, measured at 110Vac input and 55°C Case Temperature
Dimensions Inches (L × W × H) Millimeters (L × W × H)	6.77 × 1.36 × 1.67 172 × 34.5 × 42.5			
Net Weight	-	480 g	-	

Note: All specifications are typical at 25 °C unless otherwise stated.

Environmental Specifications

Parameter	Min.	Typ.	Max.	Notes
Operating Temperature	-35 °C	-	+70 °C	Humidity: 10% RH to 100% RH.
Storage Temperature	-40 °C	-	+85 °C	Humidity: 5% RH to 100% RH

Safety & EMC Compliance

Safety Category	Standard
UL/CUL	UL8750, UL935, UL1012, UL1310 Class 2, CSA-C22.2 No. 107.1, CSA C22.2 NO. 223-M91 Class 2
CE	EN 61347-1, EN61347-2-13
EMI Standards	Notes
EN 55015	Conducted emission Test & Radiated emission Test with 6 dB margin
EMS Standards	Notes
EN 61000-3-2	Harmonic Current Emissions
EN 61000-3-3	Voltage Fluctuations & Flicker
EN 61000-4-2	Electrostatic Discharge (ESD): 8 kV air discharge, 4 kV contact discharge
EN 61000-4-3	Radio-Frequency Electromagnetic Field Susceptibility Test-RS
EN 61000-4-4	Electrical Fast Transient / Burst-EFT: level 3, criteria A
EN 61000-4-5	Surge Immunity Test: AC Power Line: line to line 4 kV, line to earth 6 kV
EN 61000-4-6	Conducted Radio Frequency Disturbances Test-CS
EN 61000-4-8	Power Frequency Magnetic Field Test
EN 61000-4-11	Voltage Dips
EN 61547	Electromagnetic Immunity Requirements Applies To Lighting Equipment

Specifications are subject to changes without notice.

Derating Curve

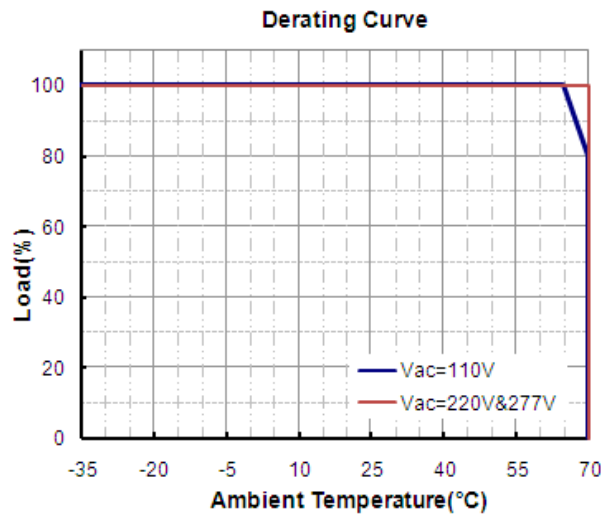

Life Time

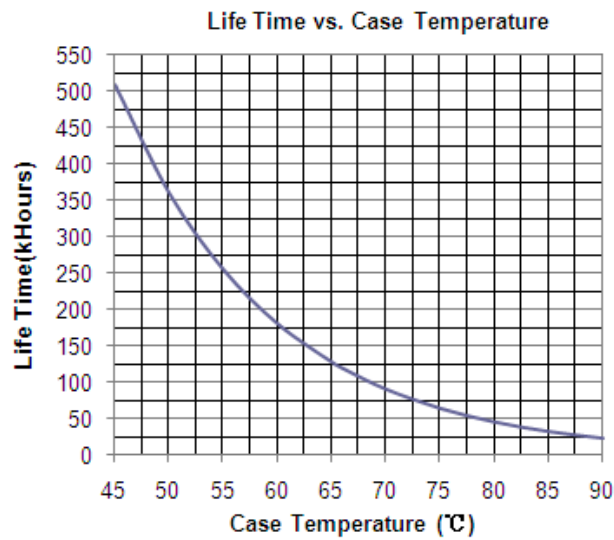

Power Factor Characteristics

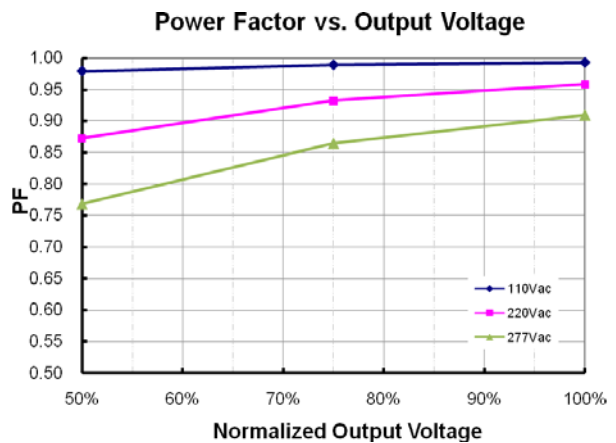
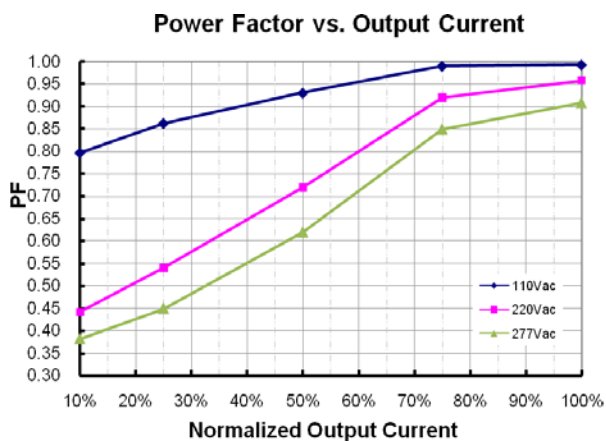

Specifications are subject to changes without notice.

Efficiency vs. Load (350mA Model)

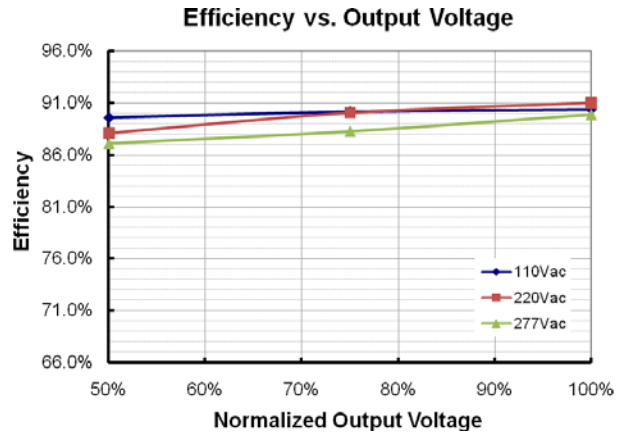
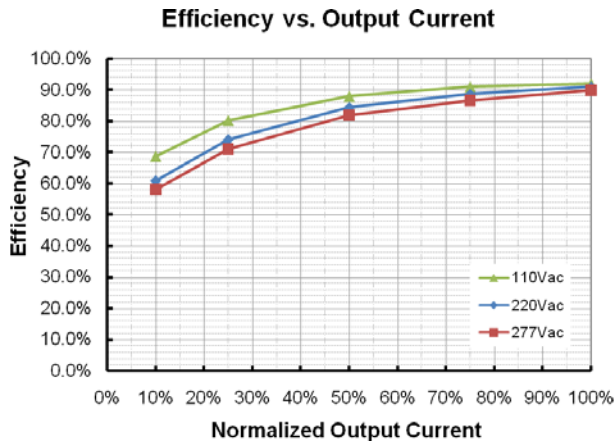

Dimming Control (On Secondary Side)

Parameter	Min.	Typ.	Max.	Notes
12V Output Voltage	10.8 V	12 V	13.2 V	
12V Output Source Current	0 mA	-	20 mA	
Absolute Maximum Voltage on the 0~10V Input Pin	-2 V	-	15 V	
Source Current on 0~10V Input Pin	0 uA	-	200 uA	

The dimmer control may be operated from either a dimmer or from an input signal of 0 – 10 Vdc. The recommended implementation is provided below.

Notes:

Do not connect the GND of dimming to the output, otherwise, the LED driver can not work normally.

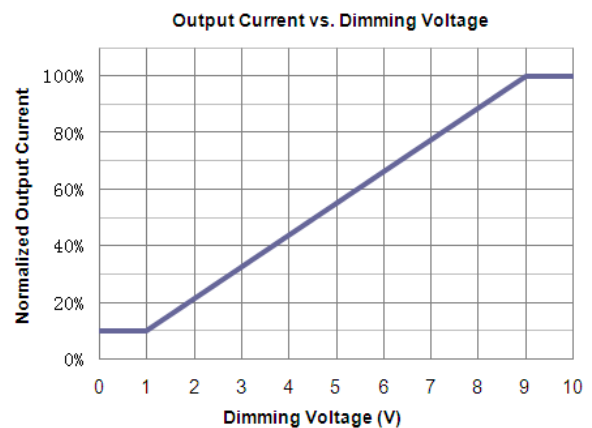
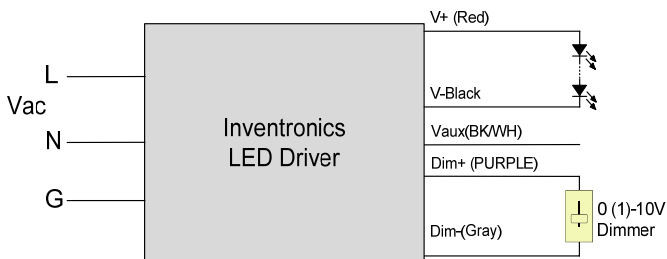

Mechanical Outline

EUC-036SxxxST

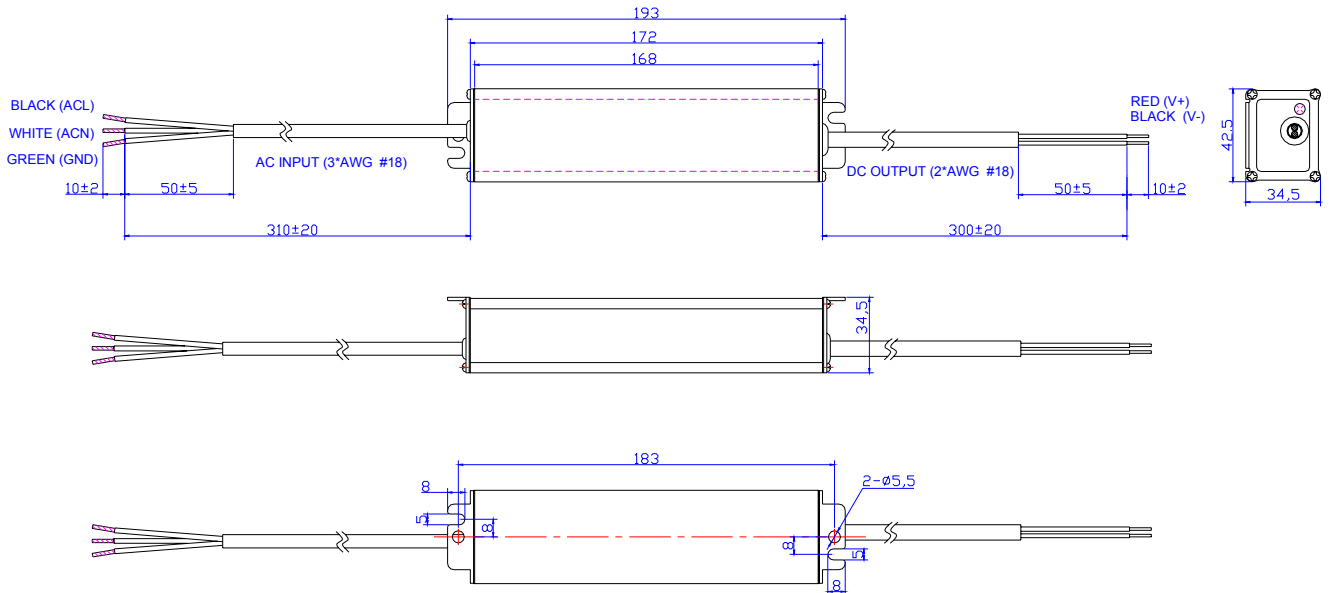

EUC-036SxxxDT

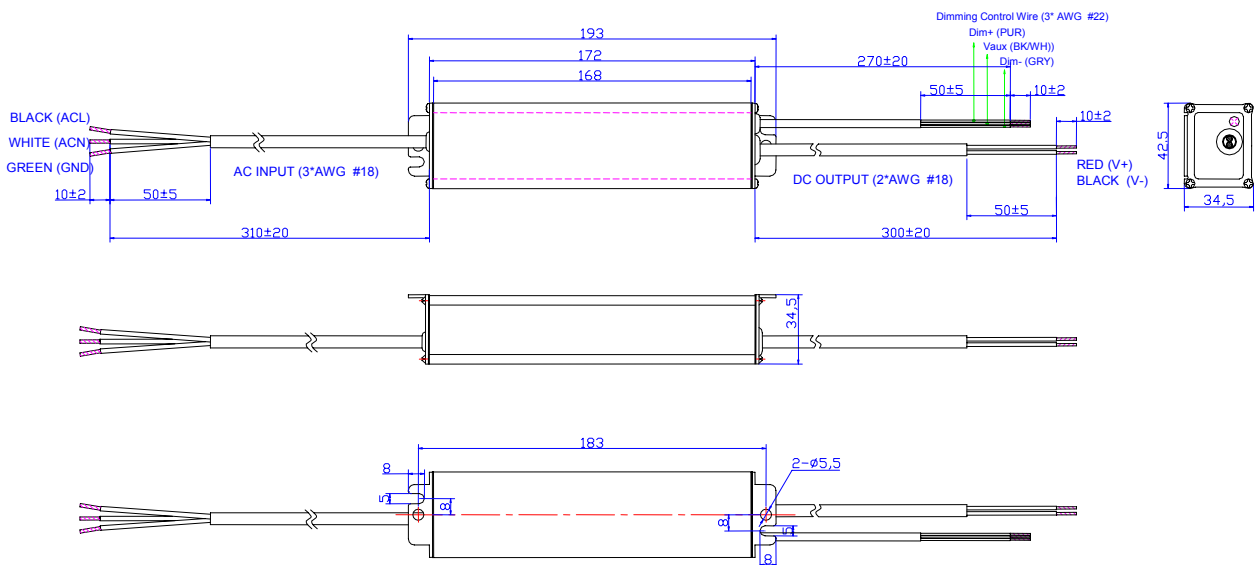

RoHS Compliance

Our products comply with the European Directive 2002/95/EC, calling for the elimination of lead and other hazardous substances from electronic products.

Revision History

Change Date	Rev.	Description of Change		
		Item	From	To
2010-04-07	V1.0	First Release	/	/
2010-10-20	V2.0	Update the part of dimming control	/	/
2011-7-20	V4.0	Input Specifications-Input AC Current	0.49,0.25	0.6,0.3
		Output Specifications-Turn-on Delay Time	0.3,0.2,0.5,0.3	0.6,0.3,1.0,0.5
		MTBF	/	469,000
		Life Time	/	74,000
		Operating Temperature	+55	+70
		Life Time Curve; PF Curve; Efficiency Curve;	/	Added
		Derating Curve	/	Add 277V,220V Curve
2011-7-28	V4.1	Power Factor:110 Vac	0.99	0.98
2011-12-2	V4.3	OTP	/	Added