

P2 Series

Single- and dual-core communications processors

Freescale QorIQ™ communications platforms are the next-generation evolution of our leading PowerQUICC® communications processors. Built using high-performance Power Architecture® cores, Freescale QorIQ platforms enable a new era of networking innovation where the reliability, security and quality of service for every connection matters.

QorIQ P2020 and P2010 Communications Processors

The QorIQ P2 platform series, which includes the P2020 and P2010 communications processors, delivers unprecedented performance per watt for a wide variety of applications in the networking, telecom, military and industrial markets. The series delivers dual- and single-core frequencies up to 1.2 GHz on a 45 nm technology low-power platform.

The QorIQ P2 series consists of dual- and single-core products that are pin-compatible

with the QorIQ P1 platform products, offering five interchangeable cost-effective solutions. Scaling from a single core at 400 MHz (P1010) to a dual core at 1.2 GHz (P2020), the two QorIQ platforms together deliver an impressive 6x aggregate frequency range within the same pinout.

The devices in these two series are software-compatible, sharing the e500 Power Architecture core and peripherals, as well as being fully software compatible with the existing PowerQUICC processors. This enables you to create a product with multiple performance points from a single board design. The P2020 and P1020 processors support symmetric and asymmetric multi-processing, enabling you to scale performance through either thread-level or application-level parallelism.

The P2020 and P2010 communications processors both have an advanced set of

features for ease of use. The integrated security engine supports common security algorithms used in networking and wireless applications, such as IPSec and Kasumi. The 64-bit memory controller offers future-proofing against memory technology migration with support for both DDR2 and DDR3. It also supports error correction codes, a baseline requirement for any high-reliability system. Other memory types such as flash are supported through the 16-bit local bus, USB, SD/MMC and SPI.

The QorIQ P2 series integrates a rich set of interfaces including SerDes, Gigabit Ethernet, PCI Express®, RapidIO® technology and USB. The three 10/100/1000 Ethernet ports support advanced packet parsing, flow control and quality of service features, as well as IEEE® 1588 time-stamping. Four SerDes lanes can be portioned across two Serial RapidIO ports, three PCI Express ports and two SGMII ports.

QorIQ™ P2020 and P2010 Block Diagram

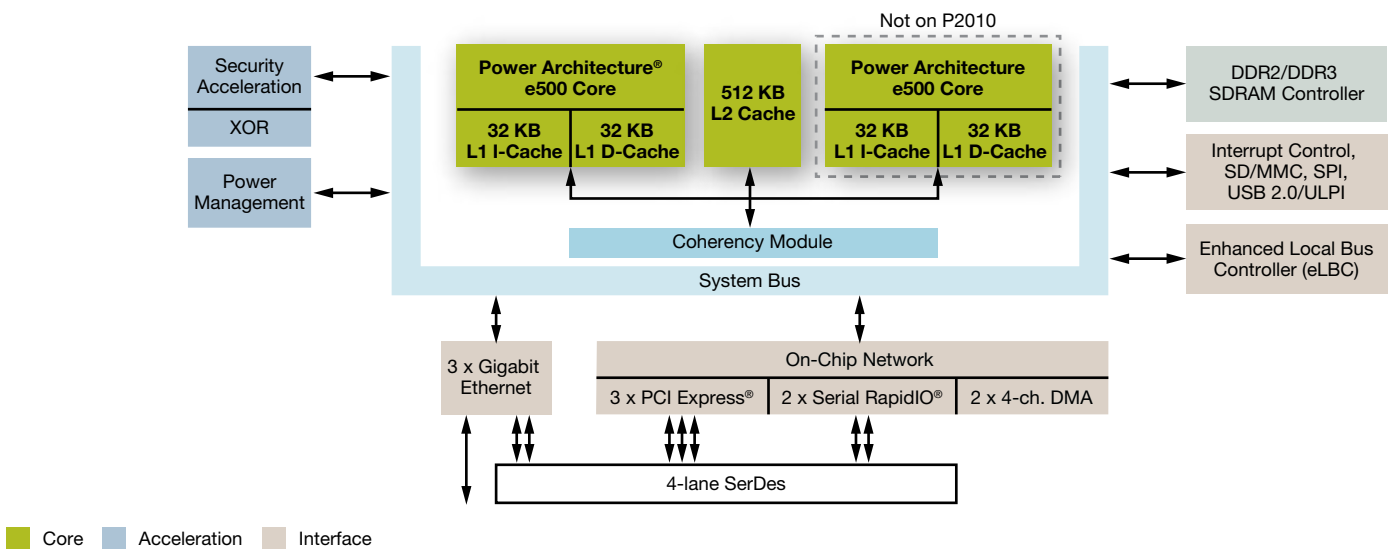

Target Applications

The QorIQ P2 platform products serve in a wide range of applications, especially those that have tight thermal constraints. The products enable various combinations of data plane and control plane workloads in networking and telecom applications. With an available junction temperature range of -40°C to 125°C, they can also be used in power-sensitive military and industrial applications, and less-protected outdoor environments. The devices' primary target applications are networking and telecom linecards.

The networking linecard requires an optimal combination of good performance to manage a large amount of control plane traffic balanced against low power and cost. With convenient I/O, flexible core configurations and an on-board security block, the P2010 and P2020 processors are well-suited for this application, which involves controlling ASICs, managing exceptions and routing table maintenance.

The P2010 and P2020 processors are also well-suited for Long Term Evolution (LTE) and WiMAX channel card applications. With dual-core performance in single-core power budgets, the P2 series facilitates the “flattening” of the wireless network hierarchy. The dual Serial RapidIO interfaces allow direct connection to the DSPs (such as Freescale’s MSC8144 DSP) that implement Layer 1 processing as well as redundant backplane connections.

Technical Specifications

- Dual (P2020) or single (P2010) high-performance Power Architecture e500 cores
 - 36-bit physical addressing
 - Double-precision floating-point support
 - 32 KB L1 instruction cache and 32 KB L1 data cache for each core
 - 800 MHz to 1.2 GHz clock frequency
- 512 KB L2 cache with ECC. Also configurable as SRAM and stashing memory.
- Three 10/100/1000 Mbps enhanced three-speed Ethernet controllers (eTSECs)
 - TCP/IP acceleration and classification capabilities
 - IEEE® 1588 support
 - Lossless flow control
 - R/G/MII, R/TBI, SGMII
 - FIFO interfaces
- High-speed interfaces supporting various multiplexing options
 - Four SerDes to 3.125 GHz multiplexed across controllers
 - Three PCI Express interfaces
 - Two Serial RapidIO interfaces
 - Two SGMII interfaces
- High-Speed USB controller (USB 2.0)
 - Host and device support
 - Enhanced host controller interface (EHCI)
 - ULPI interface to PHY
- Enhanced secure digital host controller (SD/MMC)
- Serial peripheral interface
- Integrated security engine
 - Protocol support includes SNOW, ARC4, 3DES, AES, RSA/ECC, RNG, single-pass SSL/TLS, Kasumi
 - XOR acceleration
- 64-bit DDR2/DDR3 SDRAM memory controller with ECC support
- Programmable interrupt controller (PIC) compliant with OpenPIC standard
- Two four-channel DMA controllers
- Two I²C controllers, DUART, timers
- Enhanced local bus controller (eLBC)
- 16 general-purpose I/O signals
- Package: 689-pin wirebond power-BGA (TEPBGA2)

QorIQ™ Platform	Device	Cores	Top Core Frequency	L2 Size	DDR 2/3 Support	GE Ports	SerDes	PCI Express®	Serial RapidIO®	TDM
P1	P1010	1	667 MHz	N/A	32-bit with ECC	2	2	2	N/A	N/A
P1	P1011	1	800 MHz	256 KB	32-bit with ECC	3	4	2	N/A	Yes
P1	P1020	2	800 MHz	256 KB	32-bit with ECC	3	4	2	N/A	Yes
P2	P2010	1	1200 MHz	512 KB	64-bit with ECC	3	4	3	2	N/A
P2	P2020	2	1200 MHz	512 KB	64-bit with ECC	3	4	3	2	N/A

Learn More:

For current information about Freescale products and documentation, please visit www.freescale.com/multicore.



Freescale, QorIQ, CoreNet and the Freescale logo are trademarks or registered trademarks of Freescale Semiconductor, Inc. in the U.S. and other countries. All other product or service names are the property of their respective owners. The Power Architecture and Power.org word marks and the Power and Power.org logos and related marks are trademarks and service marks licensed by Power.org. © Freescale Semiconductor, Inc. 2008.

Document Number: QP20XXFS
REV 0

