



F360L-3C-S Side-Emitter Lens for CREE™ XP-E and XP-G LEDs

- High efficiency
- High-temperature material
- Easy assembly

The F360L-3C-S lens is specifically designed for the Cree Corporation ⁽¹⁾ CREE® XP-series LEDs.

A software-optimized profile provides a 360-degree pattern with high collection efficiency reaching 85% of the total flux emitted from the LED.

The lens flange can be glued to the PCB to provide a secure assembly.

Typical applications are:

360-degree illumination devices, such as:

- Beacons
- Navigation lights
- Warning lights
- Electronic flares

Reflector-based systems requiring excellent light control and/or minimal direct light, such as:

- Streetlights
- Flashlights/torches
- Task lights
- Channel-letter signs
- Spot-lights



- (1) CREE® XP-E and XP-G are trademarks of Cree, Inc. For technical specification on LEDs please refer to the CREE® XLamp datasheet or visit www.cree.com/products
- (2) Typical beam divergence may change with different color LEDs.

FRAEN Corporation OMG
80 Newcrossing Road
Reading MA 01867
USA
Phone: +1 781.205.5300
Fax: +1 781.942.2426

FRAEN Corporation Srl
Via delle Querce, 22
27020 Trivulzio (PV)
Italy
Phone: +39 0382 1933.1
Fax: +39 0382 1933.239

Inquiries: optics@fraen.com
Website: www.fraenomg.com

For ordering information, please contact:

NAFTA Countries	ARROW Telephone: 1-888-9LIGHT1 email: lightingsolutions@arrow.com
European Countries	Please contact Fraen S.r.l. for distributor's information Email: optics@fraen.com



General Characteristics

Lens Material	Polycarbonate, UL94 V2 rated
Operating Temperature range	-40°C / + 128°C
Storage Temperature range	-40°C / + 128° C

Average transmittance in visible spectrum (400 – 700nm) >85%

Please note that flow lines and weld lines on the external surfaces of the lenses are acceptable if the optical performance of the lens is within the specification described in the section "OPTICAL CHARACTERISTICS"

IMPORTANT NOTE – Lenses handling and cleaning:

- *Handling: Always use gloves to handle lenses and/or handle the lenses only by the flange. Never touch the optical surfaces of the lenses with fingers; finger oils and contamination will absorb or refract light.*
- *Cleaning: Clean lenses only if necessary. Use only soap and water to clean the surfaces. Never expose the lenses to alcohol, as it will damage the plastic.*

Scope

This datasheet provides information about the F360L-3C-S lens for CREE XP-E and XP-G LEDs.

Optical Characteristics

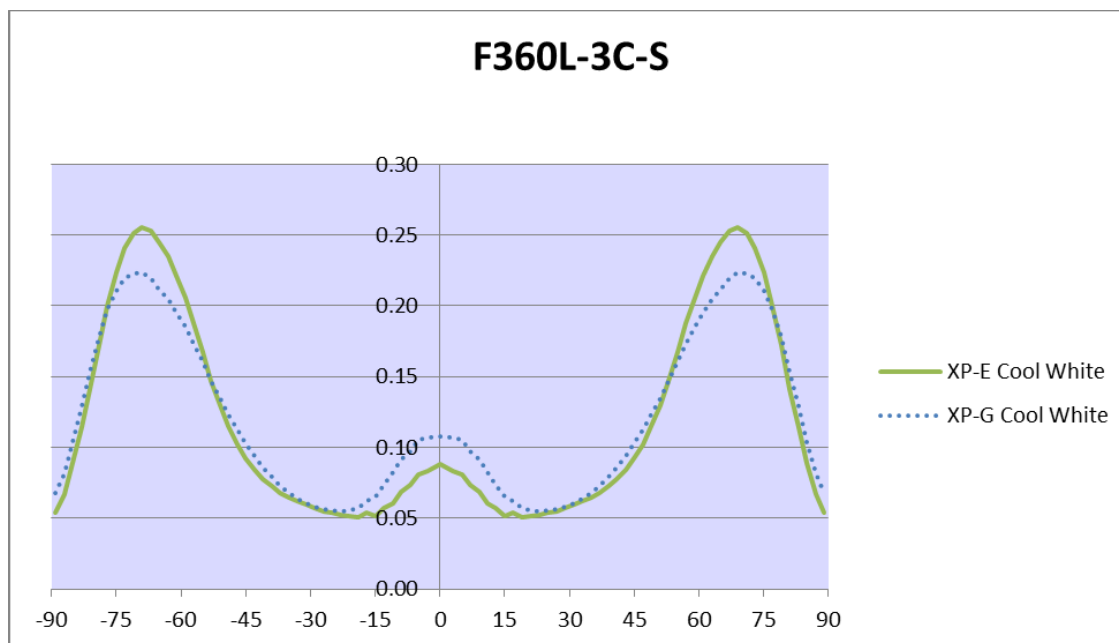

	XP-E Cool White		XP-G Cool White	
	Candela/Lumen	Angle (degrees)	Candela/Lumen	Angle (degrees)
Peak Intensity	0.26	±69°	0.26	±69°
½-Peak Intensity	0.13	±51° and ±82°	0.13	±51° and ±82°

Figure 1. Spatial Radiation Pattern (candela/lumen vs. angle from axis), with summary table

- (1) To calculate the intensity (candela) at a specific angle, read the candela/lumen value from Figure 1, and multiply this value by the total flux of the CREE XP-series LED used. See "Illumination Calculations" below. For more detail on flux binning please check the CREE LED datasheet at <http://www.cree.com/>
- (2) Luminous intensity depends on the flux binning and tolerances of the LEDs. Please refer to the CREE datasheet for more details on flux binning and mechanical tolerances.



Illumination Calculations

To calculate the intensity (candela) at a specific angle, read the candela/lumen value from the graph in Figure 1, and multiply this value by the total flux of the CREE XP-E LED used. Refer to the CREE XP-E LED datasheet for nominal lumens values. For a more accurate calculation, refer to the intensity “ranking” (binning) tables on the datasheet for the specific LED.

Example calculations:

If the Fraen F360L-3C-S is used on a cool white CREE XP-E LED at 350 mA, the typical luminous flux of the LED is 100 lumens.

The calculation is: $(0.26 \text{ candela/lumen}) \times (100 \text{ lumens}) = 26 \text{ candela}$, at $\pm 69^\circ$ off-axis. At $\pm 51^\circ$ and $\pm 82^\circ$ off-axis, the intensity is $\frac{1}{2}$ of the peak. This means at $\pm 51^\circ$ and $\pm 82^\circ$ off-axis, the intensity should be $\frac{1}{2}$ of 26 candela, or 13 candela.

1 candela at 1-meter distance produces 1 Lux. This means the peak intensity at 1 meter will be 26 lux. The intensity decreases as a function of the distance squared, so at 2 meters the peak intensity will be $26 / (2^2) = 6.5 \text{ lux}$. At 3 meters distance, the peak intensity will be $26 / (3^2) = 3.2 \text{ lux}$.

Mechanical Characteristics

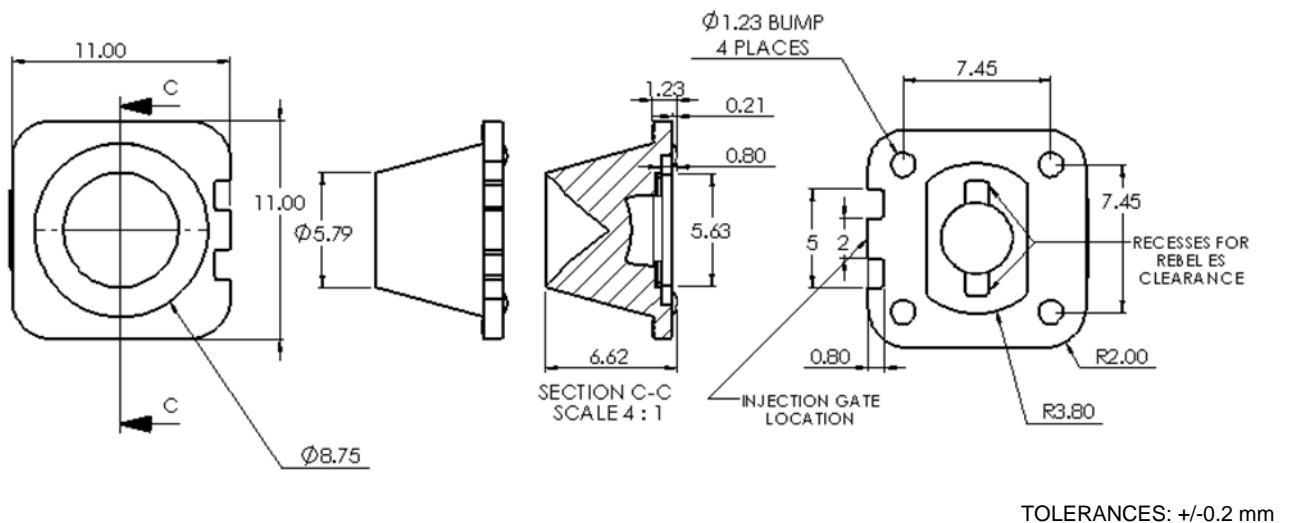

Figure 2. Dimensions of the F360L-3C-S lens

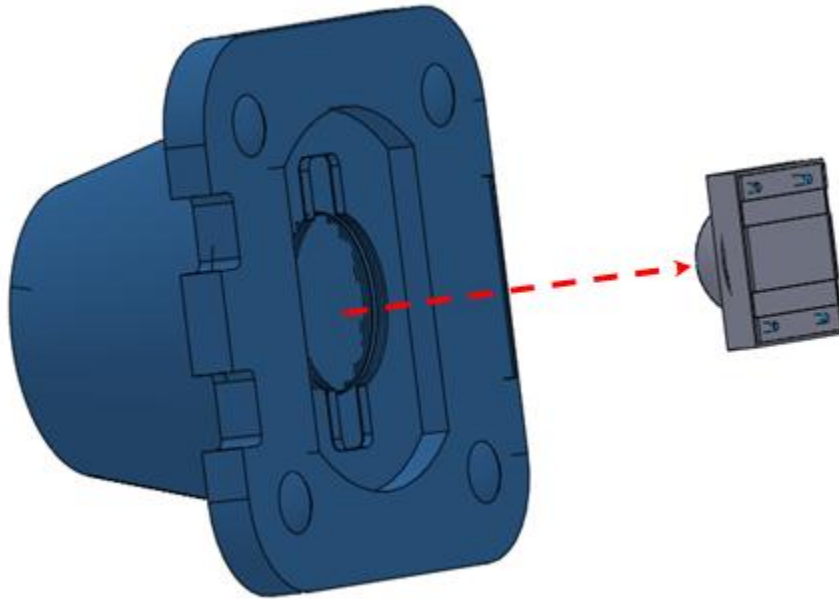

Figure 3. The center of the F360L-3C-S lens should be aligned with the center of the LED dome lens. There is sufficient clearance in the bottom of the F360L-3C-S lens to accept the square LED package.

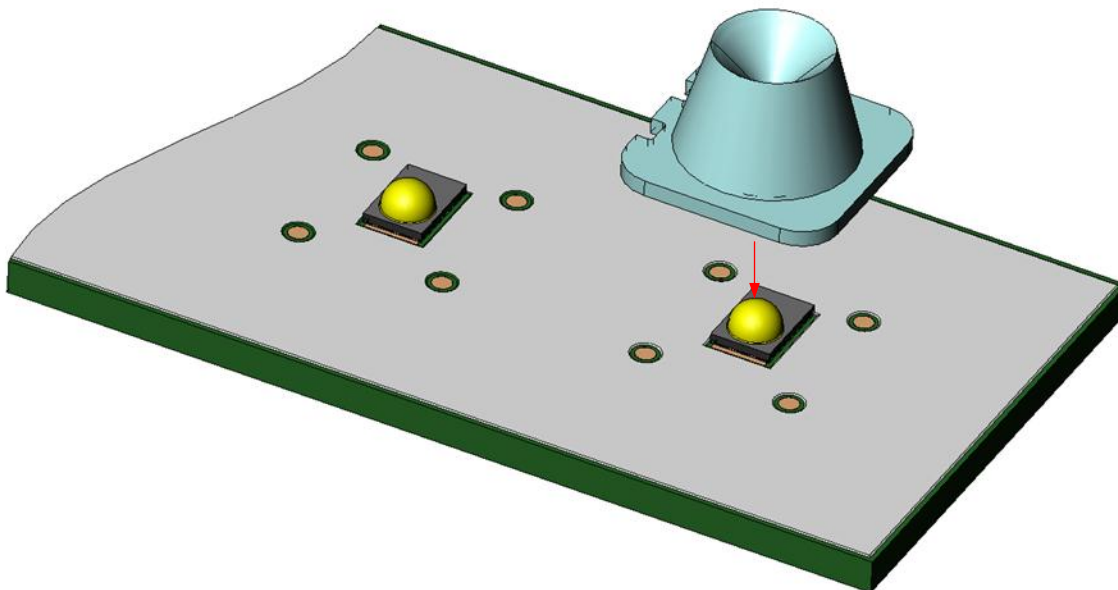

Figure 4. The square flange of the F360L-3C-S lens has 4 bumps, which should fit into 4 recesses in the PCB solder-mask.

See *Figures 2 and 7* for locating pin layout and dimensions.

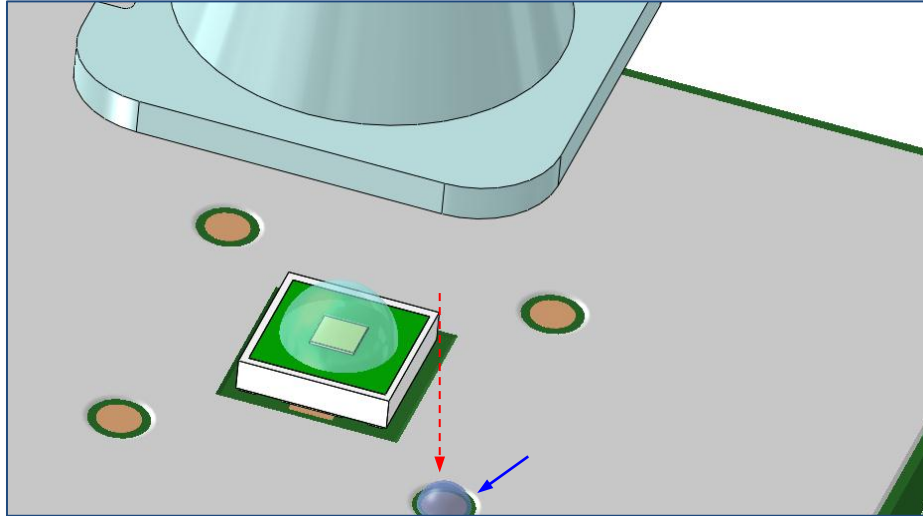

Figure 5. A small droplet of glue is placed at each of the 4 solder-mask hole locations, to bond the four lens “bumps” to the PCB. A fixture or automated placement machine will be required to assure proper lens location (to center the lens to the LED die).

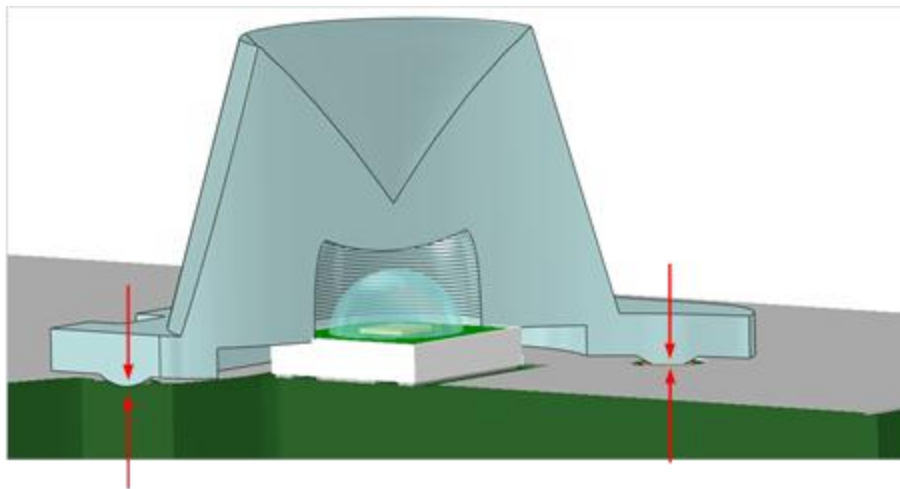

Figure 6. The correct height is achieved when the lens bumps touch the PCB copper (same plane as LED solder).

DESIGN NOTE: Proper lens to LED alignment requires that the PCB have recesses to accommodate the locating pins on the lens

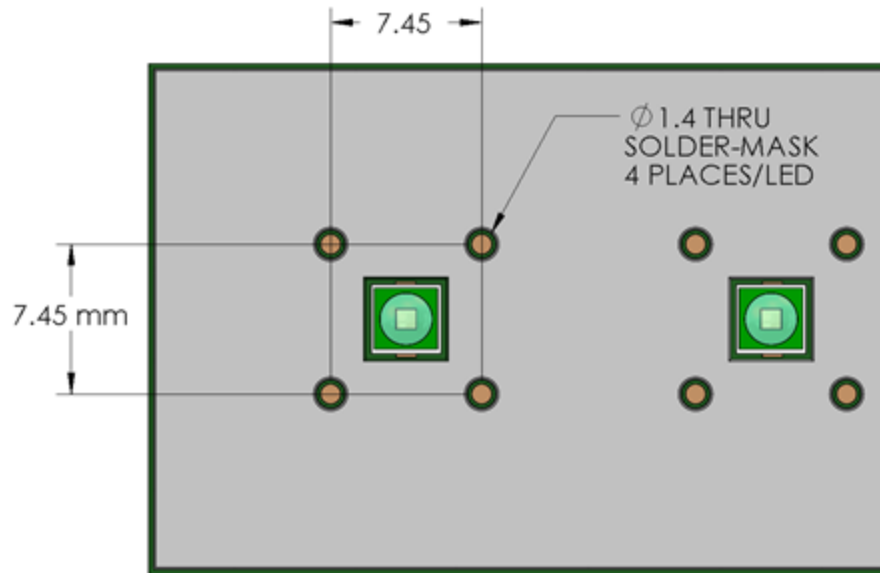

Figure 7. Dimensions and layout of the PCB location recesses used to align the lens to the LED. (All dimensions in millimeters)

Packaging Information – Tape & Reel

The F360L-3C-S lens is available only in Tape & Reel packaging.

Reel capacity: 515 lens in pockets with a ten pocket (empty) leader and a five pocket trailer.

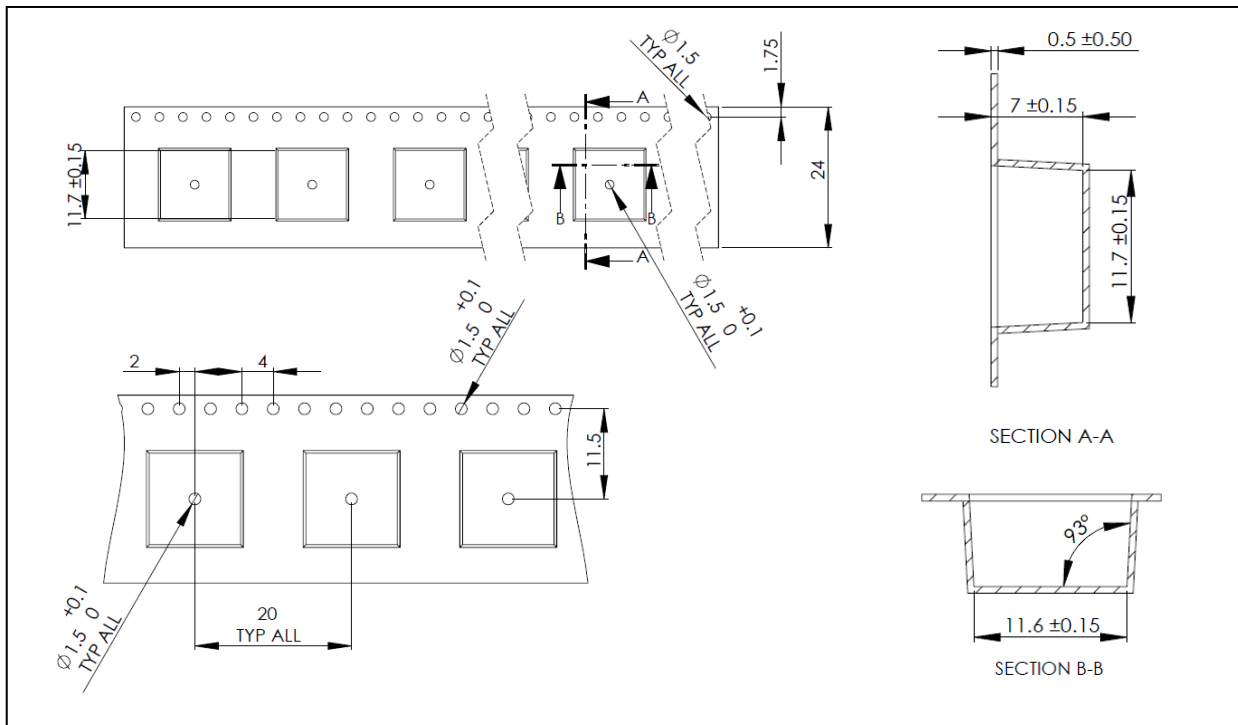

Figure 8: Tape dimensions and layout
(All dimensions in millimeters)

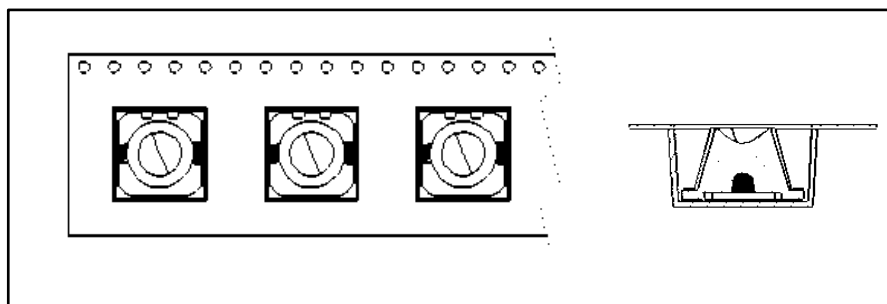

Figure 9: Orientation of lens in tape pockets

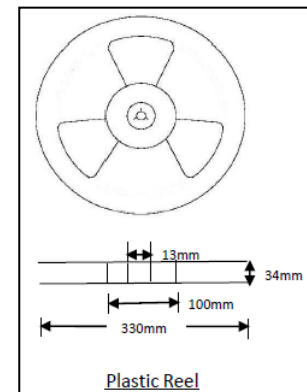

Fig. 10: Reel Dimensions



Ordering part number

F360L-3C-S

(for both the Cree XP-E and XP-G LEDs)

Published by Fraen Corporation.

All data contained in this document is the property of Fraen Corporation and may change without notice.