

REV.	ECON. NO.	APPD.
X7		

NOTE: UNLESS OTHERWISE SPECIFIED.

1. ALL DIMENSIONS SHALL BE INTERPRETED PER ASME Y14.5M-1994.
2. DIMENSIONS MARKED ∇ SHALL BE CHECKED.
3. HARMFUL MATERIAL CONTROL PLEASE FOLLOW DOC. No.:EP112.
4. THE MANUFACTURE PROCESS MUST BE LEAD-FREE.
5. MECHANICAL CHARACTERISTICS:
 - 5-1. CRIMPING PULL OUT FORCE: 1.4Kgf Min. FOR 26AWG.
 - 5-2. TERMINAL/HOUSING RETENTION FORCE: 1.0Kgf Min(FOR P1).

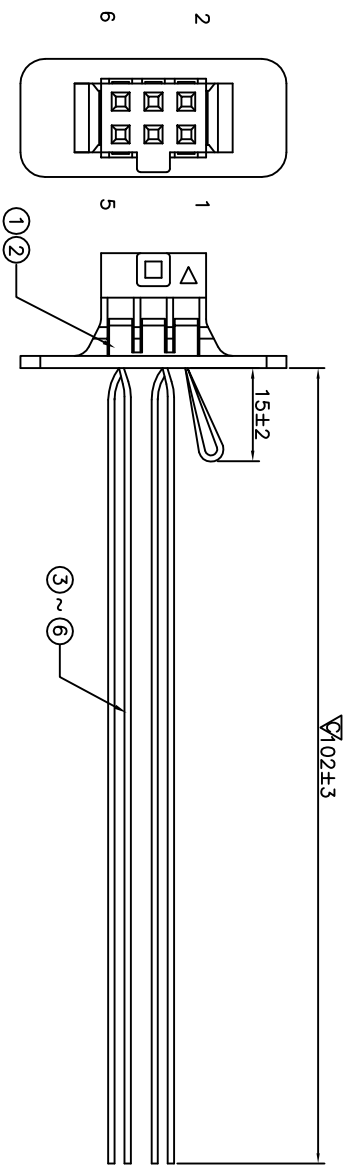

WIRING DIAGRAM			CUTTING LENGTH
P1	P1	RED	A/R
6		BLACK	
5		BROWN	
4		YELLOW	
3		BLACK	
1	2	BLACK	

ITEM	PART NAME	FOXCONN P/N	DESCRIPTION	Q'TY
⑥	WIRE(YELLOW)	761-2604-001	FOXCONN: UL1007 26AWG	A/R
⑤	WIRE(RED)	761-2602-001		
④	WIRE(BROWN)	761-2601-001		
③	WIRE(BLACK)	761-2600-001		
②	CONTACT	051-10F7-646	FOXCONN: 051-10F7-646	6 PCS
①	HOUSING	012-2006-492	FOXCONN: 012-2006-492	1 PCS

UNITS		mm		Q'TY
X ±	X ±			
.X ±	.X ±			
.XX ±	.XX ±			
.XXX ±	.XXX ±			

THESE DRAWINGS AND SPECIFICATIONS ARE THE PROPERTY OF HON HAI PRECISION IND. CO., LTD. AND SHALL NOT BE REPRODUCED, COPIED, OR TRANSMITTED IN ANY FORM OR BY ANY MEANS, WITHOUT THE WRITTEN CONSENT OF HON HAI PRECISION IND. CO., LTD.

NAME(INTENDED USE)	SANTYO REV/01
PART NO.(INTENDED USE)	012-0004-492 PIGTAIL
APPD:	FW06G94-0F-DF
CHKD:	
DR:	M.H XU 2/23'11

TITLE:	WIRE HARNESS ASS'Y
DWG NO.:	355-0000-****

SCALE	SHEET	REV.
N/A	1/1	X7