

FM50 — Analog Temperature Sensor

Features

- Analog Output: 10mV/°C
- Range: -40 to 125°C Range
- Accuracy: ±2°C at 25°C
- Supply Current: 170µA Maximum
- Output Drive: 25µA
- Self-heating: <0.1°C
- Operating Voltage: +2.4V to +6V

Applications

- Mobile Phones
- Computers
- Battery Management
- Office Equipment
- HVAC
- Power Supply Modules
- Disk Drives
- Automotive

Description

As a precision CMOS temperature sensor, the FM50 is cost effective for accurate, low-power, temperature-monitoring applications. Output voltage versus temperature is extremely linear. With no load, the supply current is typically 130µA. For normal operation, the load on V_{OUT} should be 100KΩ or less.

In a typical application, a remotely mounted FM50 is monitored by a microcontroller with an analog A/D converter input. Alternatively, the FM50 can drive a comparator with a high-impedance input.

Accuracy is typically ±0.5°C at room temperature, and better than ±2°C from 0 to 75°C.

FM50 is available in a 3-pin SOT-23 package.

Ordering Information

Part Number	Operating Temperature Range	Package	Packing Method
FM50S3X	-40 to +125°C	3-Pin SOT-23	3000 Units, Tape and Reel

All packages are lead free per JEDEC: J-STD-020B standard.

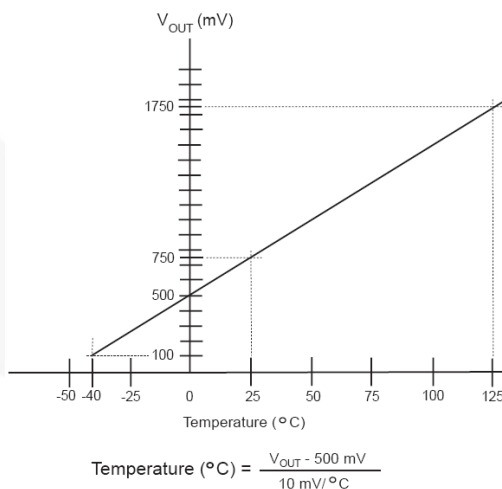

Figure 1. Output Voltage vs. Temperature

Pin Configuration

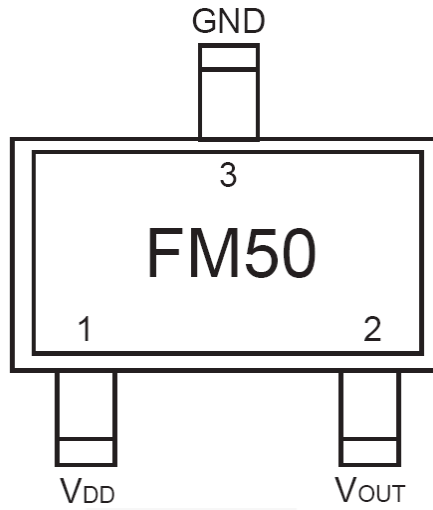

Figure 2. Pin Configuration

Pin Definitions

Pin #	Name	Type	Description
1	V _{DD}	Power	Power Supply. 2.4 to 6.0V.
2	V _{OUT}	Analog Output	Temperature Sensor. Analog output voltage indicating temperature. V _{OUT} = 500+10T(°C) mV.
3	GND	Power	Ground.

Absolute Maximum Ratings

Stresses exceeding the absolute maximum ratings may damage the device. The device may not function or be operable above the recommended operating conditions and stressing the parts to these levels is not recommended. In addition, extended exposure to stresses above the recommended operating conditions may affect device reliability. The absolute maximum ratings are stress ratings only.

Symbol	Parameter	Min.	Max.	Unit
V _{DD}	Supply Voltage		+7	V
V _{OUT}	Output Voltage		V _{DD} +0.5	V
I _{OUT}	Output Current		10	μA
T _J	Operating Temperature Range	-50	+150	°C
T _{STG}	Storage Temperature Range	-60	+150	°C
T _L	Lead Soldering Temperature		+220	°C
ESD	Human Body Model, JESD22-A114 ⁽¹⁾		2000	V
	Machine Model, JESD22-A115 ⁽²⁾		250	

Notes:

- Human body model: 100pF capacitor discharged through a 1.5kW resistor into each pin.
- Machine model: 200pF capacitor discharged directly into each pin.

Electrical Characteristics

Limits apply for $-40^{\circ}\text{C} \leq T_A \leq +125^{\circ}\text{C}$ and $V_{DD}=+5.0\text{V}$ unless otherwise noted. These specifications are guaranteed only for the test conditions listed.

Symbol	Parameter	Conditions	Min.	Typ.	Max.	Units
Transfer Characteristics						
A _{OUT}	Sensitivity		9.7	10.0	10.3	mV/°C
	Output at 25°C		740	750	760	mV
	Accuracy ⁽³⁾	T _A =+25°C	-2.0	±0.5	+2.0	°C
		T _A =-40°C (T _{MIN})	-3.5	±1.0	+3.5	
		T _A =+125°C (T _{MAX})	-3	±1	+3	
T _A	Temperature Range		-40		+125	°C
	Non-Linearity ⁽⁴⁾		-0.8		+0.8	°C
Output						
V _{OUT}	Output Voltage Range		100		1750	mV
I _{ONSN}	Output Current Source	Sensing		25		μA
I _{ONSG}		Surge				mA
I _{OL}	Output Current Sink			50		μA
R _{OUT}	Output Resistance	100kΩ Load at 25°C	1		10	kΩ
R _{LOAD}	Load Regulation					mV/mA
Power						
V _{DD}	Supply Voltage		2.4		6.0	V
I _Q	Quiescent Current	No Output Load			170	μA
Package						
Θ _{JA}	Thermal Resistance			260		°C/W

Notes:

- Accuracy (expressed in °C)= difference between calculated output voltage and measured output voltage. Calculated output voltage =10m/V°C multiplied by the device's case temperature at specific conditions of temperature, voltage and power supply, added to 500mV.
- Non-linearity is defined as the deviation of the output voltage vs. temperature curve from the best fit straight line over the rated temperature range.

Typical Performance Characteristics

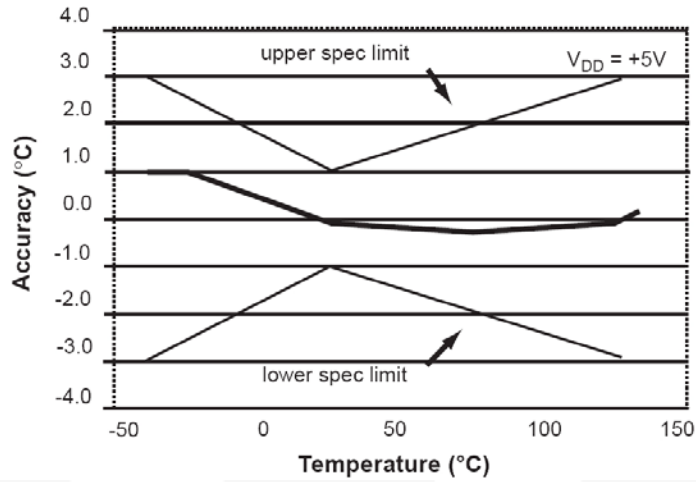

Figure 3. Accuracy vs. Temperature

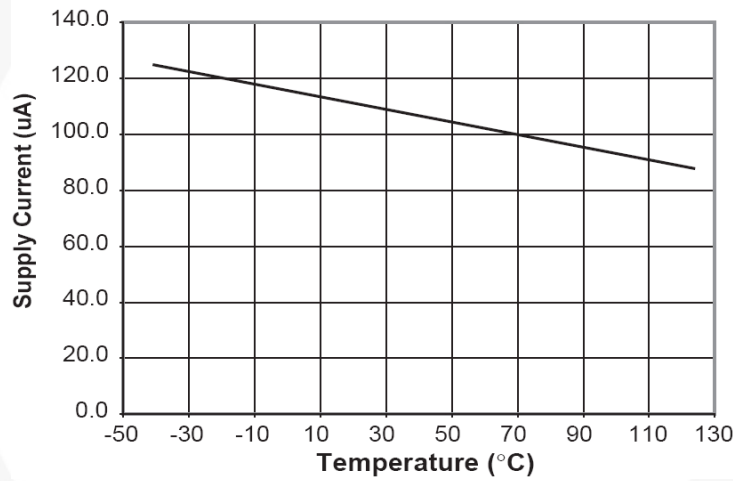

Figure 4. Typical I_{DD} vs. Temperature

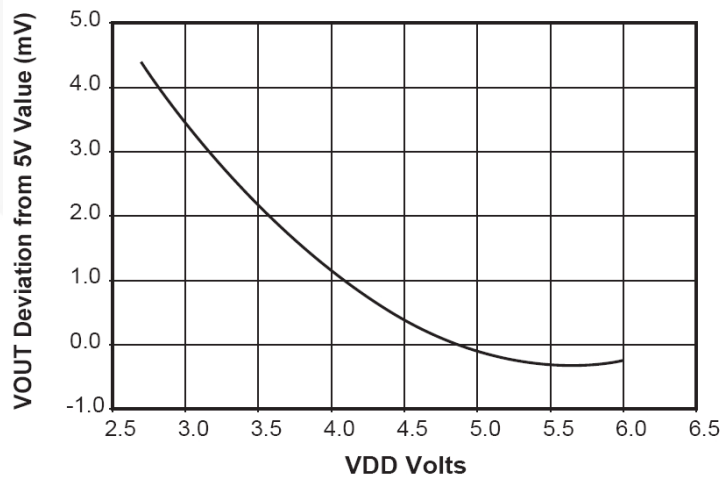

Figure 5. Typical Sensitivity to Supply Voltage

Functional Description

The FM50 contains a thermal diode, calibration circuits, and amplifiers. Since the FM50 is calibrated at 33°C, the nominal output in mV is:

$$V_{OUT} = 830 + 10 \cdot (T - 33) \quad (1)$$

where T is the thermal junction temperature expressed in °C.

At 33°C, the tolerances are:

- Offset is ±3mV.
- Slope is ±0.3mV/°C.

These values accommodate the specified accuracies at -40, +25, and +125°C.

Output structure is an N-channel CMOS transistor driving a P-channel load. Available current is typically 50µA to ground. Series resistance is typically 7kΩ, charging and 2kΩ, discharging through a capacitor connected from V_{OUT} to ground.

Following application of power to V_{DD}, V_{OUT} is accurate after a delay of approximately 80ms.

Application Information

Although the FM50 is a simple device, care must be taken to ensure that temperature is measured accurately. The major sources of errors are:

- Voltage Errors
- Thermal Delay Errors
- Location Errors

Voltage Errors

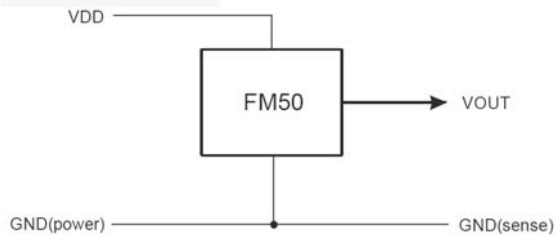

Figure 6. Recommended Electrical Connections

A Kelvin connection is recommended to avoid errors due to voltage drops in the ground connections. Although the typical 130µA supply current draw only causes a 130µV error; if the series resistance is 1Ω, a 100mA current supply to adjacent circuits can cause a 10mV drop across 100mΩ (10mΩ is a typical value for soldered joints or contact resistance), leading to a 1°C error. For this reason, the FM50 should be Kelvin connected, as shown in Figure 6.

Thermal Delay Errors

For measurement accuracy of the order of tenths of 1°C, adequate settling time must be allowed. For a typical circuit board installation, 15 minutes should be allowed to elapse after reading temperature within 1~2°C of the expected final value. Once V_{OUT} has ceased to slew and is stable (with or without about ±0.1°C noise) for about five minutes, temperature can be calculated.

Location Errors

Position is source of error. Even within a controlled thermal environment, changing location by a few inches can lead to errors of several tenths of 1°C.

Mounting

The FM50 can be easily mounted by gluing or cementing it to a surface. In this case, its temperature will be within about 0.2°C of the temperature of the surface to which it is attached if the ambient air temperature is almost the same as the surface temperature. If the air temperature is much higher or lower than the surface temperature, the actual temperature of the die will be at an intermediate temperature between the surface temperature and the air temperature.

To ensure good thermal conductivity, the backside of the die is directly attached to the GND pin. The lands and traces to the FM50 are part of the printed circuit board, for which the temperature is being measured. These printed circuit board lands and traces do not cause the FM50's temperature to deviate from the desired temperature.

Alternatively, the FM50 can be mounted inside a sealed-end metal tube and can be dipped into a bath or screwed into a threaded hole in a tank. As with any IC, the FM50 and accompanying wiring and circuits must be kept insulated and dry to avoid leakage and corrosion. This is especially true if the circuit may operate at cold temperatures where condensation can occur. Printed-circuit coatings and varnishes, such as Humiseal and epoxy paint or dips, can be used to ensure that moisture cannot corrode the FM50 or its connections.

Typical Application Circuits

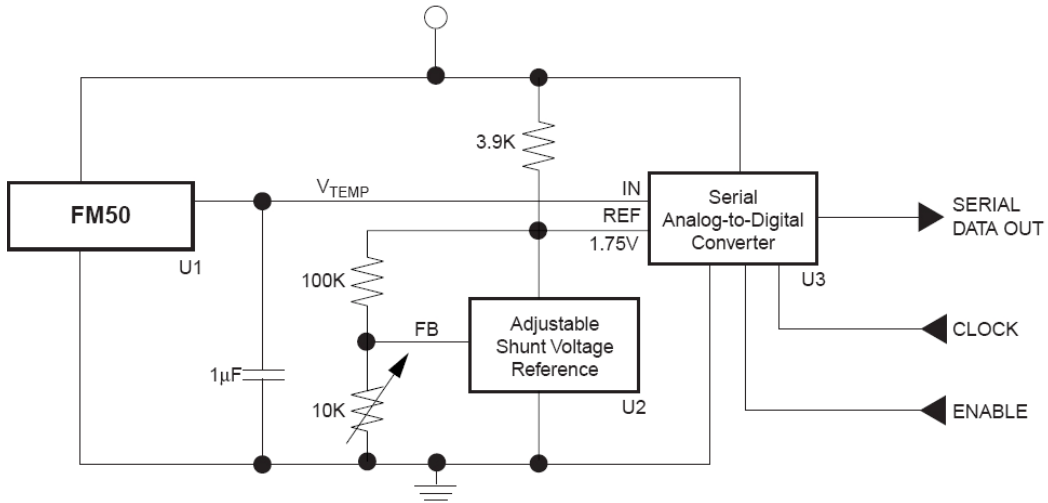

Figure 7. Serial Output Temperature to Digital Converter (Full Scale = +125°C)

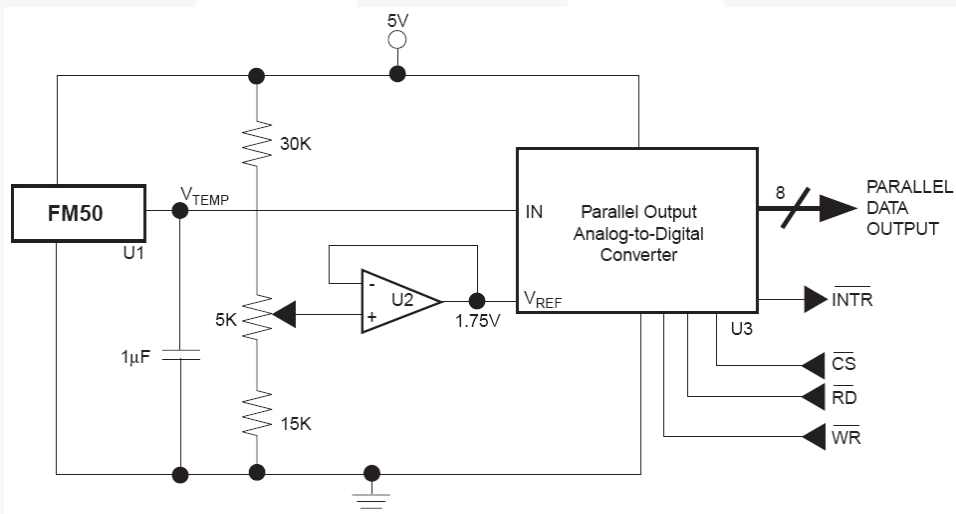

Figure 8. Parallel Output Temperature to Digital Converter (Full Scale = +125°C)

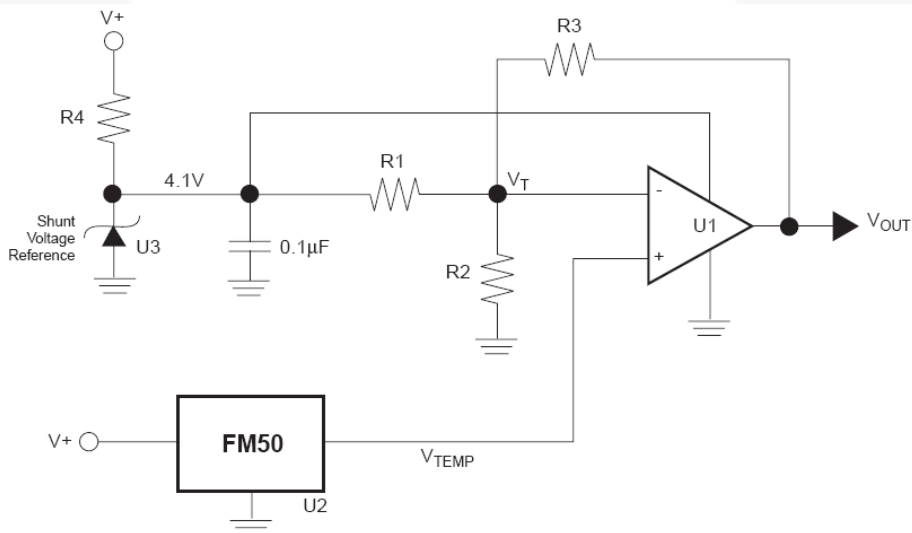
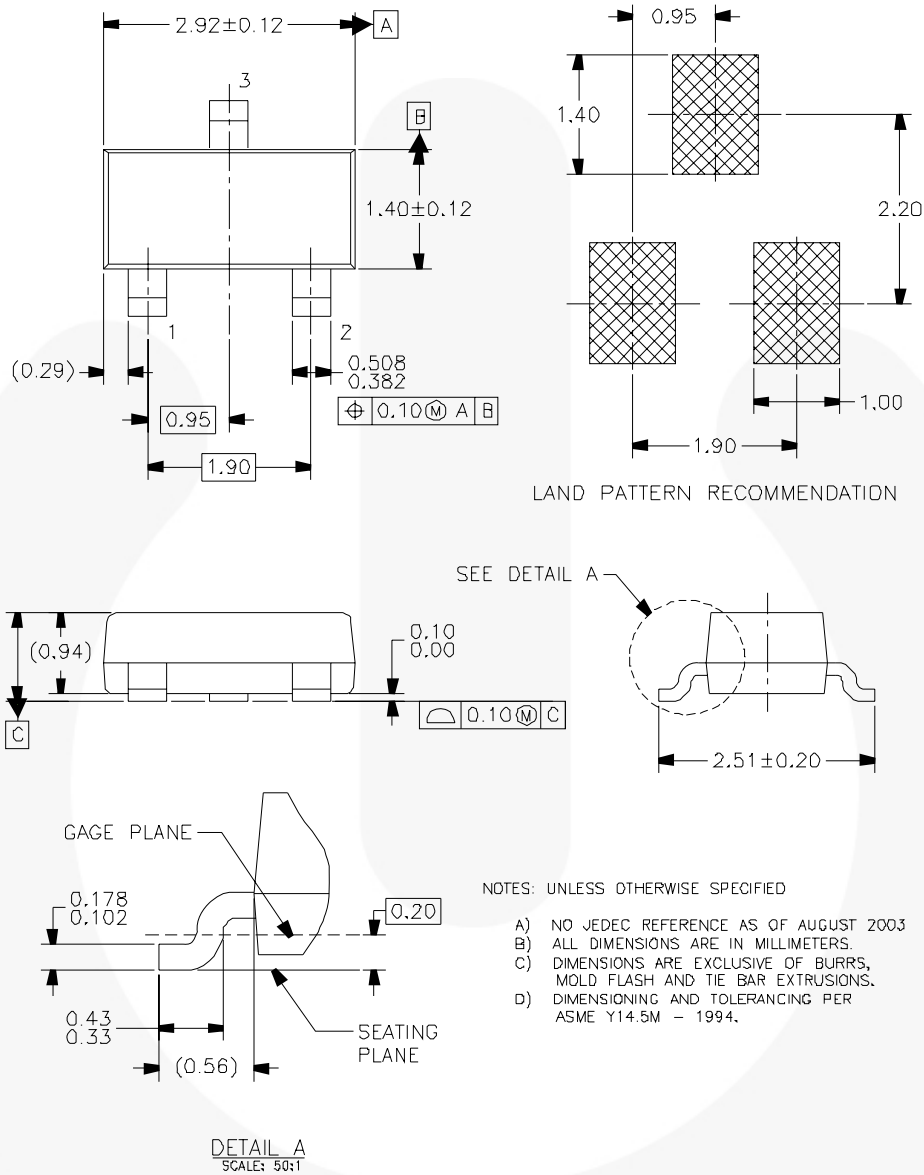

Figure 9. Thermostat / Fan Controller

Physical Dimensions



NA03BREV8

Figure 10. 3-Pin SOT Package





Package drawings are provided as a service to customers considering Fairchild components. Drawings may change in any manner without notice. Please note the revision and/or date on the drawing and contact a Fairchild Semiconductor representative to verify or obtain the most recent revision. Package specifications do not expand the terms of Fairchild's worldwide terms and conditions, specifically the warranty therein, which covers Fairchild products.

Always visit Fairchild Semiconductor's online packaging area for the most recent package drawings:
<http://www.fairchildsemi.com/packaging/>



TRADEMARKS

The following includes registered and unregistered trademarks and service marks, owned by Fairchild Semiconductor and/or its global subsidiaries, and is not intended to be an exhaustive list of all such trademarks.

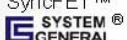
- | | | | |
|---|---|---|---|
| ACEx® | FPST™ | PDP SPM™ | The Power Franchise® |
| Build it Now™ | F-PFS™ | Power-SPM™ |  |
| CorePLUS™ | FRFET® | PowerTrench® | TinyBoost™ |
| CorePOWER™ | Global Power Resource™ | Programmable Active Droop™ | TinyBuck™ |
| CROSSVOLT™ | Green FPST™ | QFET® | TinyLogic® |
| CTL™ | Green FPST™ e-Series™ | QS™ | TINYOPTO™ |
| Current Transfer Logic™ | GTQ™ | Quiet Series™ | TinyPower™ |
| EcoSPARK® | IntelliMAX™ | RapidConfigure™ | TinyPWM™ |
| EfficientMax™ | ISOPLANAR™ | Saving our world, 1mW at a time™ | TinyWire™ |
| EZSWITCH™ * | MegaBuck™ | SmartMax™ | μSerDes™ |
|  | MICROCOUPLER™ | SMART START™ |  |
|  | MicroFET™ | SPM® | UHC® |
| Fairchild® | MicroPak™ | STEALTH™ | Ultra FRFET™ |
| Fairchild Semiconductor® | MillerDrive™ | SuperFET™ | UniFET™ |
| FACT Quiet Series™ | MotionMax™ | SuperSOT™-3 | VCX™ |
| FACT® | Motion-SPM™ | SuperSOT™-6 | VisualMax™ |
| FAST® | OPTOLOGIC® | SuperSOT™-8 | |
| FastvCore™ | OPTOPLANAR® | SupreMOS™ | |
| FlashWriter®* |  | SyncFET™ | |
| | |  | |

* EZSWITCH™ and FlashWriter® are trademarks of System General Corporation, used under license by Fairchild Semiconductor.

DISCLAIMER

FAIRCHILD SEMICONDUCTOR RESERVES THE RIGHT TO MAKE CHANGES WITHOUT FURTHER NOTICE TO ANY PRODUCTS HEREIN TO IMPROVE RELIABILITY, FUNCTION, OR DESIGN. FAIRCHILD DOES NOT ASSUME ANY LIABILITY ARISING OUT OF THE APPLICATION OR USE OF ANY PRODUCT OR CIRCUIT DESCRIBED HEREIN; NEITHER DOES IT CONVEY ANY LICENSE UNDER ITS PATENT RIGHTS, NOR THE RIGHTS OF OTHERS. THESE SPECIFICATIONS DO NOT EXPAND THE TERMS OF FAIRCHILD'S WORLDWIDE TERMS AND CONDITIONS, SPECIFICALLY THE WARRANTY THEREIN, WHICH COVERS THESE PRODUCTS.

LIFE SUPPORT POLICY

FAIRCHILD'S PRODUCTS ARE NOT AUTHORIZED FOR USE AS CRITICAL COMPONENTS IN LIFE SUPPORT DEVICES OR SYSTEMS WITHOUT THE EXPRESS WRITTEN APPROVAL OF FAIRCHILD SEMICONDUCTOR CORPORATION.

As used herein:

1. Life support devices or systems are devices or systems which, (a) are intended for surgical implant into the body or (b) support or sustain life, and (c) whose failure to perform when properly used in accordance with instructions for use provided in the labeling, can be reasonably expected to result in a significant injury of the user.
2. A critical component in any component of a life support, device, or system whose failure to perform can be reasonably expected to cause the failure of the life support device or system, or to affect its safety or effectiveness.

PRODUCT STATUS DEFINITIONS

Definition of Terms

Datasheet Identification	Product Status	Definition
Advance Information	Formative / In Design	This datasheet contains the design specifications for product development. Specifications may change in any manner without notice.
Preliminary	First Production	This datasheet contains preliminary data; supplementary data will be published at a later date. Fairchild Semiconductor reserves the right to make changes at any time without notice to improve design.
No Identification Needed	Full Production	This datasheet contains final specifications. Fairchild Semiconductor reserves the right to make changes at any time without notice to improve the design.
Obsolete	Not In Production	This datasheet contains specifications on a product that is discontinued by Fairchild Semiconductor. The datasheet is for reference information only.

Rev. 134