

346/396 SERIES CARD EDGE CONNECTOR

.125" (3.18mm) Contact Spacing

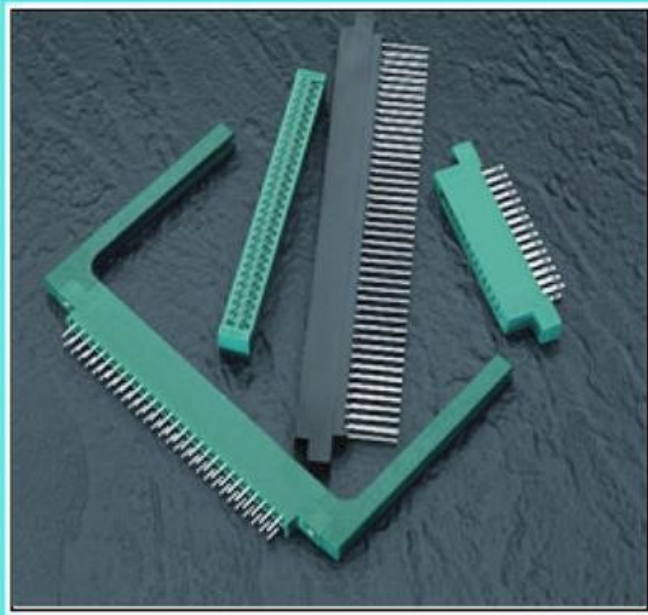

FEATURES

- CSA Approved and UL Recognized
- .125 (3.18) Contact Spacing x .250 (6.35) Row Spacing
- Accepts .062 (1.57) Nominal Thickness P.C. Board
- High Profile Insulator Body, .600 (15.24)
- Contact Termination Options include P.C. Tail, Wire Hole, .025 (0.64) Square Wire Wrap, 90 Degree & Extender Board Bends
- Single or Dual Row Configurations
- Large Variety of Mounting Options, Flush or Offset Lugs
- Pre-assembled Card Guides Available
- Accepts Between Contact and In-Contact Polarizing Keys
- Automatic Wire Wrap Positioning Holes

SPECIFICATIONS

- ◆ Insulator Material: Thermoplastic Polyester, UL 94V-0
- ◆ Contact Material: Copper, Nickel, Tin Alloy CA-725
- ◆ Contact Plating: Gold on the Mating Area, Tin on the Contact Tails, Nickel Underplate
- ◆ Current Rating: 3 Amperes Continuous
- ◆ Contact Resistance: 10 Milliohms Maximum
- ◆ Dielectric Withstanding Voltage: 1500 V AC rms at Sea Level Between Adjacent Contacts
- ◆ Insulation Resistance: 5000 Megohms Minimum
- ◆ Operating Temperature: -65 to +105 Degrees C
- ◆ Insertion Force: 16 oz (4.45 N) Maximum per Contact Pair when Tested with a .070 (1.78) Thick Gauge
- ◆ Withdrawal Force: 1 oz (0.28 N) Minimum per Contact Pair when Tested with a .054 (1.37) Thick Gauge

346/396 SERIES ORDERING CODE

Example Part Number **346 - 056 - 540 - 8 02**

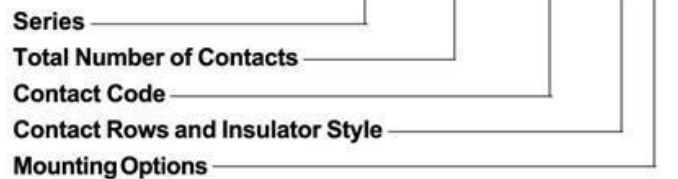

Series	Insulator Colour
346	Green
396	Black

Total Number of Contacts ¹	Contact Rows
005, 006,...050	Single Row
010, 012,...100	Dual Row

Contact Code ^{2,3}	Description & Tail Size	Tail Length "G"
500	Wire Hole .050 x .025 (1.27 x 0.64)	.260 (6.60)
520	P.C. Tail .025 Square (0.64 Square)	.175 (4.45)
521	P.C. Tail .025 Square (0.64 Square)	.150 (3.81)
522	P.C. Tail .025 Square (0.64 Square)	.440(11.18)
526	P.C. Tail .025 Square (0.64 Square)	.350 (8.89)
540	Wire Wrap .025 Square (0.64 Square)	.560(14.22)
541	Wire Wrap .025 Square (0.64 Square)	.750(19.05)
555	Extender Board Bend (Code 500 Contacts)	
556	Extender Board Bend (Code 520 Contacts)	
558	90 Degree Bend (Code 541 Contacts)	
559	90 Degree Bend (Code 541 Contacts)	
560	Extender Board Bend (Code 526 Contacts)	

Contact Rows and Insulator Style ⁴	Description
1	Single Row, Flush Mounting Lugs
2	Dual Row, Flush Mounting Lugs
6	Single Row, .170 (4.32) Offset Lugs
8	Dual Row, .170 (4.32) Offset Lugs

Mounting Options ^{5,6,7}	Description
01	No Mounting Lugs
02	.128 (3.25) Dia. Mounting Holes
03	.116 (2.95) I.D. Floating Eyelets
04	.156 (3.96) Dia. Mounting Holes
07	M3-0.5 Metric Threaded Inserts
08	#4-40 Unified Threaded Inserts
12	.128 (3.25) Dia. Side Mounting Holes
58	.468 (11.89) Offset Card Guides
78	In-Line Card Guides

Ordering Code Notes

- 1) All connector sizes up to 50 contacts single row / 100 contacts dual row are available upon request.
- 2) The 500 contact code is only available in the 346 series. Green polyphenylene sulphide insulator material will be supplied.
- 3) For details of the extender board and 90 degree bends, refer to page 61.
- 4) Consult with Edac regarding connectors with a .420 (10.67) card slot depth.
- 5) For lugless connectors, code 01 mounting, specify contact row codes 1 or 2.
- 6) In-line card guides are only available with offset mounting lugs.
- 7) For details of the mounting options, refer to page 63.

CARD EDGE CONNECTOR SERIES 346/396

Contact Spacing .125" (3.18mm)

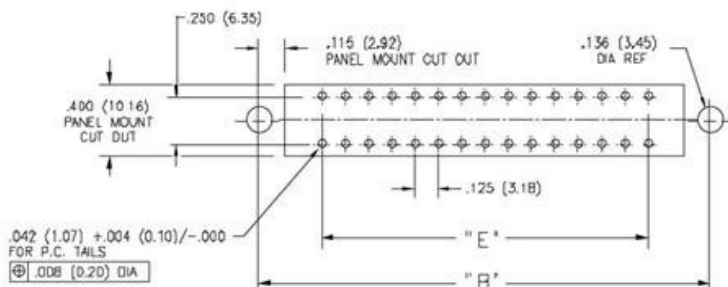
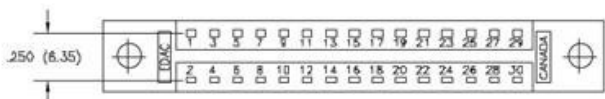
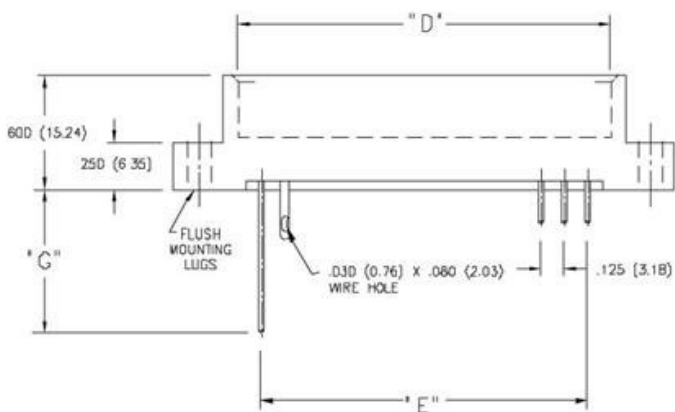
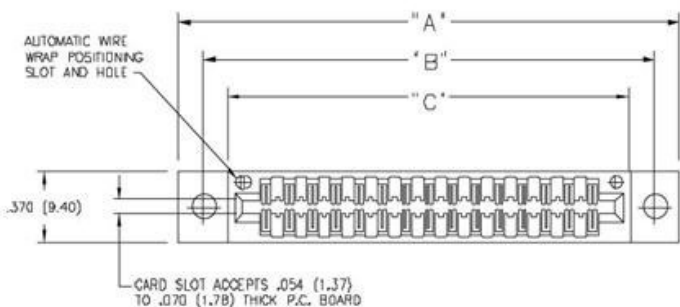

CONNECTOR MOUNTING PATTERN

SECTIONS THROUGH CONTACT POSITION

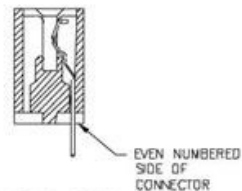

SINGLE ROW

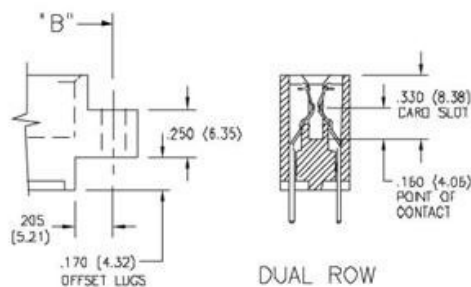

DUAL ROW

IN-CONTACT POLARIZING KEY

P/N 345-240-328

BETWEEN CONTACT POLARIZING KEY

P/N 306-240-318

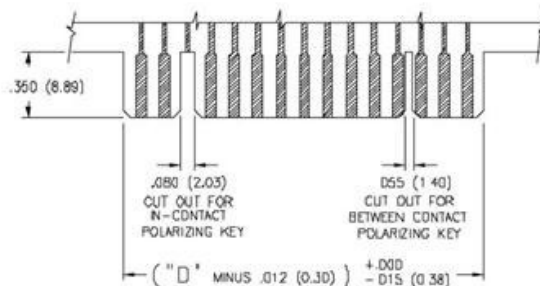

RECOMMENDED DAUGHTER BOARD

NUMBER OF CONTACTS		"A"		"B"		"C"		"D"		"E"	
Single	Dual	Inch	(mm)	Inch	(mm)	Inch	(mm)	Inch	(mm)	Inch	(mm)
5	10	1.435	(36.45)	1.170	(29.72)	.910	(23.11)	.750	(19.05)	.500	(12.70)
6	12	1.560	(39.62)	1.295	(32.89)	1.035	(26.29)	.875	(22.23)	.625	(15.88)
10	20	2.060	(52.32)	1.795	(45.59)	1.535	(38.99)	1.375	(34.93)	1.125	(28.58)
15	30	2.685	(68.20)	2.420	(61.47)	2.160	(54.86)	2.000	(50.80)	1.750	(44.45)
18	36	3.060	(77.72)	2.795	(70.99)	2.535	(64.39)	2.375	(60.33)	2.125	(53.98)
22	44	3.560	(90.42)	3.295	(83.69)	3.035	(77.09)	2.875	(73.03)	2.625	(66.68)
25	50	3.935	(99.95)	3.670	(93.22)	3.410	(86.61)	3.250	(82.55)	3.000	(76.20)
30	60	4.560	(115.82)	4.295	(109.09)	4.035	(102.49)	3.875	(98.43)	3.625	(92.08)
31	62	4.685	(119.00)	4.420	(112.27)	4.160	(105.66)	4.000	(101.60)	3.750	(95.25)
35	70	5.185	(131.70)	4.920	(124.97)	4.660	(118.36)	4.500	(114.30)	4.250	(107.95)
36	72	5.310	(134.87)	5.045	(128.14)	4.785	(121.54)	4.625	(117.48)	4.375	(111.13)
40	80	5.810	(147.57)	5.545	(140.84)	5.285	(134.24)	5.125	(130.18)	4.875	(123.83)
43	86	6.185	(157.10)	5.920	(150.37)	5.660	(143.76)	5.500	(139.70)	5.250	(133.35)
50	100	7.060	(179.32)	6.795	(172.59)	6.535	(165.99)	6.375	(161.93)	6.125	(155.58)

Dimensions of Other Connector Sizes are Listed

CONTACT TAIL BENDS - CARD EDGE CONNECTORS

Standard Bend Details

CONTACT CODE 553 - 90 DEGREE BEND

- Applicable for 307, 322 and 357 Series
- For 307 and 357 Series with .500 (12.70) Connector Width, Longer Contacts are Used and Cut to Length Indicated

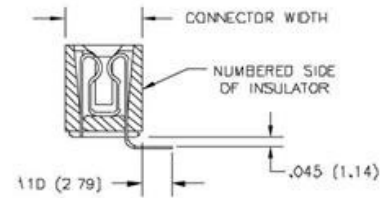

CONTACT CODE 553

CONTACT CODE 554 - 90 DEGREE BEND

- Applicable for 307, 322 and 357 Series
- This Bend is Not Recommended for 307 and 357 Series with .500 (12.70) Connector Width

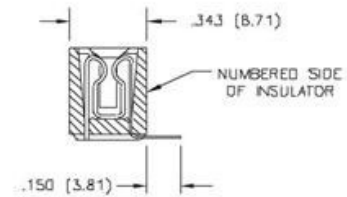

CONTACT CODE 554
BEND USES WIRE HOLE CONTACTS

CONTACT CODE 555 - EXTENDER BOARD BEND

Applicable Series	"A"
305, 307, 310, 315, 322, 355, 357	.265 (6.73)
333, 337, 340, 345, 346, 379, 387, 395, 395-AT, 396	.245 (6.22)
341, 391	.205 (5.21)
342, 392	.255 (6.48)

- For Contact Bend to Accept .125 (3.18) Thick Extender Board, Specify Contact Code 552

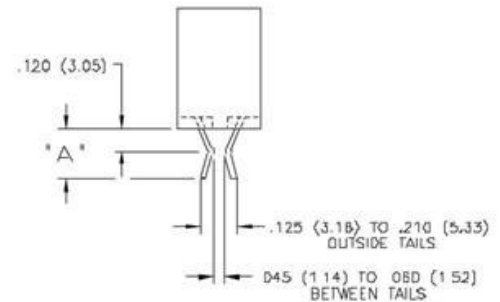

CONTACT CODE 555
BEND USES WIRE HOLE CONTACTS

CONTACT CODE 556 - EXTENDER BOARD BEND

Applicable Series	"A"
305, 307, 310, 315, 322, 355, 357	.195 (4.95)
333, 337, 340, 345, 346, 379, 387, 395, 395-AT, 396	.170 (4.32)
341, 391	.235 (5.97)
342, 392	.180 (4.57)

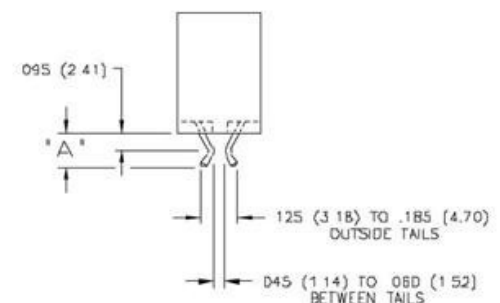

CONTACT CODE 556

CARD EDGE CONNECTORS - CONTACT TAIL BENDS

Standard Bend Details

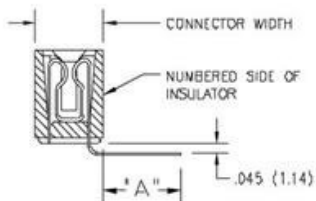

CONTACT CODE 557

CONTACT CODE 557 - 90 DEGREE BEND

Applicable Series	Connector Width	"A"
307, 322, 357	.343 (8.71)	.392 (9.96)
305, 357	.500 (12.70)	.314 (7.98)

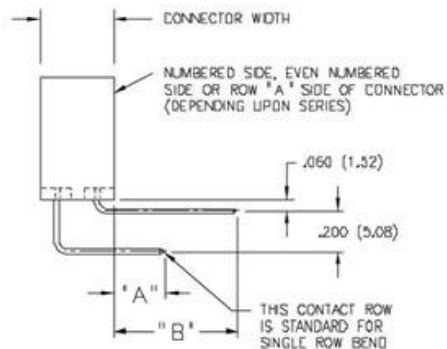

CONTACT CODE 558

CONTACT CODE 558 - 90 DEGREE BEND

Applicable Series	Connector Width	"A"	"B"
307, 322, 357	.343 (8.71)	.240 (6.10)	.240 (6.10)
307, 357	.500 (12.70)	.162 (4.11)	.162 (4.11)
333, 337, 340, 345, 387, 395, 395-AT	.370 (9.40)	.235 (5.97)	.635 (16.13)
342, 392	.370 (9.40)	.245 (6.22)	.645 (16.38)
346, 396	.370 (9.40)	.210 (5.33)	.660 (16.76)

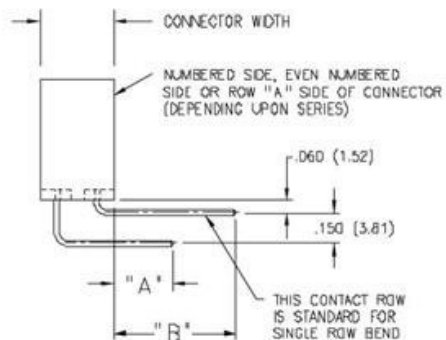

CONTACT CODE 559

CONTACT CODE 559 - 90 DEGREE BEND

Applicable Series	Connector Width	"A"	"B"
307, 322, 357	.343 (8.71)	.290 (7.37)	.240 (6.10)
307, 357	.500 (12.70)	.212 (5.38)	.162 (4.11)
333, 337, 340, 345, 387, 395, 395-AT	.370 (9.40)	.285 (7.24)	.635 (16.13)
342, 392	.370 (9.40)	.295 (7.49)	.645 (16.38)
346, 396	.370 (9.40)	.260 (6.60)	.660 (16.76)

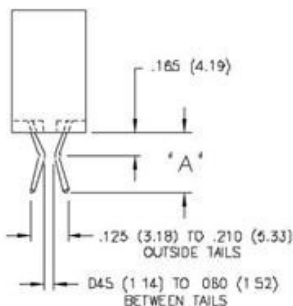

CONTACT CODE 560

CONTACT CODE 560 - EXTENDER BOARD BEND

Applicable Series	"A"
307, 310, 322, 357	.343(8.71)
333, 337, 340, 345, 379, 387, 395, 395-AT	.375(9.53)
341, 391	.365(9.27)
342, 392	.385(9.78)
346, 396	.335(8.51)

MOUNTING OPTIONS - CARD EDGE CONNECTORS

Standard Mounting Details

CODE x01 - NO MOUNTING LUGS

- Applicable for 303, 305, 306, 307, 310, 315, 316, 317, 321, 325, 327, 333, 336, 337, 338, 340, 341, 342, 345, 346, 355, 356, 357, 379, 384, 387, 391, 392, 395 and 396 Series

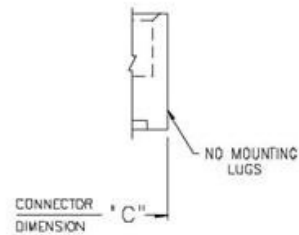

MOUNTING OPTION
CODE x01

CODE x02, x04 & x09 - THROUGH MOUNTING HOLES

Applicable Series	Code x02 "A" Dia.	Code x04 "A" Dia.	Code x09 "A" Dia.
305, 306, 307, 310, 315, 316, 321, 333, 337, 338, 340, 341, 345, 346, 355, 356, 357, 379, 384, 387, 391, 395, 396	.128 (3.25)	.156 (3.96)	—
317, 323	.144 (3.66)	.156 (3.96)	—
325	—	—	.160 (4.06)
327	—	—	.163 (4.14)
342, 392	.128(3.25) x .146 (3.71) Slot	.156 (3.96)	—

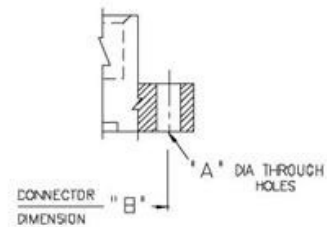

MOUNTING OPTION
CODES x02, x04 & x09

CODE x03 - FLOATING EYELETS

Applicable Series	"A"
305, 306, 307, 310, 315, 316, 317, 321, 323, 333, 337, 338, 341, 345, 346, 355, 356, 357, 379, 384, 387, 391, 395, 396	.328 (8.33)
342, 392	.348 (8.84)

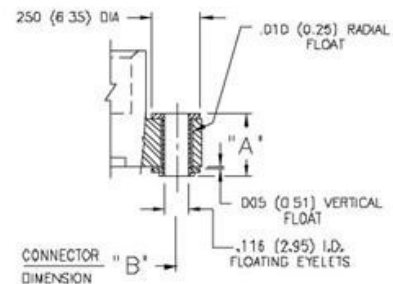

MOUNTING OPTION
CODE x03

CODE x07 & x08 - THREADED INSERTS

- Applicable for 305, 306, 307, 310, 315, 316, 317, 321, 323, 325, 333, 337, 338, 341, 342, 345, 346, 356, 357, 379, 384, 387, 391, 392, 395 and 396 Series
- See Code x12 for Side Mounting Threaded Inserts

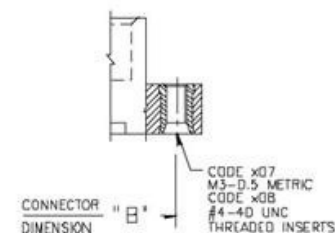

MOUNTING OPTION
CODES x07 & x08

CODE x12 - SIDE MOUNTING HOLES

Applicable Series	"A"
307, 333, 337, 345, 346, 357, 387, 395, 396	.125 (3.18)
342, 392	.135 (3.43)

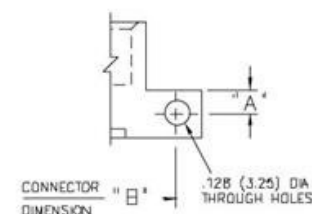

MOUNTING OPTION
CODE x12

- Series Listed Above based on Availability of 90 Degree Bend Contact Tails. Side Mounting Holes may also be Used for Other Card Edge Connectors with a Lug Height of .250 (6.35) or Greater.
- For Side Mounting with Threaded Inserts, Specify Code x17 for M3-0.5 Metric Threads or Code x18 for #4-40 Unified Threads.

CARD EDGE CONNECTORS - MOUNTING OPTIONS

Standard Mounting Details

CODE x58 & x68 - OFFSET CARD GUIDES

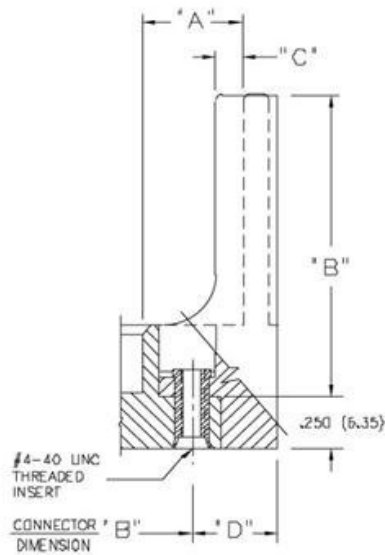

MOUNTING OPTION
CODES x58 & x68

Applicable Series for Code x58 Guides	"A"	"B"	"C"	"D"
305, 306, 307, 315, 316, 337, 338, 355, 356, 357, 387	.468(11.89)	2.755(69.98)	.125(3.18)	.423(10.74)
345, 395	.468(11.89)	2.755(69.98)	.120(3.05)	.402(10.21)
346, 396	.468(11.89)	2.755(69.98)	.120(3.05)	.398(10.11)

Applicable Series for Code x68 Guides	"A"	"B"	"C"	"D"
305, 306, 307, 315, 316, 337, 338, 355, 356, 357, 387	.344 (8.74)	2.505(63.63)	.060(1.52)	.242 (6.15)

- For Card Guides with .128 (3.25) Dia. Through Hole Inserts, Specify Code x52 or x62.
- For Card Guides with M3-0.5 Metric Threaded Inserts, Specify Code x57 or x67.
- For Field Assembly of Card Guides, Refer to Page 72.

CODE x78 & x88 - IN-LINE CARD GUIDES

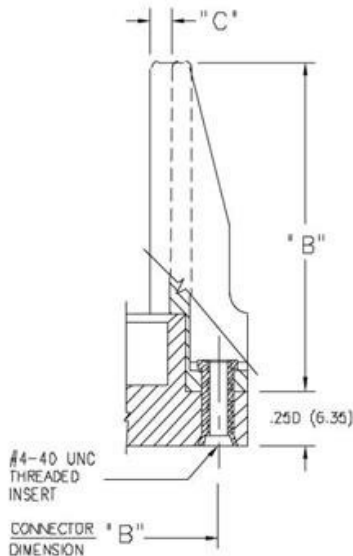

MOUNTING OPTION
CODES x78 & x88

Applicable Series for Code x78 Guides	"B"	"C"
305, 306, 307, 315, 316, 337, 338, 355, 356, 357, 387	1.550(39.37)	.090(2.29)
317	1.712(43.48)	.110(2.79)
345, 395	2.750(69.85)	.083(2.11)
346, 396	2.750(69.85)	.091(2.31)

Applicable Series for Code x88 Guides	"B"	"C"
345, 395	1.250(31.75)	.083(2.11)

- In-Line Card Guides are Not Suitable for the Flush Mounting Lug Versions of 337, 387, 346 or 396 Series
- For Card Guides with .128 (3.25) Dia. Through Hole Inserts, Specify Code x72 or x82.
- For Card Guides with M3-0.5 Metric Threaded Inserts, Specify Code x77 or x87
- For Field Assembly of Card Guides, Refer to Page 72.

.125" (3.18mm) CONTACT SPACING CONNECTOR DIMENSIONS

346, 396, 746 Series Card Edge Connectors

DIMENSION		"A"		"B"		"C"		"D"		"E"	
SERIES		346, 396		346, 396		ALL SERIES		ALL SERIES		ALL SERIES	
Number of Contacts Single	Dual	Inch (mm)		Inch (mm)		Inch (mm)		Inch (mm)		Inch (mm)	
5	10	1.435	(36.45)	1.170	(29.72)	.910	(23.11)	.750	(19.05)	.500	(12.70)
6	12	1.560	(39.62)	1.295	(32.89)	1.035	(26.29)	.875	(22.23)	.625	(15.88)
7	14	1.685	(42.80)	1.420	(36.07)	1.160	(29.46)	1.000	(25.40)	.750	(19.05)
8	16	1.810	(45.97)	1.545	(39.24)	1.285	(32.64)	1.125	(28.58)	.875	(22.23)
9	18	1.935	(49.15)	1.670	(42.42)	1.410	(35.81)	1.250	(31.75)	1.000	(25.40)
10	20	2.060	(52.32)	1.795	(45.59)	1.535	(38.99)	1.375	(34.93)	1.125	(28.58)
11	22	2.185	(55.50)	1.920	(48.77)	1.660	(42.16)	1.500	(38.10)	1.250	(31.75)
12	24	2.310	(58.67)	2.045	(51.94)	1.785	(45.34)	1.625	(41.28)	1.375	(34.93)
13	26	2.435	(61.85)	2.170	(55.12)	1.910	(48.51)	1.750	(44.45)	1.500	(38.10)
14	28	2.560	(65.02)	2.295	(58.29)	2.035	(51.69)	1.875	(47.63)	1.625	(41.28)
15	30	2.685	(68.20)	2.420	(61.47)	2.160	(54.86)	2.000	(50.80)	1.750	(44.45)
16	32	2.810	(71.37)	2.545	(64.64)	2.285	(58.04)	2.125	(53.98)	1.875	(47.63)
17	34	2.935	(74.55)	2.670	(67.82)	2.410	(61.21)	2.250	(57.15)	2.000	(50.80)
18	36	3.060	(77.72)	2.795	(70.99)	2.535	(64.39)	2.375	(60.33)	2.125	(53.98)
19	38	3.185	(80.90)	2.920	(74.17)	2.660	(67.56)	2.500	(63.50)	2.250	(57.15)
20	40	3.310	(84.07)	3.045	(77.34)	2.785	(70.74)	2.625	(66.68)	2.375	(60.33)
21	42	3.435	(87.25)	3.170	(80.52)	2.910	(73.91)	2.750	(69.85)	2.500	(63.50)
22	44	3.560	(90.42)	3.295	(83.69)	3.035	(77.09)	2.875	(73.03)	2.625	(66.68)
23	46	3.685	(93.60)	3.420	(86.87)	3.160	(80.26)	3.000	(76.20)	2.750	(69.85)
24	48	3.810	(96.77)	3.545	(90.04)	3.285	(83.44)	3.125	(79.38)	2.875	(73.03)
25	50	3.935	(99.95)	3.670	(93.22)	3.410	(86.61)	3.250	(82.55)	3.000	(76.20)
26	52	4.060	(103.12)	3.795	(96.39)	3.535	(89.79)	3.375	(85.73)	3.125	(79.38)
27	54	4.185	(106.30)	3.920	(99.57)	3.660	(92.96)	3.500	(88.90)	3.250	(82.55)
28	56	4.310	(109.47)	4.045	(102.74)	3.785	(96.14)	3.625	(92.08)	3.375	(85.73)
29	58	4.435	(112.65)	4.170	(105.92)	3.910	(99.31)	3.750	(95.25)	3.500	(88.90)
30	60	4.560	(115.82)	4.295	(109.09)	4.035	(102.49)	3.875	(98.43)	3.625	(92.08)
31	62	4.685	(119.00)	4.420	(112.27)	4.160	(105.66)	4.000	(101.60)	3.750	(95.25)
32	64	4.810	(122.17)	4.545	(115.44)	4.285	(108.84)	4.125	(104.78)	3.875	(98.43)
33	66	4.935	(125.35)	4.670	(118.62)	4.410	(112.01)	4.250	(107.95)	4.000	(101.60)
34	68	5.060	(128.52)	4.795	(121.79)	4.535	(115.19)	4.375	(111.13)	4.125	(104.78)
35	70	5.185	(131.70)	4.920	(124.97)	4.660	(118.36)	4.500	(114.30)	4.250	(107.95)
36	72	5.310	(134.87)	5.045	(128.14)	4.785	(121.54)	4.625	(117.48)	4.375	(111.13)
37	74	5.435	(138.05)	5.170	(131.32)	4.910	(124.71)	4.750	(120.65)	4.500	(114.30)
38	76	5.560	(141.22)	5.295	(134.49)	5.035	(127.89)	4.875	(123.83)	4.625	(117.48)
39	78	5.685	(144.40)	5.420	(137.67)	5.160	(131.06)	5.000	(127.00)	4.750	(120.65)
40	80	5.810	(147.57)	5.545	(140.84)	5.285	(134.24)	5.125	(130.18)	4.875	(123.83)
41	82	5.935	(150.75)	5.670	(144.02)	5.410	(137.41)	5.250	(133.35)	5.000	(127.00)
42	84	6.060	(153.92)	5.795	(147.19)	5.535	(140.59)	5.375	(136.53)	5.125	(130.18)
43	86	6.185	(157.10)	5.920	(150.37)	5.660	(143.76)	5.500	(139.70)	5.250	(133.35)
44	88	6.310	(160.27)	6.045	(153.54)	5.785	(146.94)	5.625	(142.88)	5.375	(136.53)
45	90	6.435	(163.45)	6.170	(156.72)	5.910	(150.11)	5.750	(146.05)	5.500	(139.70)
46	92	6.560	(166.62)	6.295	(159.89)	6.035	(153.29)	5.875	(149.23)	5.625	(142.88)
47	94	6.685	(169.80)	6.420	(163.07)	6.160	(156.46)	6.000	(152.40)	5.750	(146.05)
48	96	6.810	(172.97)	6.545	(166.24)	6.285	(159.64)	6.125	(155.58)	5.875	(149.23)
49	98	6.935	(176.15)	6.670	(169.42)	6.410	(162.81)	6.250	(158.75)	6.000	(152.40)
50	100	7.060	(179.32)	6.795	(172.59)	6.535	(165.99)	6.375	(161.93)	6.125	(155.58)
51	102					6.660	(169.16)	6.500	(165.10)	6.250	(158.75)
52	104					6.785	(172.34)	6.625	(168.28)	6.375	(161.93)
53	106					6.910	(175.51)	6.750	(171.45)	6.500	(165.10)
54	108					7.035	(178.69)	6.875	(174.63)	6.625	(168.28)
55	110					7.160	(181.86)	7.000	(177.80)	6.750	(171.45)
56	112					7.285	(185.04)	7.125	(180.98)	6.875	(174.63)
57	114					7.410	(188.21)	7.250	(184.15)	7.000	(177.80)
58	116					7.535	(191.39)	7.375	(187.33)	7.125	(180.98)
59	118					7.660	(194.56)	7.500	(190.50)	7.250	(184.15)
60	120					7.785	(197.74)	7.625	(193.68)	7.375	(187.33)

