



Endicott Research Group, Inc.

2601 Wayne St., Endicott, NY 13760  
607-754-9187 Fax 607-754-9255  
<http://www.ergpower.com>

# SE23605CF



## Specifications and Applications Information

08/16/07

Preliminary

### 8m Class DC to AC Inverter

The SE23605CF (S-Series) dc to ac inverter is specifically designed to power the NEC NL6448BC20-20 display to a moderate brightness level from a +12 volt dc source.

The SE23605CF's small size and encapsulated package make it the ideal power source for applications where size, high efficiency and reliability are critical.

This standard inverter is designed to satisfy the most common cold-cathode lighting requirements for the display. Custom units, providing different inputs, outputs or package refinements are available.

S-Series

### Package Configuration

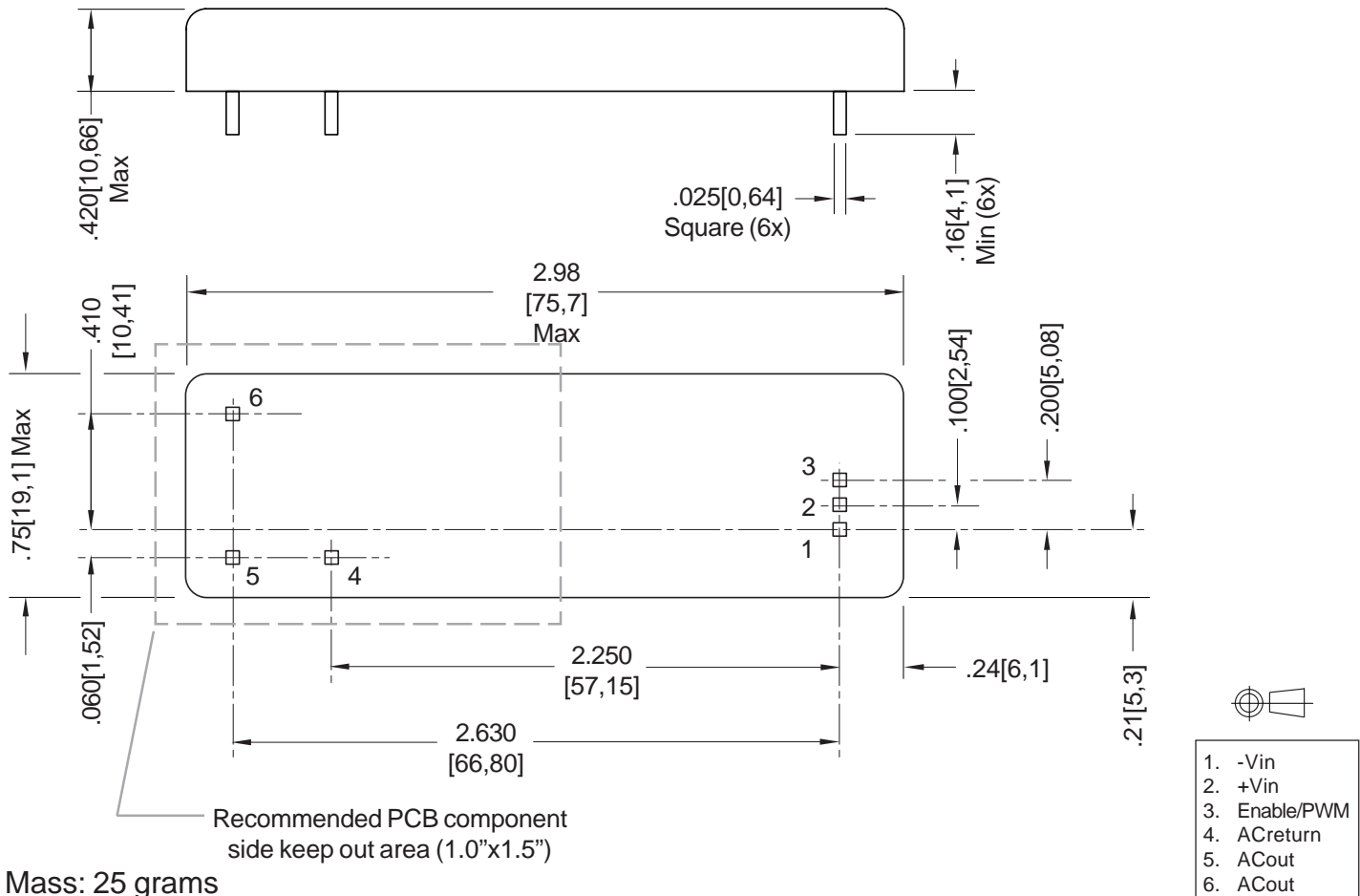

1. -Vin
2. +Vin
3. Enable/PWM
4. ACreturn
5. ACout
6. ACout

## Absolute Maximum Ratings

Rating	Symbol	Value	Units
Input Voltage Range	Vin	-0.3 to +13.2	Vdc
Storage Temperature	Tstg	-40 to +85	°C

## Operating Characteristics

With the referenced display and lamp warm-up of 5 minutes.  
Unless otherwise noted Vin = 12.00 Volts dc and Ta = 25°C.

Characteristic	Symbol	Min	Typ	Max	Units
Input Voltage	Vin	+10.8	+12.0	+12.6	Vdc
Component surface Temperature (note 2)	Ts	-20	-	+80	°C
Input Current (note 1)	Iin	-	0.35	0.40	Adc
Operating Frequency	Fo	45	50	55	kHz
Minimum Output Voltage (note 3)	Vout (min)	1000	-	-	Vrms
Efficiency	<b>h</b>	-	87	-	%
Output Current (per lamp)	Iout	-	5.1	-	mArms
Output Voltage	Vout	-	360	-	Vrms
Enable Pin Input Current Requirement (note 4)	Ien	-	3.65	-	mAdc

Specifications subject to change without notice.

(Note 1) Input current in excess of maximum may indicate a load/inverter mismatch condition, which can result in reduced reliability. Please contact ERG technical support.

(Note 2) Surface temperature must not exceed 80 degrees C; thermal management actions may be required.

(Note 3) Provided data is not tested but guaranteed by design.

(Note 4) Required User Enable/Disable Interface Circuit is shown on page 3.

### Application Notes:

- 1) Printed circuit boards to be free of traces beneath the inverter.
- 2) The minimum distance from high voltage areas of the inverter to any conductive material should be .12 inches per kilovolt of starting voltage.
- 3) Contact ERG for possible exceptions.



Endicott Research Group, Inc.

2601 Wayne St., Endicott, NY 13760  
607-754-9187 Fax 607-754-9255  
<http://www.ergpower.com>

Made in USA



## PWM Dimming

### Required User Enable/Disable Interface Circuit

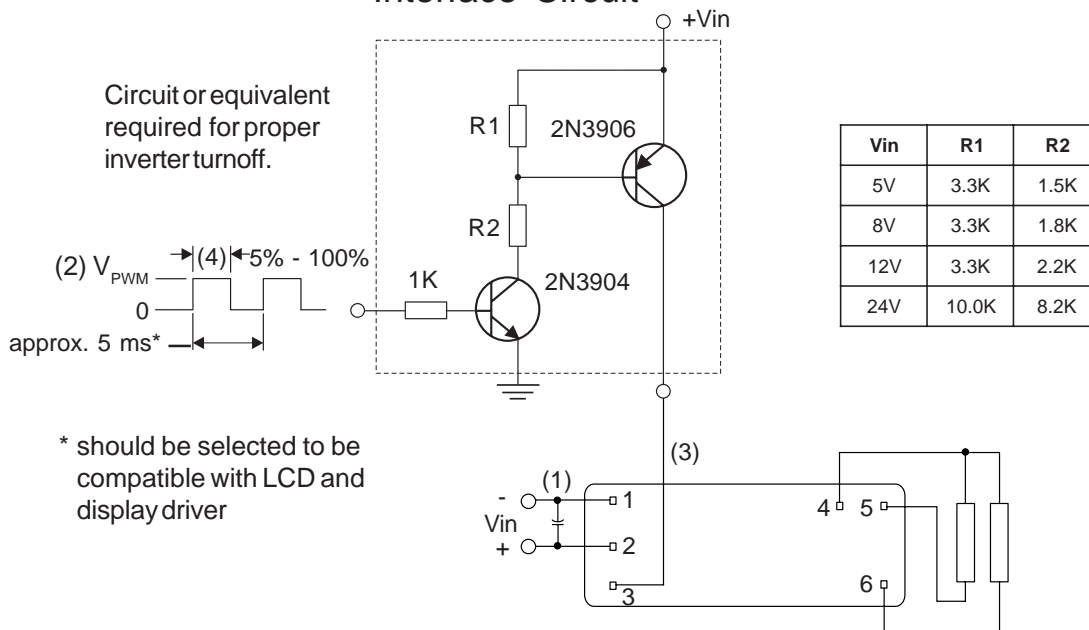

- (1) Low ESR type input by-pass capacitor (22 uf - 100 uf) may be required to reduce reflected ripple.
- (2)  $V_{PWM}$  from 2.4V to less than or equal to 13.2V.
- (3) Full brightness without PWM control requires that pin 3 be tied to  $V_{in}(+)$ . Pin 3 must be at 0V to turn off.
- (4) Duty Cycle 5% - 100%.



Endicott Research Group, Inc. (ERG) reserves the right to make changes in circuit design and/or specifications at any time without notice. Accordingly, the reader is cautioned to verify that data sheets are current before placing orders. Information furnished by ERG is believed to be accurate and reliable. However, no responsibility is assumed by ERG for its use.