

RECOMMENDED P.C.B. LAYOUT
TOLERANCE UNSPECIFIED ±0.05mm

USB TYPE-C FULL-FEATURED RECEPTACLE INTERFACE PIN ASSIGNMENTS

PIN	Signal Name	Description	PIN	Signal Name	Description
A5	CC1	Configuration Channel	B12	GND	Ground return
A9	VBUS	Bus Power	B9	VBUS	Bus Power
A12	GND	Ground return	B5	CC2	Configuration Channel

MATERIAL:

- 1.HOUSING: LCP, GLASS FIBER FILLED, BK
- 2.CONTACT: COPPER ALLOY (T=0.15mm)
- 3.SHELL: STAINLESS STEEL
- 4.MID PLATE: STAINLESS STEEL

FINISH:

- CONTACT: SEE ORDER INFORMATION
SHELL: NICKEL PLATING

Ordering Code:

CU32 06 S A C C L R 001 -LF
① ② ③ ④ ⑤ ⑥ ⑦ ⑧ ⑨ ⑩

- ① Series No.CU32
- ② No of Circuits:06Pin
- ③ S= Socket
- ④ Plating option:
A= Gold Flash plated on Contact area,
Matte Tin plated on Solderails,
Nickel underplating over all
- ⑤ Shell Material & Plating:
C=SUS 201 NI Plated
- ⑥ Contact Material: C=Copper Alloy
- ⑦ Insulator Material & Color option:
L=LCP Black
- ⑧ Packing R= Tape & Reel
- ⑨ 001= H: 1.10mm , 002= H: 2.0mm.
- ⑩ -LF= For Lead Free IR Reflow Process

Lead Free Process

RoHS Compliant

SYM	NAME	DATE	REVISIONS	DRAWN BY:	ENGINEER:	CHECKED BY:	APPROVED BY:	DATE	UNIT: mm / inch	TOLERANCE UNLESS OTHERWISE SPECIFIED	TITLE:
4				Ash	Ash	Keny	Keny	09/23-22'	mm / inch	.X ± 0.25/.010 X' ± 4'	CU32 TYPE C FEMALE CH1.68 H=3.16mm SMT TYPE
3				Ash	Ash	Keny	Keny	09/23-22'	mm / inch	.XX ± 0.20/.008 .X' ± 2'	MATERIAL:
2				Ash	Ash	Keny	Keny	09/23-22'	mm / inch	.XXX ± 0.10/.004 .XX' ±	FINISH:
1				Ash	Ash	Keny	Keny	09/23-22'	mm / inch		



瀚荃股份有限公司
CviLux Corporation

DRAWING NO.	CU32S11SD	PART NO.	CU3206SACCLR001-LF
SCALE	1 / 1	SHEET	1 OF 2

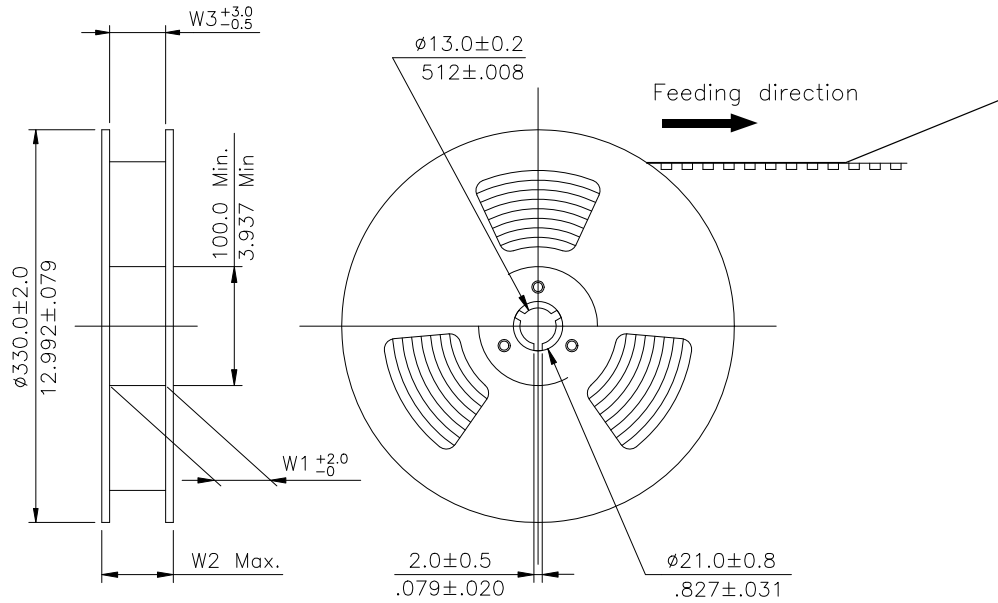

NOTE :

- * Reel Material : HIPS
- * Carrier Material : Clear, Conductive Polystyrene Alloy
- * Cover Tape Material : Polyester
- * Cover Tape Peel Strength : 0.1N – 1.3N
- * Carrier camber is within 1mm in 250mm
- * All dimensions meet EIA-481-B requirements.
- * Quantity : 1000 PCS/Reel

Dimension				Packing (Reel/Carton)
E	W1	W2	W3	
16.0(.630)	16.5(.650)	20.5(.807)	16.5(.650)	15

Feeding direction

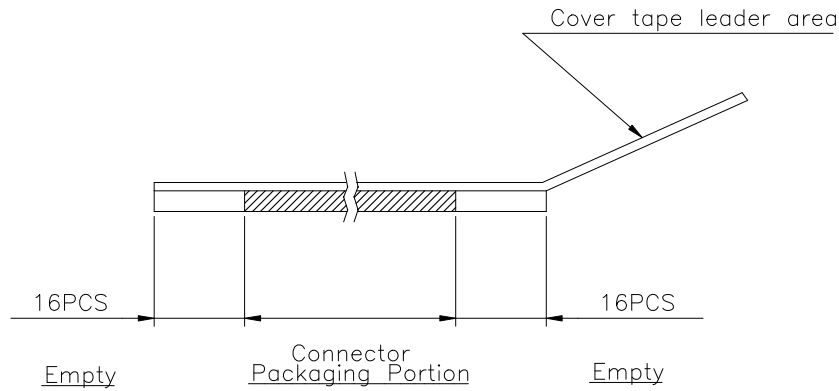
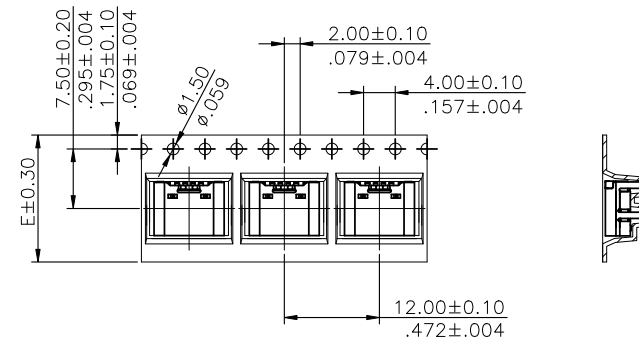

Lead Free Process

RoHS Compliant

4				DATE	UNIT: mm / inch	TITLE:	
3				DRAWN BY: Ash	09/23-22'	CU32 TYPE C FEMALE CH1.68 H=3.16mm SMT TYPE	
2				ENGINEER: Ash	09/23-22'	MATERIAL:	
1				CHECKED BY: Keny	09/23-22'		FINISH:
SYM	NAME	DATE	REVISIONS	APPROVED BY: Keny	09/23-22'		



瀚荃股份有限公司
CviLux Corporation

DRAWING NO.	CU32S11SD	PART NO.	CU3206SACCLR001-LP
SCALE	1 / 1	SHEET	2 OF 2