



**ADVANCE
INFORMATION**

**CY7C1610KV18, CY7C1625KV18
CY7C1612KV18, CY7C1614KV18**

144-Mbit QDR™-II SRAM 2-Word Burst Architecture

Features

- Separate independent read and write data ports
 - Supports concurrent transactions
- 333 MHz clock for high bandwidth
- 2-word burst on all accesses
- Double Data Rate (DDR) interfaces on both read and write ports (data transferred at 666 MHz) at 333 MHz
- Two input clocks (K and \bar{K}) for precise DDR timing
 - SRAM uses rising edges only
- Two input clocks for output data (C and \bar{C}) to minimize clock skew and flight time mismatches
- Echo clocks (CQ and \bar{CQ}) simplify data capture in high speed systems
- Single multiplexed address input bus latches address inputs for read and write ports
- Separate port selects for depth expansion
- Synchronous internally self timed writes
- QDR™-II operates with 1.5 cycle read latency when DOFF is asserted HIGH
- Operates similar to QDR I device with 1 cycle read latency when DOFF is asserted LOW
- Available in x8, x9, x18, and x36 configurations
- Full data coherency providing most current data
- Core VDD = 1.8V(±0.1V); IO VDDQ = 1.4V to VDD
- Available in 165-ball FBGA package (15 x 17 x 1.4 mm)
- Offered in both Pb-free and non Pb-free packages
- Variable drive HSTL output buffers
- JTAG 1149.1 compatible test access port
- Phase Locked Loop (PLL) for accurate data placement

Configurations

- CY7C1610KV18 – 16M x 8
- CY7C1625KV18 – 16M x 9
- CY7C1612KV18 – 8M x 18
- CY7C1614KV18 – 4M x 36

Functional Description

The CY7C1610KV18, CY7C1625KV18, CY7C1612KV18, and CY7C1614KV18 are 1.8V Synchronous Pipelined SRAMs, equipped with QDR-II architecture. QDR-II architecture consists of two separate ports to access the memory array. The read port has dedicated data outputs to support read operations and the write port has dedicated data inputs to support write operations. QDR-II architecture has separate data inputs and data outputs to completely eliminate the need to turn around the data bus that exists with common IO devices. Each port is accessed through a common address bus. The read address is latched on the rising edge of the K clock and the write address is latched on the rising edge of the \bar{K} clock. Accesses to the QDR-II read and write ports are completely independent of one another. To maximize data throughput, both read and write ports are equipped with DDR interfaces. Each address location is associated with two 8-bit words (CY7C1610KV18), 9-bit words (CY7C1625KV18), 18-bit words (CY7C1612KV18), or 36-bit words (CY7C1614KV18) that burst sequentially into or out of the device. Because data is transferred into and out of the device on every rising edge of input clocks (K and \bar{K} and C and \bar{C}), memory bandwidth is maximized while simplifying system design by eliminating bus turn arounds.

Port selects for each port enable depth expansion. Port selects allow each port to operate independently.

All synchronous inputs pass through input registers controlled by the K or \bar{K} input clocks. All data outputs pass through output registers controlled by the C or \bar{C} (or K or \bar{K} in a single clock domain) input clocks. Writes are conducted with on-chip synchronous self-timed write circuitry.

Selection Guide

Parameter		333 MHz	300 MHz	250 MHz	200 MHz	Unit
Maximum Operating Frequency		333	300	250	200	MHz
Maximum Operating Current	x8/x9	850	780	680	580	mA
	x18	870	810	700	590	
	x36	1060	980	850	710	

Overview

Figure 1. Logic Block Diagram (CY7C1610KV18)

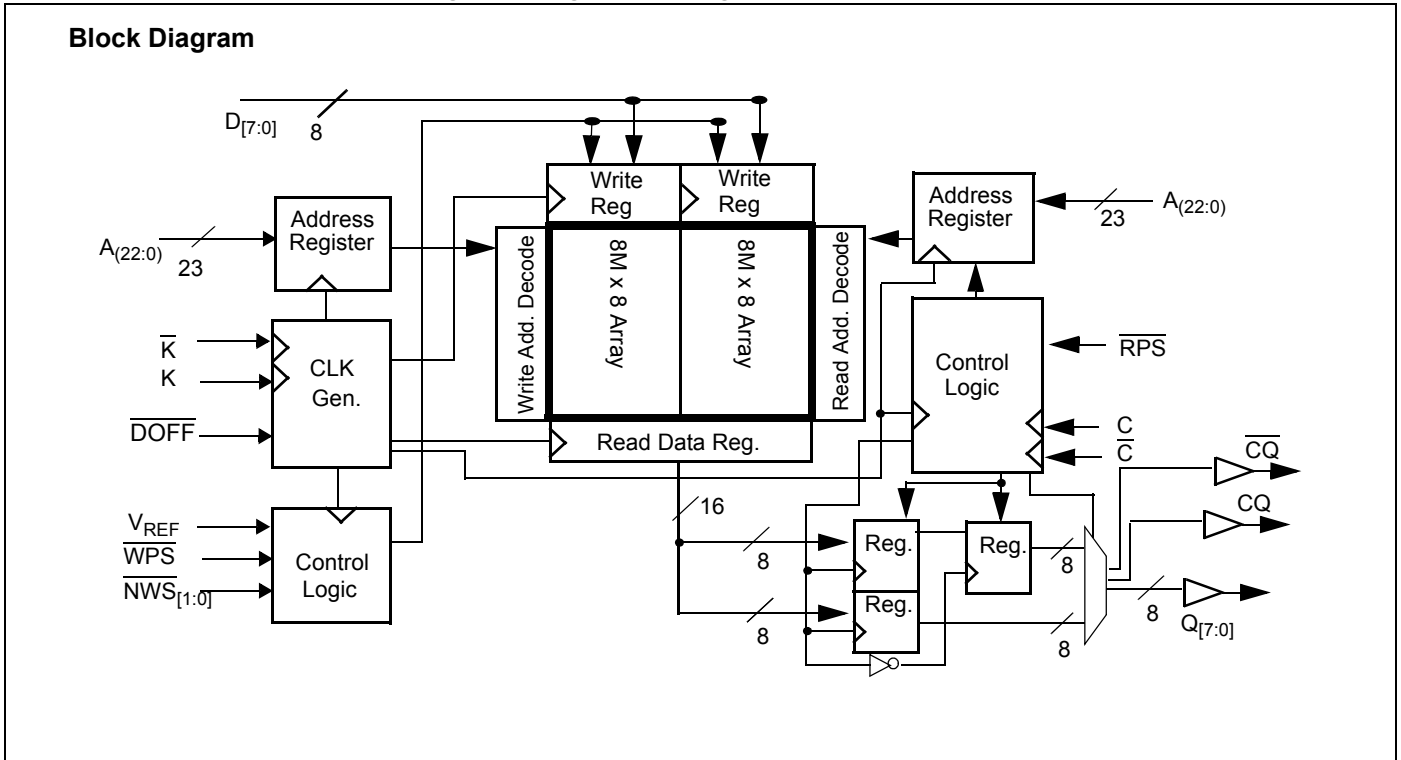

Figure 2. Logic Block Diagram (CY7C1625KV18)

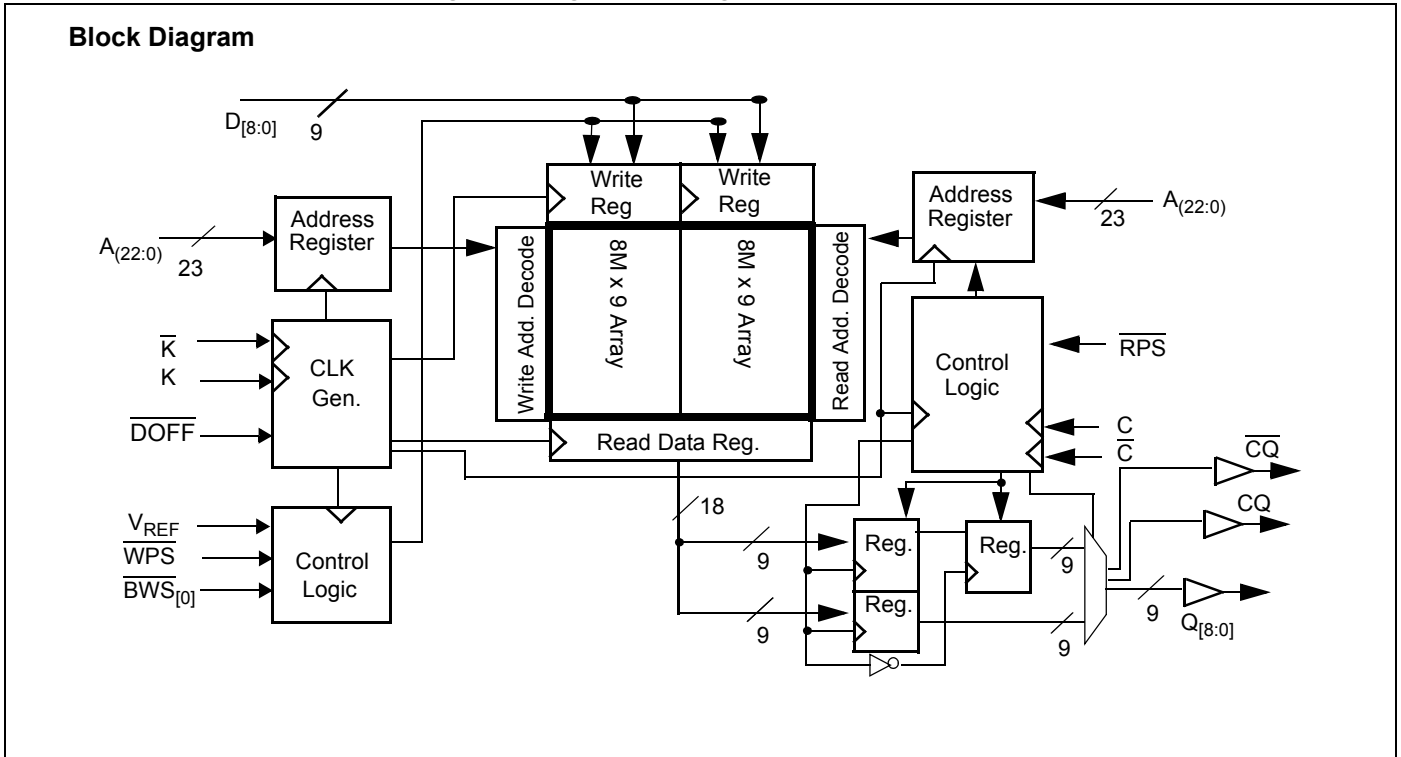

Figure 3. Logic Block Diagram (CY7C1612KV18)

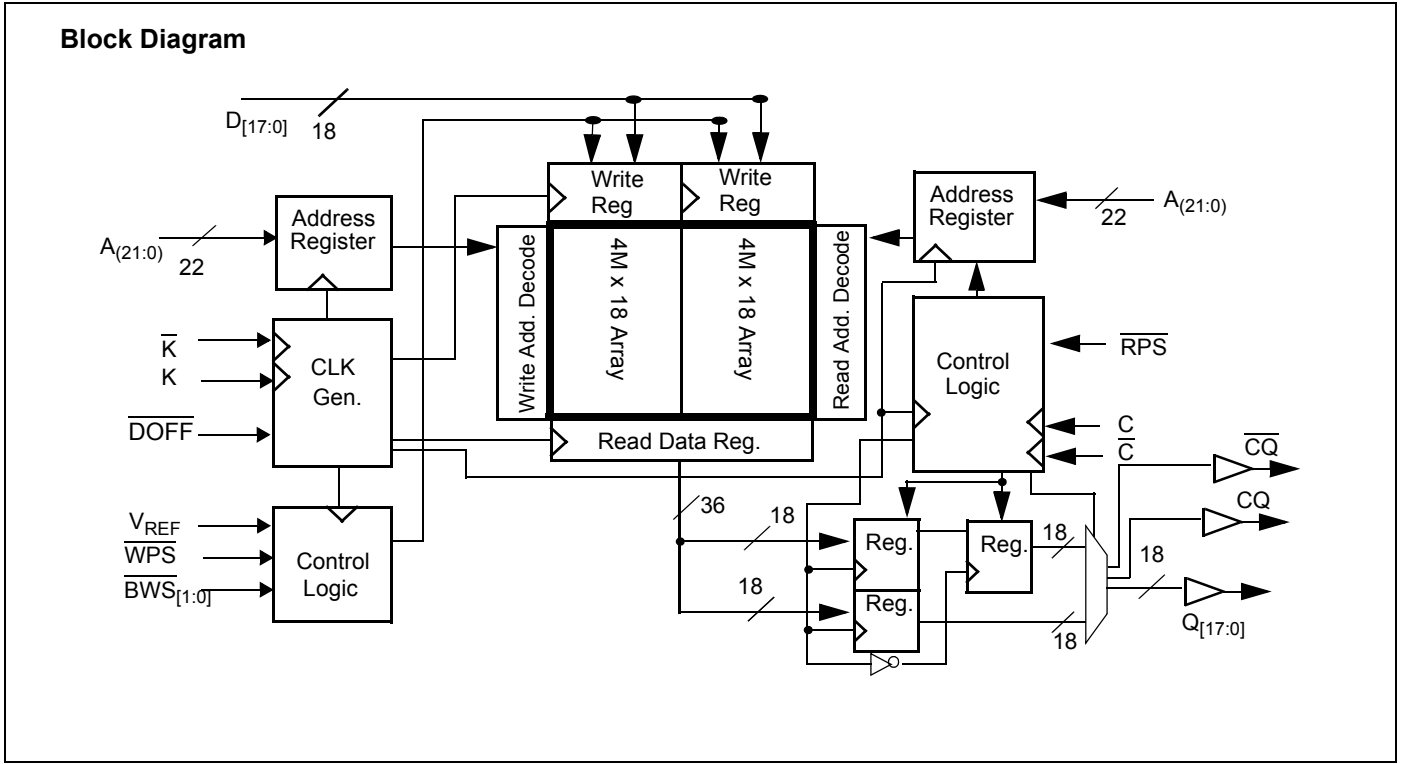
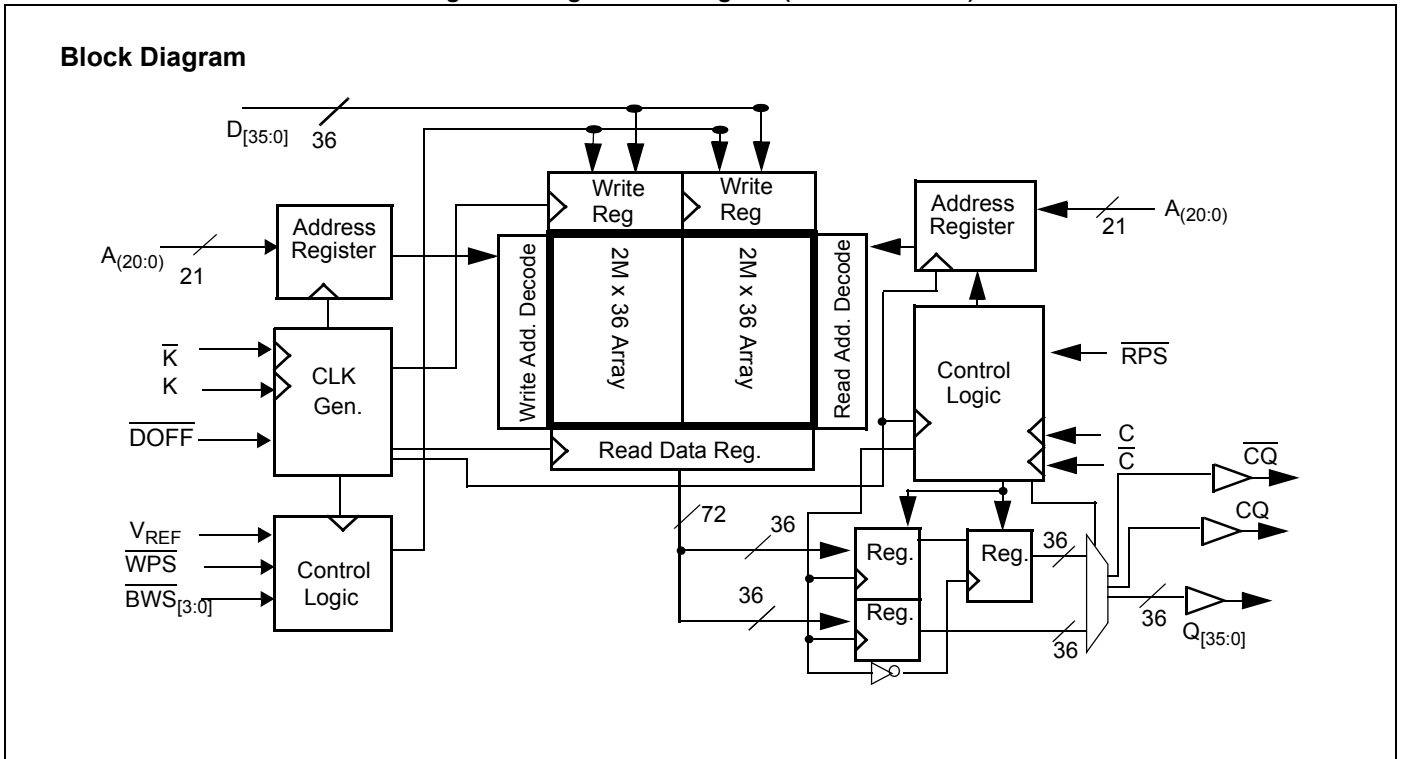

Figure 4. Logic Block Diagram (CY7C1614KV18)



Pin Configurations

165-Ball FBGA (15 x 17 x 1.4 mm) Pinout

Table 1. CY7C1610KV18 (16M x 8)^[1]

	1	2	3	4	5	6	7	8	9	10	11
A	$\overline{\text{CQ}}$	A	A	$\overline{\text{WPS}}$	$\overline{\text{NWS}}_1$	$\overline{\text{K}}$	A	$\overline{\text{RPS}}$	A	A	CQ
B	NC	NC	NC	A	NC/288M	K	$\overline{\text{NWS}}_0$	A	NC	NC	Q3
C	NC	NC	NC	V _{SS}	A	A	A	V _{SS}	NC	NC	D3
D	NC	D4	NC	V _{SS}	V _{SS}	V _{SS}	V _{SS}	V _{SS}	NC	NC	NC
E	NC	NC	Q4	V _{DDQ}	V _{SS}	V _{SS}	V _{SS}	V _{DDQ}	NC	D2	Q2
F	NC	NC	NC	V _{DDQ}	V _{DD}	V _{SS}	V _{DD}	V _{DDQ}	NC	NC	NC
G	NC	D5	Q5	V _{DDQ}	V _{DD}	V _{SS}	V _{DD}	V _{DDQ}	NC	NC	NC
H	$\overline{\text{DOFF}}$	V _{REF}	V _{DDQ}	V _{DDQ}	V _{DD}	V _{SS}	V _{DD}	V _{DDQ}	V _{DDQ}	V _{REF}	ZQ
J	NC	NC	NC	V _{DDQ}	V _{DD}	V _{SS}	V _{DD}	V _{DDQ}	NC	Q1	D1
K	NC	NC	NC	V _{DDQ}	V _{DD}	V _{SS}	V _{DD}	V _{DDQ}	NC	NC	NC
L	NC	Q6	D6	V _{DDQ}	V _{SS}	V _{SS}	V _{SS}	V _{DDQ}	NC	NC	Q0
M	NC	NC	NC	V _{SS}	V _{SS}	V _{SS}	V _{SS}	V _{SS}	NC	NC	D0
N	NC	D7	NC	V _{SS}	A	A	A	V _{SS}	NC	NC	NC
P	NC	NC	Q7	A	A	C	A	A	NC	NC	NC
R	TDO	TCK	A	A	A	$\overline{\text{C}}$	A	A	A	TMS	TDI

Table 2. CY7C1625KV18 (16M x 9)^[1]

	1	2	3	4	5	6	7	8	9	10	11
A	$\overline{\text{CQ}}$	A	A	$\overline{\text{WPS}}$	NC	$\overline{\text{K}}$	A	$\overline{\text{RPS}}$	A	A	CQ
B	NC	NC	NC	A	NC/288M	K	$\overline{\text{BWS}}_0$	A	NC	NC	Q4
C	NC	NC	NC	V _{SS}	A	A	A	V _{SS}	NC	NC	D4
D	NC	D5	NC	V _{SS}	V _{SS}	V _{SS}	V _{SS}	V _{SS}	NC	NC	NC
E	NC	NC	Q5	V _{DDQ}	V _{SS}	V _{SS}	V _{SS}	V _{DDQ}	NC	D3	Q3
F	NC	NC	NC	V _{DDQ}	V _{DD}	V _{SS}	V _{DD}	V _{DDQ}	NC	NC	NC
G	NC	D6	Q6	V _{DDQ}	V _{DD}	V _{SS}	V _{DD}	V _{DDQ}	NC	NC	NC
H	$\overline{\text{DOFF}}$	V _{REF}	V _{DDQ}	V _{DDQ}	V _{DD}	V _{SS}	V _{DD}	V _{DDQ}	V _{DDQ}	V _{REF}	ZQ
J	NC	NC	NC	V _{DDQ}	V _{DD}	V _{SS}	V _{DD}	V _{DDQ}	NC	Q2	D2
K	NC	NC	NC	V _{DDQ}	V _{DD}	V _{SS}	V _{DD}	V _{DDQ}	NC	NC	NC
L	NC	Q7	D7	V _{DDQ}	V _{SS}	V _{SS}	V _{SS}	V _{DDQ}	NC	NC	Q1
M	NC	NC	NC	V _{SS}	V _{SS}	V _{SS}	V _{SS}	V _{SS}	NC	NC	D1
N	NC	D8	NC	V _{SS}	A	A	A	V _{SS}	NC	NC	NC
P	NC	NC	Q8	A	A	C	A	A	NC	D0	Q0
R	TDO	TCK	A	A	A	$\overline{\text{C}}$	A	A	A	TMS	TDI

Note

1. NC/288M is not connected to the die and can be tied to any voltage level.

165-Ball FBGA (15 x 17 x 1.4 mm) Pinout

Table 3. CY7C1612KV18 (8M x 18)^[1]

	1	2	3	4	5	6	7	8	9	10	11
A	$\overline{\text{CQ}}$	A	A	$\overline{\text{WPS}}$	$\overline{\text{BWS}}_1$	$\overline{\text{K}}$	NC/288M	$\overline{\text{RPS}}$	A	A	CQ
B	NC	Q9	D9	A	NC	K	$\overline{\text{BWS}}_0$	A	NC	NC	Q8
C	NC	NC	D10	V_{SS}	A	A	A	V_{SS}	NC	Q7	D8
D	NC	D11	Q10	V_{SS}	V_{SS}	V_{SS}	V_{SS}	V_{SS}	NC	NC	D7
E	NC	NC	Q11	V_{DDQ}	V_{SS}	V_{SS}	V_{SS}	V_{DDQ}	NC	D6	Q6
F	NC	Q12	D12	V_{DDQ}	V_{DD}	V_{SS}	V_{DD}	V_{DDQ}	NC	NC	Q5
G	NC	D13	Q13	V_{DDQ}	V_{DD}	V_{SS}	V_{DD}	V_{DDQ}	NC	NC	D5
H	$\overline{\text{DOFF}}$	V_{REF}	V_{DDQ}	V_{DDQ}	V_{DD}	V_{SS}	V_{DD}	V_{DDQ}	V_{DDQ}	V_{REF}	ZQ
J	NC	NC	D14	V_{DDQ}	V_{DD}	V_{SS}	V_{DD}	V_{DDQ}	NC	Q4	D4
K	NC	NC	Q14	V_{DDQ}	V_{DD}	V_{SS}	V_{DD}	V_{DDQ}	NC	D3	Q3
L	NC	Q15	D15	V_{DDQ}	V_{SS}	V_{SS}	V_{SS}	V_{DDQ}	NC	NC	Q2
M	NC	NC	D16	V_{SS}	V_{SS}	V_{SS}	V_{SS}	V_{SS}	NC	Q1	D2
N	NC	D17	Q16	V_{SS}	A	A	A	V_{SS}	NC	NC	D1
P	NC	NC	Q17	A	A	C	A	A	NC	D0	Q0
R	TDO	TCK	A	A	A	$\overline{\text{C}}$	A	A	A	TMS	TDI

Table 4. CY7C1614KV18 (4M x 36)^[1]

	1	2	3	4	5	6	7	8	9	10	11
A	$\overline{\text{CQ}}$	NC/288M	A	$\overline{\text{WPS}}$	$\overline{\text{BWS}}_2$	$\overline{\text{K}}$	$\overline{\text{BWS}}_1$	$\overline{\text{RPS}}$	A	A	CQ
B	Q27	Q18	D18	A	$\overline{\text{BWS}}_3$	K	$\overline{\text{BWS}}_0$	A	D17	Q17	Q8
C	D27	Q28	D19	V_{SS}	A	A	A	V_{SS}	D16	Q7	D8
D	D28	D20	Q19	V_{SS}	V_{SS}	V_{SS}	V_{SS}	V_{SS}	Q16	D15	D7
E	Q29	D29	Q20	V_{DDQ}	V_{SS}	V_{SS}	V_{SS}	V_{DDQ}	Q15	D6	Q6
F	Q30	Q21	D21	V_{DDQ}	V_{DD}	V_{SS}	V_{DD}	V_{DDQ}	D14	Q14	Q5
G	D30	D22	Q22	V_{DDQ}	V_{DD}	V_{SS}	V_{DD}	V_{DDQ}	Q13	D13	D5
H	$\overline{\text{DOFF}}$	V_{REF}	V_{DDQ}	V_{DDQ}	V_{DD}	V_{SS}	V_{DD}	V_{DDQ}	V_{DDQ}	V_{REF}	ZQ
J	D31	Q31	D23	V_{DDQ}	V_{DD}	V_{SS}	V_{DD}	V_{DDQ}	D12	Q4	D4
K	Q32	D32	Q23	V_{DDQ}	V_{DD}	V_{SS}	V_{DD}	V_{DDQ}	Q12	D3	Q3
L	Q33	Q24	D24	V_{DDQ}	V_{SS}	V_{SS}	V_{SS}	V_{DDQ}	D11	Q11	Q2
M	D33	Q34	D25	V_{SS}	V_{SS}	V_{SS}	V_{SS}	V_{SS}	D10	Q1	D2
N	D34	D26	Q25	V_{SS}	A	A	A	V_{SS}	Q10	D9	D1
P	Q35	D35	Q26	A	A	C	A	A	Q9	D0	Q0
R	TDO	TCK	A	A	A	$\overline{\text{C}}$	A	A	A	TMS	TDI

Ordering Information

Not all of the speed, package and temperature ranges are available. Contact your local sales representative or visit www.cypress.com for actual products offered.

Table 5. Ordering Information

Speed (MHz)	Ordering Code	Package Diagram	Package Type	Operating Range		
333	CY7C1610KV18-333BZC	51-85195	165-Ball Fine Pitch Ball Grid Array (15 x 17 x 1.4 mm)	Commercial		
	CY7C1625KV18-333BZC					
	CY7C1612KV18-333BZC					
	CY7C1614KV18-333BZC					
	CY7C1610KV18-333BZXC	51-85195	165-Ball Fine Pitch Ball Grid Array (15 x 17 x 1.4 mm) Pb-Free			
	CY7C1625KV18-333BZXC					
	CY7C1612KV18-333BZXC					
	CY7C1614KV18-333BZXC					
	333	CY7C1610KV18-333BZI	51-85195		165-Ball Fine Pitch Ball Grid Array (15 x 17 x 1.4 mm)	Industrial
		CY7C1625KV18-333BZI				
		CY7C1612KV18-333BZI				
		CY7C1614KV18-333BZI				
CY7C1610KV18-333BZXI		51-85195	165-Ball Fine Pitch Ball Grid Array (15 x 17 x 1.4 mm) Pb-Free			
CY7C1625KV18-333BZXI						
CY7C1612KV18-300BZXI						
CY7C1614KV18-333BZXI						
300	CY7C1610KV18-300BZC	51-85195	165-Ball Fine Pitch Ball Grid Array (15 x 17 x 1.4 mm)	Commercial		
	CY7C1625KV18-300BZC					
	CY7C1612KV18-300BZC					
	CY7C1614KV18-300BZC					
	CY7C1610KV18-300BZXC	51-85195	165-Ball Fine Pitch Ball Grid Array (15 x 17 x 1.4 mm) Pb-Free			
	CY7C1625KV18-300BZXC					
	CY7C1612KV18-300BZXC					
	CY7C1614KV18-300BZXC					
	300	CY7C1610KV18-300BZI	51-85195		165-Ball Fine Pitch Ball Grid Array (15 x 17 x 1.4 mm)	Industrial
		CY7C1625KV18-300BZI				
		CY7C1612KV18-300BZI				
		CY7C1614KV18-300BZI				
CY7C1610KV18-300BZXI		51-85195	165-Ball Fine Pitch Ball Grid Array (15 x 17 x 1.4 mm) Pb-Free			
CY7C1625KV18-300BZXI						
CY7C1612KV18-300BZXI						
CY7C1614KV18-300BZXI						

Table 5. Ordering Information (continued)

Speed (MHz)	Ordering Code	Package Diagram	Package Type	Operating Range
250	CY7C1610KV18-250BZC	51-85195	165-Ball Fine Pitch Ball Grid Array (15 x 17 x 1.4 mm)	Commercial
	CY7C1625KV18-250BZC			
	CY7C1612KV18-250BZC			
	CY7C1614KV18-250BZC			
	CY7C1610KV18-250BZXC	51-85195	165-Ball Fine Pitch Ball Grid Array (15 x 17 x 1.4 mm) Pb-Free	
	CY7C1625KV18-250BZXC			
	CY7C1612KV18-250BZXC			
	CY7C1614KV18-250BZXC			
	CY7C1610KV18-250BZI	51-85195	165-Ball Fine Pitch Ball Grid Array (15 x 17 x 1.4 mm)	Industrial
	CY7C1625KV18-250BZI			
	CY7C1612KV18-250BZI			
	CY7C1614KV18-250BZI			
	CY7C1610KV18-250BZXI	51-85195	165-Ball Fine Pitch Ball Grid Array (15 x 17 x 1.4 mm) Pb-Free	
	CY7C1625KV18-250BZXI			
	CY7C1612KV18-250BZXI			
	CY7C1614KV18-250BZXI			
200	CY7C1610KV18-200BZC	51-85195	165-Ball Fine Pitch Ball Grid Array (15 x 17 x 1.4 mm)	Commercial
	CY7C1625KV18-200BZC			
	CY7C1612KV18-200BZC			
	CY7C1614KV18-200BZC			
	CY7C1610KV18-200BZXC	51-85195	165-Ball Fine Pitch Ball Grid Array (15 x 17 x 1.4 mm) Pb-Free	
	CY7C1625KV18-200BZXC			
	CY7C1612KV18-200BZXC			
	CY7C1614KV18-200BZXC			
	CY7C1610KV18-200BZI	51-85195	165-Ball Fine Pitch Ball Grid Array (15 x 17 x 1.4 mm)	Industrial
	CY7C1625KV18-200BZI			
	CY7C1612KV18-200BZI			
	CY7C1614KV18-200BZI			
	CY7C1610KV18-200BZXI	51-85195	165-Ball Fine Pitch Ball Grid Array (15 x 17 x 1.4 mm) Pb-Free	
	CY7C1625KV18-200BZXI			
	CY7C1612KV18-200BZXI			
	CY7C1614KV18-200BZXI			



Document History Page

Document Title: CY7C1610KV18/CY7C1625KV18/CY7C1612KV18/CY7C1614KV18 144-Mbit QDR™-II SRAM 2-Word Burst Architecture				
Document Number: 001-16238				
REV.	ECN No.	Issue Date	Orig. of Change	Description of Change
**	1184523	See ECN	VKN	New Data Sheet

© Cypress Semiconductor Corporation, 2007. The information contained herein is subject to change without notice. Cypress Semiconductor Corporation assumes no responsibility for the use of any circuitry other than circuitry embodied in a Cypress product. Nor does it convey or imply any license under patent or other rights. Cypress products are not warranted nor intended to be used for medical, life support, life saving, critical control or safety applications, unless pursuant to an express written agreement with Cypress. Furthermore, Cypress does not authorize its products for use as critical components in life-support systems where a malfunction or failure may reasonably be expected to result in significant injury to the user. The inclusion of Cypress products in life-support systems application implies that the manufacturer assumes all risk of such use and in doing so indemnifies Cypress against all charges.

Any Source Code (software and/or firmware) is owned by Cypress Semiconductor Corporation (Cypress) and is protected by and subject to worldwide patent protection (United States and foreign), United States copyright laws and international treaty provisions. Cypress hereby grants to licensee a personal, non-exclusive, non-transferable license to copy, use, modify, create derivative works of, and compile the Cypress Source Code and derivative works for the sole purpose of creating custom software and or firmware in support of licensee product to be used only in conjunction with a Cypress integrated circuit as specified in the applicable agreement. Any reproduction, modification, translation, compilation, or representation of this Source Code except as specified above is prohibited without the express written permission of Cypress.

Disclaimer: CYPRESS MAKES NO WARRANTY OF ANY KIND, EXPRESS OR IMPLIED, WITH REGARD TO THIS MATERIAL, INCLUDING, BUT NOT LIMITED TO, THE IMPLIED WARRANTIES OF MERCHANTABILITY AND FITNESS FOR A PARTICULAR PURPOSE. Cypress reserves the right to make changes without further notice to the materials described herein. Cypress does not assume any liability arising out of the application or use of any product or circuit described herein. Cypress does not authorize its products for use as critical components in life-support systems where a malfunction or failure may reasonably be expected to result in significant injury to the user. The inclusion of Cypress' product in a life-support systems application implies that the manufacturer assumes all risk of such use and in doing so indemnifies Cypress against all charges.

Use may be limited by and subject to the applicable Cypress software license agreement.