

2-Mbit (64K x 36) Pipelined Sync SRAM

Features

- Registered inputs and outputs for pipelined operation
- 64K × 36 common I/O architecture
- 3.3V core power supply
- 3.3V/2.5V I/O operation
- Fast clock-to-output times
— 3.5 ns (166-MHz device)
- Provide high-performance 3-1-1 access rate
- User-selectable burst counter supporting Intel® Pentium® interleaved or linear burst sequences
- Separate processor and controller address strobes
- Synchronous self-timed writes
- Asynchronous output enable
- Offered in JEDEC-standard lead-free 100-pin TQFP package
- “ZZ” Sleep Mode Option

Functional Description^[1]

The CY7C1346H SRAM integrates 64K x 36 SRAM cells with advanced synchronous peripheral circuitry and a two-bit counter for internal burst operation. All synchronous inputs are gated by registers controlled by a positive-edge-triggered Clock Input (CLK). The synchronous inputs include all addresses, all data inputs, address-pipelining Chip Enable (\overline{CE}_1), depth-expansion Chip Enables (\overline{CE}_2 and \overline{CE}_3), Burst Control inputs (\overline{ADSC} , \overline{ADSP} , and \overline{ADV}), Write Enables ($\overline{BW}_{[A,D]}$, and \overline{BWE}), and Global Write (\overline{GW}). Asynchronous inputs include the Output Enable (\overline{OE}) and the ZZ pin.

Addresses and chip enables are registered at rising edge of clock when either Address Strobe Processor (\overline{ADSP}) or Address Strobe Controller (\overline{ADSC}) are active. Subsequent burst addresses can be internally generated as controlled by the Advance pin (\overline{ADV}).

Address, data inputs, and write controls are registered on-chip to initiate a self-timed Write cycle. This part supports Byte Write operations (see Pin Descriptions and Truth Table for further details). Write cycles can be one to four bytes wide as controlled by the Byte Write control inputs. \overline{GW} when active LOW causes all bytes to be written.

The CY7C1346H operates from a +3.3V core power supply while all outputs also operate with either a +3.3V/2.5V supply. All inputs and outputs are JEDEC-standard JESD8-5-compatible.

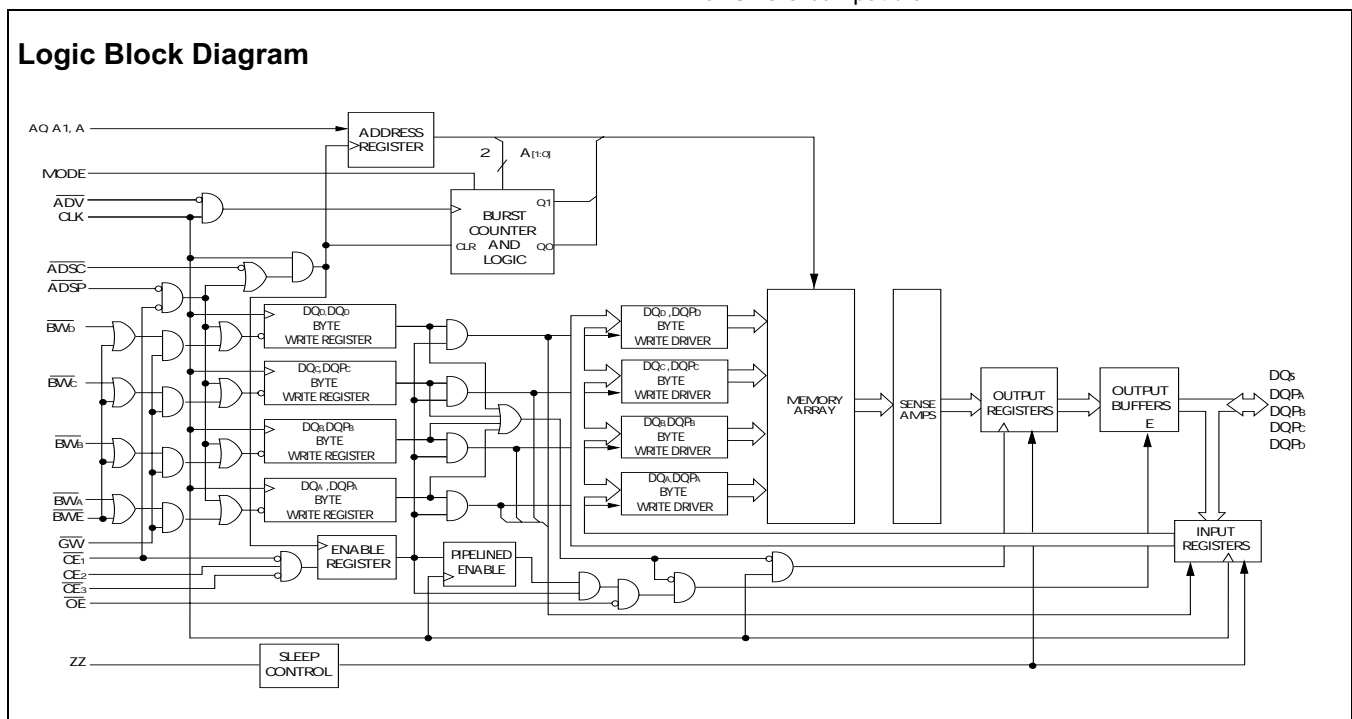

Note:

1. For best-practices recommendations, please refer to the Cypress application note *System Design Guidelines* on www.cypress.com.

Selection Guide

| | 166 MHz | Unit |
|------------------------------|---------|------|
| Maximum Access Time | 3.5 | ns |
| Maximum Operating Current | 240 | mA |
| Maximum CMOS Standby Current | 40 | mA |

Pin Configuration

100-pin TQFP Pinout

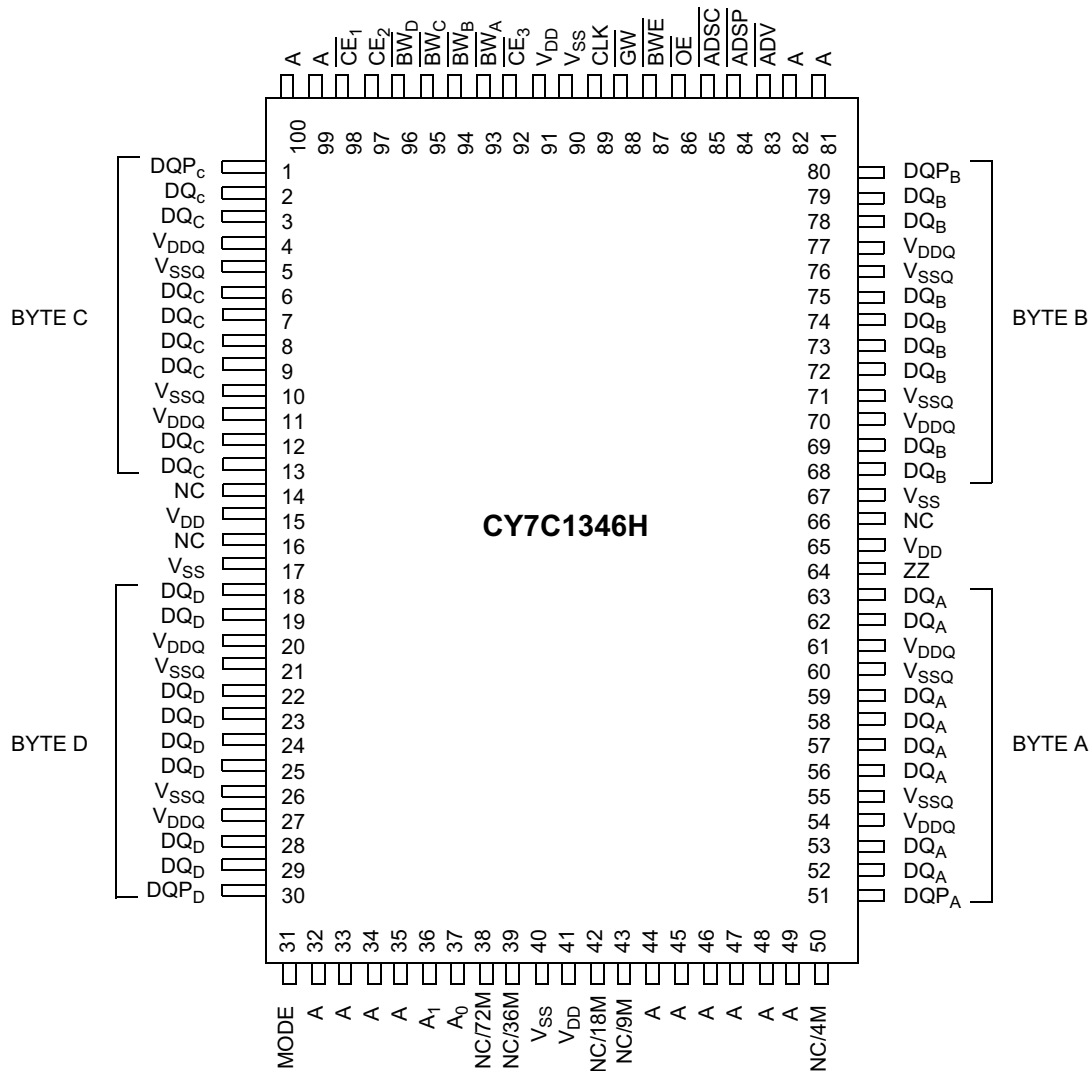

Pin Definitions

| Name | I/O | Description |
|--|--------------------|--|
| A ₀ , A ₁ , A | Input-Synchronous | Address Inputs used to select one of the 64K address locations. Sampled at the rising edge of the CLK if ADSP or ADSC is active LOW, and \overline{CE}_1 , CE ₂ , and \overline{CE}_3 are sampled active. A ₁ , A ₀ feed the 2-bit counter. |
| $\overline{BW}_A, \overline{BW}_B$ $\overline{BW}_C, \overline{BW}_D$ | Input-Synchronous | Byte Write Select Inputs, active LOW. Qualified with \overline{BWE} to conduct Byte Writes to the SRAM. Sampled on the rising edge of CLK. |
| \overline{GW} | Input-Synchronous | Global Write Enable Input, active LOW. When asserted LOW on the rising edge of CLK, a global Write is conducted (ALL bytes are written, regardless of the values on $BW_{[A:D]}$ and \overline{BWE}). |
| \overline{BWE} | Input-Synchronous | Byte Write Enable Input, active LOW. Sampled on the rising edge of CLK. This signal must be asserted LOW to conduct a Byte Write. |
| CLK | Input-Clock | Clock Input. Used to capture all synchronous inputs to the device. Also used to increment the burst counter when ADV is asserted LOW, during a burst operation. |
| \overline{CE}_1 | Input-Synchronous | Chip Enable 1 Input, active LOW. Sampled on the rising edge of CLK. Used in conjunction with CE ₂ and \overline{CE}_3 to select/deselect the device. ADSP is ignored if \overline{CE}_1 is HIGH. \overline{CE}_1 is sampled only when a new external address is loaded. |
| CE ₂ | Input-Synchronous | Chip Enable 2 Input, active HIGH. Sampled on the rising edge of CLK. Used in conjunction with CE ₁ and CE ₃ to select/deselect the device. CE ₂ is sampled only when a new external address is loaded. |
| \overline{CE}_3 | Input-Synchronous | Chip Enable 3 Input, active LOW. Sampled on the rising edge of CLK. Used in conjunction with CE ₁ and CE ₂ to select/deselect the device. \overline{CE}_3 is sampled only when a new external address is loaded. |
| \overline{OE} | Input-Asynchronous | Output Enable, asynchronous input, active LOW. Controls the direction of the I/O pins. When LOW, the I/O pins behave as outputs. When deasserted HIGH, I/O pins are tri-stated, and act as input data pins. \overline{OE} is masked during the first clock of a Read cycle when emerging from a deselected state. |
| ADV | Input-Synchronous | Advance Input signal, sampled on the rising edge of CLK, active LOW. When asserted, it automatically increments the address in a burst cycle. |
| ADSP | Input-Synchronous | Address Strobe from Processor, sampled on the rising edge of CLK, active LOW. When asserted LOW, A is captured in the address registers. A ₁ , A ₀ are also loaded into the burst counter. When ADSP and ADSC are both asserted, only ADSP is recognized. ADSP is ignored when \overline{CE}_1 is deasserted HIGH. |
| ADSC | Input-Synchronous | Address Strobe from Controller, sampled on the rising edge of CLK, active LOW. When asserted LOW, A is captured in the address registers. A ₁ , A ₀ are also loaded into the burst counter. When ADSP and ADSC are both asserted, only ADSP is recognized. |
| ZZ | Input-Asynchronous | ZZ "Sleep" Input, active HIGH. This input, when HIGH places the device in a non-time-critical "sleep" condition with data integrity preserved. For normal operation, this pin has to be LOW or left floating. ZZ pin has an internal pull-down. |
| DQ _A , DQ _B DQ _C , DQ _D , DQP _A , DQP _B DQP _C , DQP | I/O-Synchronous | Bidirectional Data I/O lines. As inputs, they feed into an on-chip data register that is triggered by the rising edge of CLK. As outputs, they deliver the data contained in the memory location specified by "A" during the previous clock rise of the Read cycle. The direction of the pins is controlled by \overline{OE} . When \overline{OE} is asserted LOW, the pins behave as outputs. When HIGH, DQs and DQPs are placed in a tri-state condition. |
| V _{DD} | Power Supply | Power supply inputs to the core of the device. |
| V _{SS} | Ground | Ground for the core of the device. |

Pin Definitions (continued)

| Name | I/O | Description |
|------------------|------------------|---|
| V _{DDQ} | I/O Power Supply | Power supply for the I/O circuitry. |
| V _{SSQ} | I/O Ground | Ground for the I/O circuitry. |
| MODE | Input-Static | Selects Burst Order. When tied to GND selects linear burst sequence. When tied to V _{DD} or left floating selects interleaved burst sequence. This is a strap pin and should remain static during device operation. Mode Pin has an internal pull-up. |
| NC | | No Connects. Not internally connected to the die. 4M, 9M, 18M, 72M, 144M, 288M, 576M and 1G are address expansion pins and are not internally connected to the die. |

Functional Overview

All synchronous inputs pass through input registers controlled by the rising edge of the clock. All data outputs pass through output registers controlled by the rising edge of the clock.

The CY7C1346H supports secondary cache in systems utilizing either a linear or interleaved burst sequence. The interleaved burst order supports Pentium and i486™ processors. The linear burst sequence is suited for processors that utilize a linear burst sequence. The burst order is user selectable, and is determined by sampling the MODE input. Accesses can be initiated with either the Processor Address Strobe (ADSP) or the Controller Address Strobe (ADSC). Address advancement through the burst sequence is controlled by the ADV input. A two-bit on-chip wraparound burst counter captures the first address in a burst sequence and automatically increments the address for the rest of the burst access.

Byte Write operations are qualified with the Byte Write Enable (BWE) and Byte Write Select (BW_[A:D]) inputs. A Global Write Enable (GW) overrides all Byte Write inputs and writes data to all four bytes. All writes are simplified with on-chip synchronous self-timed Write circuitry.

Three synchronous Chip Selects (\overline{CE}_1 , CE₂, \overline{CE}_3) and an asynchronous Output Enable (OE) provide for easy bank selection and output tri-state control. ADSP is ignored if CE₁ is HIGH.

Single Read Accesses

This access is initiated when the following conditions are satisfied at clock rise: (1) ADSP or ADSC is asserted LOW, (2) CE₁, CE₂, CE₃ are all asserted active, and (3) the Write signals (GW, BWE) are all deasserted HIGH. ADSP is ignored if CE₁ is HIGH. The address presented to the address inputs (A) is stored into the address advancement logic and the address register while being presented to the memory array. The corresponding data is allowed to propagate to the input of the output registers. At the rising edge of the next clock the data is allowed to propagate through the output register and onto the data bus within t_{CO} if OE is active LOW. The only exception occurs when the SRAM is emerging from a deselected state to a selected state, its outputs are always tri-stated during the first cycle of the access. After the first cycle of the access, the outputs are controlled by the OE signal. Consecutive single Read cycles are supported. Once the SRAM is deselected at clock rise by the chip select and either ADSP or ADSC signals, its output will tri-state immediately.

Single Write Accesses Initiated by ADSP

This access is initiated when both of the following conditions are satisfied at clock rise: (1) ADSP is asserted LOW, and (2) CE₁, CE₂, CE₃ are all asserted active. The address presented to A is loaded into the address register and the address advancement logic while being delivered to the RAM array. The Write signals (GW, BWE, and BW_[A:D]) and ADV inputs are ignored during this first cycle.

ADSP-triggered Write accesses require two clock cycles to complete. If GW is asserted LOW on the second clock rise, the data presented to the DQ inputs is written into the corresponding address location in the memory array. If GW is HIGH, then the Write operation is controlled by BWE and BW_[A:D] signals. The CY7C1346H provides Byte Write capability that is described in the Write Cycle Descriptions table. Asserting the Byte Write Enable input (BWE) with the selected Byte Write (BW_[A:D]) input, will selectively write to only the desired bytes. Bytes not selected during a Byte Write operation will remain unaltered. A synchronous self-timed Write mechanism has been provided to simplify the Write operations.

Because the CY7C1346H is a common I/O device, the Output Enable (OE) must be deasserted HIGH before presenting data to the DQ inputs. Doing so will tri-state the output drivers. As a safety precaution, DQ are automatically tri-stated whenever a Write cycle is detected, regardless of the state of OE.

Single Write Accesses Initiated by ADSC

ADSC Write accesses are initiated when the following conditions are satisfied: (1) ADSC is asserted LOW, (2) ADSP is deasserted HIGH, (3) CE₁, CE₂, CE₃ are all asserted active, and (4) the appropriate combination of the Write inputs (GW, BWE, and BW_[A:D]) are asserted active to conduct a Write to the desired byte(s). ADSC-triggered Write accesses require a single clock cycle to complete. The address presented to A is loaded into the address register and the address advancement logic while being delivered to the memory array. The ADV input is ignored during this cycle. If a global Write is conducted, the data presented to DQ is written into the corresponding address location in the memory core. If a Byte Write is conducted, only the selected bytes are written. Bytes not selected during a Byte Write operation will remain unaltered. A synchronous self-timed Write mechanism has been provided to simplify the Write operations.

Because the CY7C1346H is a common I/O device, the Output Enable (OE) must be deserted HIGH before presenting data to the DQ inputs. Doing so will tri-state the output drivers. As a safety precaution, DQs are automatically tri-stated whenever a Write cycle is detected, regardless of the state of OE.

Burst Sequences

The CY7C1346H provides a two-bit wraparound counter, fed by A_1, A_0 , that implements either an interleaved or linear burst sequence. The interleaved burst sequence is designed specifically to support Intel Pentium applications. The linear burst sequence is designed to support processors that follow a linear burst sequence. The burst sequence is user selectable through the MODE input.

Asserting \overline{ADV} LOW at clock rise will automatically increment the burst counter to the next address in the burst sequence. Both Read and Write burst operations are supported.

Sleep Mode

The ZZ input pin is an asynchronous input. Asserting ZZ places the SRAM in a power conservation “sleep” mode. Two clock cycles are required to enter into or exit from this “sleep” mode. While in this mode, data integrity is guaranteed. Accesses pending when entering the “sleep” mode are not considered valid nor is the completion of the operation guaranteed. The device must be deselected prior to entering the “sleep” mode. $\overline{CE}_1, \overline{CE}_2, \overline{CE}_3, \overline{ADSP}$, and \overline{ADSC} must remain inactive for the duration of t_{ZZREC} after the ZZ input returns LOW.

ZZ Mode Electrical Characteristics

| Parameter | Description | Test Conditions | Min. | Max. | Unit |
|-------------|-----------------------------------|---------------------------|------------|------------|------|
| I_{DDZZ} | Sleep mode standby current | $ZZ \geq V_{DD} - 0.2V$ | | 40 | mA |
| t_{ZZS} | Device operation to ZZ | $ZZ \geq V_{DD} - 0.2V$ | | $2t_{CYC}$ | ns |
| t_{ZZREC} | ZZ recovery time | $ZZ \leq 0.2V$ | $2t_{CYC}$ | | ns |
| t_{ZZI} | ZZ Active to sleep current | This parameter is sampled | | $2t_{CYC}$ | ns |
| t_{RZZI} | ZZ Inactive to exit sleep current | This parameter is sampled | 0 | | ns |

Interleaved Burst Address Table (MODE = Floating or V_{DD})

| First Address A_1, A_0 | Second Address A_1, A_0 | Third Address A_1, A_0 | Fourth Address A_1, A_0 |
|-----------------------------|------------------------------|-----------------------------|------------------------------|
| 00 | 01 | 10 | 11 |
| 01 | 00 | 11 | 10 |
| 10 | 11 | 00 | 01 |
| 11 | 10 | 01 | 00 |

Linear Burst Address Table (MODE = GND)

| First Address A_1, A_0 | Second Address A_1, A_0 | Third Address A_1, A_0 | Fourth Address A_1, A_0 |
|-----------------------------|------------------------------|-----------------------------|------------------------------|
| 00 | 01 | 10 | 11 |
| 01 | 10 | 11 | 00 |
| 10 | 11 | 00 | 01 |
| 11 | 00 | 01 | 10 |

Truth Table [2, 3, 4, 5, 6, 7]

| Next Cycle | Add. Used | \overline{CE}_1 | CE_2 | \overline{CE}_3 | ZZ | \overline{ADSP} | \overline{ADSC} | \overline{ADV} | \overline{WRITE} | \overline{OE} | CLK | DQ |
|-----------------------------|-----------|-------------------|--------|-------------------|----|-------------------|-------------------|------------------|--------------------|-----------------|-----|-----------|
| Deselect Cycle, Power-down | None | H | X | X | L | X | L | X | X | X | L-H | Tri-State |
| Deselect Cycle, Power-down | None | L | L | X | L | L | X | X | X | X | L-H | Tri-State |
| Deselect Cycle, Power-down | None | L | X | H | L | L | X | X | X | X | L-H | Tri-State |
| Deselect Cycle, Power-down | None | L | L | X | L | H | L | X | X | X | L-H | Tri-State |
| Deselect Cycle, Power-down | None | L | X | H | L | H | L | X | X | X | L-H | Tri-State |
| Sleep Mode, Power-down | None | X | X | X | H | X | X | X | X | X | X | Tri-State |
| READ Cycle, Begin Burst | External | L | H | L | L | L | X | X | X | L | L-H | Q |
| READ Cycle, Begin Burst | External | L | H | L | L | L | X | X | X | H | L-H | Tri-State |
| WRITE Cycle, Begin Burst | External | L | H | L | L | H | L | X | L | X | L-H | D |
| READ Cycle, Begin Burst | External | L | H | L | L | H | L | X | H | L | L-H | Q |
| READ Cycle, Begin Burst | External | L | H | L | L | H | L | X | H | H | L-H | Tri-State |
| READ Cycle, Continue Burst | Next | X | X | X | L | H | H | L | H | L | L-H | Q |
| READ Cycle, Continue Burst | Next | X | X | X | L | H | H | L | H | H | L-H | Tri-State |
| READ Cycle, Continue Burst | Next | H | X | X | L | X | H | L | H | L | L-H | Q |
| READ Cycle, Continue Burst | Next | H | X | X | L | X | H | L | H | H | L-H | Tri-State |
| WRITE Cycle, Continue Burst | Next | X | X | X | L | H | H | L | L | X | L-H | D |
| WRITE Cycle, Continue Burst | Next | H | X | X | L | X | H | L | L | X | L-H | D |
| READ Cycle, Suspend Burst | Current | X | X | X | L | H | H | H | H | L | L-H | Q |
| READ Cycle, Suspend Burst | Current | X | X | X | L | H | H | H | H | H | L-H | Tri-State |
| READ Cycle, Suspend Burst | Current | H | X | X | L | X | H | H | H | L | L-H | Q |
| READ Cycle, Suspend Burst | Current | H | X | X | L | X | H | H | H | H | L-H | Tri-State |

Notes:

- X = "Don't Care." H = Logic HIGH, L = Logic LOW.
- $\overline{WRITE} = L$ when any one or more Byte Write Enable signals ($\overline{BW}_A, \overline{BW}_B, \overline{BW}_C, \overline{BW}_D$) and $\overline{BWE} = L$ or $\overline{GW} = L$. $\overline{WRITE} = H$ when all Byte Write Enable signals ($\overline{BW}_A, \overline{BW}_B, \overline{BW}_C, \overline{BW}_D$), \overline{BWE} , $\overline{GW} = H$.
- The DQ pins are controlled by the current cycle and the \overline{OE} signal. \overline{OE} is asynchronous and is not sampled with the clock.
- \overline{CE}_1 , \overline{CE}_2 , and \overline{CE}_3 are available only in the TQFP package.
- The SRAM always initiates a read cycle when \overline{ADSP} is asserted, regardless of the state of \overline{GW} , \overline{BWE} , or $\overline{BW}_{[A,D]}$. Writes may occur only on subsequent clocks after the \overline{ADSP} or with the assertion of \overline{ADSC} . As a result, \overline{OE} must be driven HIGH prior to the start of the Write cycle to allow the outputs to Tri-State. \overline{OE} is a don't care for the remainder of the Write cycle.
- \overline{OE} is asynchronous and is not sampled with the clock rise. It is masked internally during Write cycles. During a Read cycle all data bits are Tri-State when \overline{OE} is inactive or when the device is deselected, and all data bits behave as output when \overline{OE} is active (LOW).

Truth Table (continued)^[2, 3, 4, 5, 6, 7]

| Next Cycle | Add. Used | \overline{CE}_1 | CE_2 | \overline{CE}_3 | ZZ | \overline{ADSP} | \overline{ADSC} | \overline{ADV} | \overline{WRITE} | \overline{OE} | CLK | DQ |
|----------------------------|-----------|-------------------|--------|-------------------|----|-------------------|-------------------|------------------|--------------------|-----------------|-----|----|
| WRITE Cycle, Suspend Burst | Current | X | X | X | L | H | H | H | L | X | L-H | D |
| WRITE Cycle, Suspend Burst | Current | H | X | X | L | X | H | H | L | X | L-H | D |

Truth Table for Read/Write^[2, 3]

| Function | \overline{GW} | \overline{BWE} | \overline{BW}_D | \overline{BW}_C | \overline{BW}_B | \overline{BW}_A |
|--|-----------------|------------------|-------------------|-------------------|-------------------|-------------------|
| Read | H | H | X | X | X | X |
| Read | H | L | H | H | H | H |
| Write Byte A – (DQ _A and DQP _A) | H | L | H | H | H | L |
| Write Byte B – (DQ _B and DQP _B) | H | L | H | H | L | H |
| Write Bytes B, A | H | L | H | H | L | L |
| Write Byte C – (DQ _C and DQP _C) | H | L | H | L | H | H |
| Write Bytes C, A | H | L | H | L | H | L |
| Write Bytes C, B | H | L | H | L | L | H |
| Write Bytes C, B, A | H | L | H | L | L | L |
| Write Byte D – (DQ _D and DQP _D) | H | L | L | H | H | H |
| Write Bytes D, A | H | L | L | H | H | L |
| Write Bytes D, B | H | L | L | H | L | H |
| Write Bytes D, B, A | H | L | L | H | L | L |
| Write Bytes D, C | H | L | L | L | H | H |
| Write Bytes D, C, A | H | L | L | L | H | L |
| Write Bytes D, C, B | H | L | L | L | L | H |
| Write All Bytes | H | L | L | L | L | L |
| Write All Bytes | L | X | X | X | X | X |

Maximum Ratings

(Above which the useful life may be impaired. For user guidelines, not tested.)

Storage Temperature -65°C to +150°C
 Ambient Temperature with Power Applied..... -55°C to +125°C
 Supply Voltage on V_{DD} Relative to GND..... -0.5V to +4.6V
 Supply Voltage on V_{DDQ} Relative to GND -0.5V to +V_{DD}
 DC Voltage Applied to Outputs in Tri-State..... -0.5V to V_{DDQ} + 0.5V

DC Input Voltage -0.5V to V_{DD} + 0.5V
 Current into Outputs (LOW)..... 20 mA
 Static Discharge Voltage..... >2001V (per MIL-STD-883, Method 3015)
 Latch-up Current..... >200 mA

Operating Range

| Range | Ambient Temperature | V _{DD} | V _{DDQ} |
|------------|---------------------|-----------------|-----------------------------|
| Commercial | 0°C to +70°C | 3.3V -5%/+10% | 2.5V -5% to V _{DD} |
| Industrial | -40°C to +85°C | | |

Electrical Characteristics Over the Operating Range [8, 9]

| Parameter | Description | Test Conditions | Min. | Max. | Unit |
|-------------------------|---|--|-------|------------------------|------|
| V _{DD} | Power Supply Voltage | | 3.135 | 3.6 | V |
| V _{DDQ} | I/O Supply Voltage | for 3.3V I/O | 3.135 | V _{DD} | V |
| | | for 2.5V I/O | 2.375 | 2.625 | |
| V _{OH} | Output HIGH Voltage | for 3.3V I/O, I _{OH} = -4.0 mA | 2.4 | | V |
| | | for 2.5V I/O, I _{OH} = -1.0 mA | 2.0 | | |
| V _{OL} | Output LOW Voltage | for 3.3V I/O, I _{OL} = 8.0 mA | | 0.4 | V |
| | | for 2.5V I/O, I _{OL} = 1.0 mA | | 0.4 | |
| V _{IH} | Input HIGH Voltage ^[8] | for 3.3V I/O | 2.0 | V _{DD} + 0.3V | V |
| | | for 2.5V I/O | 1.7 | V _{DD} + 0.3V | V |
| V _{IL} | Input LOW Voltage ^[8] | for 3.3V I/O | -0.3 | 0.8 | V |
| | | for 2.5V I/O | -0.3 | 0.7 | V |
| I _X | Input Leakage Current except ZZ and MODE | GND ≤ V _I ≤ V _{DDQ} | -5 | 5 | μA |
| | Input Current of MODE | Input = V _{SS} | -30 | | μA |
| | | Input = V _{DD} | | 5 | μA |
| | Input Current of ZZ | Input = V _{SS} | -5 | | μA |
| Input = V _{DD} | | | 30 | μA | |
| I _{OZ} | Output Leakage Current | GND ≤ V _I ≤ V _{DDQ} , Output Disabled | -5 | 5 | μA |
| I _{DD} | V _{DD} Operating Supply Current | V _{DD} = Max., I _{OUT} = 0 mA, f = f _{MAX} = 1/t _{CYC} | | 240 | mA |
| I _{SB1} | Automatic CS Power-down Current—TTL Inputs | V _{DD} = Max, Device Deselected, V _{IN} ≥ V _{IH} or V _{IN} ≤ V _{IL} , f = f _{MAX} = 1/t _{CYC} | | 100 | mA |
| I _{SB2} | Automatic CS Power-down Current—CMOS Inputs | V _{DD} = Max, Device Deselected, V _{IN} ≤ 0.3V or V _{IN} ≥ V _{DDQ} - 0.3V, f = 0 | | 40 | mA |
| I _{SB3} | Automatic CS Power-down Current—CMOS Inputs | V _{DD} = Max, Device Deselected, or V _{IN} ≤ 0.3V or V _{IN} ≥ V _{DDQ} - 0.3V, f = f _{MAX} = 1/t _{CYC} | | 85 | mA |
| I _{SB4} | Automatic CS Power-down Current—TTL Inputs | V _{DD} = Max, Device Deselected, V _{IN} ≥ V _{IH} or V _{IN} ≤ V _{IL} , f = 0 | | 45 | mA |

Notes:

8. Overshoot: V_{IH}(AC) < V_{DD} + 1.5V (Pulse width less than t_{CYC}/2), undershoot: V_{IL}(AC) > -2V (Pulse width less than t_{CYC}/2).
 9. T_{Power-up}: Assumes a linear ramp from 0V to V_{DD}(min.) within 200 ms. During this time V_{IH} < V_{DD} and V_{DDQ} ≤ V_{DD}.

Capacitance^[10]

| Parameter | Description | Test Conditions | 100 TQFP Max. | Unit |
|------------------|--------------------------|---|---------------|------|
| C _{IN} | Input Capacitance | T _A = 25°C, f = 1 MHz, V _{DD} = 3.3V, V _{DDQ} = 2.5V | 5 | pF |
| C _{CLK} | Clock Input Capacitance | | 5 | pF |
| C _{I/O} | Input/Output Capacitance | | 5 | pF |

Thermal Resistance^[10]

| Parameter | Description | Test Conditions | 100 TQFP Package | Unit |
|-----------------|--|---|------------------|------|
| Θ _{JA} | Thermal Resistance (Junction to Ambient) | Test conditions follow standard test methods and procedures for measuring thermal impedance, per EIA/JESD51 | 30.32 | °C/W |
| Θ _{JC} | Thermal Resistance (Junction to Case) | | 6.85 | °C/W |

AC Test Loads and Waveforms

3.3V I/O Test Load

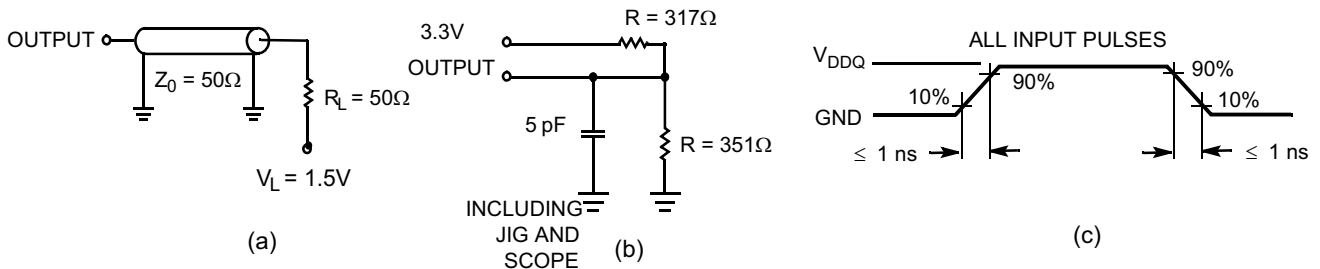

2.5V I/O Test Load

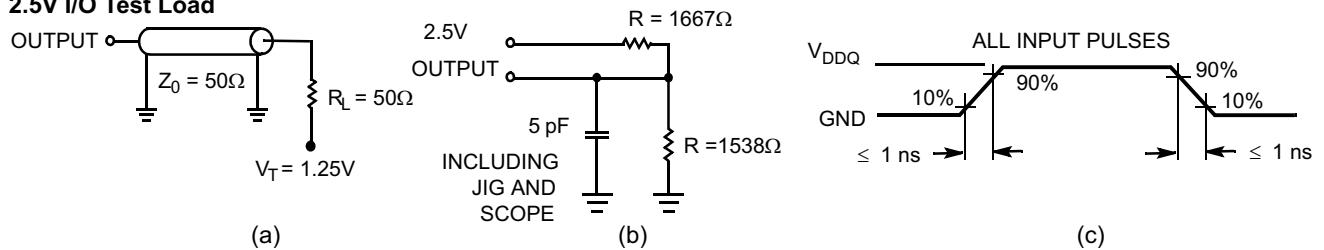

Note:
10. Tested initially and after any design or process change that may affect these parameters.

Switching Characteristics Over the Operating Range^[11, 12]

| Parameter | Description | -166 | | Unit |
|---------------------|---|------|------|------|
| | | Min. | Max. | |
| t _{POWER} | V _{DD} (Typical) to the First Access ^[13] | 1 | | ms |
| Clock | | | | |
| t _{CYC} | Clock Cycle Time | 6.0 | | ns |
| t _{CH} | Clock HIGH | 2.5 | | ns |
| t _{CL} | Clock LOW | 2.5 | | ns |
| Output Times | | | | |
| t _{CO} | Data Output Valid after CLK Rise | | 3.5 | ns |
| t _{DOH} | Data Output Hold after CLK Rise | 1.5 | | ns |
| t _{CLZ} | Clock to Low-Z ^[14, 15, 16] | 0 | | ns |
| t _{CHZ} | Clock to High-Z ^[14, 15, 16] | | 3.5 | ns |
| t _{OEV} | \overline{OE} LOW to Output Valid | | 3.5 | ns |
| t _{OELZ} | \overline{OE} LOW to Output Low-Z ^[14, 15, 16] | 0 | | ns |
| t _{OEHZ} | \overline{OE} HIGH to Output High-Z ^[14, 15, 16] | | 3.5 | ns |
| Set-up Times | | | | |
| t _{AS} | Address Set-up before CLK Rise | 1.5 | | ns |
| t _{ADS} | \overline{ADSC} , \overline{ADSP} Set-up before CLK Rise | 1.5 | | ns |
| t _{ADVS} | \overline{ADV} Set-up before CLK Rise | 1.5 | | ns |
| t _{WES} | \overline{GW} , \overline{BWE} , $\overline{BW}_{[A:D]}$ Set-up before CLK Rise | 1.5 | | ns |
| t _{DS} | Data Input Set-up before CLK Rise | 1.5 | | ns |
| t _{CES} | Chip Enable Set-Up before CLK Rise | 1.5 | | ns |
| Hold Times | | | | |
| t _{AH} | Address Hold after CLK Rise | 0.5 | | ns |
| t _{ADH} | \overline{ADSP} , \overline{ADSC} Hold after CLK Rise | 0.5 | | ns |
| t _{ADVH} | \overline{ADV} Hold after CLK Rise | 0.5 | | ns |
| t _{WEH} | \overline{GW} , \overline{BWE} , $\overline{BW}_{[A:D]}$ Hold after CLK Rise | 0.5 | | ns |
| t _{DH} | Data Input Hold after CLK Rise | 0.5 | | ns |
| t _{CEH} | Chip Enable Hold after CLK Rise | 0.5 | | ns |

Notes:

11. Timing reference level is 1.5V when V_{DDQ} = 3.3V and 1.25V when V_{DDQ} = 2.5V.
12. Test conditions shown in (a) of AC Test Loads unless otherwise noted.
13. This part has a voltage regulator internally; t_{POWER} is the time that the power needs to be supplied above V_{DD}(minimum) initially before a Read or Write operation can be initiated.
14. t_{CHZ}, t_{CLZ}, t_{OELZ}, and t_{OEHZ} are specified with AC test conditions shown in part (b) of AC Test Loads. Transition is measured ± 200 mV from steady-state voltage.
15. At any given voltage and temperature, t_{OEHZ} is less than t_{OELZ} and t_{CHZ} is less than t_{CLZ} to eliminate bus contention between SRAMs when sharing the same data bus. These specifications do not imply a bus contention condition, but reflect parameters guaranteed over worst case user conditions. Device is designed to achieve High-Z prior to Low-Z under the same system conditions.
16. This parameter is sampled and not 100% tested.

Switching Waveforms
Read Cycle Timing^[17]

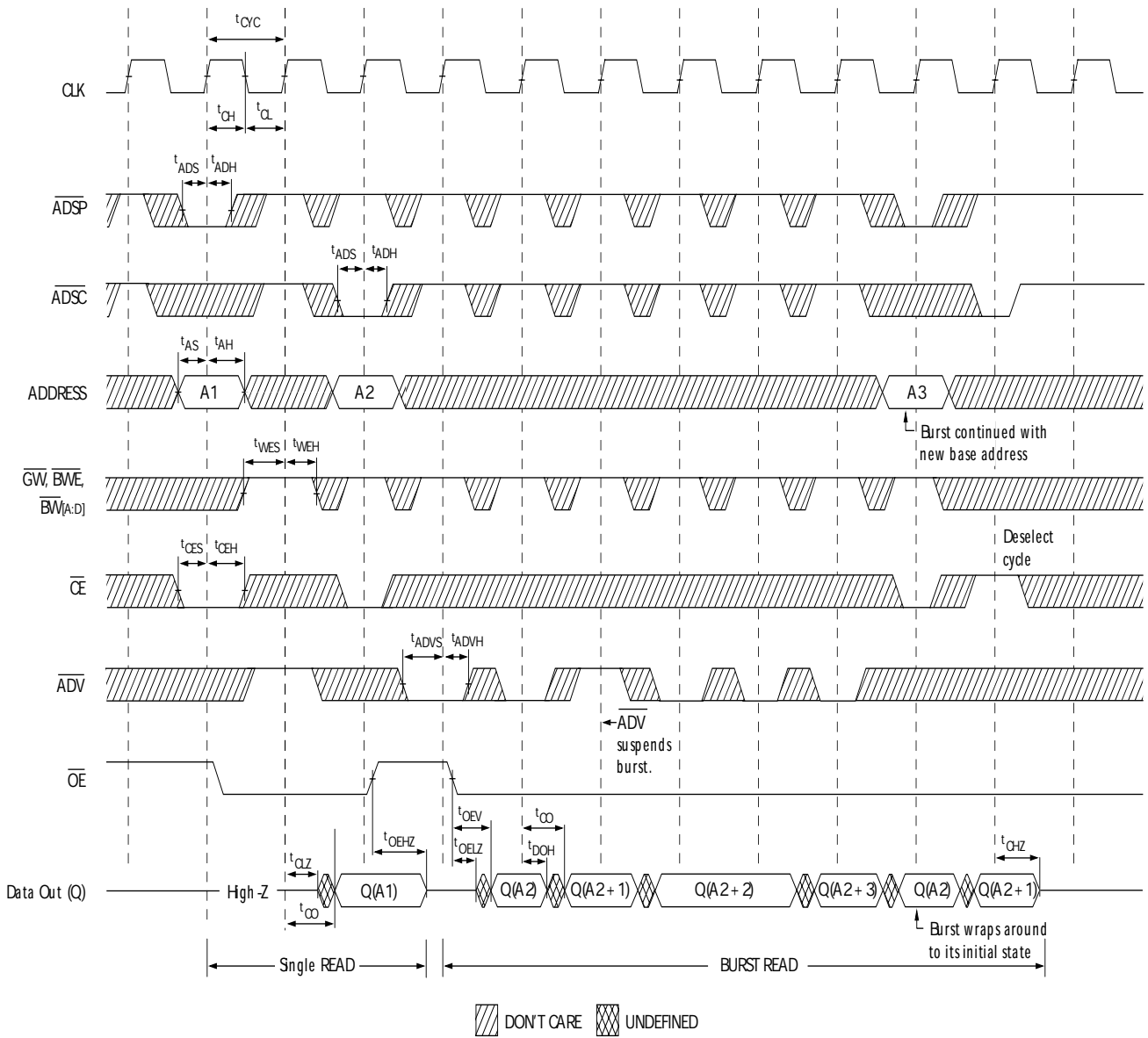

Note:

17. On this diagram, when \overline{CE} is LOW, \overline{CE}_1 is LOW, CE_2 is HIGH and \overline{CE}_3 is LOW. When \overline{CE} is HIGH, \overline{CE}_1 is HIGH or CE_2 is LOW or \overline{CE}_3 is HIGH.

Switching Waveforms (continued)
Write Cycle Timing^[17, 18]

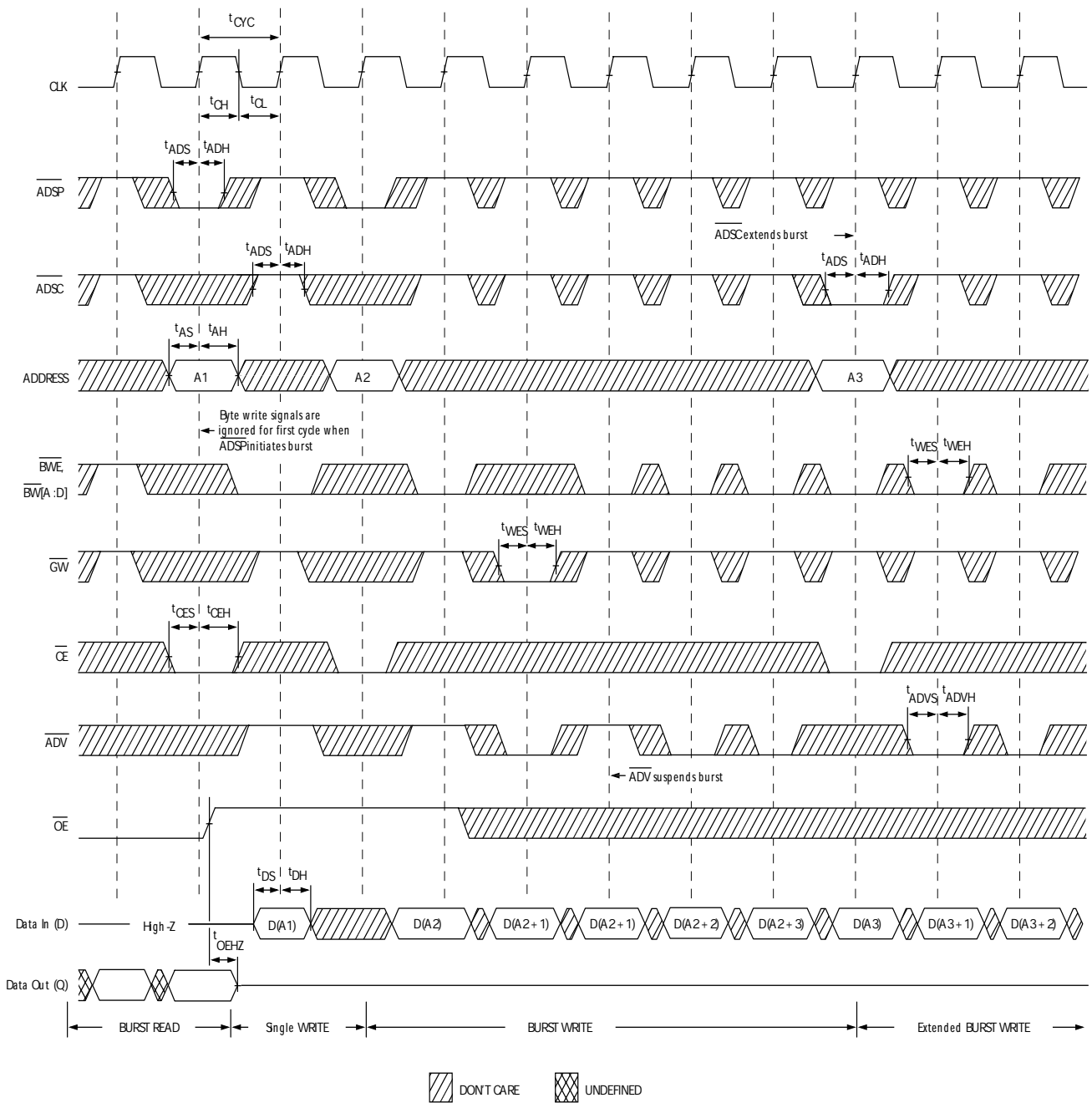

Note:
 18. Full width Write can be initiated by either \overline{GW} LOW; or by \overline{GW} HIGH, \overline{BWE} LOW and $\overline{BW}_{[A:D]}$ LOW.

Switching Waveforms (continued)
Read/Write Cycle Timing^[17, 19, 20]

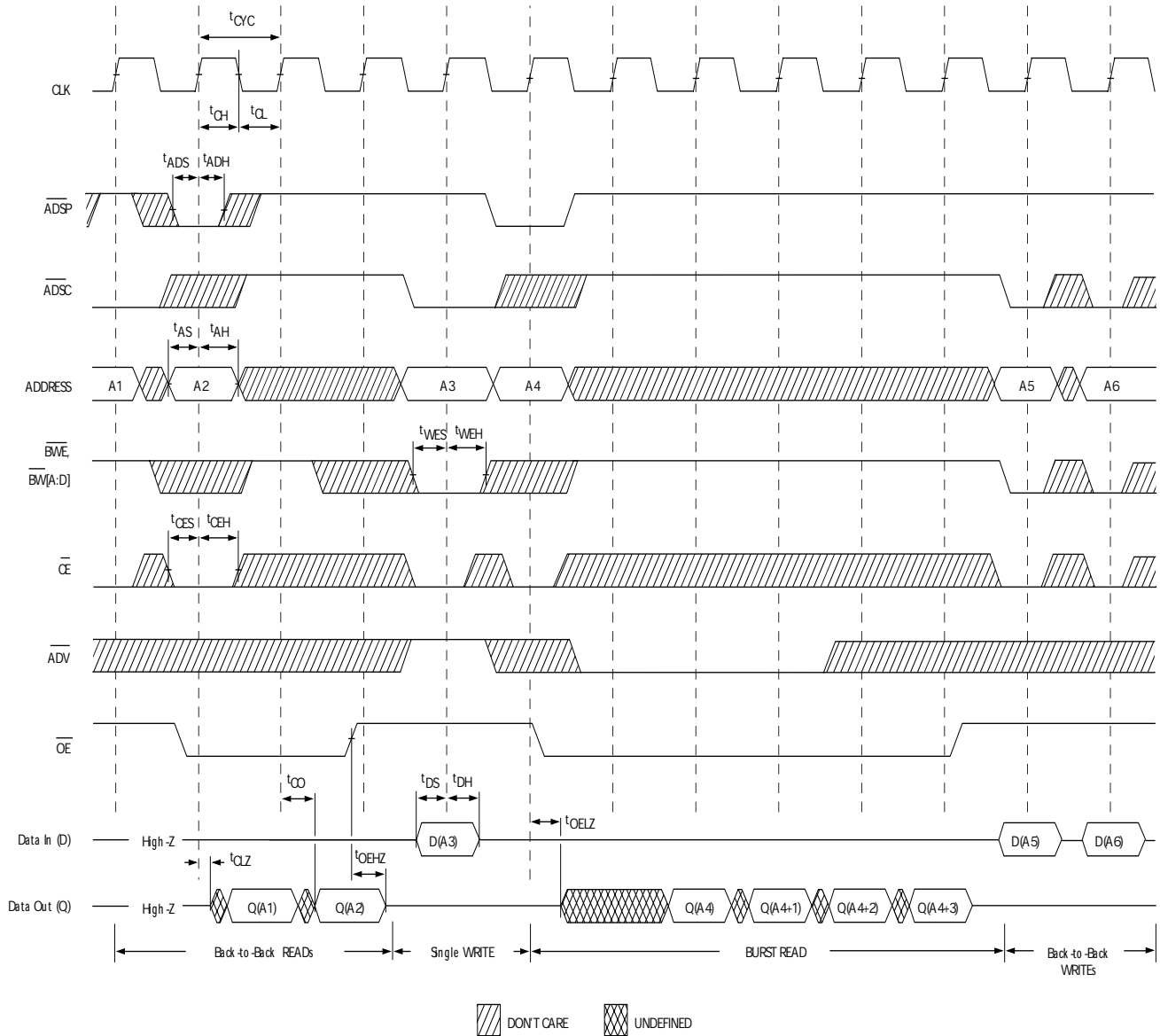

Notes:

- 19. The data bus (Q) remains in High-Z following a Write cycle unless an $\overline{\text{ADSP}}$, $\overline{\text{ADSC}}$, or $\overline{\text{ADV}}$ cycle is performed.
- 20. GW is HIGH.

Switching Waveforms (continued)
ZZ Mode Timing [21, 22]

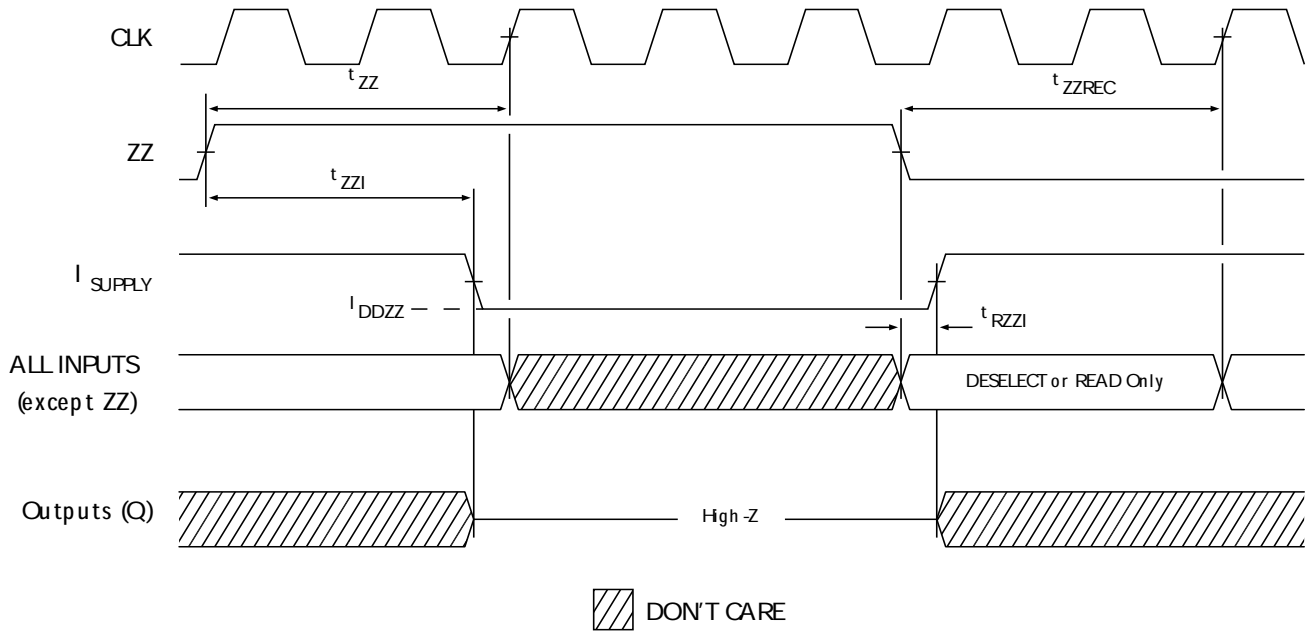

- Notes:**
- 21. Device must be deselected when entering ZZ mode. See Cycle Descriptions table for all possible signal conditions to deselect the device.
 - 22. DQs are in High-Z when exiting ZZ sleep mode.

Ordering Information

Cypress offers other versions of this type of product in many different configurations and features. The following table contains only the list of parts that are currently available.

For a complete listing of all options, visit the Cypress website at www.cypress.com and refer to the product summary page at <http://www.cypress.com/products> or contact your local sales representative.

Cypress maintains a worldwide network of offices, solution centers, manufacturer's representatives and distributors. To find the office closest to you, visit us at <http://www.cypress.com/go/datasheet/offices>.

| Speed (MHz) | Ordering Code | Package Diagram | Package Type | Operating Range |
|-------------|------------------|-----------------|--|-----------------|
| 166 | CY7C1346H-166AXC | 51-85050 | 100-pin Thin Quad Flat Pack (14 x 20 x 1.4 mm) Lead-Free | Commercial |

Package Diagrams

100-pin TQFP (14 x 20 x 1.4 mm) (51-85050)

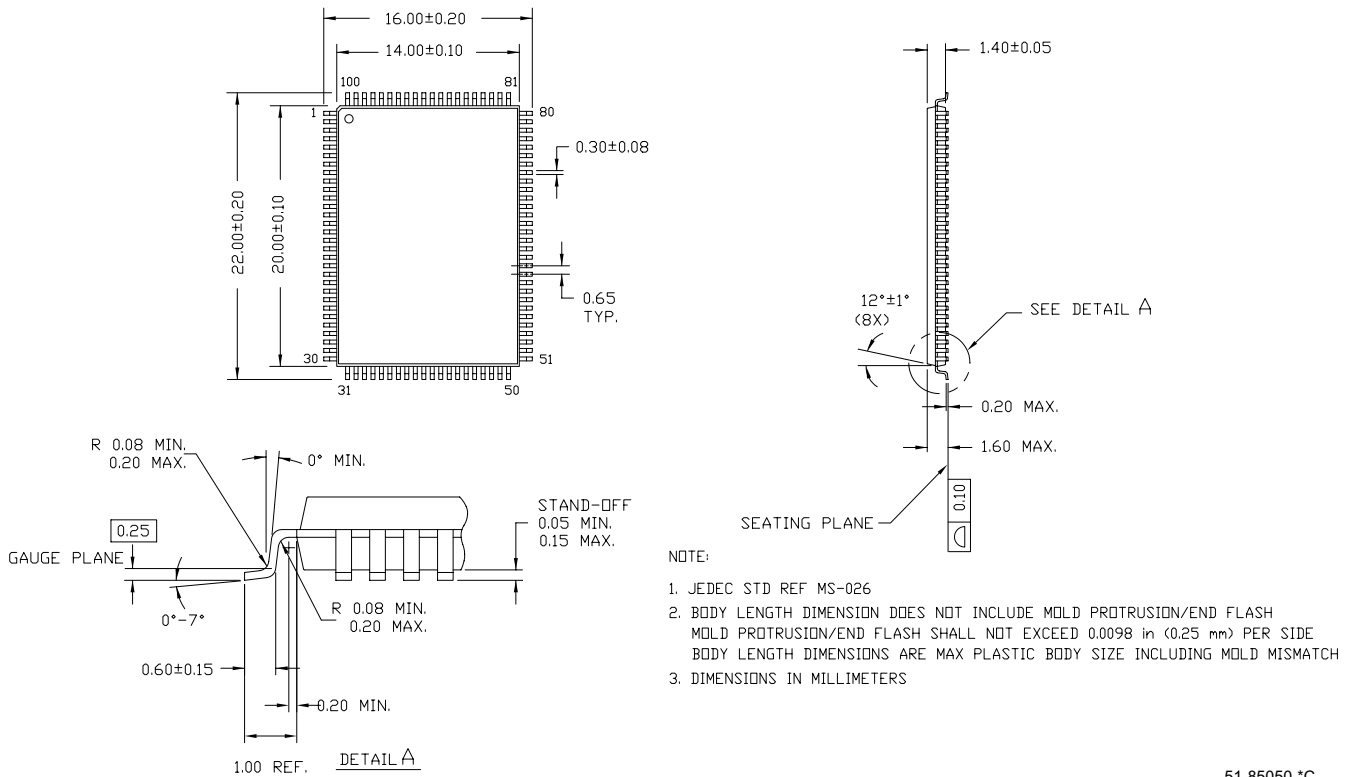

i486 is a trademark, and Intel and Pentium are registered trademarks, of Intel Corporation. PowerPC is a registered trademark of IBM Corporation. All product and company names mentioned in this document may be trademarks of their respective holders.

Document History Page

| Document Title: CY7C1346H 2-Mbit (64K x 36) Pipelined Sync SRAM Document Number: 38-05672 | | | | |
|--|---------|------------|-----------------|--|
| REV. | ECN NO. | Issue Date | Orig. of Change | Description of Change |
| ** | 347357 | See ECN | PCI | New Data sheet |
| *A | 420879 | See ECN | R XU | Converted from Preliminary to Final. Changed address of Cypress Semiconductor Corporation on Page# 1 from "3901 North First Street" to "198 Champion Court" Removed 133MHz Speed bin. Changed three-state to tri-state. Modified test condition from $V_{IH} \leq V_{DD}$ to $V_{IH} < V_{DD}$ Modified "Input Load" to "Input Leakage Current except ZZ and MODE" in the Electrical Characteristics Table. Replaced Package Name column with Package Diagram in the Ordering Information table. Replaced Package Diagram of 51-85050 from *A to *B |
| *B | 459347 | See ECN | NXR | Included 2.5V I/O option Updated the Ordering Information table. |
| *C | 2896585 | 03/20/2010 | NJY | Removed obsolete part numbers from Ordering Information table and updated package diagrams. |