

USB TYPE-C FULL-FEATURED RECEPTACLE INTERFACE PIN ASSIGNMENTS

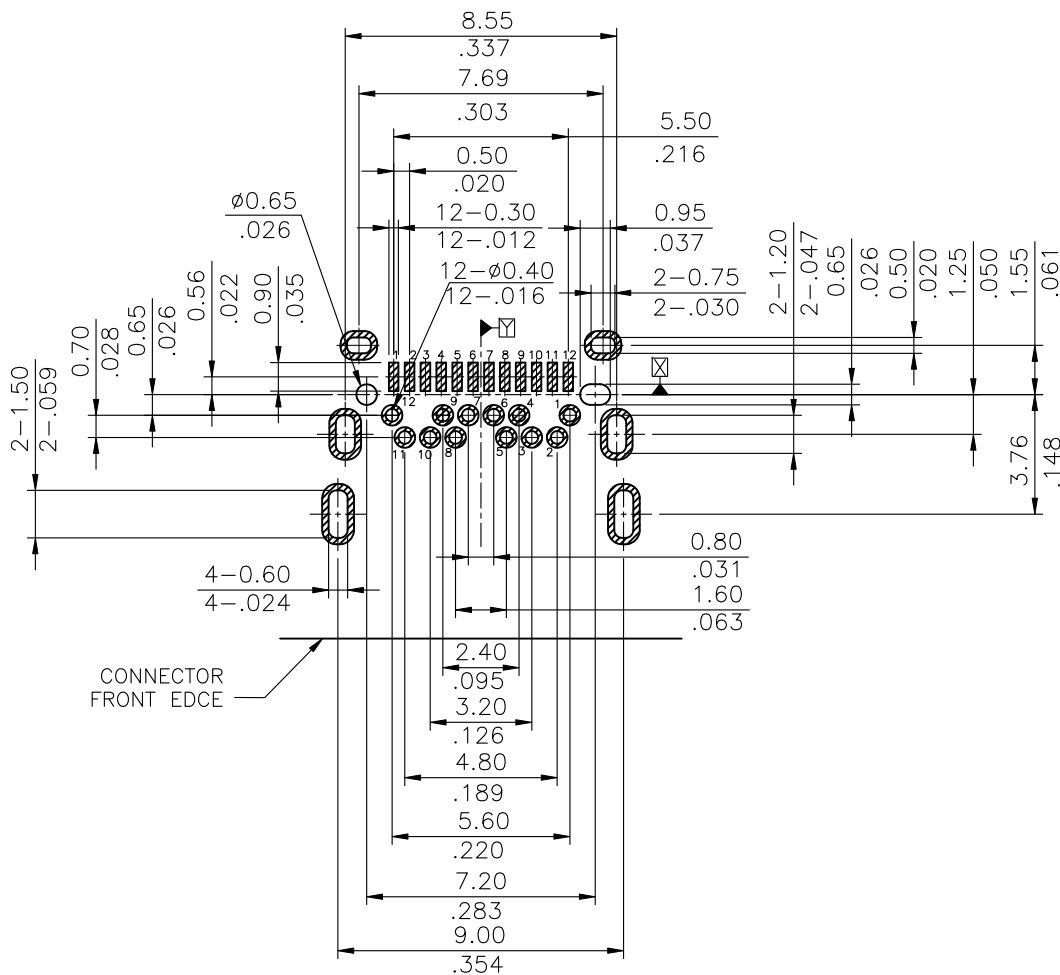

RECOMMENDED P.C.B. LAYOUT (T:1.00mm)  
TOLERANCE ±0.05mm

PIN	Signal Name	Description	PIN	Signal Name	Description
A1	GND	Ground return	B12	GND	Ground return
A2	SSTXp1	Positive half of first SuperSpeed TX differential pair	B11	SSRXp1	Positive half of first SuperSpeed RX differential pair
A3	SSTXn1	Negative half of first SuperSpeed TX differential pair	B10	SSRXn1	Negative half of first SuperSpeed RX differential pair
A4	Vbus	Bus Power	B9	VBUS	Bus Power
A5	CC1	Configuration Channel	B8	SBU2	Sideband Use(SBU)
A6	Dp1	Positive half of the USB 2.0 differential pair-Position 1	B7	Dn2	Negative half of the USB 2.0 differential pair-Position 2
A7	Dn1	Negative half of the USB 2.0 differential pair-Position 1	B6	Dp2	Positive half of the USB 2.0 differential pair-Position 2
A8	SBU1	Sideband Use(SBU)	B5	CC2	Configuration Channel
A9	VBUS	Bus Power	B4	VBUS	Bus Power
A10	SSRXn2	Negative half of second SuperSpeed RX differential pair	B3	SSTXn2	Negative half of second SuperSpeed TX differential pair
A11	SSRXp2	Positive half of second SuperSpeed RX differential pair	B2	SSTXp2	Positive half of second SuperSpeed TX differential pair
A12	GND	Ground return	B1	GND	Ground return

Lead Free Process

RoHS Compliant

4					DATE	UNIT: mm / inch	TITLE: U.S.B TYPE C SOCKET DIP+SMT TOP MOUNT RIGHT ANGLE
3				DRAWN BY: Mark	11/17-17'	TOLERANCE UNLESS OTHERWISE SPECIFIED	MATERIAL:  FINISH:
2				ENGINEER: Mark	11/17-17'	.X ± 0.25/010 X' ± 4'	
1	Mark	8/29-17'	ECRD117003	CHECKED BY: Andy	11/17-17'	.XX ± 0.20/008 .X' ± 2'	
SYM	NAME	DATE	REVISIONS	APPROVED BY: Andy	11/17-17'	.XXX ± 0.10/004 .XX' ±	



瀚荃股份有限公司  
CviLux Corporation

DRAWING NO.	CU1826SB	PART NO.	CU1824S*H1PD*RO-LF-HC
SCALE	4 / 1	SHEET	2 OF 3

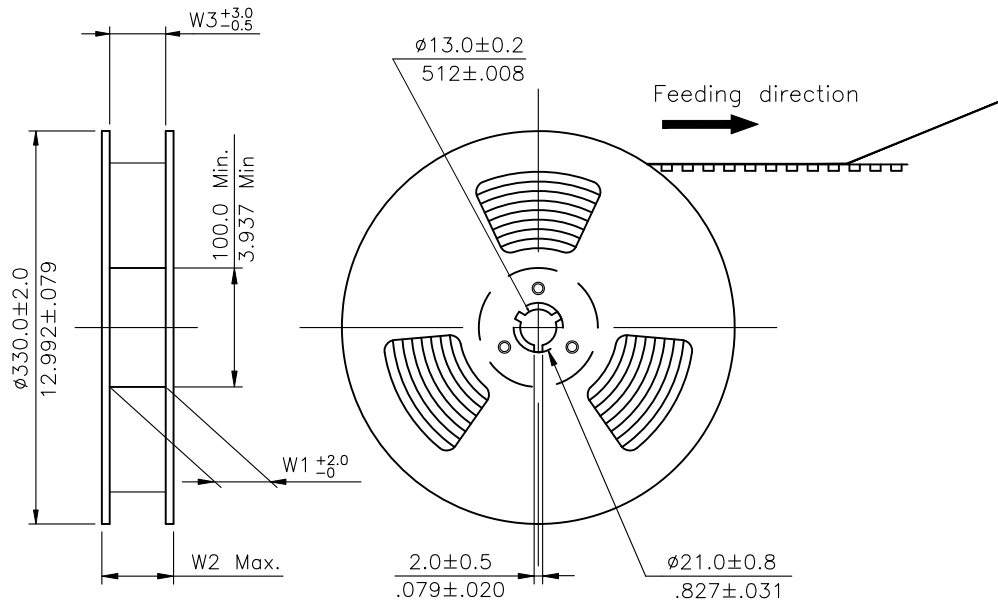

NOTE :

- \* Reel Material : HIPS
- \* Carrier Material : Clear, Conductive Polystyrene Alloy
- \* Cover Tape Material : Polyester
- \* Cover Tape Peel Strength : 0.1N – 1.3N
- \* Carrier camber is within 1mm in 250mm
- \* All dimensions meet EIA-481-B requirements.
- \* Quantity : 1000 PCS/Reel

Dimension				Packing (Reel/Carton)
E	W1	W2	W3	
24.0(.945)	24.5(.965)	30.5(1.201)	24.5(.965)	10

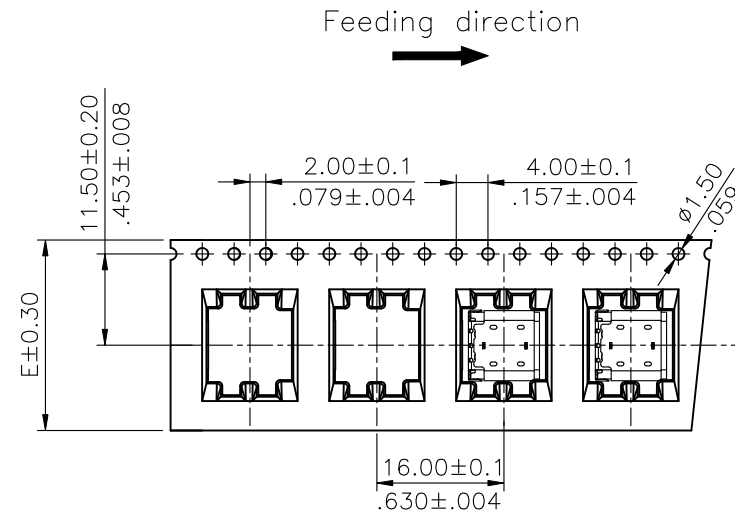
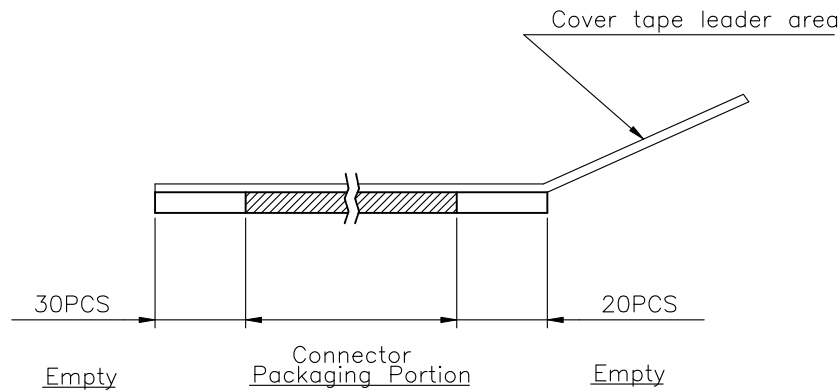

WIDTH : 24 mm Carrie

RoHS Compliant

4					DATE	UNIT: mm / inch	TITLE: U.S.B TYPE C SOCKET DIP+SMT Top mount Straight	 瀚荃股份有限公司 CviLux Corporation		
3				DRAWN BY:	Mark	11/17-17'	MATERIAL:			
2				ENGINEER:	Mark	11/17-17'		FINISH:		
1	Mark	8/29-17'	ECRD117003	CHECKED BY:	Andy	11/17-17'	DRAWING NO.		CU1826SB	PART NO.
SYM	NAME	DATE	REVISIONS	APPROVED BY:	Andy	11/17-17'	SCALE		SHEET	3 OF 3