

UNIT : mm

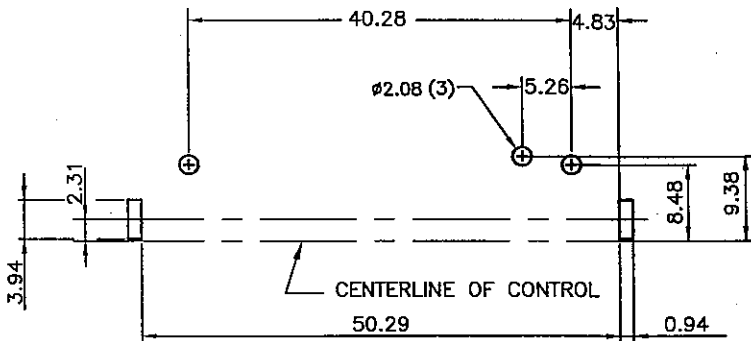

PCB LAYOUT
GENERAL TOL ±0.05

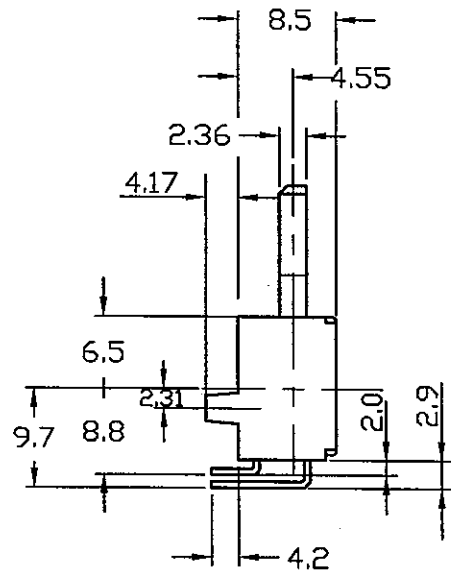
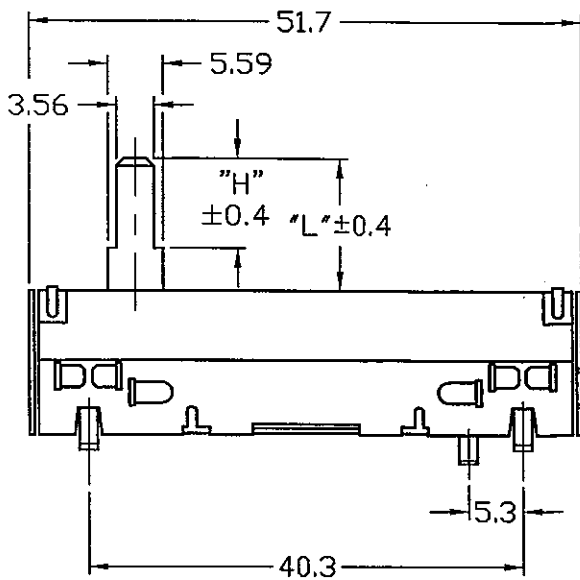
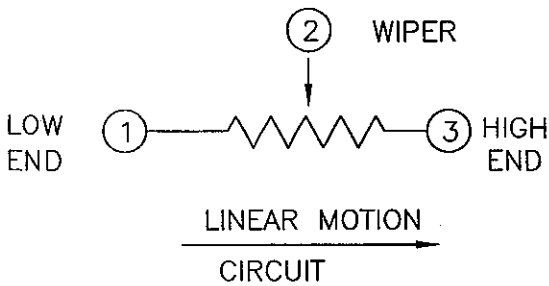

NOTES:

1. RESISTANCE : 1K±10%
2. RESIDUAL RESISTANCE :
HEHO : 35 ohms max.
LEHO : 35 ohms max.
3. CURVE TYPE : LINEAR CTS TYPE LD
4. DIMENSIONS OF
L : 25.4 H : 9.5
5. FOR ADDITIONAL REQUIREMENTS SEE CTS
ENG. SPEC. EN-SPE-442001A

CTS

COMPONENTS TAIWAN LTD.
KAOHSIUNG, TAIWAN, ROC

CAD LIST : ACAD(B)-CATALOG-78
FILE NAME : 442USM01

PART NO. UX5049

REV

CUSTOMER : Automation Components

SCALE : NONE

TOLERANCE UNLESS OTHERWISE
SPECIFIED

DRAWN BY : F. S.

APPROVED BY :

CTS TYPE : U-SM442SF

.X (1 PLACE) : ±0.3
.XX (2 PLACE) : ±0.13
ANGLE : ±5°

CHECKED BY :

ISSUED DATE : 07-03-07