

### FEATURES

- Standard 7mmx5mm Surface Mount Footprint
- HCMOS/TTL Compatible Output
- Frequency Range 1.5 – 77.76 MHz, 122.88 MHz
- **Fundamental Crystal Design**
- Frequency Stability,  $\pm 50$  ppm Standard ( $\pm 25$  ppm and  $\pm 20$  ppm available)
- +3.3Vdc or +5.0Vdc Operation
- Operating Temperature to  $-40^{\circ}\text{C}$  to  $+85^{\circ}\text{C}$
- Output Enable Standard
- Low Phase Jitter
- Tape & Reel Packaging
- **RoHS/Green Compliant (6/6)**

### DESCRIPTION

The Model 357 is a ceramic packaged Voltage Controlled oscillator offering reduced size and enhanced stability. The small size means it is perfect for any application. The enhanced stability means it is the perfect choice for today's communications applications that require tight frequency control.



### ORDERING INFORMATION

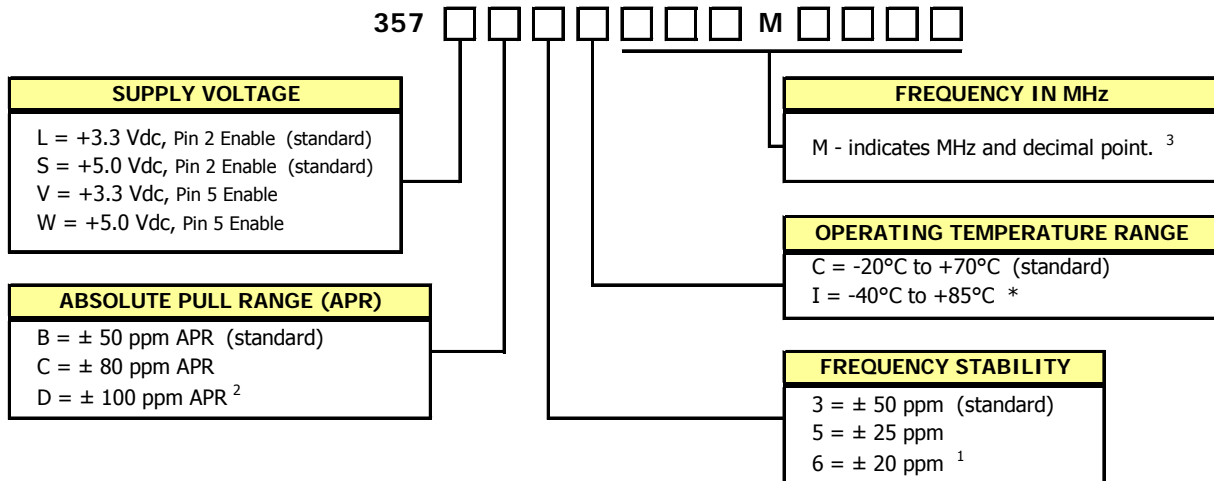

1] 6I Stability/Temperature combination is not available.

2] Consult factory for availability.

3] Frequency is recorded with 3 significant digits before the 'M' and 4 significant digits after the 'M' (including zeros).

[Ex. XXXMXXXX (008M0000), XXXMXXXX (049M1520), XXXMXXXX (122M8800)]

**Not all performance combinations and frequencies may be available.  
Contact your local CTS Representative or CTS Customer Service for availability.**

## ELECTRICAL CHARACTERISTICS

	PARAMETER	SYMBOL	CONDITIONS	MIN	TYP	MAX	UNIT
<b>Absolute Maximums</b>	Maximum Supply Voltage	$V_{CC}$	-	-0.5	-	7.0	V
	Maximum Control Voltage	$V_C$	-	-0.5	-	$V_{CC}$	V
	Storage Temperature	$T_{STG}$	-	-55	-	125	°C
	Frequency Range	$f_O$	-	1.5 - 77.76, 122.88			MHz
	Frequency Stability (See Note 1 and Ordering Information)	$\Delta f/f_O$	-	-	-	20, 25 or 50	± ppm
	Absolute Pull Range (See Note 2 and Ordering Information)	APR	-	50, 80 or 100	-	-	± ppm
	Operating Temperature	$T_A$	Commercial Industrial	-20 -40	25	70 85	°C
Supply Voltage	$V_{CC}$	Model 357S, 357W, ± 10 % Model 357L, 357V, ± 10 %	4.5 2.97	5.0 3.3	5.5 3.63	V	
Supply Current	$I_{CC}$	$C_L = 15$ pF 1.5 MHz to 20 MHz 20.1 MHz to 40 MHz 40.1 MHz to 60 MHz 60.1 MHz to 80 MHz, 122.88 MHz	- - - -	5 8 10 12	20 30 40 45	mA	
Output Load	$C_L$	< 80 MHz ≥ 80 MHz	- -	- -	30 15	pF	
Control Voltage	$V_C$	Model 357S, 357W, $V_{CC} = 5.0V$ Model 357L, 357V, $V_{CC} = 3.3V$	0.5 0.3	2.5 1.65	4.5 3.0	V	
Leakage Current @ $V_C$ Input	-	-	-1	-	1.0	µA	
Frequency Deviation	$\Delta f$	25°C at Time of Shipment, over $V_C$ range	-	-	±200	ppm	
Linearity Best Straight Line Fit	L	< 52 MHz > 52 MHz	- -	5 8	10 15	%	
Output Duty Cycle	SYM	@ 50% Level	45	-	55	%	
Output Voltage Levels	$V_{OH}$ $V_{OL}$	Logic '1' Level, CMOS Load Logic '0' Level, CMOS Load	90% $V_{CC}$ -	- -	- 10% $V_{CC}$	V	
Output Current Levels	$I_{OH}$ $I_{OL}$	Logic '1' Level, CMOS Load Logic '0' Level, CMOS Load	- -	- -	-14 14	mA	
Rise and Fall Time	$T_{R}$ , $T_{F}$	@ 10% - 90% Levels	-	3.5	5.0	ns	
Input Impedance	$Z_{V_C}$	-	50	-	-	kOhms	
Transfer Function	-	-	-	Positive	-	-	
Start Up Time	$T_S$	Application of $V_{CC}$	-	-	10	ms	
Modulation Roll-off	-	@ -3dB	10	-	-	kHz	
Phase Jitter	tj <sub>rms</sub>	Bandwidth 12 kHz - 20 MHz	-	-	1	ps RMS	
Enable Function							
Enable Input Voltage	$V_{IH}$	Pin 2 or Pin 5 Logic '1', Output Enabled	2.5	-	-	V	
Disable Input Voltage	$V_{IL}$	Pin 2 or Pin 5 Logic '0', Output Disabled	-	-	0.5		
Enable Time	$T_{PLZ}$	Pin 2 or Pin 5 Logic '1'	-	-	100	ns	

**Notes:**

- Inclusive of initial tolerance at time of shipment, changes in supply voltage, load, temperature and 1year aging.
- Minimum guaranteed frequency shift from  $f_O$  over variations in temperature, aging, power supply and load.

**SINGLE SIDE BAND PHASE NOISE**  
**(typical maximum)**

Frequency Offset	Phase Noise (dBc/Hz) *	Frequency Offset	Phase Noise (dBc/Hz) *
10 Hz	-60	10k Hz	-135
100 Hz	-90	100k Hz	-150
1k Hz	-120	≥ 100k Hz	-150

\* Results may vary depending on frequency.

### CMOS/TTL OUTPUT WAVEFORM

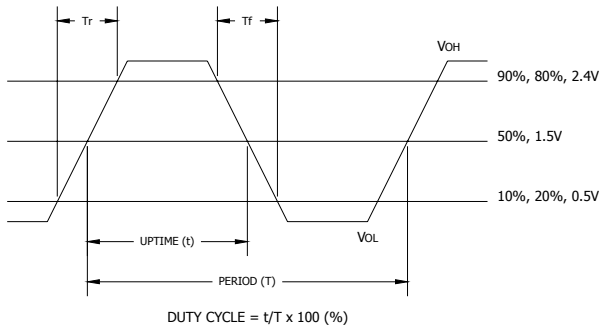

### D.U.T. PIN ASSIGNMENTS

PIN	SYMBOL	DESCRIPTION
1	V <sub>C</sub>	Control Voltage
2	EOH or N.C.	Enable or No Connect
3	GND	Circuit & Package Ground
4	Output	RF Output
5	N.C. or EOH	No Connect or Enable
6	V <sub>CC</sub>	Supply Voltage

### TEST CIRCUIT, CMOS LOAD

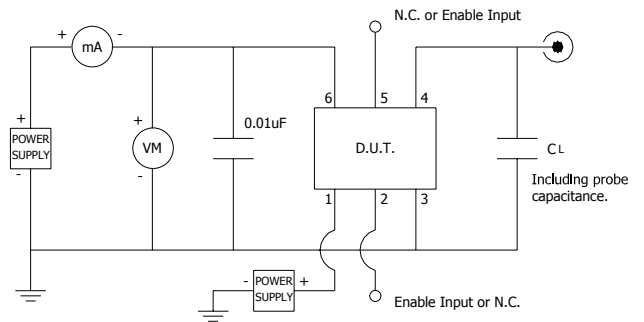

### ENABLE TRUTH TABLE

PIN 2 or PIN 5	PIN 4
Logic '1'	Output
Open	Output
Logic '0'	High Imp.

## MECHANICAL SPECIFICATIONS

### PACKAGE DRAWING

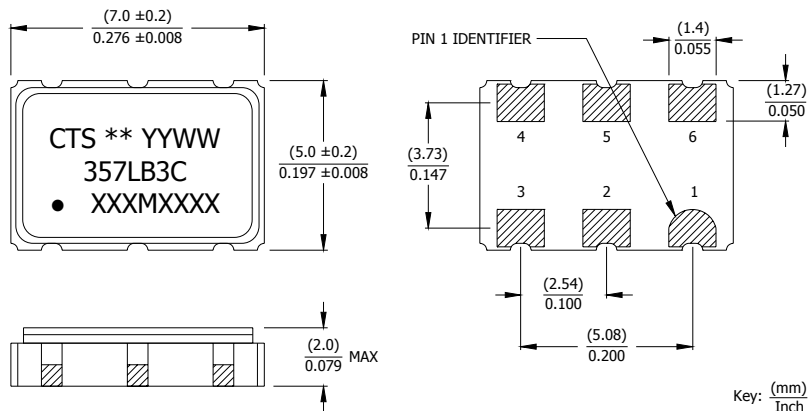

### MARKING INFORMATION

- \*\* - Manufacturing Site Code.
- YYWW - Date code, YY - year, WW - week.
- Truncated CTS part number.
- XXXMXXXX - Frequency marked with 4 significant digits after the 'M'.

### NOTES

- Termination pads (e4), barrier-plating is nickel (Ni) with gold (Au) flash plate.
- Reflow conditions per JEDEC J-STD-020.

### SUGGESTED SOLDER PAD GEOMETRY

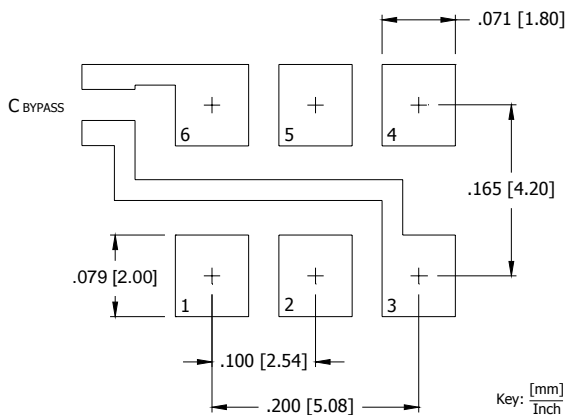

C<sub>BYPASS</sub> should be ≥ 0.01 uF.

## TAPE AND REEL INFORMATION

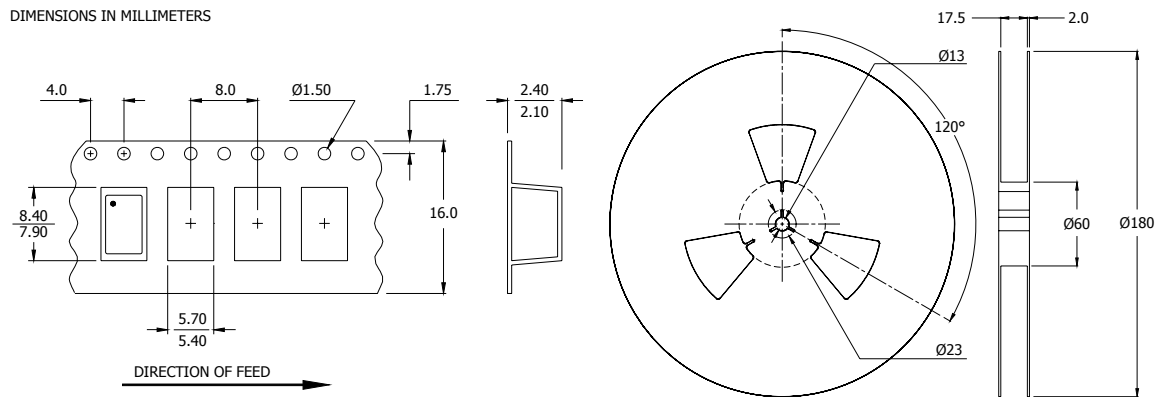

Device quantity is 1,000 pieces per 180mm reel.

## ENVIRONMENTAL SPECIFICATIONS

Temperature Cycle:	400 cycles from $-55^{\circ}\text{C}$ to $+125^{\circ}\text{C}$ , 10 minute dwell at each temperature, 1 minute transfer time between temperatures.
Mechanical Shock:	1,500g's, 0.5mS duration, $\frac{1}{2}$ sinewave, 3 shocks each direction along 3 mutually perpendicular planes (18 total shocks).
Sinusoidal Vibration:	0.06 inches double amplitude, 10 to 55 Hz and 20g's, 55 to 2,000 Hz, 3 cycles each in 3 mutually perpendicular planes (9 times total).
Gross Leak:	No leak shall appear while immersed in an FC40 or equivalent liquid at $+125^{\circ}\text{C}$ for 20 seconds.
Fine Leak:	Mass spectrometer leak rates less than $2 \times 10^{-8}$ ATM cc/sec air equivalent.
Resistance to Solder Heat:	Product must survive 3 reflows of $+260^{\circ}\text{C}$ peak, 10 seconds maximum.
High Temperature Operating Bias:	2,000 hours at $+125^{\circ}\text{C}$ , maximum bias, disregarding frequency shift.
Frequency Aging:	1,000 hours at $+85^{\circ}\text{C}$ , full bias, less than $\pm 5$ ppm shift.
Moisture Sensitivity Level:	Level 1 per JEDEC J-STD-020.