

PBA150F



Features

- Harmonic attenuator, PFC (Complies with IEC61000-3-2)
- Universal input (AC85-264V)
- Super small-size & light weight
- Making to high effective by synchronous rectification technology (PBA50F - 150F)
- High variety of options (PBA50F - 150F)
- Parallel operation and Parallel redundancy operation
- Fan alarm, Remote ON/OFF and other functions(PBA300F - 1500F)
- RoHS Compliant

Safety Agency Approvals

- Complies with DEN-AN
- UL60950-1, C-UL(CSA60950-1), EN60950-1, EN50178
- UL508 (PBA50F - 150F, -24, with cover),

EMI Compliance

- FCC-B
- CISPR22-B
- EN55022-B
- VCCI-B
- EN55011-B

CE Markings

- LVD and EMC directive

EMC Compliance

- EN61000-4-2
- EN61000-4-3
- EN61000-4-4
- EN61000-4-5
- EN61000-4-6
- EN61000-4-8
- EN61000-4-11

5 year warranty(refer to Instruction Manual)

Model	Input Voltage [V]	Output Wattage [W]	DC Output [V/A]
PBA150F-3R3	DC 120 - 370 AC 85 - 264	99	3.3V 30A
PBA150F-5	DC 120 - 370 AC 85 - 264	150	5V 30A
PBA150F-9	DC 120 - 370 AC 85 - 264	150.3	9V 16.7A
PBA150F-12	DC 120 - 370 AC 85 - 264	156	12V 13A
PBA150F-15	DC 120 - 370 AC 85 - 264	150	15V 10A
PBA150F-24	DC 120 - 370 AC 85 - 264	156	24V 6.5A
PBA150F-36	DC 120 - 370 AC 85 - 264	154.8	36V 4.3A
PBA150F-48	DC 120 - 370 AC 85 - 264	158.4	48V 3.3A



RoHS

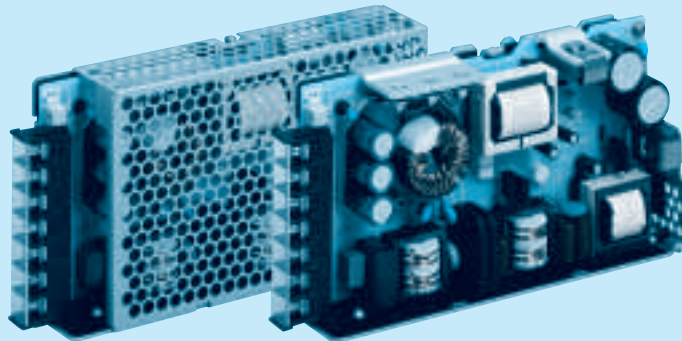

Recommended Noise Filter
NAC-06-472



High voltage pulse noise type : NAP series
Low leakage current type : NAM series
* The Noise Filter is recommended to connect with several devices.

- ① Series name
② Single output
③ Output wattage
④ Universal input
⑤ Output voltage
⑥ Optional
C : with Coating
G : Low leakage current (0.15mA max / ACIN 240V)
E : Low leakage current and EMI class A (0.5mA max / ACIN 240V)
T : Vertical terminal block
J : Connector type (Only -12,-15,-24,-36,-48)
R : with Remote ON/OFF
N : with Cover (Only 24V UL508 is acquired)
N1 : with DIN rail
V : Output voltage setting potentiometer externally

Cover is optional

MODEL	PBA150F-3R3	PBA150F-5	PBA150F-9	PBA150F-12	PBA150F-15	PBA150F-24	PBA150F-36	PBA150F-48
MAX OUTPUT WATTAGE[W]	99	150	150.3	156	150	156	154.8	158.4
DC OUTPUT	3.3V 30A	5V 30A	9V 16.7A	12V 13A	15V 10A	24V 6.5A	36V 4.3A	48V 3.3A

SPECIFICATIONS

	MODEL	PBA150F-3R3	PBA150F-5	PBA150F-9	PBA150F-12	PBA150F-15	PBA150F-24	PBA150F-36	PBA150F-48	
INPUT	VOLTAGE[V]	AC85 - 264 1φ or DC120 - 370 (AC50 or DC70 Please refer to the instruction manual 2.1 Input voltage *4)								
	CURRENT[A]	ACIN 100V	1.3typ	2.0typ						
		ACIN 200V	0.7typ	1.0typ						
	FREQUENCY[Hz]	50/60 (47 - 63)								
	EFFICIENCY[%]	ACIN 100V	80typ	83typ	82typ	83typ	84typ	85typ	85typ	85typ
		ACIN 200V	82typ	86typ	85typ	86typ	87typ	88typ	88typ	88typ
	POWER FACTOR(lo=100%)	ACIN 100V	0.98typ	0.99typ						
		ACIN 200V	0.87typ	0.93typ						
INRUSH CURRENT[A]	ACIN 100V	20typ (lo=100%) (At cold start)								
	ACIN 200V	40typ (lo=100%) (At cold start)								
LEAKAGE CURRENT[mA]	0.4/0.75max (ACIN 100V/240V 60Hz, lo=100%, According to IEC60950-1.DENAN)									
OUTPUT	VOLTAGE[V]	3.3	5	9	12	15	24	36	48	
	CURRENT[A]	30	30	16.7	13	10	6.5	4.3	3.3	
	LINE REGULATION[mV]	20max	20max	36max	48max	60max	96max	144max	192max	
	LOAD REGULATION[mV]	40max	40max	100max	100max	120max	150max	240max	240max	
	RIPPLE[mVp-p]	0 to +50°C *1	80max	80max	120max	120max	120max	120max	150max	150max
		-10 - 0°C *1	140max	140max	160max	160max	160max	160max	200max	200max
	RIPPLE NOISE[mVp-p]	0 to +50°C *1	120max	120max	150max	150max	150max	150max	250max	250max
		-10 - 0°C *1	160max	160max	180max	180max	180max	180max	300max	300max
	TEMPERATURE REGULATION[mV]	0 to +50°C	50max	50max	90max	120max	150max	240max	360max	480max
		-10 to +50°C	60max	60max	120max	150max	180max	290max	450max	600max
	DRIFT[mV]	*2	20max	20max	36max	48max	60max	96max	144max	192max
	START-UP TIME[ms]	350typ(ACIN 100V, lo=100%)								
	HOLD-UP TIME[ms]	20typ (ACIN 100V, lo=100%)								
OUTPUT VOLTAGE ADJUSTMENT RANGE[V]	2.85 - 3.63	4.00 - 5.50	7.50 - 10.0	10.0 - 13.2	13.2 - 18.0	19.2 - 27.0	28.8 - 39.6	39.0 - 53.0		
OUTPUT VOLTAGE SETTING[V]	3.30 - 3.40	5.00 - 5.15	9.00 - 9.36	12.00 - 12.48	15.00 - 15.60	24.00 - 24.96	36.00 - 37.44	48.00 - 49.92		
PROTECTION CIRCUIT AND OTHERS	OVERCURRENT PROTECTION	Works over 105% of rated current and recovers automatically								
	OVERVOLTAGE PROTECTION[V]	4.00 - 5.25	5.75 - 7.00	11.5 - 14.0	15.0 - 18.0	20.0 - 25.0	30.0 - 37.0	43.0 - 50.0	58.0 - 65.0	
	OPERATING INDICATION	LED (Green)								
	REMOTE SENSING	Optional (Only -3R3, -5 Option -K)								
ISOLATION	REMOTE ON/OFF	Optional (Required external power source)								
	INPUT-OUTPUT · RC	*3	AC3,000V 1minute, Cutoff current = 10mA, DC500V 50MΩmin (At Room Temperature)							
	INPUT-FG	*3	AC2,000V 1minute, Cutoff current = 10mA, DC500V 50MΩmin (At Room Temperature)							
ENVIRONMENT	OUTPUT · RC-FG	*3	AC500V 1minute, Cutoff current = 100mA, DC500V 50MΩmin (At Room Temperature)							
	OPERATING TEMP., HUMID. AND ALTITUDE	-10 to +71°C (Required Derating), 20 - 90%RH (Non condensing) 3,000m (10,000feet) max								
	STORAGE TEMP., HUMID. AND ALTITUDE	-20 to +75°C, 20 - 90%RH (Non condensing) 3,000m (10,000feet) max								
	VIBRATION	10 - 55Hz, 19.6m/s ² (2G), 3minutes period, 60minutes each along X, Y and Z axis								
SAFETY AND NOISE REGULATIONS	IMPACT	196.1m/s ² (20G), 11ms, once each X, Y and Z axis								
	AGENCY APPROVALS (At only AC input)	UL60950-1, C-UL(CSA60950-1), EN60950-1, EN50178 Complies with DEN-AN								
	CONDUCTED NOISE	Complies with FCC Part15 classB, VCCI-B, CISPR22-B, EN55011-B, EN55022-B								
	CE MARKING	Low Voltage Directive, EMC Directive								
OTHERS	HARMONIC ATTENUATOR	Complies with IEC61000-3-2								
	CASE SIZE/WEIGHT	34 × 93 × 168mm (without terminal block) (W × H × D) / 560g max (without cover)								
	COOLING METHOD	Convection								

- *1 Measured by 20MHz oscilloscope or Ripple-Noise meter(equivalent to KEISOKU-GIKEN :RM101).
*2 Drift is the change in DC output for an eight hour period after a half-hour warm-up at 25°C.
*3 Applicable when Remote ON/OFF(optional) is added. RC is insulated with input, output and FG.
*4 Derating is required.

- * Parallel operation with other model is not possible.
* Derating is required when operated with cover.
* A sound may occur from power supply at peak loading.

Block diagram

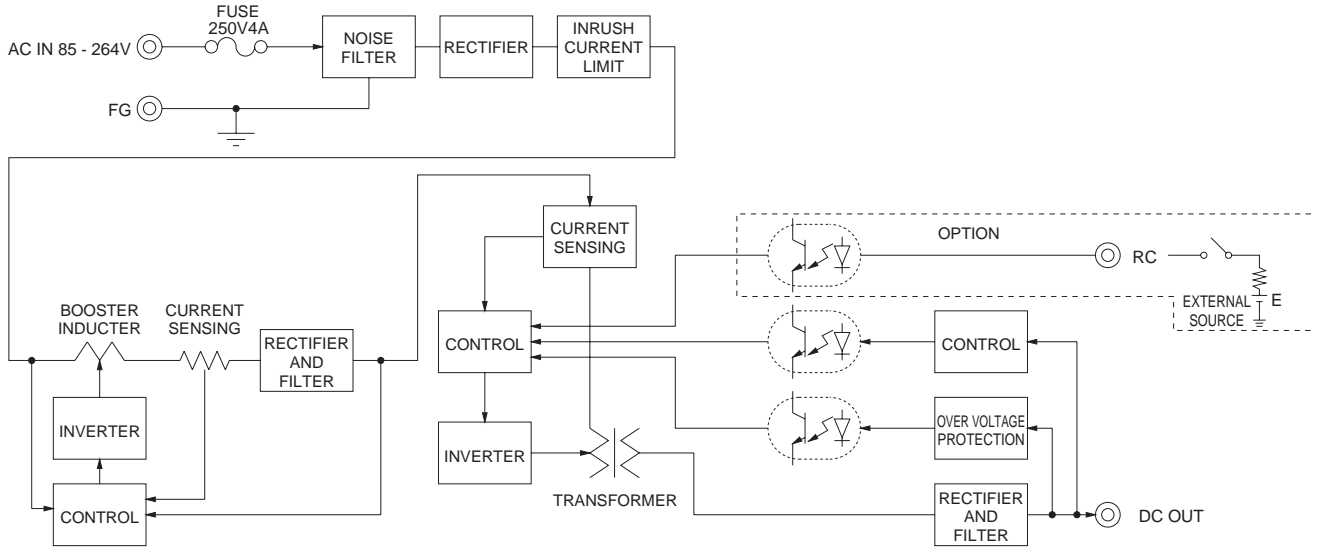

External view

※ External size of option T,J,R,N,N1,V and K is different from standard model and refer to 7 Option of instruction manual for details.

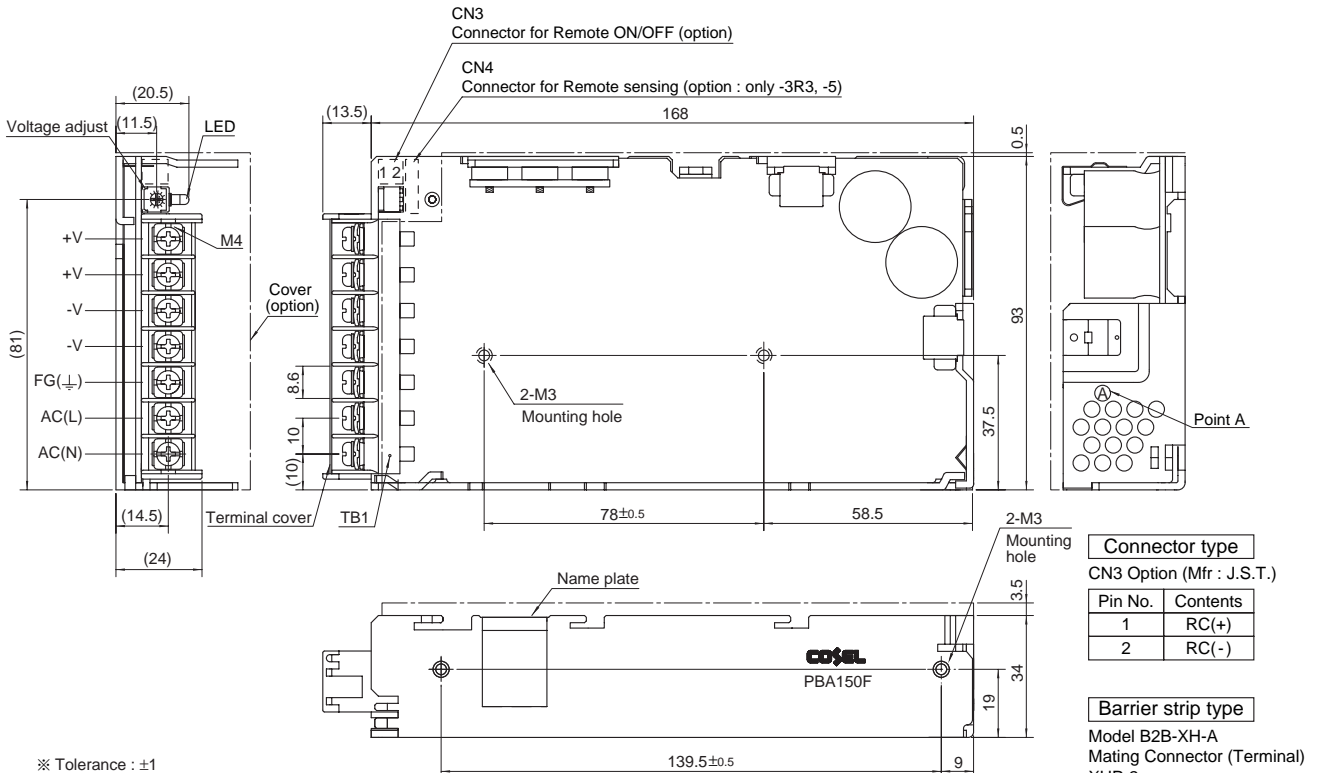

Connector type	
CN3 Option (Mfr : J.S.T.)	
Pin No.	Contents
1	RC(+)
2	RC(-)

Barrier strip type	
Model B2B-XH-A	
Mating Connector (Terminal)	
XHP-2	
(BXH-001T-P0.6)	
(or SXH-001T-P0.6)	

- ※ Tolerance : ±1
- ※ Mass : 560g or less (without cover)
- ※ PCB Material/thickness : CEM3 / 1.6mm
- ※ Chassis material : Aluminum
- ※ Dimensions in mm
- ※ Mounting torque : 0.49N • m(5kgf • cm)max
- ※ Mounting torque : M4:1.6N • m(16.9kgf • cm)max
- ※ Keep drawing current per pin below 20A for TB1.
- ※ Please connect safety ground to FG terminal on the unit.