

## ● PRODUCT INFORMATION ..... [Selection guide](#)



### High-attenuation type(2-Stage filter)(Single Phase)

Difference from old single phase 250V noise filters:

(1) Can select leakage current

(2) Push-down style terminal block prevents screw drop-out and cover loss

Can be used for many purposes.

❖ [Product Lineup](#)

| NBC |

❖ CATALOG DATA DOWN LOAD

❖ [Technical Data](#)

❖ [Specifications, circuit diagram and derating curve External view](#)

❖ [Characteristic data](#) • [Instruction manual](#) • [About noise filters](#)

**NBC Series : High-attenuation type of common mode noise from 150KHz to 1MHz(2-Stage filter)(single phase)**

#### • Features

- High attenuation type of common mode noise from 150kHz to 1MHz
- Single Phase 250 VAC
- Selectable leakage current
- Quick and easy push-down terminal  
Just connect the wires, push down and tighten the screws with a screwdriver
- DIN rail installation type(Optional)

#### • Safety agency approvals

- UL1283
- CSA C22.2 No.8 (C-UL)
- DIN EN60939 VDE0565 Teil 3-1
- ENEC

#### • Environment

- RoHS directive

#### • 5-year warranty

# NBC series

NBC -10 -472 -□

① ② ③ ④

- ① Model Name
- ② Rated Current
- ③ Line to ground capacitor code: See table 1.1.

table 1.1 Line to ground capacitor code

Code	Leakage Current (Input 125/250V 60Hz)	Line to ground capacitor (nominal value)
681	75.5 μA/ 150 μA max	680pF
102	0.13mA/ 0.25mA max	1000pF
222	0.25mA/ 0.5 mA max	2200pF
332	0.38mA/ 0.75mA max	3300pF
472	0.5 mA/ 1.0 mA max	4700pF

\* When the line to ground capacitor code is different, the attenuation characteristic is different.

- ④ Options
- D: DIN rail installation type

\* The dimensions change when the option is set. Refer to External view.

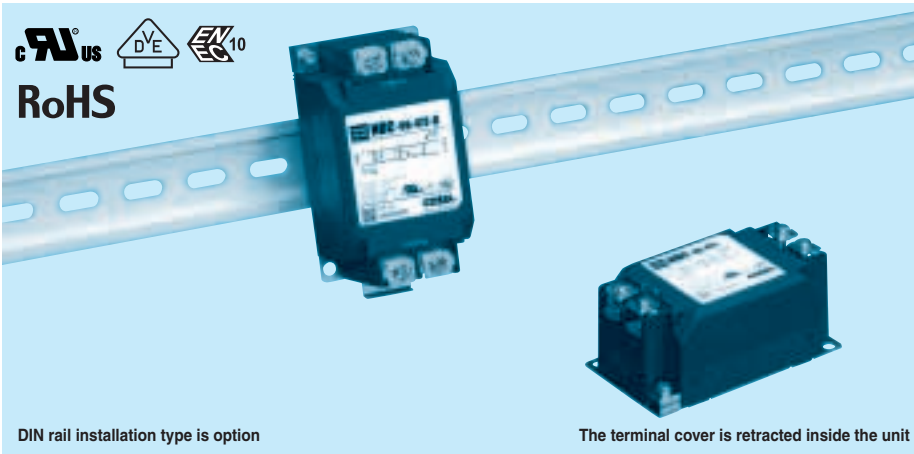

DIN rail installation type is option

The terminal cover is retracted inside the unit

## Features of NBC series

### High-attenuation type of common mode noise from 150kHz to 1MHz (2-stage filter)

· Single Phase 250 VAC

· Quick and easy push-down terminal

Just connect the wires, push down and tighten the screws with a screwdriver

## Specifications

No.	Items	NBC-06-472	NBC-10-472	NBC-16-472	NBC-20-472	NBC-30-472
1	Rated Voltage[V]	AC 1 φ 250 / DC250				
2	Rated Current[A]	6	10	16	20	30
3	Test Voltage (Terminal-Mounting Plate)	2,500 VAC (Cutoff Current = 20mA), 1minute at room temperature and humidity				
4	Isolation Resistance (Terminal-Mounting Plate)	500 VDC 100MΩ min at room temperature and humidity				
5	Leakage current 125/250V 60Hz	0.5mA/1.0mA max				
6	Voltage drop	1.0V max				
7	Safety agency approval temperatures	-25 to +85°C (Refer to Derating Curve)				
8	Operating temperature	-40 to +85°C (Refer to Derating Curve)				
9	Operating humidity	20 to 95%RH (Non condensing)				
10	Storage temperature/humidity	-40 to +85°C/20 to 95%RH (Non condensing)				
11	Vibration	10 to 55Hz, 19.6m/s <sup>2</sup> (2G), 3min. Period, 1hour each X, Y and Z axis				
12	Impact	196.1m/s <sup>2</sup> (20G), 11ms Once each X, Y and Z axis				
13	Safety agency approvals	UL1283, CSA C22.2 No.8 (C-UL), DIN EN60939 VDE0565 Teil3-1, ENEC (At only AC input)				
14	Case size (without projection) /Mass	53 × 41 × 92 mm (W × H × D) /270g max (Option : -D refer to external view)				

## Circuit Diagram

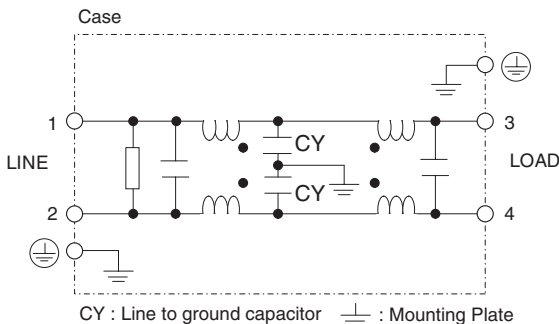

## Derating Curve

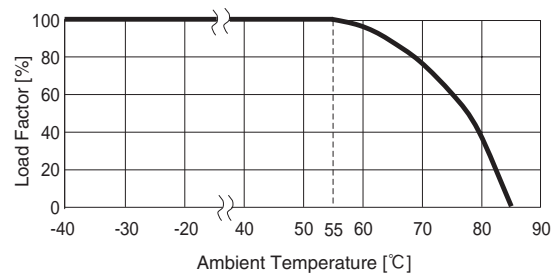

External view

This product is shipped in the following condition, because it is equipped with push-down terminals.

- ①The terminal cover is retracted inside the unit.
- ②The screws for connecting the terminals are held in the up right position.

Standard Type

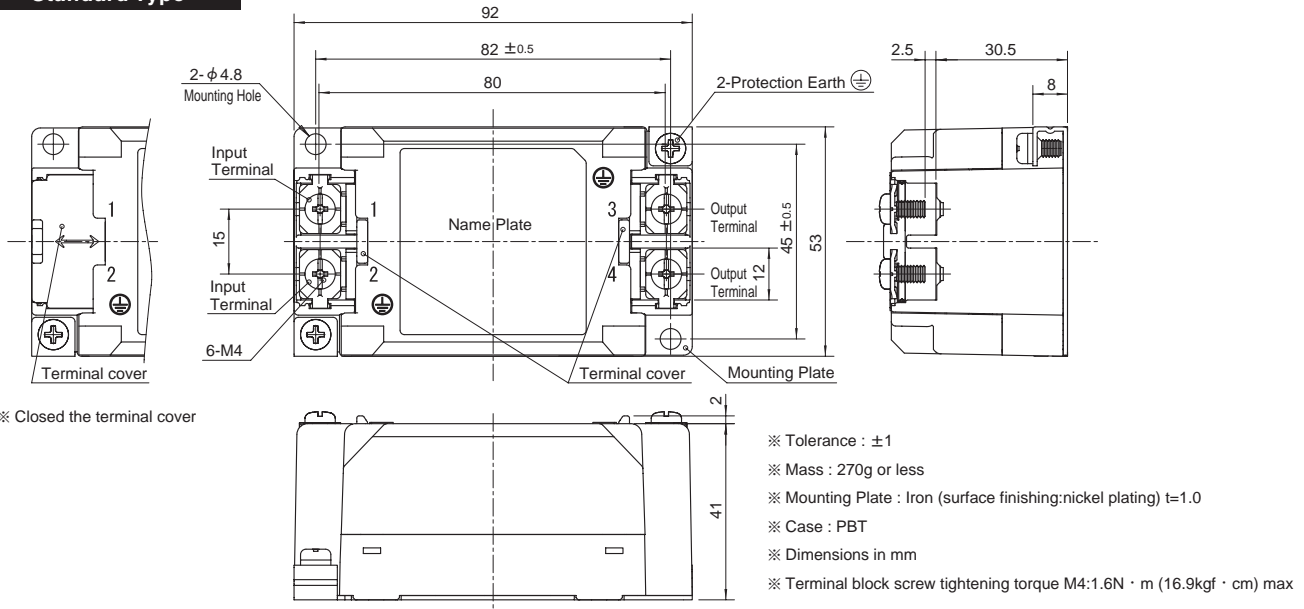

DIN rail installation Type

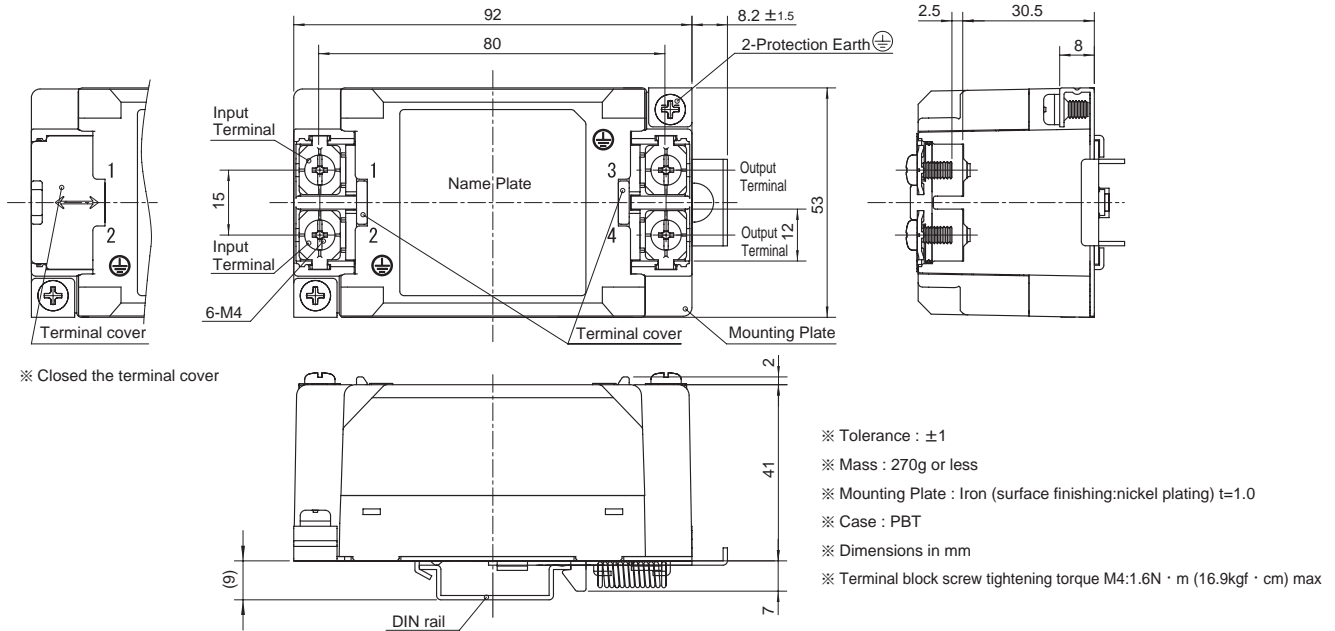

■Note when installing the noise filter on a DIN rail.

When the noise filter is grounded through the DIN rail, the proper noise attenuation may not be achieved.

Be sure to connect the protection earth (PE) of the noise filter body to the earth.

