

NAM



Features

- Single Phase 250 VAC
- Selectable leakage current
- Quick and easy push-down terminal. Just connect the wires, push down and tighten the screws with a screwdriver.
- DIN rail installation (option)
- Low leakage current type
- RoHS Compliant

Safety Agency Approvals

- UL1283
- CSA C22.2 No.8 (C-UL)
- DIN EN133200 VDE0565 Teil 3-1
- ENEC

Model	Rated Voltage [V]	Rated Current [A]
NAM-06-000	AC 1- 250 / DC250	6
NAM-10-000	AC 1- 250 / DC250	10
NAM-16-000	AC 1- 250 / DC250	16
NAM-20-000	AC 1- 250 / DC250	20
NAM-30-000	AC 1- 250 / DC250	30
NAM-04-000	AC 1- 250 / DC250	4

NAM series

NAM -10 -000 -□

① ② ③ ④

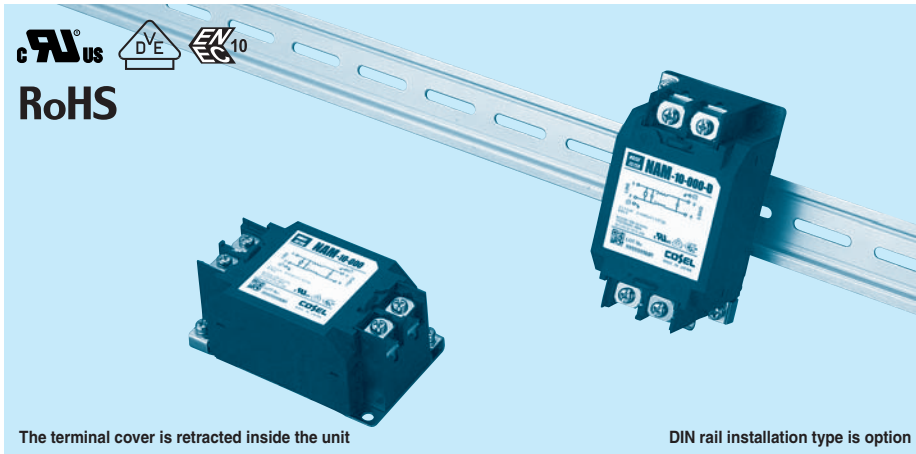

- ① Model Name
- ② Rated Current
- ③ Line to ground capacitor code: See table 1.1.

table.1.1 Line to ground capacitor code

Code	Leakage Current (Input 125/250V 60Hz)	Line to ground capacitor (nominal value)
000	5 μ A / 10 μ A max	Not Provided
101	12.5 μ A / 25 μ A max	100pF
221	25 μ A / 50 μ A max	220pF
331	37.5 μ A / 75 μ A max	330pF
471	50 μ A / 100 μ A max	470pF

*1 When the line to ground capacitor code is different, the attenuation characteristic is different.

- ④ Options
- D: DIN rail installation type

* The dimensions change when the option is set. Refer to External view.

Features of NAM series

Low leakage current type

· Single Phase 250 VAC

· Quick and easy push-down terminal

Just connect the wires, push down and tighten the screws with a screwdriver

Specifications

No.	Items	NAM-04-000	NAM-06-000	NAM-10-000	NAM-16-000	NAM-20-000	NAM-30-000
1	Rated Voltage[V]	AC 1 ϕ 250 / DC250					
2	Rated Current[A]	4	6	10	16	20	30
3	Test Voltage (Terminal-Mounting Plate)	2,500 VAC (Cutoff Current = 20mA), 1minute at room temperature and humidity					
4	Isolation Resistance (Terminal-Mounting Plate)	500 VDC 100M Ω minute at room temperature and humidity					
5	Leakage current 125/250V 60Hz	5 μ A/10 μ A max					
6	Voltage drop	1.0V max					
7	Safety agency approval temperatures	-25 to +85 $^{\circ}$ C (Refer to Derating Curve)					
8	Operating temperature	-40 to +85 $^{\circ}$ C (Refer to Derating Curve)					
9	Operating humidity	20 to 95%RH (Non condensing)					
10	Storage temperature/humidity	-40 to +85 $^{\circ}$ C/20 to 95%RH (Non condensing)					
11	Vibration	10 to 55Hz, 19.6m/s 2 (2G), 3min. Period, 1hour each X, Y and Z axis					
12	Impact	196.1m/s 2 (20G), 11ms Once each X, Y and Z axis					
13	Safety agency approvals	UL1283, CSA C22.2 No.8 (C-UL), DIN EN133200 VDE0565 Teil3-1, ENEC (At only AC input)					
14	Case size (without projection) /Mass	53 X 41 X 92 mm (W X H X D) /300g max (Option : -D refer to external view)					

Circuit Diagram

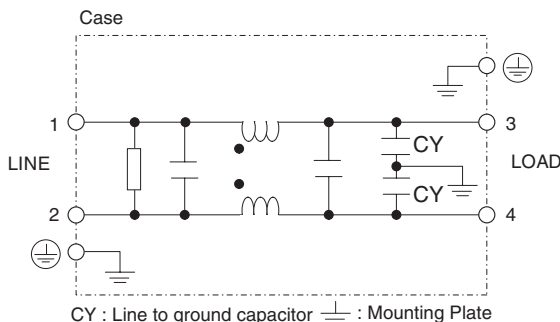

Derating Curve

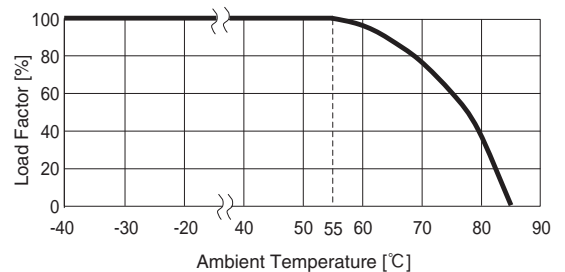

External view

This product is shipped in the following condition, because it is equipped with push-down terminals.

- ① The terminal cover is retracted inside the unit.
- ② The screws for connecting the terminals are held in the up right position.

Standard Type



DIN rail installation Type



■Note when installing the noise filter on a DIN rail.

When the noise filter is grounded through the DIN rail, the proper noise attenuation may not be achieved.

Be sure to connect the protection earth (PE) of the noise filter body to the earth.

