

**7511A85, 7511A62, 7511B11 Series Bright★Pipes™ Optical Lightpipes**

**DESCRIPTION AND FEATURES**

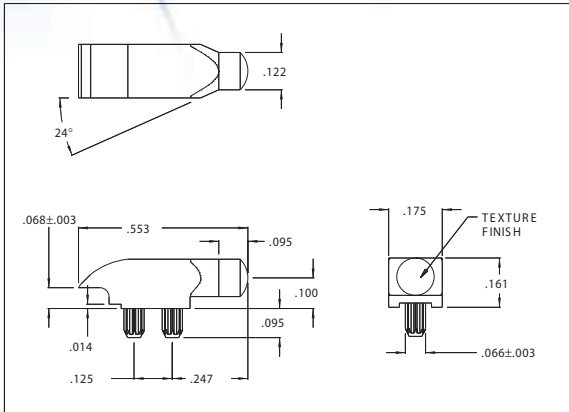

7511A85 / 7511A85V0

- Precision engineered with **ray tracing** for bright, optically precise even indication and attractive appearance.
- ESD protection from circuitry for exceptional reliability.
- Designed for use with Bright★Chips™ LEDs.
- High contrast and wide viewing angle for greater visibility.
- Available in a variety of colors for added contrast and aesthetics.
- Parts inserted after reflow to permit LED pad inspection before assembly.
- Available in UL94V-0
- Low profile for height constrained applications.
- Large lens provides high visibility.
- All 3 models have matching center lines to allow for side-by-side mounting.
- All dimensions in inches (mm).

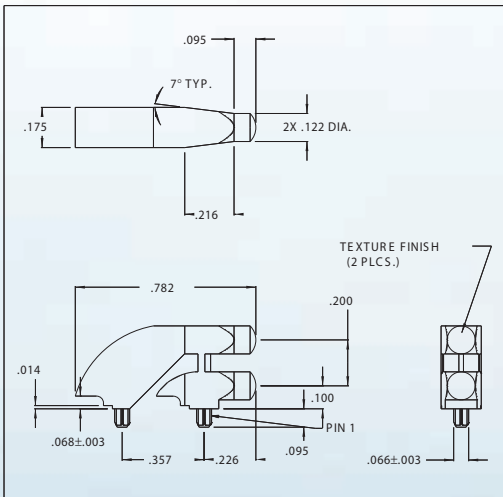

7511A62 / 7511A62V0

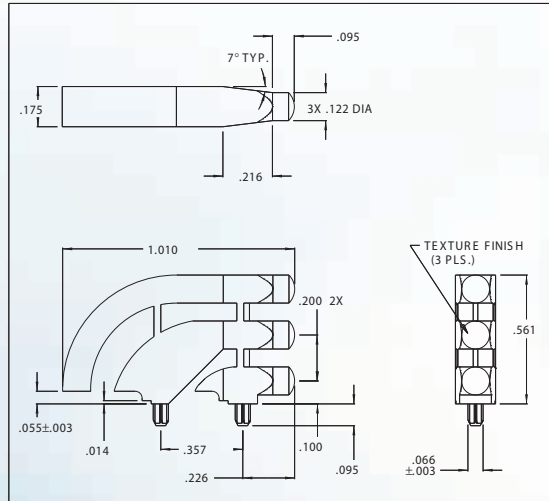

7511B11 / 7511B11V0