

CompactFlash™ Card

Wide Temperature Industrial CompactFlash 256MB

Lead-Free

Centon CompactFlash™ card is based on state-of-the-art NAND flash memory devices and a single-chip flash Hyperstone controller. The cards operate from a single power supply, either 5.0 V or 3.3 V. Capacities range 256MB.

Centon CompactFlash™ cards provide full IDE hard disk drive emulation and are fully compatible with the CompactFlash standard. It is the perfect choice of solid-state mass-storage cards for any Palmtop, notebook PC, PDA, handheld computer, Digital Camera, MP3 Player equipped with CompactFlash Card sockets.

Centon CompactFlash™ cards combine the reliability and ruggedness of flash media with high performance and low power requirements. A built-in error detection and correction mechanism in combination with a sophisticated wear-levelling algorithm improves reliability and increases the number of write cycles by order of magnitudes compared to other vendors.

CompactFlash™ 256MB

CF0116

Rev: 0.0 01/09

Block Diagram

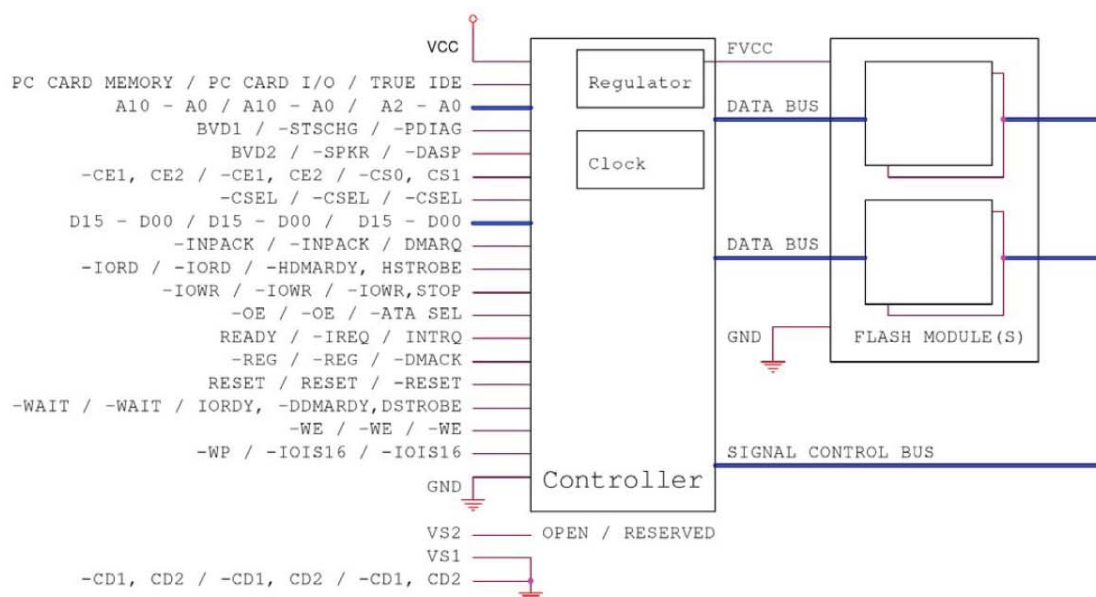

CompactFlash™ - 256MB

FEATURES

- * 256MB capacity, Fixed disk, SLC.
- * Single power supply (3.3V or 5.0V).
- * Endurance : 2,000,000 Program/Erase Cycles.
- * MTBF : 3,000,000 hours.
- * Support PIO Mode 0-6, Multiword DMA 4 and Ultra DMA 4.
- * Card Insertions/Removals : 10,000 times.
- * Sophisticated wear-levelling algorithm.
- * CompactFlash™ specification 3.0 version compliant.
- * Pin Count: 50pin connector type 1.
- * Data Reliability: < 1 non-recoverable error in 10¹⁴ bits read.
- * Low power consumption.
- * Support true IDE operation.
- * Compatible with host ATA disk I/O BIOS, Linux, DOS, XP, Vista.
- * Bad Blocks of flash memory will be replaced into new ones.
- * ECC function 4 bits per 512 byte, High Read/Write Speed.
- * Support Automatic Stand-by and Sleep Mode.
- * Type CompactFlash™ Card
42.8mm (1.7") x 36.4mm (1.4") x 3.3 mm (0.13")

COMPATIBILITY

Centon's CompactFlash™ card is fully compatible with the CompactFlash specification.

APPLICATION

Non-volatile storage solution for portable devices, such as PDAs, digital cameras and MP3 players

ENVIRONMENT

	OPERATING	STORAGE
TEMPERATURE	-40°C to 85°C	-55°C to 95°C
HUMIDITY	10% to 95%	10% to 95%

QUALITY

Very attractive quality compared to other vendors.

WARRANTY

Centon will repair or replace any Centon memory product that fails due to defective material or workmanship under normal use for the life of the product.

CF0116

Rev: 0.0 01/09

Pinout Information

PC Card Memory Mode				PC Card I/O Mode				True IDE Mode ⁴			
Pin Num	Signal Name	Pin Type	In, Out Type	Pin Num	Signal Name	Pin Type	In, Out Type	Pin Num	Signal Name	Pin Type	In, Out Type
1	GND		Ground	1	GND		Ground	1	GND		Ground
2	D03	I/O	I4Z,OZ1	2	D03	I/O	I4Z,OZ1	2	D03	I/O	I4Z,OZ1
3	D04	I/O	I4Z,OZ1	3	D04	I/O	I4Z,OZ1	3	D04	I/O	I4Z,OZ1
4	D05	I/O	I4Z,OZ1	4	D05	I/O	I4Z,OZ1	4	D05	I/O	I4Z,OZ1
5	D06	I/O	I4Z,OZ1	5	D06	I/O	I4Z,OZ1	5	D06	I/O	I4Z,OZ1
6	D07	I/O	I4Z,OZ1	6	D07	I/O	I4Z,OZ1	6	D07	I/O	I4Z,OZ1
7	-CE1	I	I3U	7	-CE1	I	I3U	7	-CE1	I	I3U
8	A10	I	I3Z	8	A10	I	I3Z	8	A10 ²	I	I3Z
9	-OE	I	I4U	9	-OE	I	I4U	9	-ATA SEL	I	I4U
10	A09	I	I3Z	10	A09	I	I3Z	10	A09 ²	I	I3Z
11	A08	I	I3Z	11	A08	I	I3Z	11	A08 ²	I	I3Z
12	A07	I	I3Z	12	A07	I	I3Z	12	A07 ²	I	I3Z
13	VCC		Power	13	VCC		Power	13	VCC		Power
14	A06	I	I3Z	14	A06	I	I3Z	14	A06 ²	I	I3Z
15	A05	I	I3Z	15	A05	I	I3Z	15	A05 ²	I	I3Z
16	A04	I	I3Z	16	A04	I	I3Z	16	A04 ²	I	I3Z
17	A03	I	I3Z	17	A03	I	I3Z	17	A03 ²	I	I3Z
18	A02	I	I3Z	18	A02	I	I3Z	18	A02	I	I3Z
19	A01	I	I3Z	19	A01	I	I3Z	19	A01	I	I3Z
20	A00	I	I3Z	20	A00	I	I3Z	20	A00	I	I3Z
21	D00	I/O	I4Z,OZ1	21	D00	I/O	I4Z,OZ1	21	D00	I/O	I4Z,OZ1
22	D01	I/O	I4Z,OZ1	22	D01	I/O	I4Z,OZ1	22	D01	I/O	I4Z,OZ1
23	D02	I/O	I4Z,OZ1	23	D02	I/O	I4Z,OZ1	23	D02	I/O	I4Z,OZ1
24	WP	O	OT1	24	-IOIS16	O	OT1	24	-IOCS16	O	ON1
25	-CD2	O	Ground	25	-CD2	O	Ground	25	-CD2	O	Ground
26	-CD1	O	Ground	26	-CD1	O	Ground	26	-CD1	O	Ground
27	D11 ¹	I/O	I4Z,OZ1	27	D11 ¹	I/O	I4Z,OZ1	27	D111	I/O	I4Z,OZ1
28	D12 ¹	I/O	I4Z,OZ1	28	D12 ¹	I/O	I4Z,OZ1	28	D121	I/O	I4Z,OZ1
29	D13 ¹	I/O	I4Z,OZ1	29	D13 ¹	I/O	I4Z,OZ1	29	D131	I/O	I4Z,OZ1
30	D14 ¹	I/O	I4Z,OZ1	30	D14 ¹	I/O	I4Z,OZ1	30	D141	I/O	I4Z,OZ1
31	D15 ¹	I/O	I4Z,OZ1	31	D15 ¹	I/O	I4Z,OZ1	31	D151	I/O	I4Z,OZ1
32	-CE2 ¹	I	I3U	32	-CE2 ¹	I	I3U	32	-CE2 ¹	I	I3U
33	-VS1	O	Ground	33	-VS1	O	Ground	33	-VS1	O	Ground
34	-IORD	I	I4U	34	-IORD	I	I4U	34	-IORD	I	I4U
35	-IOWR	I	I4U	35	-IOWR	I	I4U	35	-IOWR	I	I4U
36	-WE	I	I4U	36	-WE	I	I4U	36	-WE ³	I	I4U

CF0116

Rev: 0.0 01/09

PC Card Memory Mode				PC Card I/O Mode				True IDE Mode ⁴			
Pin Num	Signal Name	Pin Type	In, Out Type	Pin Num	Signal Name	Pin Type	In, Out Type	Pin Num	Signal Name	Pin Type	In, Out Type
37	RDY/BSY	O	OT1	37	-IREQ	O	OT1	37	INTRQ	O	OZ1
38	VCC		Power	38	VCC		Power	38	VCC		Power
39	-CSEL	I	I1U	39	-CSEL	I	I1U	39	-CSEL	I	I1U
40	-VS2	O	OPEN	40	-VS2	O	OPEN	40	-VS2	O	OPEN
41	RESET	I	I3U	41	RESET	I	I3U	41	-RESET	I	I3U
42	-WAIT	O	OT1	42	-WAIT	O	OT1	42	IORDY	O	ON1
43	-INPACK	O	OT1	43	-INPACK	O	OT1	43	DMARQ	O	OZ1
44	-REG	I	I3U	44	-REG	I	I3U	44	DMACK	I	I3U
45	BVD2	I/O	I4U,OT1	45	-SPKR	I/O	I4U,OT1	45	-DASP	I/O	I4U,ON1
46	BVD1	I/O	I4U,OT1	46	-STSCHG	I/O	I4U,OT1	46	-PDIAG	I/O	I4U,ON1
47	D08 ¹	I/O	I4Z,OZ1	47	D08 ¹	I/O	I4Z,OZ1	47	D08 ¹	I/O	I4Z,OZ1
48	D09 ¹	I/O	I4Z,OZ1	48	D09 ¹	I/O	I4Z,OZ1	48	D09 ¹	I/O	I4Z,OZ1
49	D10 ¹	I/O	I4Z,OZ1	49	D10 ¹	I/O	I4Z,OZ1	49	D10 ¹	I/O	I4Z,OZ1
50	GND		Ground	50	GND		Ground	50	GND		Ground

Note: 1. These signals are required only for 16 bit access and not required when installed in 8-bit systems. Devices should allow for 3-state signals not to consume current.

2. Should be grounded by the host.

3. Should be tied to Vcc by the host.

4. Option for CF+ Cards, required for CompactFlash Storage Cards.

* Pin 43 -INPACK (PC Card Memory Mode) This signal is not used in this mode. Should be connected at the host.

* Pin 43 -INPACK (PC Card I/O Mode) This signal is used by the host to control the enable of any input data buffers between the CompactFlash Storage Card and the CPU.

* Pin 43 DMARQ (True IDE Mode) This signal is asserted high when the card is ready to DMA data transfer.

* Pin 44 -REG (PC Card Memory Mode) This signal is used during Memory cycles to distinguish between Common Memory and Register (Attribute) Memory accesses.High for Common Memory, Low for Attribute Memory.

* Pin 44 -REG (PC Card I/O Mode) This signal must be also be active (low) during I/O Cycles when the I/O address is on the Bus.

* Pin 44 DMACK (True IDE Mode) This signal used for response to asserting DMARQ to initiate DMA transfer.

Absolute Maximum Rating

Parameter	Symbol	Rating		Unit
DC Power Supply Voltage	$V_{DD-V_{SS}}$	0.3	to 5.5	V
Input Voltage	V_{in}	$V_{SS}-0.3$	to $V_{DD}+0.3$	V
Operating Temperature	T_a	-40	to 85	C
Storage temperature	T_{STG}	-55	to 95	C

AC Characteristics (Attribute Memory Read AC Characteristics)

PARAMETER	Symbol	Min	Max	Note	Unit
Read cycle time	$t_{c(R)}$	300			ns
Address access time	$t_{A(A)}$		300		ns
CE access time	$t_{A(CE)}$		300		ns
OE access time	$t_{A(OE)}$		150		ns
Output disable time	$t_{DIS(CE)}$		100		ns
Output disable time	$t_{DIS(OE)}$		100		ns
Output enable time	$T_{EN(CE)}$	5			ns
Output enable time	$T_{EN(OE)}$	5			ns
Address setup time	$t_{SU(A)}$	30			ns

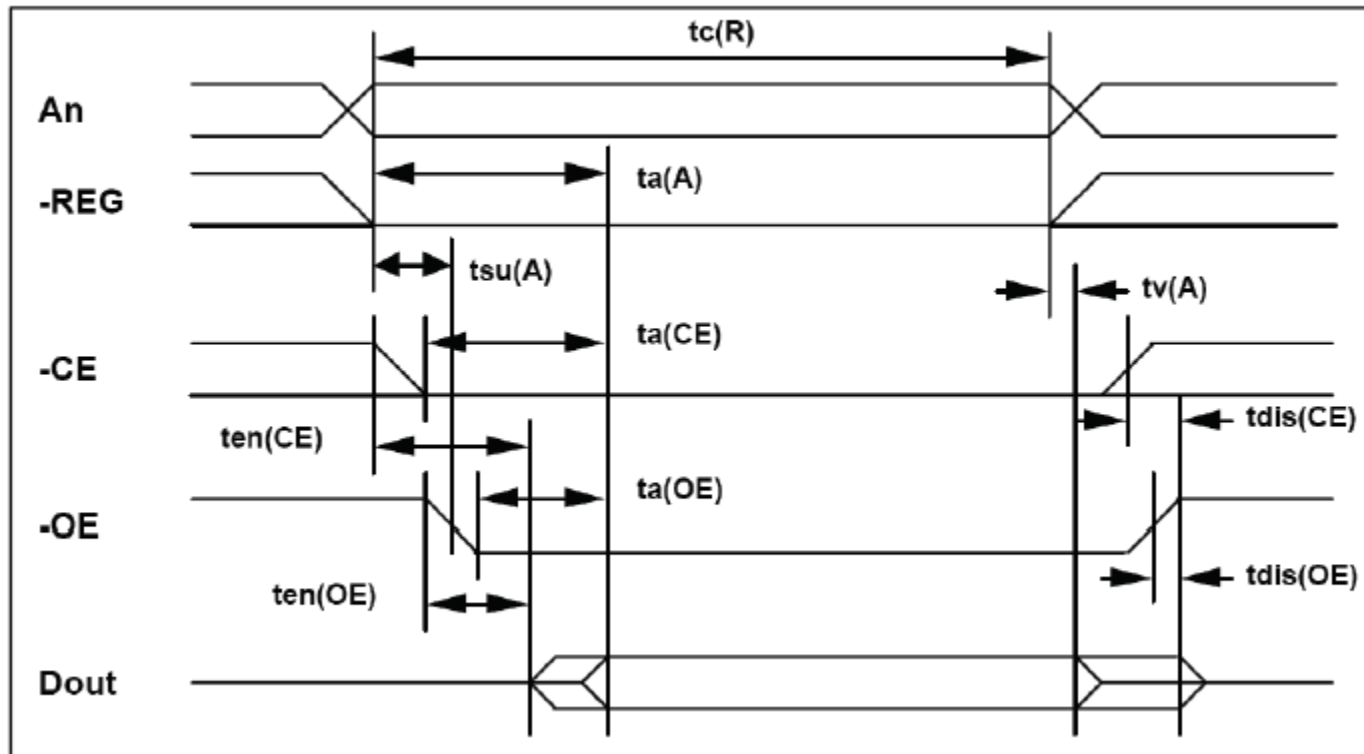

CF0116

Rev: 0.0 01/09

AC Characteristics (Attribute Memory write Timing)

PARAMETER	Symbol	Min	Max	Note	Unit
Write cycle time	t_{CW}	250			ns
Write pulse time	t_W	150			ns
Access setup time	$t_{SU(A)}$	30			ns
Data setup time (-WE)	$t_{SU(D-WE)}$	80			ns
Data hold time	$t_H(D)$	30			ns
Write recover time	$t_{REC(WE)}$	30			ns

Attribute Memory Write Timing

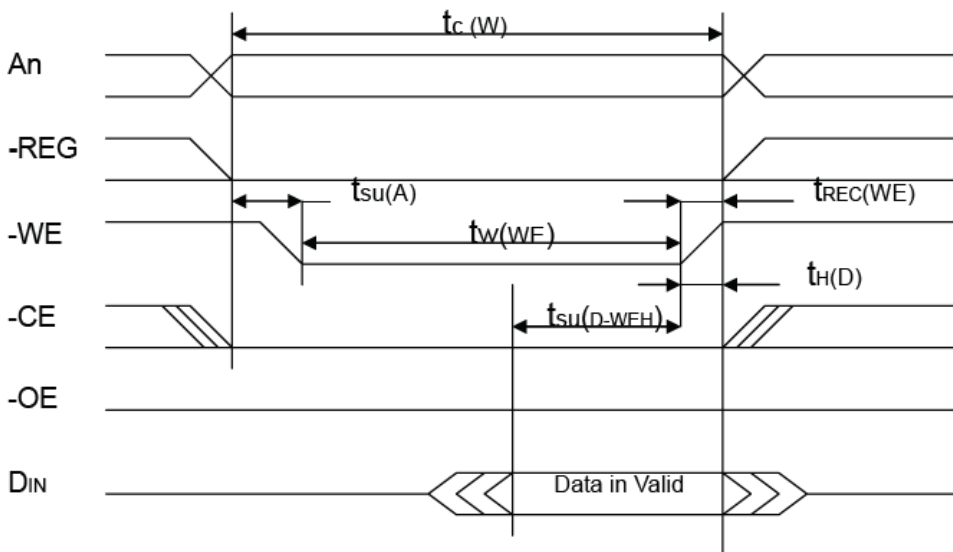

Product Specifications

Certifications:

FCC, CE.

Operating Voltage

3.3V / 5V +/-5-10%

Power Consumption (5V)

Read: 69mA

Write: 59mA

Power down mode: 1.2mA

Power Consumption (3.3V)

Read: 67mA

Write: 52mA

Power down mode: 0.7mA

Performance

Data Transfer Rate To/From Host: 18MB/sec burst.

Sequential write up to 10MB/s in ATA PIO Mode 4

Sequential read up to 20MB/s in ATA PIO Mode 4

ECC correction of 1 Byte random error per 128 Bytes of data

Start-up Time (Sleep to read/write) <10m sec

Altitude: 80,000ft max

Acoustic Noise: 0dB

Vibration: Operating/Non-Operating: 6Grms at frequency Range

3~2000Hz.

Shock: Operating/Non-Operating: 1000G Max.

Drop test: 1.5m free on P-title

Dimensions

Type I Card: 36.4mm(L) x 42.8mm(W) x 3.3mm(H)

Environment Conditions

Operating temperature: -40C to 85C

Storage temperature: -55C to 95C

CF0116

Rev: 0.0 01/09

Physical Dimensions

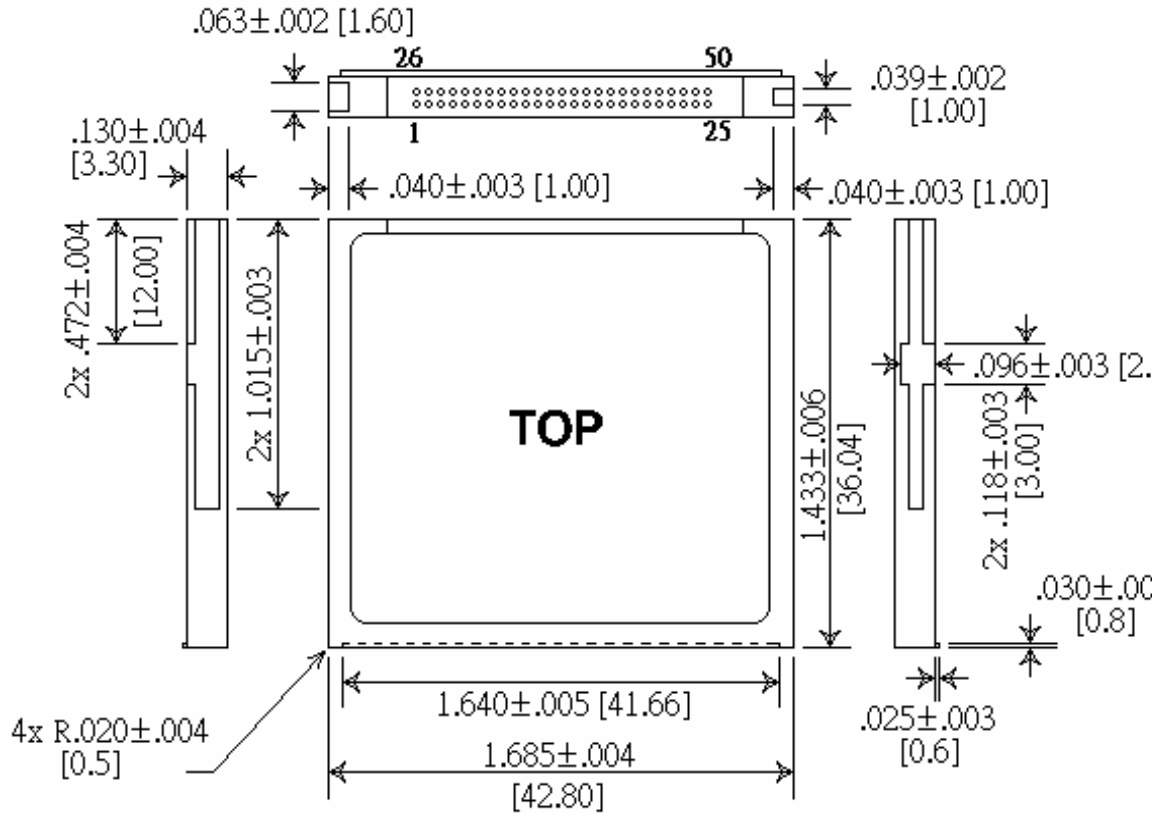

Length:	36.4±0.15mm(1.433±.006 in)
Width:	42.80±0.10mm(1.685±.004 in)
Thickness including label area:	3.3±0.10mm(.130±.004 in)



www.centon.com

CENTON NEW ENGLAND
 TEL: (800) 522-3191
 (800) 234-9292
 FAX: (978) 372-8971

CENTON NORTHEAST
 TEL: (631) 471-7700
 (800) 234-9292
 FAX: (631) 471-7717

CENTON SOUTHWEST
 TEL: (949) 855-9111
 (800) 234-9292
 FAX: (949) 855-3132