

ISS.	DATE	E.C.N.	DESCRIPTION
2	23-Apr-07	4/07/1202	TOLERANCE CORRECTIONS

© 2007 CARCLO
ALL DIMENSIONS IN mm

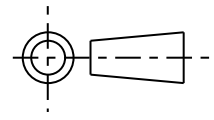

CARCLO TECHNICAL PLASTICS (SLOUGH)
111 BUCKINGHAM AVE, SLOUGH
SL1 4PF, ENGLAND
TEL: +44 1753 575011 FAX: +44 1753 811359
e-mail: design@carclo-optics.com}

CUSTOMER DRAWING

GENERAL TOLERANCES (UNLESS STATED)

LINEAR	ANGULAR
X +/- 0.25	X +/- 1°
X.X +/- 0.1	X.X +/- 0.5°
X.XX +/- 0.05	X.XX +/- 0.1°

CUSTOMER

CARCLO

TITLE

20MM DIA LED OPTIC HOLDER
FOR LUXEON REBEL

DRAWN

AJD

DATE

15-Feb-07

CHK'D

DATE

APP'D

DATE

SCALE

2:1

CARCLO PART No.

SEE TABLE

SIZE

A4

CARCLO DRG. No.

60459

SHEET

1 OF 1

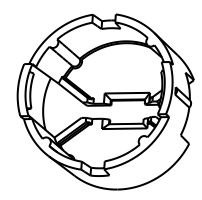
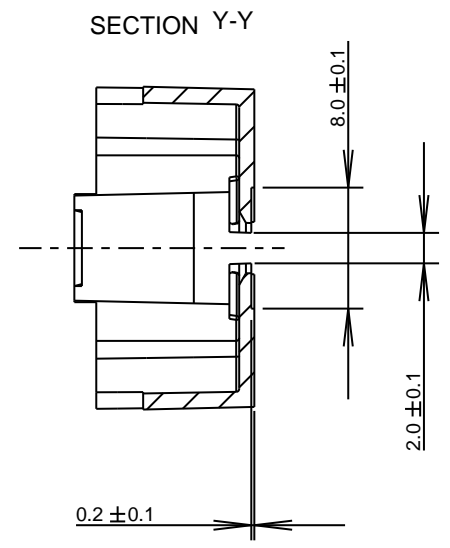
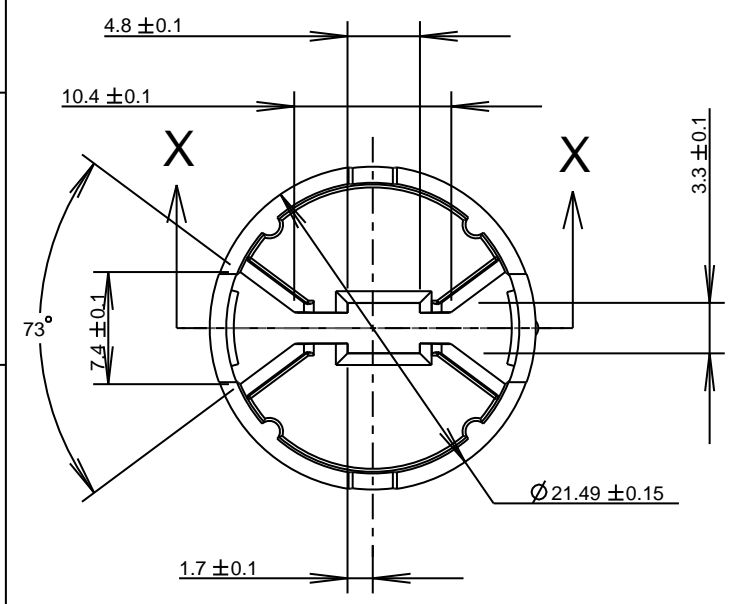

3D GENERAL VIEW
SCALE 1:1

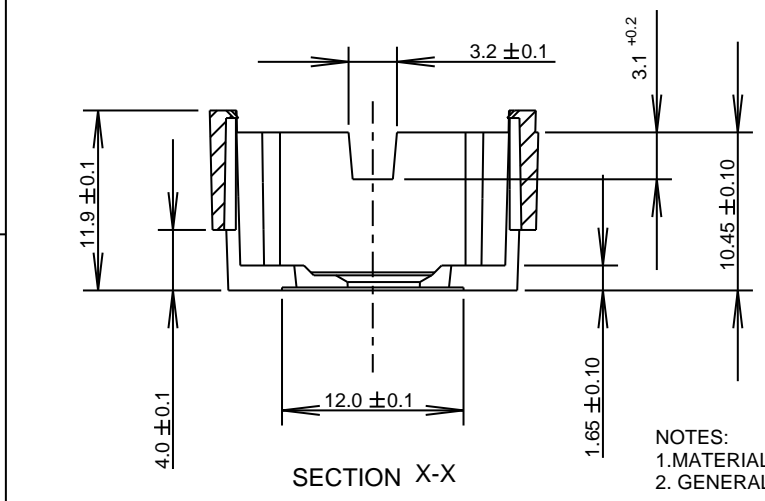

NOTES:
1. MATERIAL: POLYCARBONATE
2. GENERAL WALL THICKNESS 1mm

PART No.	DESCRIPTION
10235	BLACK
10236	WHITE
10237	CLEAR