



PS9552, PS9552L1, PS9552L2, PS9552L3

2.5 A OUTPUT CURRENT, HIGH CMR  
IGBT GATE DRIVE PHOTOCOUPLER  
8-PIN DIP PHOTOCOUPLER

-NEPOC Series-

**DESCRIPTION**

The PS9552, PS9552L1, PS9552L2 and PS9552L3 are optically coupled isolators containing a GaAlAs LED on the input side and a photo diode, a signal processing circuit and a power output transistor on the output side on one chip.

The PS9552 Series is designed specifically for high common mode transient immunity (CMR), high output current and high switching speed.

The PS9552 Series is suitable for driving IGBTs and MOS FETs.

The PS9552 Series is in a plastic DIP (Dual In-line Package).

The PS9552L1 is lead bending type for long creepage distance.

The PS9552L2 is lead bending type for long creepage distance (Gull-wing) for surface mount.

The PS9552L3 is lead bending type (Gull-wing) for surface mounting.

**FEATURES**

- <R> • Long creepage distance (8 mm MIN.: PS9552L1, PS9552L2)
- Large peak output current (2.5 A MAX., 2.0 A MIN.)
- High speed switching ( $t_{PLH}/t_{PHL} = 0.5 \mu s$  MAX.)
- UVLO (Under Voltage Lock Out) protection with hysteresis
- High common mode transient immunity ( $CM_H, CM_L = \pm 15 kV/\mu s$  MIN.)
- Ordering number of tape product: PS9552L2-E3: 1 000 pcs/reel  
: PS9552L3-E3: 1 000 pcs/reel
- Safety standards
  - UL approved: File No. E72422
  - CSA approved: No. CA 101391
  - BSI approved: No. 8937, 8938
  - SEMKO approved: No. 615433
  - NEMKO approved: No. P06207243
  - DEMKO approved: No. 314091
  - FIMKO approved: No. FI 22827
  - DIN EN60747-5-2 (VDE0884 Part2) approved (Option)

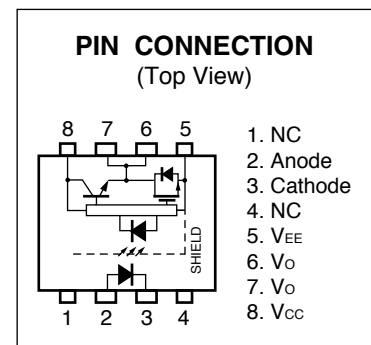

**APPLICATIONS**

- IGBT, Power MOS FET Gate Driver
- Industrial inverter
- IH (Induction Heating)

The information in this document is subject to change without notice. Before using this document, please confirm that this is the latest version.

**PACKAGE DIMENSIONS (UNIT: mm)**

**DIP Type**

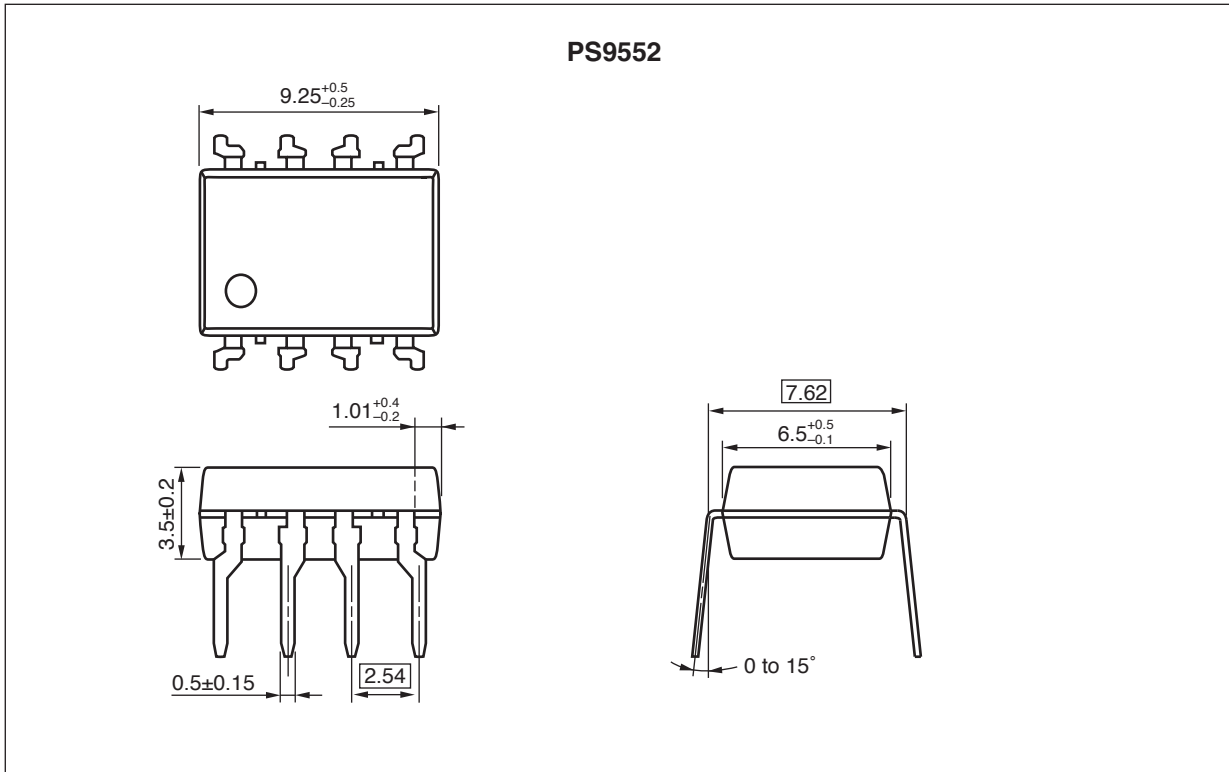

**Lead Bending Type (Gull-wing) For Surface Mount**

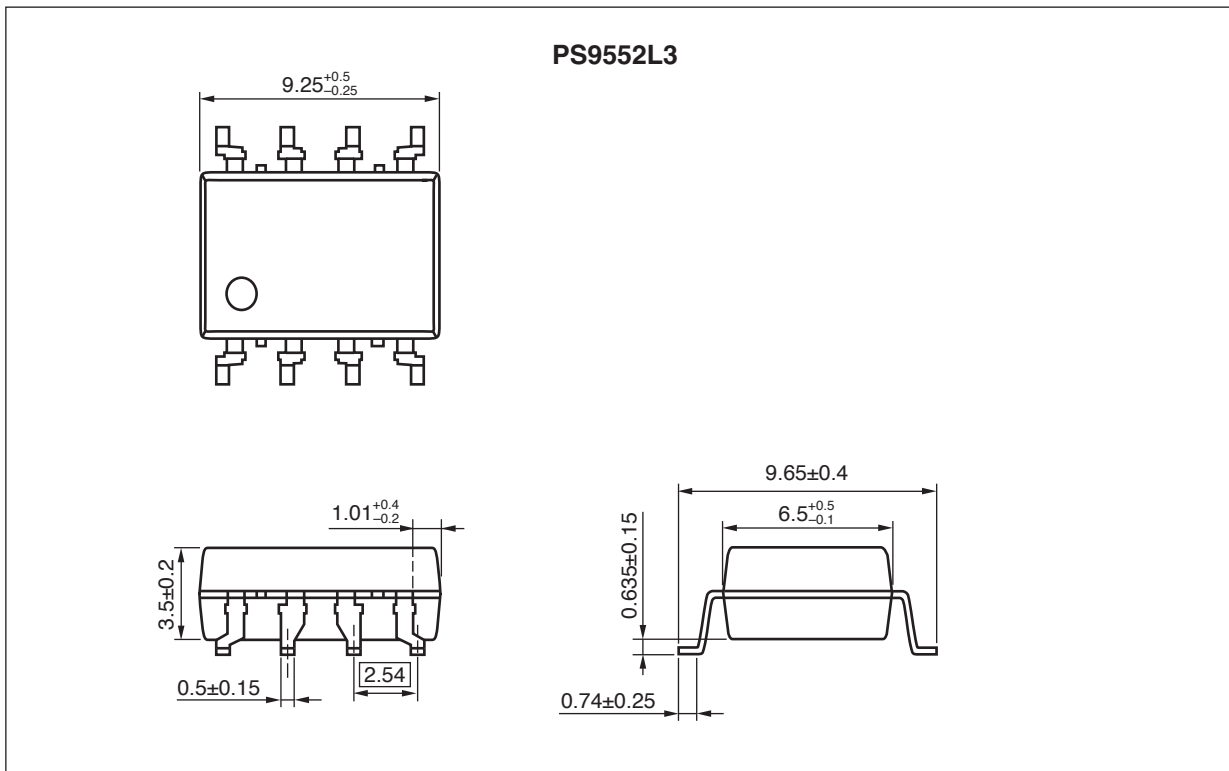

**Lead Bending Type For Long Creepage Distance**

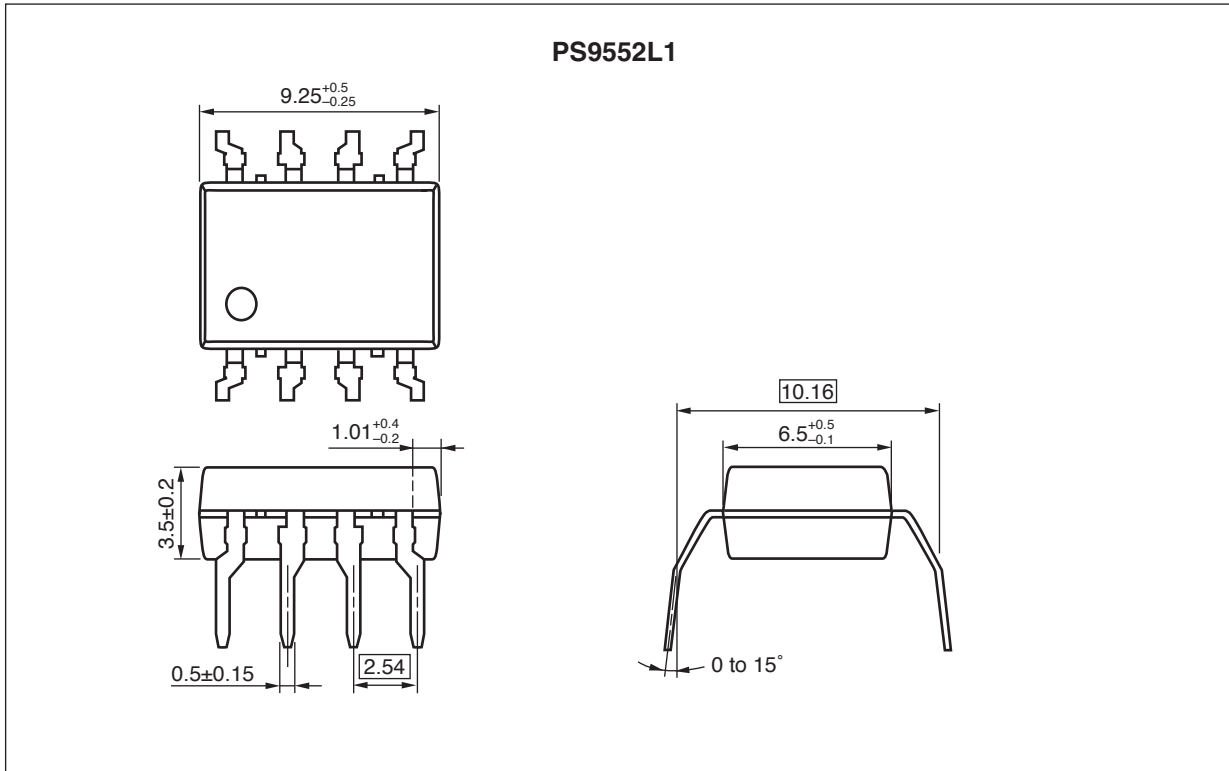

**Lead Bending Type (Gull-wing) For Long Creepage Distance (Surface Mount)**

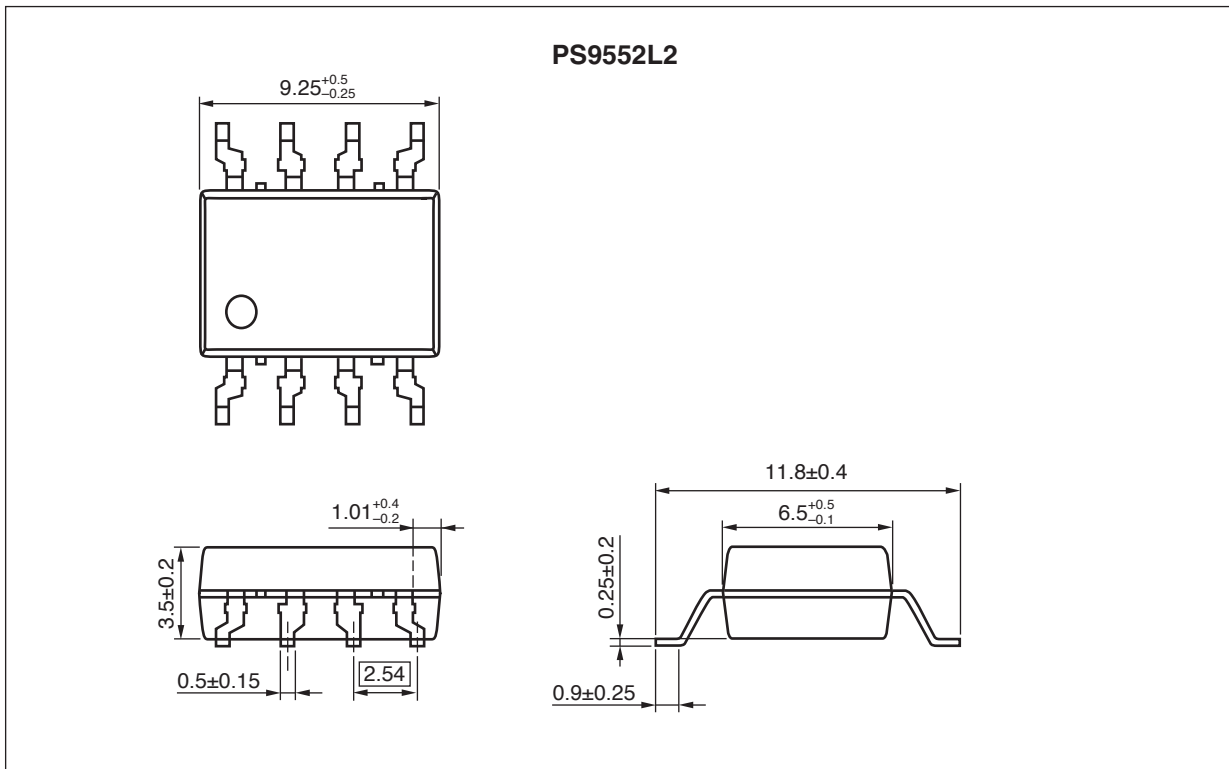

<R> FUNCTIONAL DIAGRAM

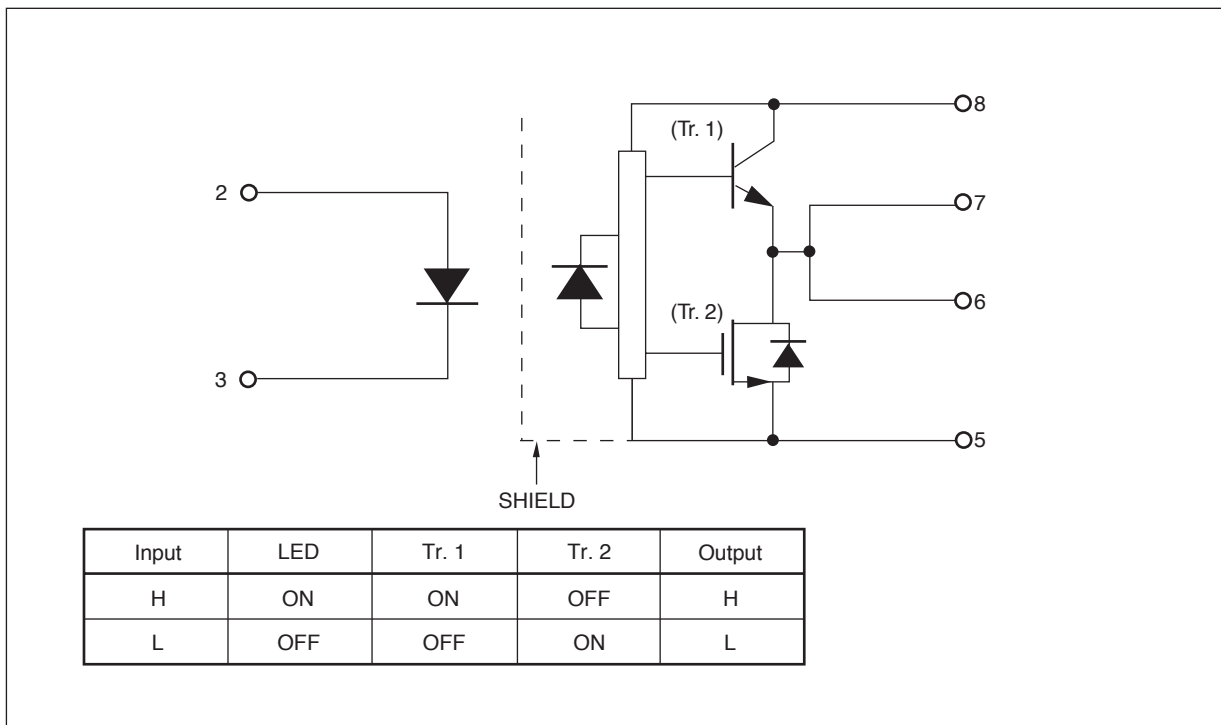

<R> MARKING EXAMPLE

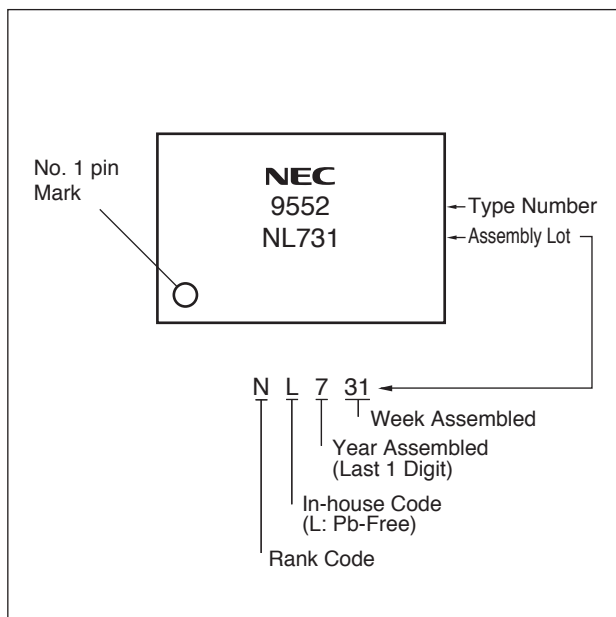

PHOTOCOUPLER CONSTRUCTION

Parameter	PS9552, PS9552L3	PS9552L1, PS9552L2
Air Distance (MIN.)	7 mm	8 mm
Outer Creepage Distance (MIN.)	7 mm	8 mm
Isolation Distance (MIN.)	0.4 mm	0.4 mm

<R> **ORDERING INFORMATION**

Part Number	Order Number	Solder Plating Specification	Packing Style	Safety Standard Approval	Application Part Number* <sup>1</sup>
PS9552	PS9552-AX	Pb-Free (Ni/Pd/Au)	Magazine case 50 pcs	Standard products (UL, CSA, BSI, SEMKO, NEMKO, DEMKO, FIMKO approved)	PS9552
PS9552L1	PS9552L1-AX				PS9552L1
PS9552L2	PS9552L2-AX				PS9552L2
PS9552L3	PS9552L3-AX				PS9552L3
PS9552L2-E3	PS9552L2-E3-AX		Embossed Tape 1 000 pcs/reel		PS9552L2
PS9552L3-E3	PS9552L3-E3-AX				PS9552L3
PS9552-V	PS9552-V-AX		Magazine case 50 pcs	DIN EN60747-5-2 (VDE0884 Part2) Approved (Option)	PS9552
PS9552L1-V	PS9552L1-V-AX				PS9552L1
PS9552L2-V	PS9552L2-V-AX				PS9552L2
PS9552L3-V	PS9552L3-V-AX				PS9552L3
PS9552L2-V-E3	PS9552L2-V-E3-AX		Embossed Tape 1 000 pcs/reel		PS9552L2
PS9552L3-V-E3	PS9552L3-V-E3-AX				PS9552L3

\*1 For the application of the Safety Standard, following part number should be used.

**ABSOLUTE MAXIMUM RATINGS (T<sub>A</sub> = 25°C, unless otherwise specified)**

Parameter		Symbol	Ratings	Unit
Diode	Forward Current	I <sub>F</sub>	25	mA
	Peak Transient Forward Current (Pulse Width < 1 μs)	I <sub>F (TRAN)</sub>	1.0	A
	Reverse Voltage	V <sub>R</sub>	5	V
Detector	High Level Peak Output Current <sup>*1</sup>	I <sub>OH (PEAK)</sub>	2.5	A
	Low Level Peak Output Current <sup>*1</sup>	I <sub>OL (PEAK)</sub>	2.5	A
	Supply Voltage	(V <sub>CC</sub> - V <sub>EE</sub> )	0 to 35	V
	Output Voltage	V <sub>O</sub>	0 to V <sub>CC</sub>	V
	Power Dissipation <sup>*2</sup>	P <sub>C</sub>	250	mW
Isolation Voltage <sup>*3</sup>		BV	5 000	Vr.m.s.
Total Power Dissipation <sup>*4</sup>		P <sub>T</sub>	300	mW
Operating Frequency <sup>*5</sup>		f	50	kHz
Operating Ambient Temperature		T <sub>A</sub>	-40 to +100	°C
Storage Temperature		T <sub>stg</sub>	-55 to +125	°C

\*1 Maximum pulse width = 10 μs, Maximum duty cycle = 0.2%

<R> \*2 Reduced to 4.8 mW/°C at T<sub>A</sub> = 70°C or more.

\*3 AC voltage for 1 minute at T<sub>A</sub> = 25°C, RH = 60% between input and output.  
Pins 1-4 shorted together, 5-8 shorted together.

<R> \*4 Reduced to 5.4 mW/°C at T<sub>A</sub> = 70°C or more.

\*5 I<sub>OH (PEAK)</sub> ≤ 2.0 A (≤ 0.3 μs), I<sub>OL (PEAK)</sub> ≤ 2.0 A (≤ 0.3 μs)

**RECOMMENDED OPERATING CONDITIONS**

Parameter	Symbol	MIN.	TYP.	MAX.	Unit
Supply Voltage	(V <sub>CC</sub> - V <sub>EE</sub> )	15		30	V
Forward Current (ON)	I <sub>F (ON)</sub>	7	10	16	mA
Forward Voltage (OFF)	V <sub>F (OFF)</sub>	-2		0.8	V
Operating Ambient Temperature	T <sub>A</sub>	-40		100	°C

**ELECTRICAL CHARACTERISTICS** ( $T_A = -40$  to  $+100^\circ\text{C}$ ,  $V_{CC} = 15$  to  $30$  V,  $I_F(\text{ON}) = 7$  to  $16$  mA,  $V_F(\text{OFF}) = -2$  to  $0.8$  V,  $V_{EE} = \text{GND}$ , unless otherwise specified)

Parameter		Symbol	Conditions	MIN.	TYP.*1	MAX.	Unit
Diode	Forward Voltage	$V_F$	$I_F = 10$ mA, $T_A = 25^\circ\text{C}$	1.3	1.65	2.1	V
	Input Capacitance	$C_{IN}$	$f = 1$ MHz, $V_F = 0$ V, $T_A = 25^\circ\text{C}$		60		pF
<R>	High Level Output Current	$I_{OH}$	$V_O = (V_{CC} - 4 \text{ V})^{*2}$	0.5	2.0		A
			$V_O = (V_{CC} - 15 \text{ V})^{*3}$	2.0			
	Low Level Output Current	$I_{OL}$	$V_O = (V_{EE} + 2.5 \text{ V})^{*2}$	0.5	2.0		A
			$V_O = (V_{EE} + 15 \text{ V})^{*3}$	2.0			
	High Level Output Voltage	$V_{OH}$	$I_O = -100$ mA <sup>*4</sup>	$V_{CC} - 3.5$	$V_{CC} - 2.5$	$V_{CC} - 1.5$	V
	Low Level Output Voltage	$V_{OL}$	$I_O = 100$ mA		0.1	0.5	V
	High Level Supply Current	$I_{CCH}$	$V_O = \text{open}$ , $I_F = 7$ to $16$ mA		2.0	5.0	mA
	Low Level Supply Current	$I_{CCL}$	$V_O = \text{open}$ , $V_F = -2$ to $+0.8$ V		2.0	5.0	mA
	UVLO Threshold	$V_{UVLO+}$	$V_O > 5$ V, $I_F = 10$ mA	11.0	12.3	13.5	V
		$V_{UVLO-}$		9.5	10.7	12.0	
UVLO Hysteresis	$UVLO_{HYS}$	$V_O > 5$ V, $I_F = 10$ mA		1.6		V	
<R>	Threshold Input Current (L → H)	$I_{FLH}$	$I_O = 0$ mA, $V_O > 5$ V		2.0	5.0	mA
	Threshold Input Voltage (H → L)	$V_{FHL}$	$I_O = 0$ mA, $V_O < 5$ V	0.8			V

\*1 Typical values at  $T_A = 25^\circ\text{C}$ .

\*2 Maximum pulse width = 50  $\mu\text{s}$ , Maximum duty cycle = 0.5%.

\*3 Maximum pulse width = 10  $\mu\text{s}$ , Maximum duty cycle = 0.2%

\*4  $V_{OH}$  is measured with the DC load current in this testing (Maximum pulse width = 2 ms, Maximum duty cycle = 20%).

**SWITCHING CHARACTERISTICS** ( $T_A = -40$  to  $+100^\circ\text{C}$ ,  $V_{CC} = 15$  to  $30$  V,  $I_F(\text{ON}) = 7$  to  $16$  mA,  $V_F(\text{OFF}) = -2$  to  $0.8$  V,  $V_{EE} = \text{GND}$ , unless otherwise specified)

Parameter	Symbol	Conditions	MIN.	TYP.*1	MAX.	Unit
Propagation Delay Time (L → H)	$t_{PLH}$	$R_g = 10 \Omega$ , $C_g = 10 \text{ nF}$ , $f = 10 \text{ kHz}$ , Duty Cycle = 50%*2	0.1	0.3	0.5	$\mu\text{s}$
Propagation Delay Time (H → L)	$t_{PHL}$		0.1	0.3	0.5	$\mu\text{s}$
Pulse Width Distortion (PWD)	$ t_{PHL} - t_{PLH} $				0.3	$\mu\text{s}$
Propagation Delay Time (Difference Between Any Two Products)	$t_{PHL} - t_{PLH}$		-0.35		0.35	$\mu\text{s}$
Rise Time	$t_r$			0.1		$\mu\text{s}$
Fall Time	$t_f$			0.1		$\mu\text{s}$
UVLO (Turn On Delay)	$t_{UVLO \text{ ON}}$		$V_O > 5 \text{ V}$ , $I_F = 10 \text{ mA}$		0.8	
UVLO (Turn Off Delay)	$t_{UVLO \text{ OFF}}$	$V_O < 5 \text{ V}$ , $I_F = 10 \text{ mA}$		0.6		$\mu\text{s}$
Common Mode Transient Immunity at High Level Output*3	$CM_H$	$T_A = 25^\circ\text{C}$ , $I_F = 10 \text{ mA}$ , $V_{O(\text{MIN.})} = 26 \text{ V}$ , $V_{CM} = 1.5\text{k V}$	15			$\text{kV}/\mu\text{s}$
Common Mode Transient Immunity at Low Level Output*3	$CM_L$	$T_A = 25^\circ\text{C}$ , $I_F = 0 \text{ mA}$ , $V_{O(\text{MAX.})} = 1 \text{ V}$ , $V_{CM} = 1.5\text{k V}$	15			$\text{kV}/\mu\text{s}$

\*1 Typical values at  $T_A = 25^\circ\text{C}$ .

\*2 This load condition is equivalent to the IGBT load at 1 200 V/75 A.

\*3 Connect pin 1 and pin 4 to the LED common.



TEST CIRCUIT

Fig. 1 I<sub>OH</sub> Test Circuit

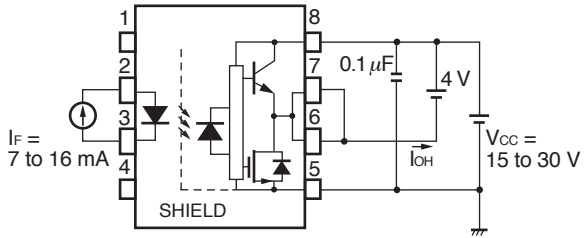

Fig. 2 I<sub>OL</sub> Test Circuit

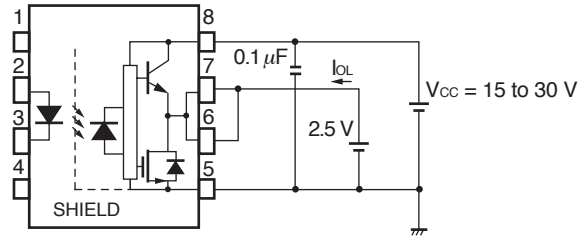

Fig. 3 V<sub>OH</sub> Test Circuit

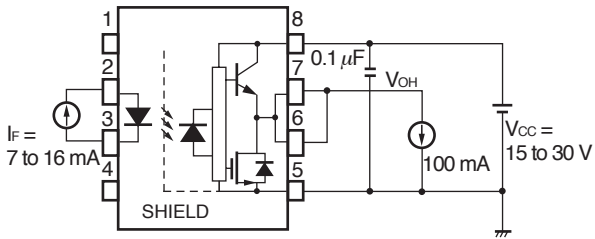

Fig. 4 V<sub>OL</sub> Test Circuit

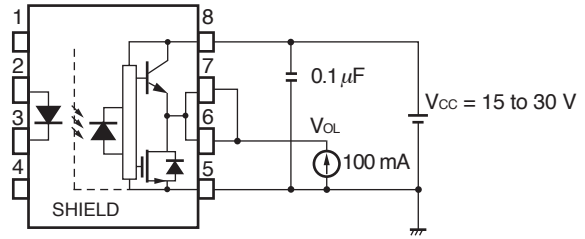

Fig. 5 I<sub>FLH</sub> Test Circuit

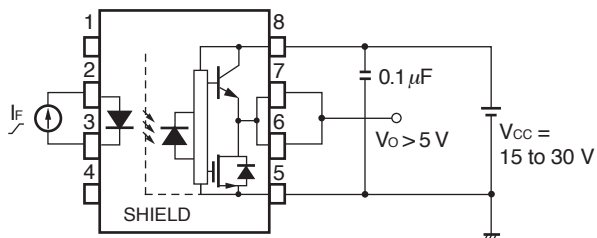

Fig. 6 UVLO Test Circuit

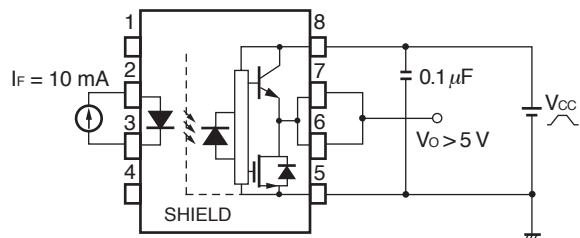

Fig. 7  $t_{PLH}$ ,  $t_{PHL}$ ,  $t_r$ ,  $t_f$  Test Circuit and Wave Forms

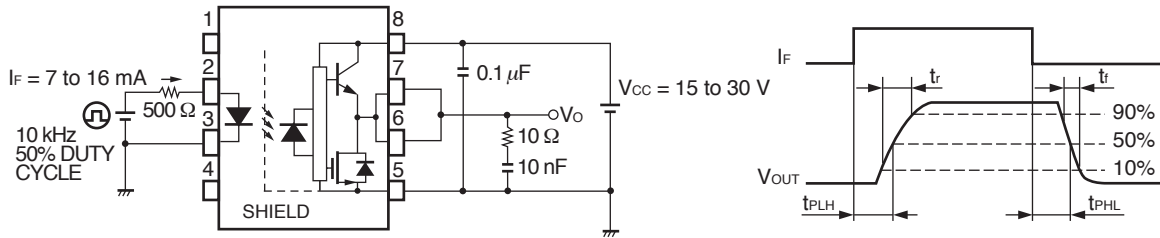
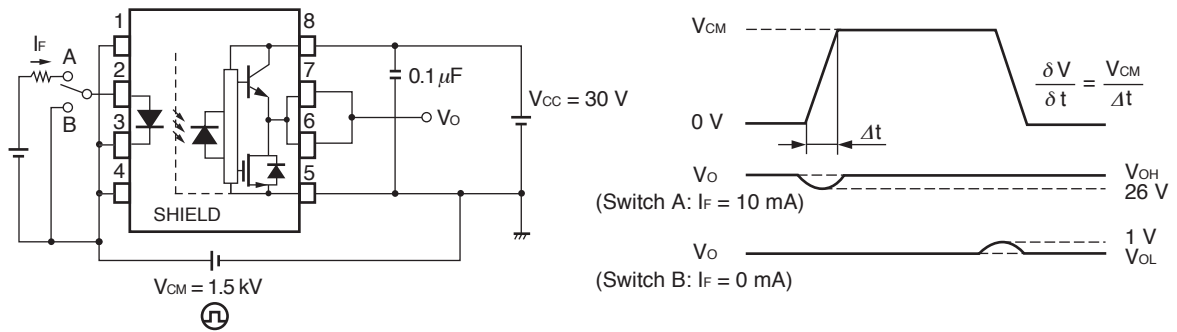

Fig. 8 CMR Test Circuit and Wave Forms



**Remark** CMR Test : Connect pin 1 and pin 4 to the LED common.

<R> **TYPICAL CHARACTERISTICS (TA = 25°C, unless otherwise specified)**

**MAXIMUM FORWARD CURRENT vs. AMBIENT TEMPERATURE**

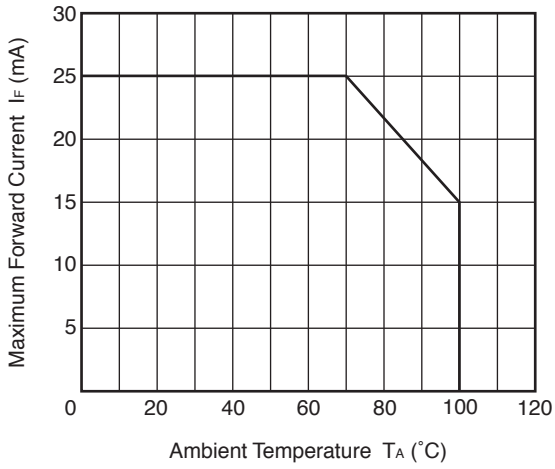

**DETECTOR POWER DISSIPATION vs. AMBIENT TEMPERATURE**

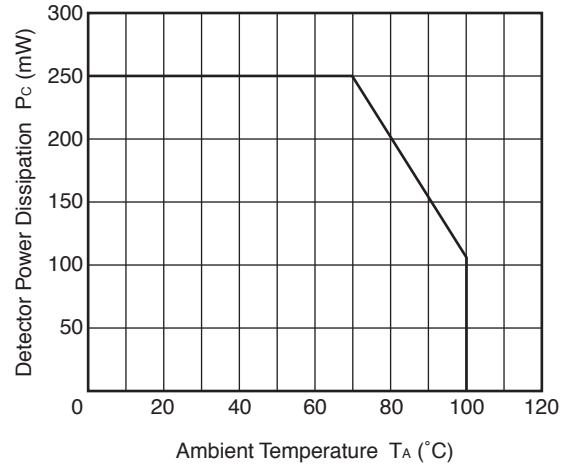

**TOTAL POWER DISSIPATION vs. AMBIENT TEMPERATURE**

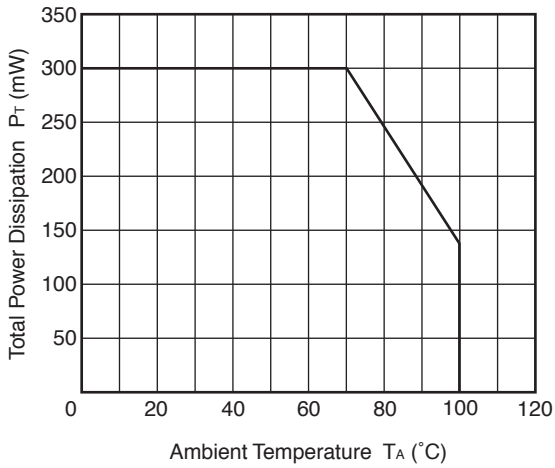

**FORWARD CURRENT vs. FORWARD VOLTAGE**

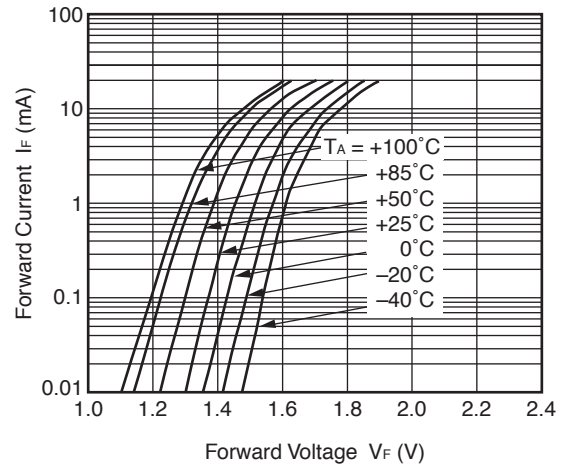

**THRESHOLD INPUT CURRENT vs. AMBIENT TEMPERATURE**

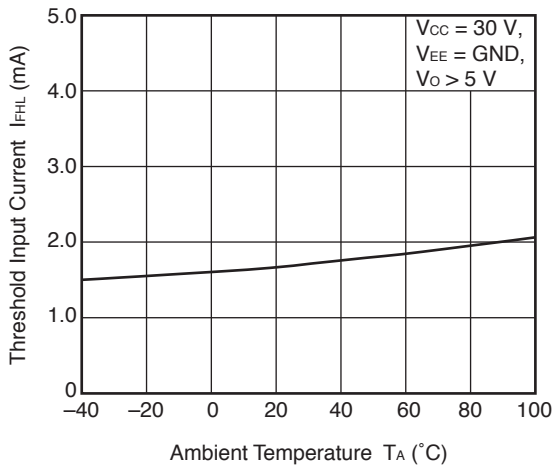

**OUTPUT VOLTAGE vs. FORWARD CURRENT**

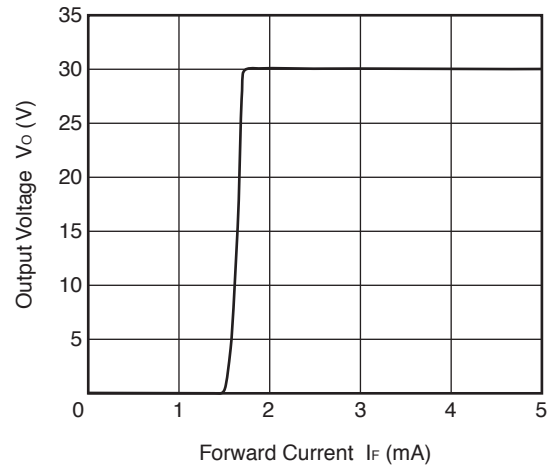

**Remark** The graphs indicate nominal characteristics.

HIGH LEVEL OUTPUT VOLTAGE – SUPPLY VOLTAGE vs. HIGH LEVEL OUTPUT CURRENT

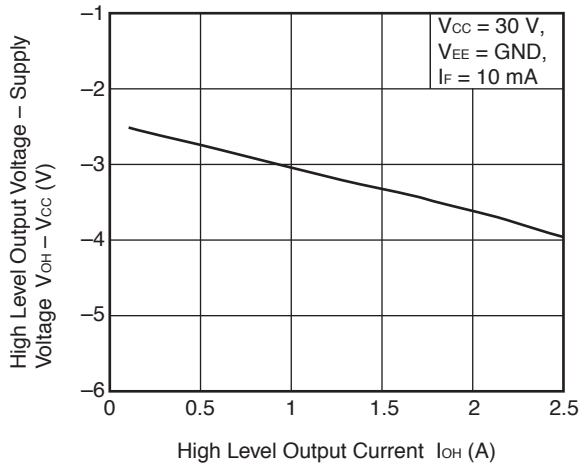

LOW LEVEL OUTPUT VOLTAGE vs. LOW LEVEL OUTPUT CURRENT

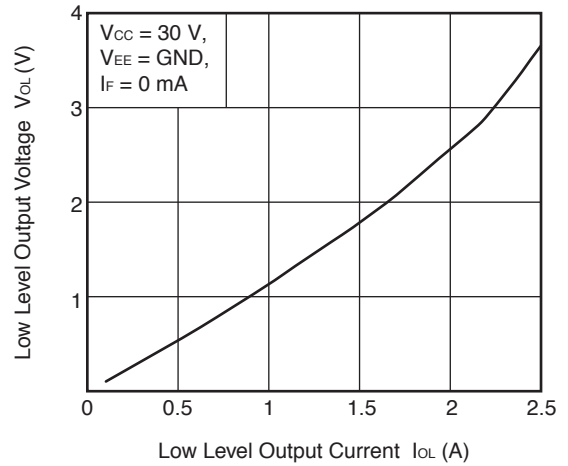

PROPAGATION DELAY TIME, PULSE WIDTH DISTORTION vs. FORWARD CURRENT

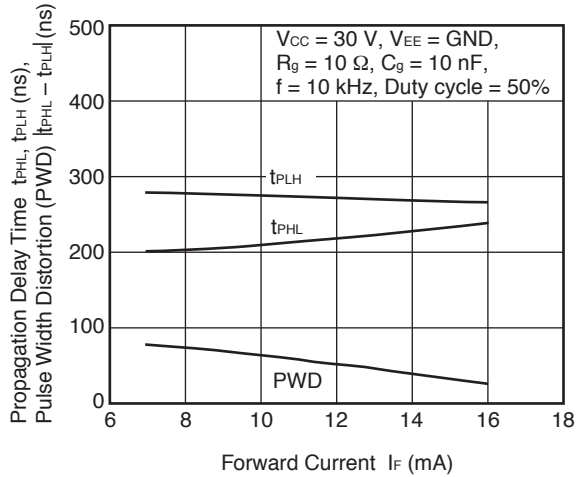

PROPAGATION DELAY TIME, PULSE WIDTH DISTORTION vs. SUPPLY VOLTAGE

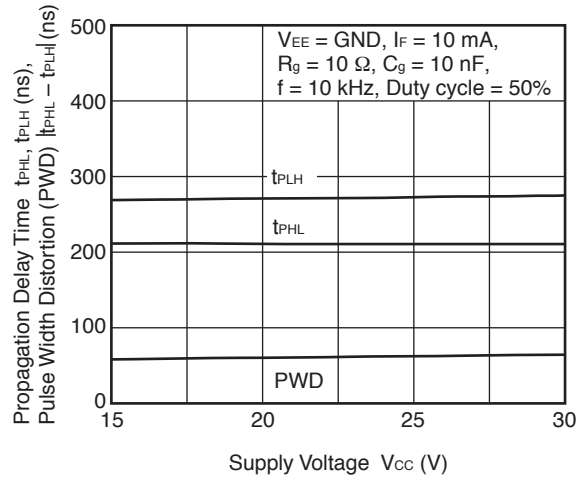

PROPAGATION DELAY TIME, PULSE WIDTH DISTORTION vs. AMBIENT TEMPERATURE

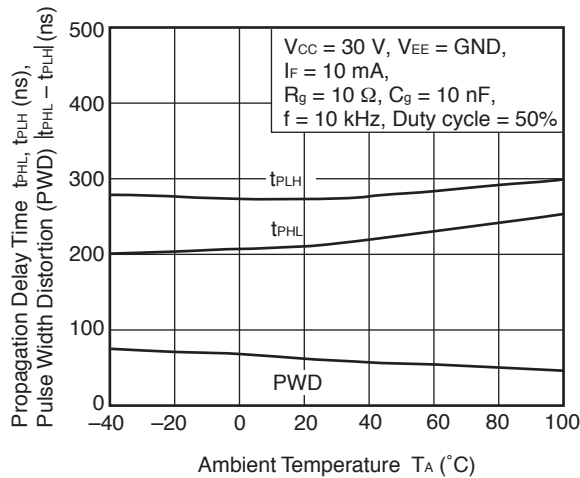

PROPAGATION DELAY TIME, PULSE WIDTH DISTORTION vs. LOAD CAPACITANCE

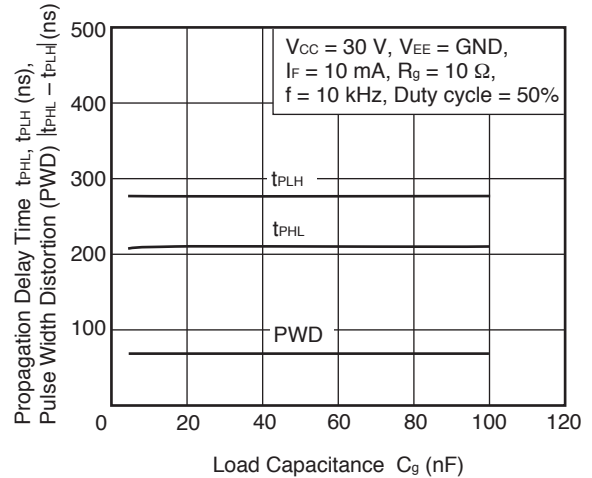

**Remark** The graphs indicate nominal characteristics.

SUPPLY CURRENT vs. AMBIENT TEMPERATURE

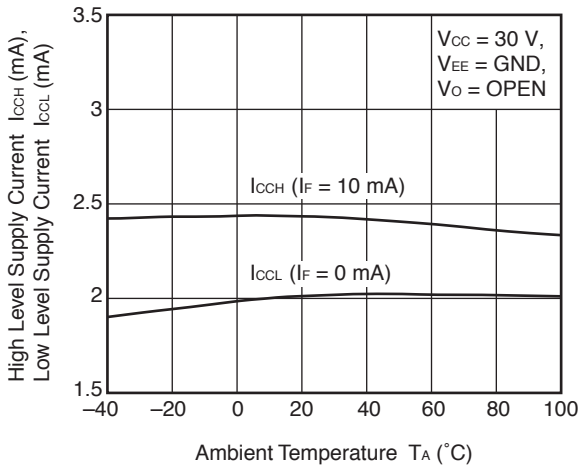

SUPPLY CURRENT vs. AMBIENT TEMPERATURE

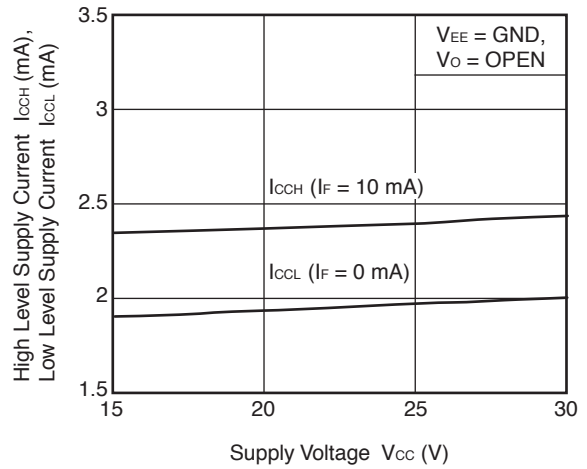

HIGH LEVEL OUTPUT VOLTAGE – SUPPLY VOLTAGE vs. AMBIENT TEMPERATURE

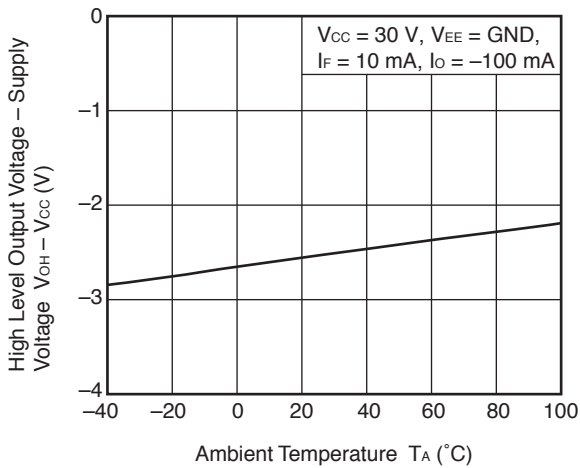

LOW LEVEL OUTPUT VOLTAGE vs. AMBIENT TEMPERATURE

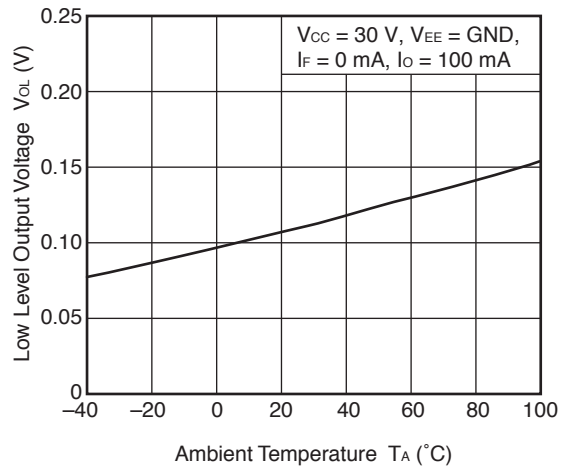

HIGH LEVEL OUTPUT CURRENT vs. AMBIENT TEMPERATURE

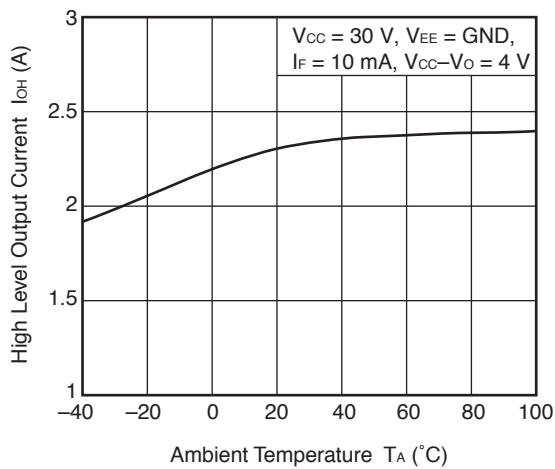

LOW LEVEL OUTPUT CURRENT vs. AMBIENT TEMPERATURE

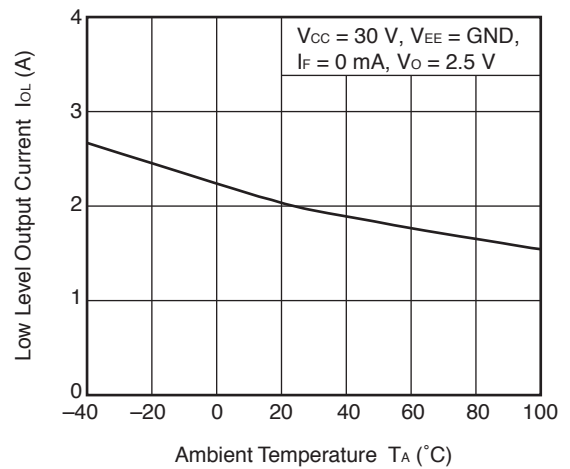

**Remark** The graphs indicate nominal characteristics.

PROPAGATION DELAY TIME,  
PULSE WIDTH DISTORTION  
vs. LOAD RESISTANCE

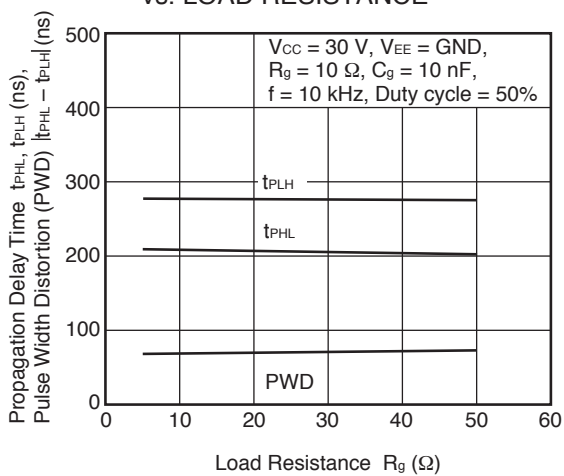

OUTPUT VOLTAGE vs. SUPPLY VOLTAGE

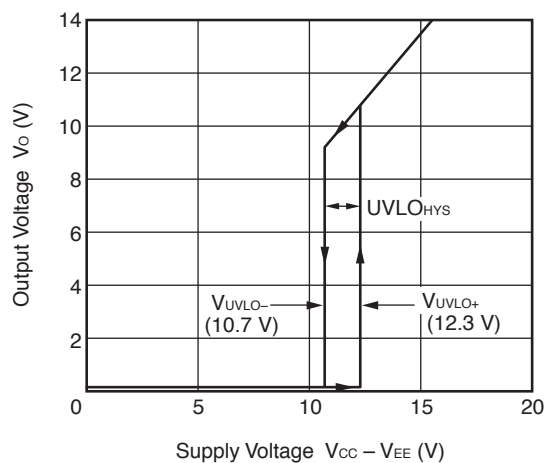

**Remark** The graphs indicate nominal characteristics.

<R> TAPING SPECIFICATIONS (UNIT: mm)

Outline and Dimensions (Tape)

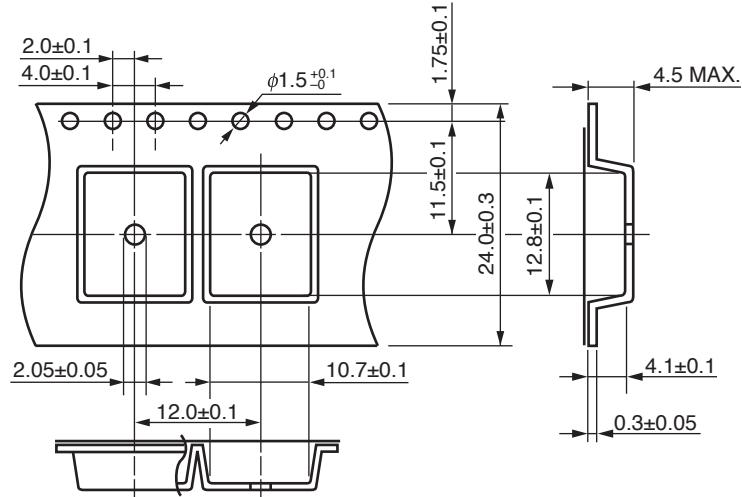

Tape Direction

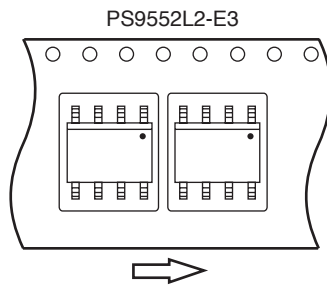

Outline and Dimensions (Reel)

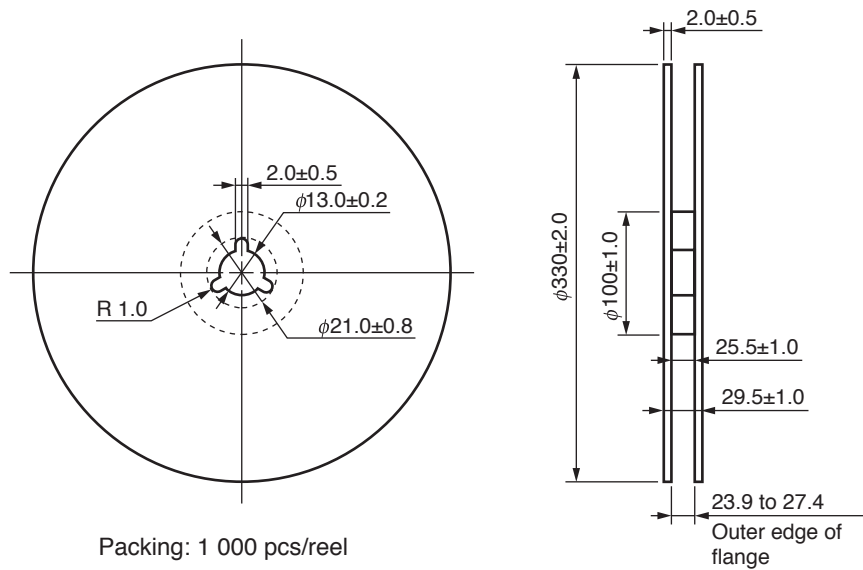

Outline and Dimensions (Tape)

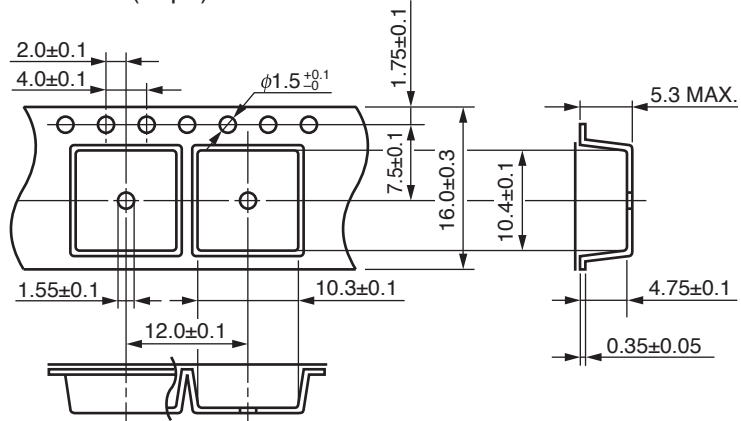

Tape Direction

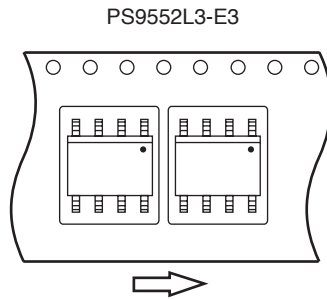

Outline and Dimensions (Reel)

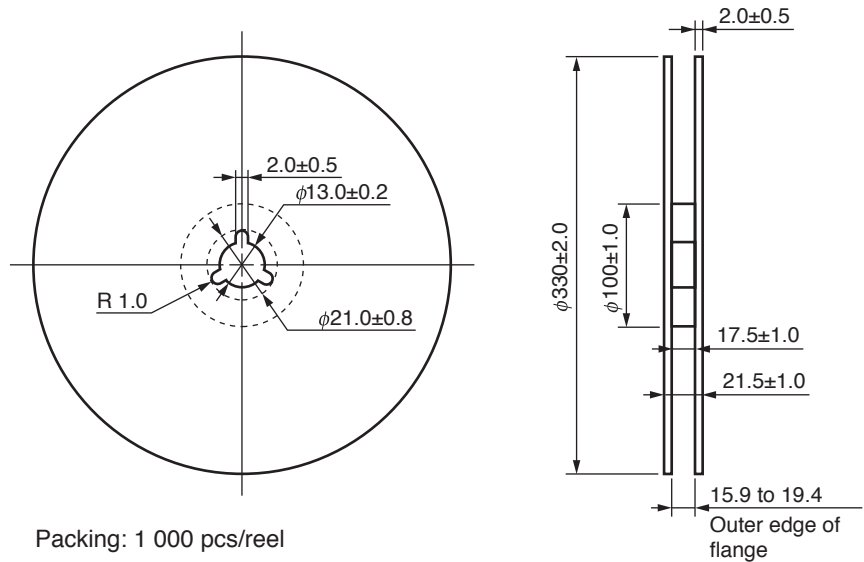



<R> RECOMMENDED MOUNT PAD DIMENSIONS (UNIT: mm)

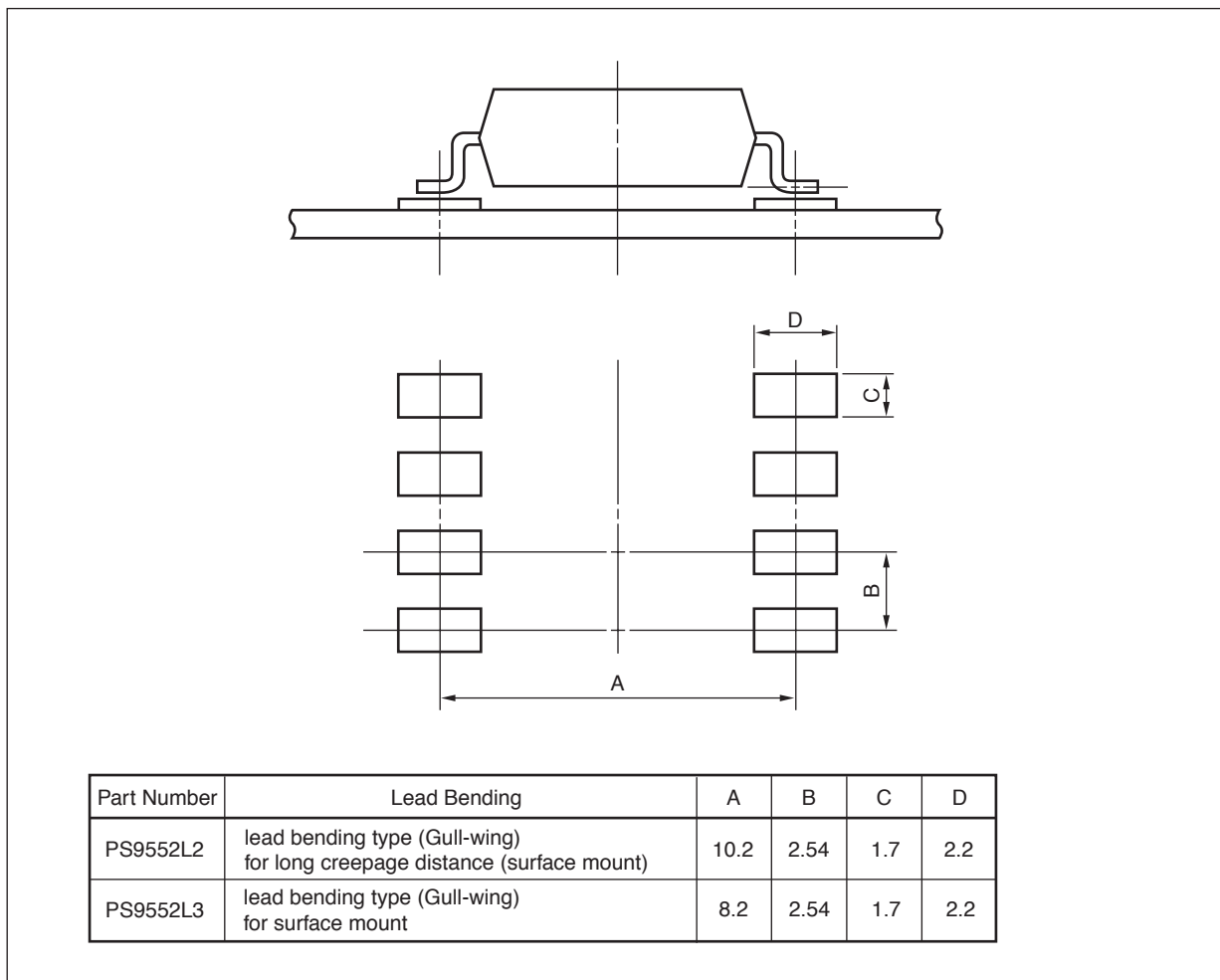

**NOTES ON HANDLING**

**1. Recommended soldering conditions**

**(1) Infrared reflow soldering**

- Peak reflow temperature 260°C or below (package surface temperature)
- Time of peak reflow temperature 10 seconds or less
- Time of temperature higher than 220°C 60 seconds or less
- Time to preheat temperature from 120 to 180°C 120±30 s
- Number of reflows Three
- Flux Rosin flux containing small amount of chlorine (The flux with a maximum chlorine content of 0.2 Wt% is recommended.)

Recommended Temperature Profile of Infrared Reflow

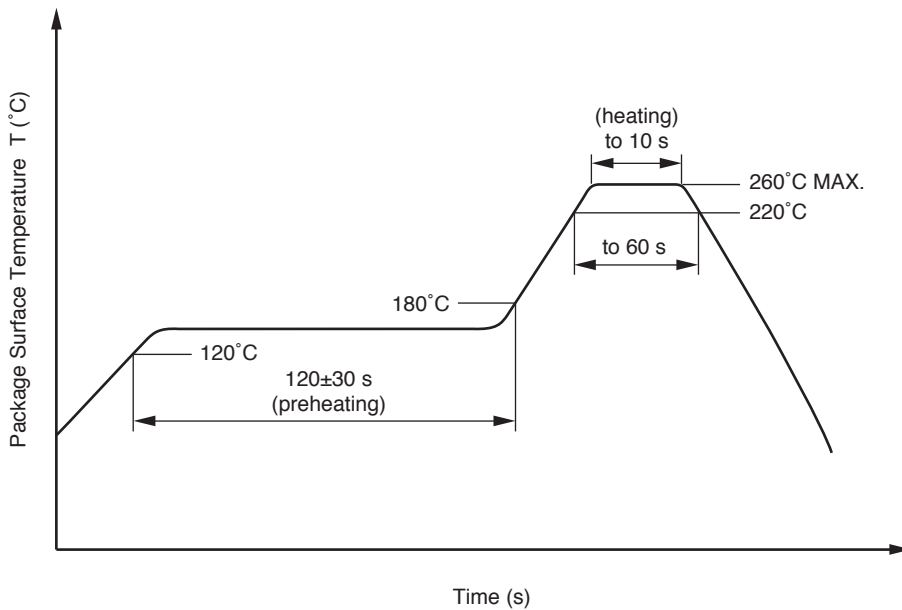

**(2) Wave soldering**

- Temperature 260°C or below (molten solder temperature)
- Time 10 seconds or less
- Preheating conditions 120°C or below (package surface temperature)
- Number of times One (Allowed to be dipped in solder including plastic mold portion.)
- Flux Rosin flux containing small amount of chlorine (The flux with a maximum chlorine content of 0.2 Wt% is recommended.)

**(3) Soldering by Soldering Iron**

- Peak Temperature (lead part temperature) 350°C or below
- Time (each pins) 3 seconds or less
- Flux Rosin flux containing small amount of chlorine (The flux with a maximum chlorine content of 0.2 Wt% is recommended.)

- (a) Soldering of leads should be made at the point 1.5 to 2.0 mm from the root of the lead
- (b) Please be sure that the temperature of the package would not be heated over 100°C

**(4) Cautions**

## • Fluxes

Avoid removing the residual flux with freon-based and chlorine-based cleaning solvent.

<R> **2. Cautions regarding noise**

Be aware that when voltage is applied suddenly between the photocoupler's input and output at startup, the output transistor may enter the on state, even if the voltage is within the absolute maximum ratings.

**USAGE CAUTIONS**

1. This product is weak for static electricity by designed with high-speed integrated circuit so protect against static electricity when handling.

<R> **2. Board designing**

(1) By-pass capacitor of more than 0.1  $\mu\text{F}$  is used between  $V_{CC}$  and GND near device. Also, ensure that the distance between the leads of the photocoupler and capacitor is no more than 10 mm.

(2) In order to avoid malfunctions and characteristics degradation, IGBT collector or emitter traces should not be closed to the LED input.

<R> **3.** Make sure the rise/fall time of the forward current is 0.5  $\mu\text{s}$  or less.

<R> **4.** In order to avoid malfunctions, make sure the rise/fall slope of the supply voltage is 3 V/ $\mu\text{s}$  or less.

**5.** Avoid storage at a high temperature and high humidity.

<R> SPECIFICATION OF VDE MARKS LICENSE DOCUMENT

Parameter	Symbol	Speck	Unit
Application classification (DIN EN 60664-1 VDE0110 Part 1) for rated line voltages ≤ 300 Vr.m.s. for rated line voltages ≤ 600 Vr.m.s.		IV III	
Climatic test class (DIN EN 60664-1 VDE0110)		55/100/21	
Dielectric strength maximum operating isolation voltage Test voltage (partial discharge test, procedure a for type test and random test) $U_{pr} = 1.5 \times U_{IORM}, P_d < 5 \text{ pC}$	$U_{IORM}$ $U_{pr}$	1 130 1 695	$V_{peak}$ $V_{peak}$
Test voltage (partial discharge test, procedure b for all devices) $U_{pr} = 1.875 \times U_{IORM}, P_d < 5 \text{ pC}$	$U_{pr}$	2 119	$V_{peak}$
Highest permissible overvoltage	$U_{TR}$	8 000	$V_{peak}$
Degree of pollution (DIN EN 60664-1 VDE0110 Part 1)		2	
Clearance distance	PS9552, PS9552L3	>7.0	mm
	PS9552L1, PS9552L2	>8.0	
Creepage distance	PS9552, PS9552L3	>7.0	mm
	PS9552L1, PS9552L2	>8.0	
Comparative tracking index (DIN IEC 112/VDE 0303 Part 1)	CTI	175	
Material group (DIN EN 60664-1 VDE0110 Part 1)		III a	
Storage temperature range	$T_{stg}$	-55 to +125	°C
Operating temperature range	$T_A$	-40 to +85	°C
Isolation resistance, minimum value $V_{IO} = 500 \text{ V dc at } T_A = 25^\circ\text{C}$ $V_{IO} = 500 \text{ V dc at } T_A \text{ MAX. at least } 100^\circ\text{C}$	Ris MIN.	$10^{12}$	$\Omega$
	Ris MIN.	$10^{11}$	$\Omega$
Safety maximum ratings (maximum permissible in case of fault, see thermal derating curve)			
Package temperature	$T_{si}$	175	°C
Current (input current $I_F$ , $\Psi_i = 0$ )	$I_{si}$	400	mA
Power (output or total power dissipation)	$\Psi_{si}$	700	mW
Isolation resistance $V_{IO} = 500 \text{ V dc at } T_A = T_{si}$	Ris MIN.	$10^9$	$\Omega$

- **The information in this document is current as of October, 2007. The information is subject to change without notice. For actual design-in, refer to the latest publications of NEC Electronics data sheets or data books, etc., for the most up-to-date specifications of NEC Electronics products. Not all products and/or types are available in every country. Please check with an NEC Electronics sales representative for availability and additional information.**
- No part of this document may be copied or reproduced in any form or by any means without the prior written consent of NEC Electronics. NEC Electronics assumes no responsibility for any errors that may appear in this document.
- NEC Electronics does not assume any liability for infringement of patents, copyrights or other intellectual property rights of third parties by or arising from the use of NEC Electronics products listed in this document or any other liability arising from the use of such products. No license, express, implied or otherwise, is granted under any patents, copyrights or other intellectual property rights of NEC Electronics or others.
- Descriptions of circuits, software and other related information in this document are provided for illustrative purposes in semiconductor product operation and application examples. The incorporation of these circuits, software and information in the design of a customer's equipment shall be done under the full responsibility of the customer. NEC Electronics assumes no responsibility for any losses incurred by customers or third parties arising from the use of these circuits, software and information.
- While NEC Electronics endeavors to enhance the quality, reliability and safety of NEC Electronics products, customers agree and acknowledge that the possibility of defects thereof cannot be eliminated entirely. To minimize risks of damage to property or injury (including death) to persons arising from defects in NEC Electronics products, customers must incorporate sufficient safety measures in their design, such as redundancy, fire-containment and anti-failure features.
- NEC Electronics products are classified into the following three quality grades: "Standard", "Special" and "Specific".

The "Specific" quality grade applies only to NEC Electronics products developed based on a customer-designated "quality assurance program" for a specific application. The recommended applications of an NEC Electronics product depend on its quality grade, as indicated below. Customers must check the quality grade of each NEC Electronics product before using it in a particular application.

"Standard": Computers, office equipment, communications equipment, test and measurement equipment, audio and visual equipment, home electronic appliances, machine tools, personal electronic equipment and industrial robots.

"Special": Transportation equipment (automobiles, trains, ships, etc.), traffic control systems, anti-disaster systems, anti-crime systems, safety equipment and medical equipment (not specifically designed for life support).

"Specific": Aircraft, aerospace equipment, submersible repeaters, nuclear reactor control systems, life support systems and medical equipment for life support, etc.

The quality grade of NEC Electronics products is "Standard" unless otherwise expressly specified in NEC Electronics data sheets or data books, etc. If customers wish to use NEC Electronics products in applications not intended by NEC Electronics, they must contact an NEC Electronics sales representative in advance to determine NEC Electronics' willingness to support a given application.

(Note)

- (1) "NEC Electronics" as used in this statement means NEC Electronics Corporation and also includes its majority-owned subsidiaries.
- (2) "NEC Electronics products" means any product developed or manufactured by or for NEC Electronics (as defined above).

M8E 02.11-1

<b>Caution</b> GaAs Products	<p>This product uses gallium arsenide (GaAs). GaAs vapor and powder are hazardous to human health if inhaled or ingested, so please observe the following points.</p> <ul style="list-style-type: none"><li>• Follow related laws and ordinances when disposing of the product. If there are no applicable laws and/or ordinances, dispose of the product as recommended below.<ol style="list-style-type: none"><li>1. Commission a disposal company able to (with a license to) collect, transport and dispose of materials that contain arsenic and other such industrial waste materials.</li><li>2. Exclude the product from general industrial waste and household garbage, and ensure that the product is controlled (as industrial waste subject to special control) up until final disposal.</li></ol></li><li>• Do not burn, destroy, cut, crush, or chemically dissolve the product.</li><li>• Do not lick the product or in any way allow it to enter the mouth.</li></ul>
------------------------------	--

Subject: Compliance with EU Directives

CEL certifies, to its knowledge, that semiconductor and laser products detailed below are compliant with the requirements of European Union (EU) Directive 2002/95/EC Restriction on Use of Hazardous Substances in electrical and electronic equipment (RoHS) and the requirements of EU Directive 2003/11/EC Restriction on Penta and Octa BDE.

CEL Pb-free products have the same base part number with a suffix added. The suffix –A indicates that the device is Pb-free. The –AZ suffix is used to designate devices containing Pb which are exempted from the requirement of RoHS directive (\*). In all cases the devices have Pb-free terminals. All devices with these suffixes meet the requirements of the RoHS directive.

This status is based on CEL’s understanding of the EU Directives and knowledge of the materials that go into its products as of the date of disclosure of this information.

Restricted Substance per RoHS	Concentration Limit per RoHS (values are not yet fixed)	Concentration contained in CEL devices	
		-A	-AZ
Lead (Pb)	< 1000 PPM	Not Detected	(*)
Mercury	< 1000 PPM	Not Detected	
Cadmium	< 100 PPM	Not Detected	
Hexavalent Chromium	< 1000 PPM	Not Detected	
PBB	< 1000 PPM	Not Detected	
PBDE	< 1000 PPM	Not Detected	

If you should have any additional questions regarding our devices and compliance to environmental standards, please do not hesitate to contact your local representative.

**Important Information and Disclaimer:** Information provided by CEL on its website or in other communications concerning the substance content of its products represents knowledge and belief as of the date that it is provided. CEL bases its knowledge and belief on information provided by third parties and makes no representation or warranty as to the accuracy of such information. Efforts are underway to better integrate information from third parties. CEL has taken and continues to take reasonable steps to provide representative and accurate information but may not have conducted destructive testing or chemical analysis on incoming materials and chemicals. CEL and CEL suppliers consider certain information to be proprietary, and thus CAS numbers and other limited information may not be available for release.

In no event shall CEL’s liability arising out of such information exceed the total purchase price of the CEL part(s) at issue sold by CEL to customer on an annual basis.

See CEL Terms and Conditions for additional clarification of warranties and liability.