

# NEC Optocouplers

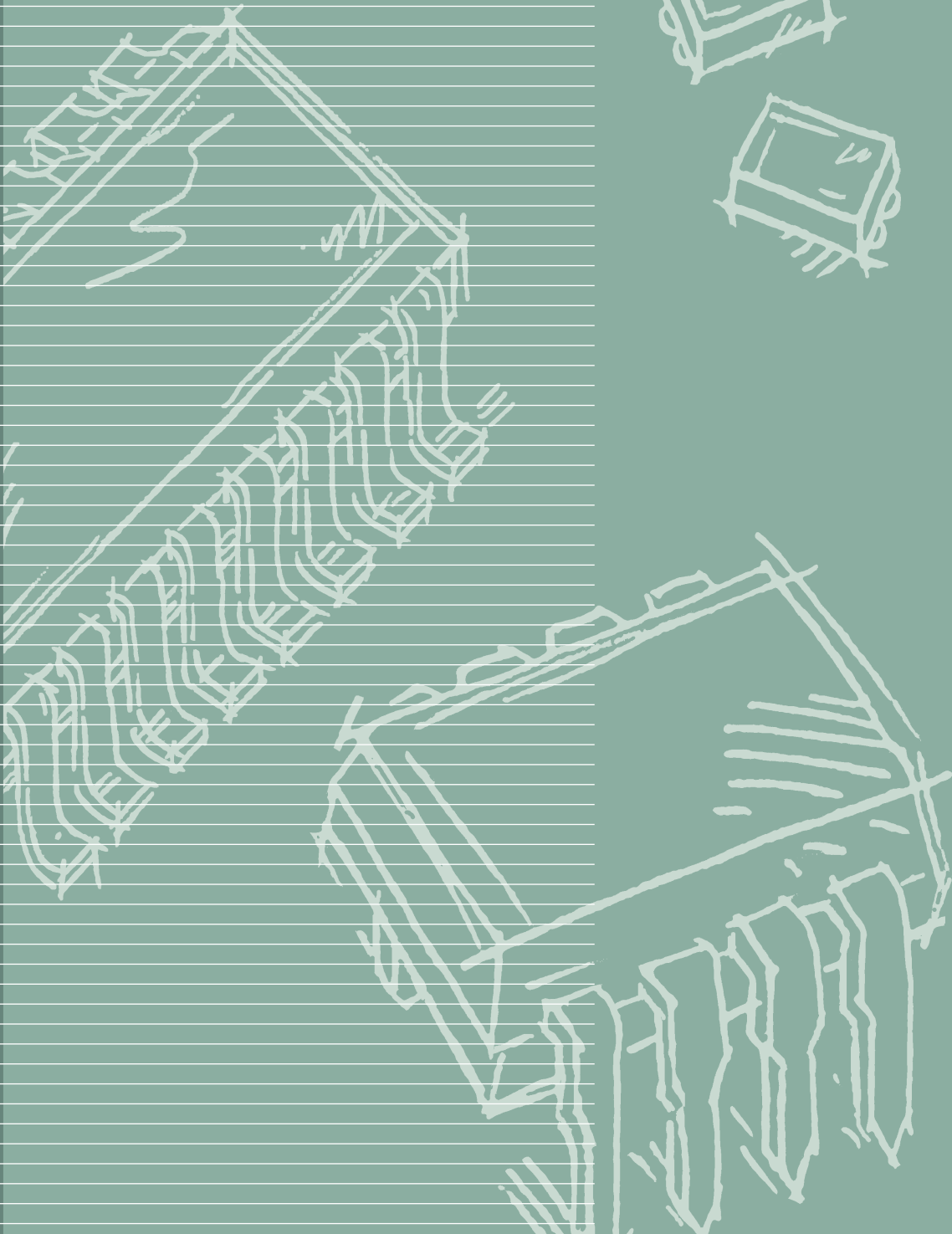

2006

# NEC&CEL

**California Eastern Laboratories** is the exclusive sales and marketing partner for products made by the Compound Semiconductor Devices Division (CSDD) of NEC Electronics Corporation. These include Optocouplers, Solid State Relays, RF and wireless ICs and transistors, and fiber optic lasers and detectors. Serving customers throughout North and South America, CEL maintains extensive inventories, sets pricing, and provides engineering and applications support. CEL has sales offices throughout the hemisphere, plus a network of reps and distributors.

## CONTENTS

<b>NEC Optocoupler Family Overview and Part Numbering System</b>	<b>2</b>
<b>High Speed Digital</b>	<b>3</b>
<b>High Speed Digital, CMOS</b>	<b>4</b>
<b>High Speed Analog</b>	<b>4</b>
<b>Single Transistor, General Purpose, DC</b>	<b>5</b>
<b>Single Transistor, General Purpose, AC</b>	<b>6</b>
<b>Single Transistor, General Purpose</b>	
DC, optimized for power supplies	<b>7</b>
AC, optimized for power supplies	<b>7</b>
<b>Single Transistor, 0.4mm insulation (BSI)</b>	
DC, high isolation voltage	<b>8</b>
AC devices	<b>8</b>
<b>Single Transistor, High Drive Current</b>	
DC, high isolation voltage	<b>9</b>
AC, high isolation voltage	<b>9</b>
<b>Single Transistor, High Speed, High Vce</b>	
DC devices	<b>9</b>
AC devices	<b>9</b>
<b>Single Transistor in Mini-Quad Packages</b>	<b>10</b>
<b>High Linearity, Analog Signal</b>	<b>10</b>
<b>Darlington Transistor, General Purpose</b>	
DC, high isolation voltage	<b>11</b>
AC, high isolation voltage	<b>11</b>
<b>Darlington Transistor, 0.4mm insulation (BSI)</b>	
DC, high isolation voltage	<b>12</b>
AC, high isolation voltage	<b>12</b>
<b>Darlington Transistor, High V<sub>CE0</sub>, DC</b>	<b>12</b>
<b>NEC Optocoupler Packages</b>	<b>13 – 16</b>

## SUPPORT

**Product Selection Guides**  
**Data Sheets**  
**Product & Application Notes**  
**Reference Designs**  
**Cross References**









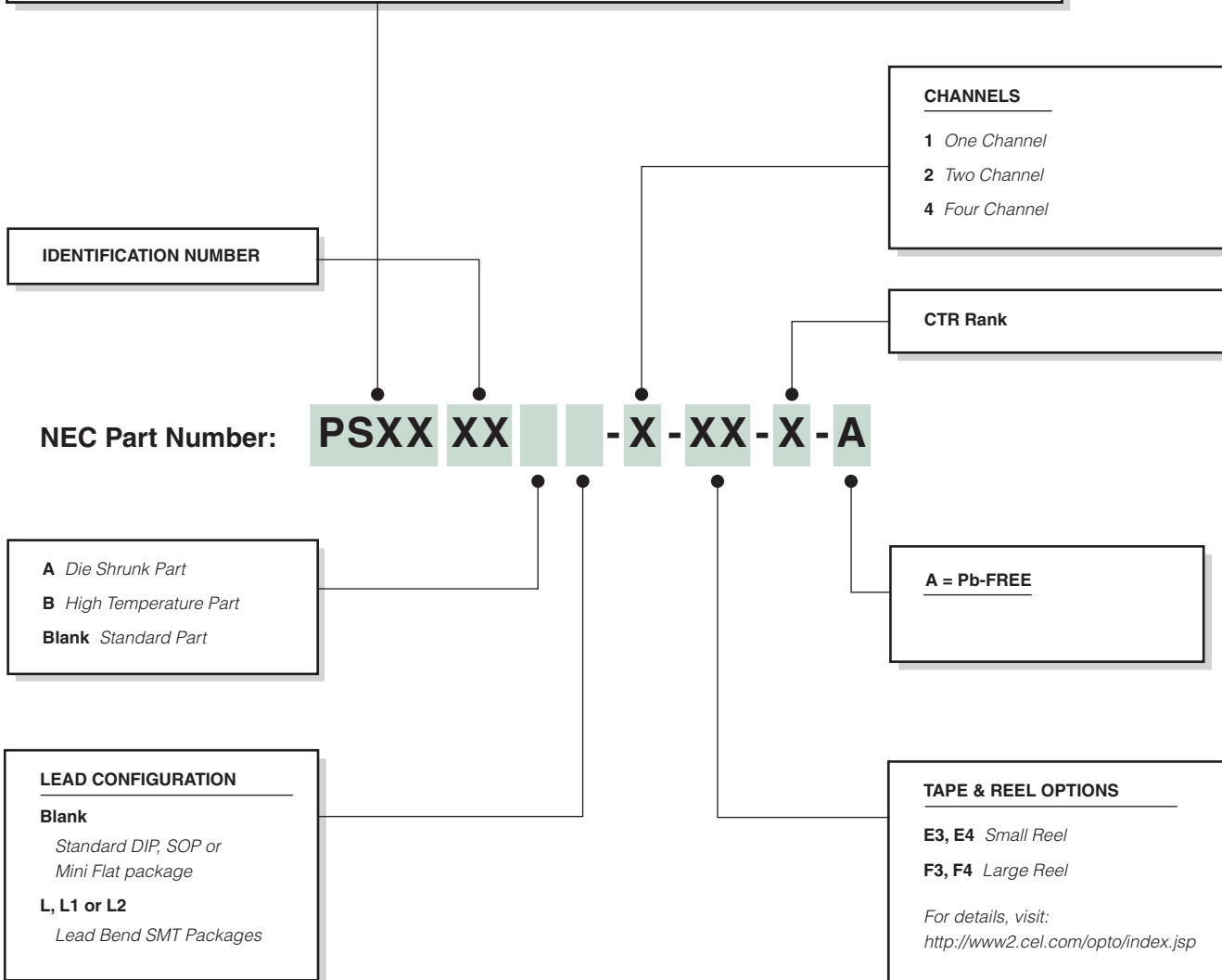





For information visit [www.cel.com](http://www.cel.com)

# NEC Optocoupler Families

## Overview, Package Styles and Part Numbering System

Part Number	Description	Package Styles Available	Pkg Drawing (Page No.)
<b>PS25XX Series</b>	Transistor Output	4, 8, and 16 Pin DIP and SMT	<b>13-15</b>
<b>PS27XX Series</b>	Transistor Output	4 Pin SOP (2.54mm pin pitch)	<b>15</b>
<b>PS28XX Series</b>	Transistor Output	4, 12 and 16 pin SSOP (1.27mm pin pitch)	<b>15-16</b>
<b>PS29XX Series</b>	Transistor Output	4 pin Mini Flat (flat lead, 1.27mm pin pitch)	<b>16</b>
<b>PS81XX Series</b>	High Speed Analog	5 pin SOP (1.27mm pin pitch)	<b>16</b>
<b>PS86XX Series</b>	High Speed Analog	8 pin DIP and SMT	<b>14</b>
<b>PS87XX</b>	High Linearity Analog	16 pin SSOP (1.27mm pin pitch)	<b>16</b>
<b>PS88XX Series</b>	High Speed Analog	S08	<b>16</b>
<b>PS91XX Series</b>	High Speed Digital	5 pin SOP (1.27mm pin pitch)	<b>16</b>
<b>PS92XX Series</b>	High Speed Digital	5 pin SOP (5.5mm Creepage)	<b>16</b>
<b>PS96XX Series</b>	High Speed Digital	8 pin DIP and SMT	<b>14</b>
<b>PS9661</b>	CMOS High Speed Digital	8 pin DIP and SMT	<b>14</b>
<b>PS98XX Series</b>	High Speed Digital	S08	<b>16</b>



Part Number	Pin Connections	Digital Speed (Mbps)	Vcc Range (V)	Typ I <sub>FHL</sub> (mA)	Typ		BV (V <sub>r.m.s.</sub> )	Safety Certification	Package Style
					t <sub>PHL</sub> (ns)	t <sub>PLH</sub> (ns)			
PS9113 <sup>1</sup>		1	4.5 to 30	1.5	250	520	2500	UL, VDE	5 Pin SOP
PS9115 <sup>2</sup>		10	4.5 to 5.5	2.3	33	40	2500	UL, VDE	5 Pin SOP
PS9117 <sup>1</sup>		10	4.5 to 5.5	2	35	40	2500	UL, VDE	5 Pin SOP
PS9121 <sup>1</sup>		10	2.7 to 5.5	2.5	40	45	2500	UL, VDE	5 Pin SOP
<b>PS9213<sup>1</sup></b> <i>5.5mm Creepage</i>		1	4.5 to 30	1.5	250	520	2500	UL, VDE	5 Pin SOP
<b>PS9214<sup>1</sup></b> <i>5.5mm Creepage</i>		10	4.5 to 5.5	2	54	51	2500	UL, VDE	5 Pin SOP
PS9613 <sup>1</sup>		1	4.5 to 30	1.5	250	520	5000	UL, VDE	8 Pin DIP or L SMT
PS9617 <sup>1</sup>		10	4.5 to 5.5	2.5	40	43	5000	UL, VDE	8 Pin DIP or L SMT
<b>PS9687<sup>1</sup></b> <i>8mm Creepage</i>		10	4.5 to 5.5	2.5	40	55	5000	UL, VDE	8 Pin L1 or L2 SMT
PS9817-1 <sup>1</sup>		10	4.5 to 5.5	2.0	40	45	2500	UL, VDE	S08
PS9817-2 <sup>1</sup>		10	4.5 to 5.5	2.0	40	45	2500	UL, VDE	S08
PS9821-1 <sup>1</sup>		10	2.7 to 5.5	2.5	45	50	2500	UL, VDE	S08
PS9821-2 <sup>1</sup>		10	2.7 to 5.5	2.5	45	50	2500	UL, VDE	S08
<b>PS9851-1<sup>3</sup></b> <i>-40 to 100°C</i>		15	4.5 to 5.5	2.8	34	37	2500	UL, VDE	S08
<b>PS9851-2<sup>3</sup></b> <i>-40 to 100°C</i>		15	4.5 to 5.5	2.8	34	37	2500	UL, VDE	S08

NOTES: 1. Open collector output. 2. Totem pole output. 3. CMOS output.

## CMOS High Speed Digital Optocouplers









10kV/ $\mu$ s Minimum Noise Immunity

Part Number	Pin Connections	Digital Speed (Mbps)	V <sub>cc</sub> Range (V)	V <sub>IH</sub> min (V)	V <sub>IL</sub> max (V)	Typ		BV (V <sub>r.m.s.</sub> )	Safety Certification	Package Style
						t <sub>PHL</sub> (ns)	t <sub>PLH</sub> (ns)			
PS9661		25	4.5 to 5.5	2.0	0.8	20	23	3750	UL, VDE	8 Pin DIP or L SMT

## High Speed Analog Optocouplers

High Noise Immunity

CTR measured @ V<sub>CE</sub> = 4.5V, I<sub>F</sub> = 16mA







Part Number	Pin Connections	Speed (Mbps)	Absolute Maximum Ratings			t <sub>PHL</sub> ( $\mu$ s)	t <sub>PLH</sub> ( $\mu$ s)	CTR (%) (Full Range) Rank	Safety Certification	Package Style
			BV (V <sub>r.m.s.</sub> )	V <sub>cc</sub> (V)	I <sub>c</sub> (mA)					
PS8101		1	2500	35	8	.5	.6	(N = 15 to 35) K = 20 to 35	UL, VDE	5 Pin SSOP
PS8103		0.2	2500	15	8	1	2	(N = 10 to 30)	UL	5 Pin SSOP
PS8601		1	5000	35	8	.5	.3	(15 min.)	UL, VDE, BSI	5 Pin SSOP
PS8602		1	5000	35	8	.5	.3	(15 min.)	UL, VDE, BSI	8 Pin DIP or L, L1, L2 SMT
PS8802-1		1	2500	35	8	.3	.6	(N = 15 to 35)	UL, VDE	S08
PS8802-2		1	2500	35	8	.3	.6	(N = 15 to 35)	UL, VDE	S08
PS8821-1 <sup>1</sup>		1	2500	7	8	.3	.5	(N = 20 to 40)	UL, VDE	S08
PS8821-2 <sup>1</sup>		1	2500	7	8	.3	.5	(N = 20 to 40)	UL, VDE	S08

NOTES: 1. CTR measured at V<sub>cc</sub> = 3.3V, I<sub>F</sub> = 16mA

# Single Transistor, General Purpose DC Optocouplers

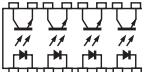
Ideal for low speed logic applications



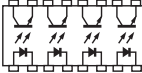
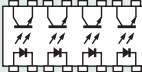



CTR measured @  $V_{CE} = 5V$ ,  $I_F = 5mA$

Part Number	Pin Connections	Absolute Maximum Ratings				CTR (%) (N = Full Range) Rank	Safety Certification	Package Style
		BV (V <sub>r.m.s.</sub> )	V <sub>CEO</sub> (V)	I <sub>F</sub> (mA)	I <sub>C</sub> (mA)			
PS2501-1		5000	80	80	50	<b>(N = 80 to 600)</b> K = 300 to 600 L = 200 to 400 M = 80 to 240 D = 100 to 300 H = 80 to 160 W = 130 to 260 Q = 100 to 200	UL	4 Pin DIP or L SMT
<b>PS2501A-1</b> <i>High Noise Immunity</i>		5000	70	30	30	<b>(N = 50 to 400)</b> H = 80 to 160 W = 130 to 260 Q = 100 to 200 L = 200 to 400	UL	4 Pin DIP or L SMT
PS2501-2		5000	80	80	50	<b>(N = 80 to 600)</b>	UL	8 Pin DIP or L SMT
PS2501-4		5000	80	80	50	<b>(N = 80 to 600)</b>	UL	16 Pin DIP or L SMT
PS2701-1		3750	40	50	80	<b>(N = 50 to 300)</b> P = 150 to 300 L = 100 to 300 M = 50 to 150	UL, VDE, BSI	4 Pin SOP
<b>PS2701A-1</b> <i>High Noise Immunity</i>		3750	70	30	30	<b>(N = 50 to 300)</b> P = 150 to 300 L = 100 to 300 M = 50 to 150	UL, VDE	4 Pin SOP
PS2801-1		2500	80	50	50	<b>(N = 80 to 600)</b> K = 300 to 600 L = 100 to 300 P = 150 to 300	UL, VDE, BSI	4 Pin SSOP
<b>PS2801A-1</b> <i>High Noise Immunity</i>		2500	70	30	30	<b>(N = 50 to 300)</b> L = 100 to 300 P = 150 to 300	UL, VDE	4 Pin SSOP
PS2801-4		2500	80	50	50	<b>(N = 80 to 600)</b>	UL, VDE, BSI	16 Pin SSOP
<b>PS2801A-4</b> <i>High Noise Immunity</i>		2500	70	30	30	<b>(N = 80 to 600)</b>	UL, VDE	16 Pin SSOP

# Single Transistor, General Purpose AC Optocouplers

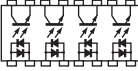
High isolation voltage



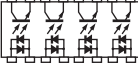
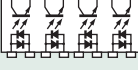

CTR measured @  $V_{CE} = 5V$ ,  $I_F = \pm 5mA$

Part Number	Pin Connections	Absolute Maximum Ratings				CTR (%) (N = Full Range) Rank	Safety Certification	Package Style
		BV (V <sub>r.m.s.</sub> )	V <sub>CEO</sub> (V)	I <sub>F</sub> (mA)	I <sub>c</sub> (mA)			
PS2505-1		5000	80	±80	50	<b>(N = 80 to 600)</b>	UL	4 Pin DIP or L SMT
PS2505-2		5000	80	±80	50	<b>(N = 80 to 600)</b>	UL	8 Pin DIP or L SMT
PS2505-4		5000	80	±80	50	<b>(N = 80 to 600)</b>	UL	16 Pin DIP or L SMT
PS2705-1		3750	40	±50	80	<b>(N = 50 to 300)</b> P = 150 to 300 L = 100 to 300 M = 50 to 150	UL, VDE, BSI	4 Pin SOP
<b>PS2705A-1</b> <i>High Noise Immunity</i>		3750	70	±30	30	<b>(N = 50 to 300)</b> L = 100 to 300 M = 50 to 150	UL, VDE	4 Pin SOP
PS2805-1		2500	80	±50	50	<b>(N = 80 to 600)</b>	UL, VDE, BSI	4 Pin SSOP
<b>PS2805A-1</b> <i>High Noise Immunity</i>		2500	70	±30	30	<b>(N = 50 to 400)</b>	UL, VDE	4 Pin SSOP
PS2805-4		2500	80	±50	50	<b>(N = 80 to 600)</b>	UL, VDE, BSI	16 Pin SSOP
<b>PS2805A-4</b> <i>High Noise Immunity</i>		2500	70	±30	30	<b>(N = 50 to 400)</b>	UL, VDE	16 Pin SSOP

# Single Transistor, General Purpose Optocouplers



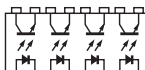

DC Devices Optimized for Power Supply Applications

CTR measured @  $V_{CE} = 5V$ ,  $I_F = 1mA$

Part Number	Pin Connections	Absolute Maximum Ratings				CTR (%) (N = Full Range) Rank	Safety Certification	Package Style
		BV (V.r.m.s.)	$V_{CE0}$ (V)	$I_F$ (mA)	$I_C$ (mA)			
PS2711-1		3750	40	50	40	<b>(N = 100 to 400)</b> K = 200 to 400 L = 150 to 300 M = 100 to 200	UL, VDE	4 Pin SOP
PS2811-1		2500	40	50	40	<b>(N = 100 to 400)</b> K = 200 to 400 L = 150 to 300 M = 100 to 200	UL, VDE	4 Pin SSOP
PS2811-4		2500	40	50	40	<b>(N = 100 to 400)</b>	UL, VDE	16 Pin SSOP
PS2911-1		2500	40	50	40	<b>(N = 100 to 400)</b> K = 200 to 400 L = 150 to 300 M = 100 to 200	UL, VDE, BSI	4 Pin Mini Flat

AC Devices Optimized for Power Supply Applications

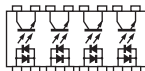
CTR measured @  $V_{CE} = 5V$ ,  $I_F = 1mA$









PS2715-1		3750	40	$\pm 50$	40	<b>(N = 100 to 400)</b>	UL, VDE	4 Pin SOP
PS2815-1		2500	40	$\pm 50$	40	<b>(N = 100 to 400)</b>	UL, VDE	4 Pin SSOP
PS2815-4		2500	40	$\pm 50$	40	<b>(N = 100 to 400)</b>	UL, VDE	4 Pin SSOP
PS2915-1		2500	40	$\pm 50$	30	<b>(N = 100 to 400)</b>	UL, VDE, BSI	4 Pin Mini Flat



# Single Transistor Optocouplers, Guaranteed 0.4mm Insulation (BSI)



DC Devices, High Isolation Voltage

CTR measured @  $V_{CE} = 5V$ ,  $I_F = 5mA$

Part Number	Pin Connections	Absolute Maximum Ratings				CTR (%) (N = Full Range) Rank	Safety Certification	Package Style
		BV (V <sub>r.m.s.</sub> )	V <sub>CEO</sub> (V)	I <sub>F</sub> (mA)	I <sub>C</sub> (mA)			
PS2561-1		5000	80	80	50	<b>(N = 80 to 400)</b> L = 200 to 400 M = 80 to 240 D = 100 to 300 H = 80 to 160 W = 130 to 260	UL, VDE, BSI	4 Pin DIP or 4 Pin L, L1 SMT
<b>PS2561A-1</b> <i>High Noise Immunity</i>		5000	70	30	30	<b>(N = 50 to 300)</b> H = 80 to 160 Q = 100 to 200 W = 130 to 260	UL, VDE, BSI	4 Pin DIP or L, L1, L2 Lead Bend
<b>PS2561B-1</b> <i>110°C Part</i>		5000	80	40	50	<b>(N = 100 to 400)</b>	UL, VDE	4 Pin DIP or L, L1, L2 SMT
<b>PS2581-1</b> <i>8mm Creepage</i>		5000	80	80	50	<b>(N = 80 to 400)</b>	UL, VDE, BSI	4 Pin L1 or L2 SMT
<b>PS2581A-1</b> <i>8mm Creepage</i>		5000	70	30	30	<b>(N = 50 to 300)</b>	UL, VDE, BSI	4 Pin L1 or L2 SMT
PS2761-1		3750	40	50	40	<b>(N = 50 to 400)</b> K = 200 to 400 M = 50 to 150 L = 100 to 300	UL, VDE, BSI	4 Pin SOP
PS2861-1		2500	40	50	40	<b>(N = 50 to 400)</b> K = 200 to 400 M = 50 to 150 L = 100 to 300	UL, VDE, BSI	4 Pin SSOP
PS2861H-1		3000	40	50	40	<b>(N = 50 to 400)</b> K = 200 to 400 L = 100 to 300 M = 50 to 150	UL, VDE,	4 Pin SSOP

## AC Devices

CTR measured @  $V_{CE} = 5V$ ,  $I_F = 5mA$

PS2565-1		5000	80	±80	50	<b>(N = 80 to 400)</b>	UL, VDE, BSI	4 Pin DIP or L, L1, L2 SMT
PS2765-1		3750	40	±50	40	<b>(N = 50 to 400)</b>	UL, VDE, BSI	4 Pin SOP
PS2865-1		2500	40	±50	40	<b>(N = 50 to 400)</b>	UL, VDE, BSI	4 Pin SSOP

## Single Transistor, High Drive Current Optocouplers

DC Devices, High Isolation Voltage

CTR measured @  $V_{CE} = 3V$ ,  $I_F = 100mA$

Part Number	Pin Connections	Absolute Maximum Ratings				CTR (%) N = Full Range Rank	Safety Certification	Package Style
		BV (V <sub>r.m.s.</sub> )	V <sub>CEO</sub> (V)	I <sub>F</sub> (mA)	I <sub>C</sub> (mA)			
PS2521-1		5000	80	150	50	<b>N = 20 to 80</b>	UL	4 Pin DIP or L SMT

AC Devices, High Isolation Voltage







CTR measured @  $V_{CE} = 3V$ ,  $I_F = 100mA$

PS2525-1		5000	80	±150	50	<b>N = 20 to 80</b>	UL	4 Pin DIP or L SMT
----------	---	------	----	------	----	---------------------	----	-----------------------

## Single Transistor, High Speed and High V<sub>CE</sub> Optocouplers

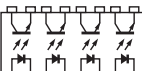
DC Devices

CTR measured @  $V_{CE}$  and  $I_F$  as noted

Part Number	Pin Connections	Absolute Maximum Ratings				CTR (%) N = Full Range Rank	Safety Certification	Package Style
		BV (V <sub>r.m.s.</sub> )	V <sub>CEO</sub> (V)	I <sub>F</sub> (mA)	I <sub>C</sub> (mA)			
PS2503-1		5000	40	80	30	<b><math>V_{CE} = 5V</math>, <math>I_F = 1mA</math></b> <b>(N = 100 to 400)</b> K = 200 to 400 L = 150 to 300 M = 100 to 200	UL	4 Pin DIP or L SMT
PS2503-2		5000	40	80	30	<b><math>V_{CE} = 5V</math>, <math>I_F = 1mA</math></b> <b>(N = 100 to 400)</b>	UL	8 Pin DIP or L SMT
PS2503-4		5000	40	80	30	<b><math>V_{CE} = 5V</math>, <math>I_F = 1mA</math></b> <b>(N = 100 to 400)</b>	UL	16 Pin DIP or L SMT
PS2513-1		5000	120	60	30	<b><math>V_{CE} = 5V</math>, <math>I_F = 5mA</math></b> <b>(N = 50 to 200)</b> <b><math>V_{CE} = 5V</math>, <math>I_F = 1mA</math></b> <b>(N = 25 to 100)</b>	UL	4 Pin DIP or L SMT
PS2703-1		3750	120	50	30	<b><math>V_{CE} = 5V</math>, <math>I_F = 5mA</math></b> <b>(N = 50 to 400)</b> K = 200 to 400 L = 100 to 300 M = 50 to 150	UL, VDE, BSI	4 Pin SOP
PS2913-1		2500	120	50	30	<b><math>V_{CE} = 5V</math>, <math>I_F = 1mA</math></b> <b>(N = 50 to 200)</b>	UL, VDE, BSI	4 Pin Mini Flat

AC Device

CTR measured @  $V_{CE}$  and  $I_F$  as noted

PS2707-1		3750	120	50	30	<b><math>V_{CE} = 5V</math>, <math>I_F = 5mA</math></b> <b>(N = 50 to 400)</b>	UL, VDE, BSI	4 Pin SOP
----------	---	------	-----	----	----	---	-----------------	-----------

## Single Transistor Optocouplers in Miniature Quad Packages

DC Devices

CTR measured @  $V_{CE} = 5V$ ,  $I_F = 50\text{ mA}$

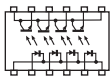
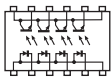
Part Number	Pin Connections	Absolute Maximum Ratings				CTR (%) (N = Full Range) Rank	Safety Certification	Package Style
		BV (V <sub>r.m.s.</sub> )	V <sub>CEO</sub> (V)	I <sub>F</sub> (mA)	I <sub>C</sub> (mA)			
PS2841-4A		1500	70	20	20	(N = 100 to 400)	UL	12 Pin SSOP
PS2841-4B		1500	70	20	20	(N = 100 to 400)	UL	12 Pin SSOP

AC Devices, CTR measured @  $V_{CE} = 5V$ ,  $I_F = \pm 50\text{ mA}$

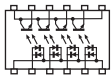
PS2845-4A		1500	70	$\pm 20$	20	(N = 100 to 400)	UL	12 Pin SSOP
-----------	---	------	----	----------	----	------------------	----	-------------



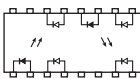



## High Linearity Analog Signal Optocoupler

Part Number	Pin Connections	Bandwidth (kHz)	Absolute Maximum Ratings		Linearity		Safety Certification	Package Style
			BV (V <sub>r.m.s.</sub> )	I <sub>F</sub> (mA)	MAX	Temperature Coefficient		
PS8741		200	1500	50	1%	.0005% / °C	UL, BSI	16 Pin SSOP

# Darlington Transistor, General Purpose Optocouplers

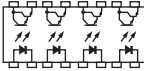



DC Devices, High Isolation Voltage

CTR measured @  $V_{CE} = 2V$ ,  $I_F = 1mA$

Part Number	Pin Connections	Absolute Maximum Ratings				CTR (%) (N = Full Range) Rank	Safety Certification	Package Style
		BV (V <sub>r.m.s.</sub> )	V <sub>CEO</sub> (V)	I <sub>F</sub> (mA)	I <sub>C</sub> (mA)			
PS2502-1		5000	40	80	200	<b>(N = 200 min)</b> K = 2000 min. L = 700 to 3400 M = 200 to 1000	UL	4 Pin DIP or L SMT
PS2502-2		5000	40	80	160	<b>(N = 200 min.)</b>	UL	8 Pin DIP or L SMT
PS2502-4		5000	40	80	160	<b>(N = 200 min)</b>	UL	16 Pin DIP or L SMT
PS2702-1		3750	40	50	200	<b>(N = 200 min)</b> K = 2000 min. L = 700 to 3400 M = 200 to 1000	UL, VDE, BSI	4 Pin SOP
PS2802-1		2500	40	50	90	<b>(N = 200 min)</b> K = 2000 min. L = 700 to 3400 M = 200 to 1000	UL, VDE, BSI	4 Pin SSOP
PS2802-4		2500	40	50	100	<b>(N = 200 min)</b>	UL, VDE, BSI	16 Pin SSOP

AC Devices, High Isolation Voltage

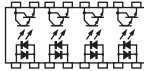
CTR measured @  $V_{CE} = 2V$ ,  $I_F = \pm 1mA$

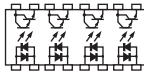
PS2506-1		5000	40	$\pm 80$	200	<b>(N = 200 min)</b>	UL	4 Pin DIP or L SMT
PS2506-2		5000	40	$\pm 80$	160	<b>(N = 200 min)</b>	UL	8 Pin DIP L SMT
PS2506-4		5000	40	$\pm 80$	160	<b>(N = 200 min)</b>	UL	16 Pin DIP or L SMT
PS2706-1		3750	40	$\pm 50$	200	<b>(N = 200 min)</b>	UL, VDE, BSI	4 Pin SOP
PS2806-1		2500	40	$\pm 50$	90	<b>(N = 200 min)</b>	UL, VDE, BSI	4 Pin SSOP
PS2806-4		2500	40	$\pm 50$	100	<b>(N = 200 min)</b>	UL, VDE, BSI	16 Pin SSOP

## Darlington Transistor Optocouplers, Guaranteed 0.4mm Insulation (BSI)

DC Devices, High Isolation Voltage

CTR measured @  $V_{CE} = 2V$ ,  $I_F = 1mA$

Part Number	Absolute Maximum Ratings Pin Connections	CTR (%)				(Full Range) Rank	Safety Certification	Package Style
		BV (V <sub>r.m.s.</sub> )	V <sub>CEO</sub> (V)	I <sub>F</sub> (mA)	I <sub>C</sub> (mA)			
PS2562-1		5000	40	80	200	(N = 200 min.) K = 2000 to 3400 L = 700 to 3400 M = 200 to 1000	UL, VDE, BSI	4 Pin DIP or L, L1, L2 SMT

AC Devices, High Isolation Voltage









CTR measured @  $V_{CE} = 2V$ ,  $I_F = 1mA$

PS2566-1		5000	40	±80	200	(N = 200 min.)	UL, VDE, BSI	4 Pin DIP or L, L1, L2 SMT
----------	---	------	----	-----	-----	----------------	-----------------	-------------------------------

## Darlington Transistor, High V<sub>CEO</sub> Optocouplers

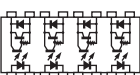
DC Devices

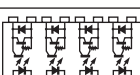
CTR measured @  $V_{CE} = 2V$ ,  $I_F = 1mA$

Part Number	Pin Connections	Absolute Maximum Ratings				CTR (%) (N = Full Range) Rank	Safety Certification	Package Style
		BV (V <sub>r.m.s.</sub> )	V <sub>CEO</sub> (V)	I <sub>F</sub> (mA)	I <sub>C</sub> (mA)			
PS2532-1		5000	300	80	150	(N = 1500 to 6500)	UL, VDE, BSI	4 Pin DIP or L SMT
PS2533-1		5000	350	80	150	(N = 1500 to 6500)	UL, VDE, BSI	4 Pin DIP or L SMT
PS2732-1		2500	300	50	150	(N = 1500 min)	UL, VDE, BSI	4 Pin SOP
PS2733-1		2500	350	50	150	(N = 1500 min)	UL, VDE, BSI	4 Pin SOP
PS2832-1		2500	300	50	60	(N = 400 to 4500)	UL, VDE, BSI	4 Pin SSOP
PS2832-4		2500	300	50	60	(N = 400 to 4500)	UL, VDE, BSI	16 Pin SSOP
PS2833-1		2500	350	50	60	(N = 400 to 4500)	UL	4 Pin SSOP
PS2833-4		2500	350	50	60	(N = 400 to 4500)	UL	16 Pin SSOP
PS2932-1		2500	300	50	60	(N = 400 to 4500)	UL, VDE, BSI	4 Pin Mini Flat
PS2933-1		2500	350	50	60	(N = 400 to 4500)	UL, VDE, BSI	4 Pin Mini Flat

**4 Pin DIP**

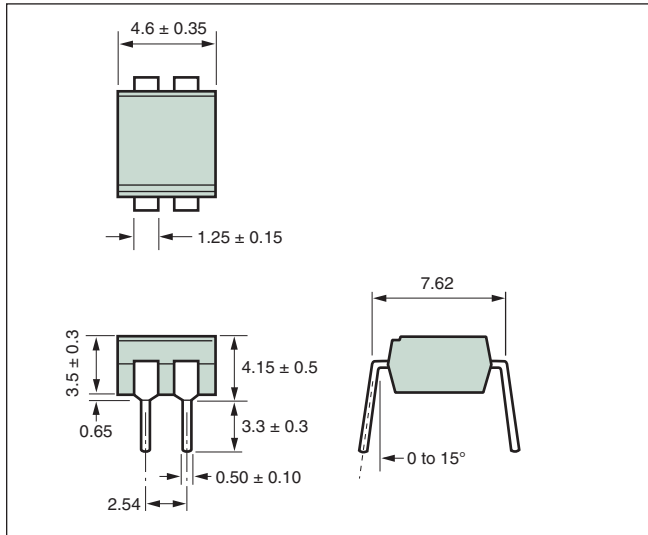

**4 Pin DIP L1 Surface Mount**

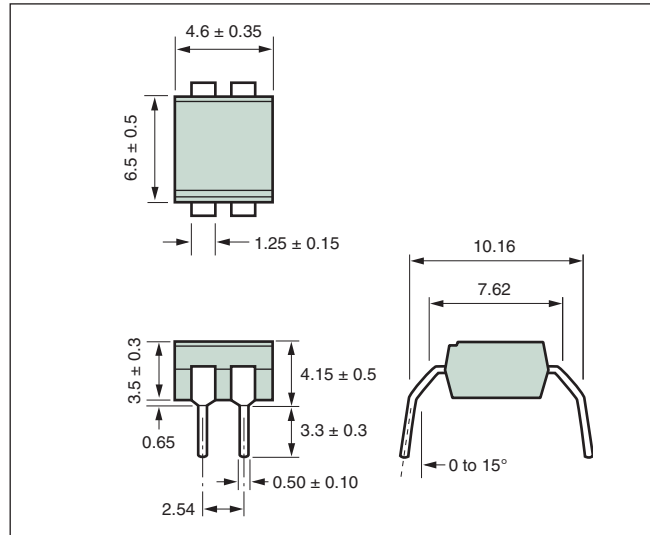

**4 Pin DIP L Surface Mount**

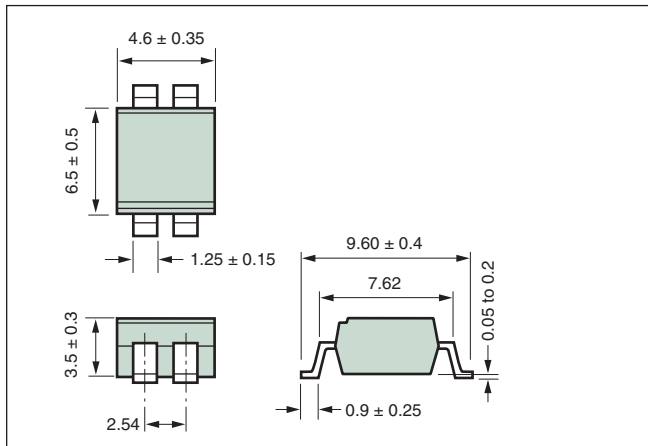

**4 Pin DIP L2 Surface Mount**

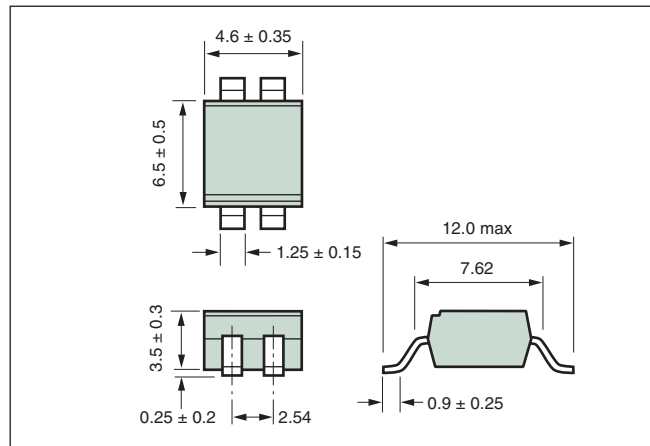

**4 Pin DIP L1 Surface Mount 8mm Creepage**

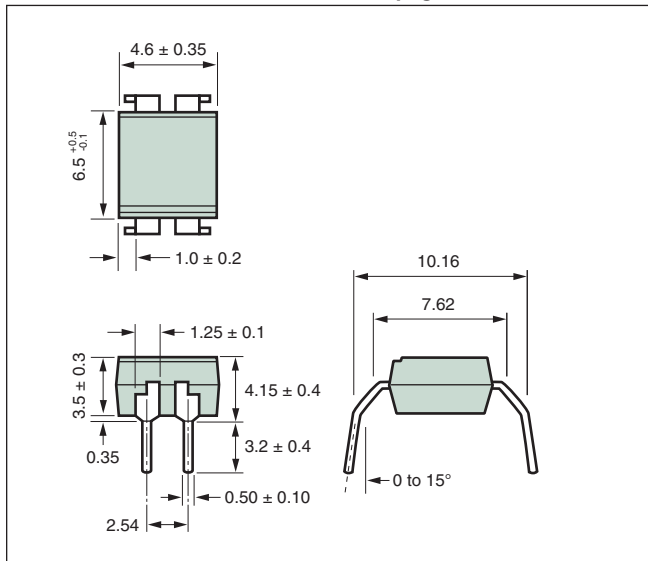

**4 Pin DIP L2 Surface Mount 8mm Creepage**

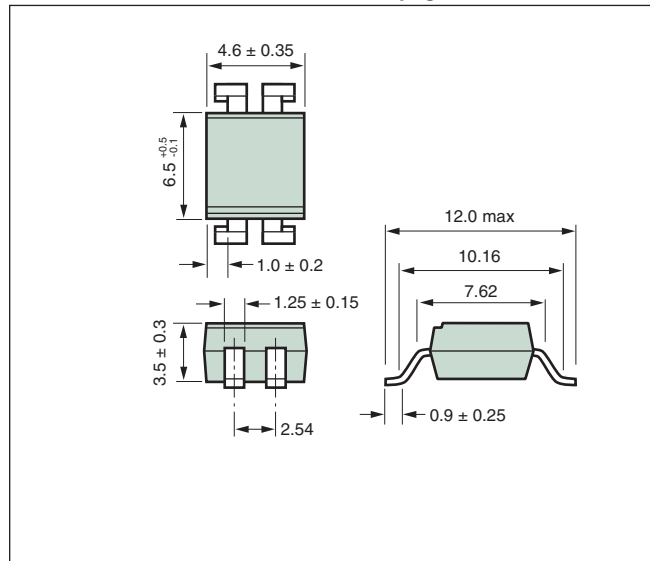

**8 Pin DIP**

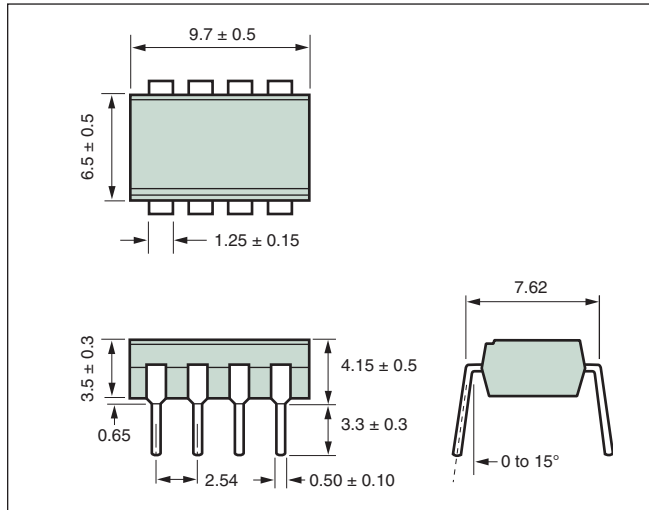

**8 Pin DIP L1**

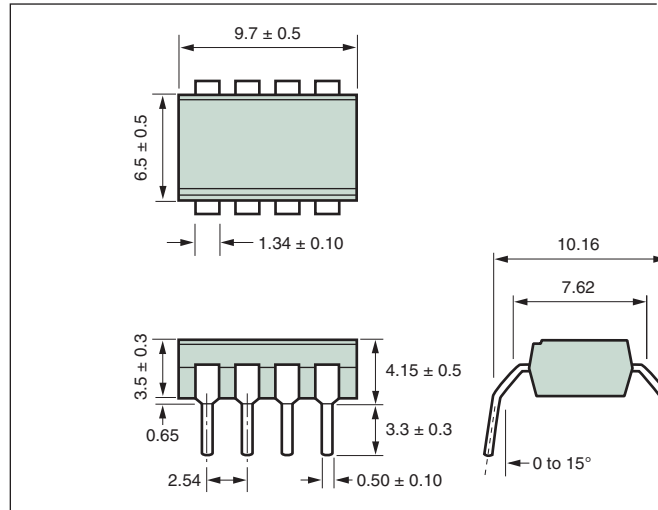

**8 Pin DIP L**

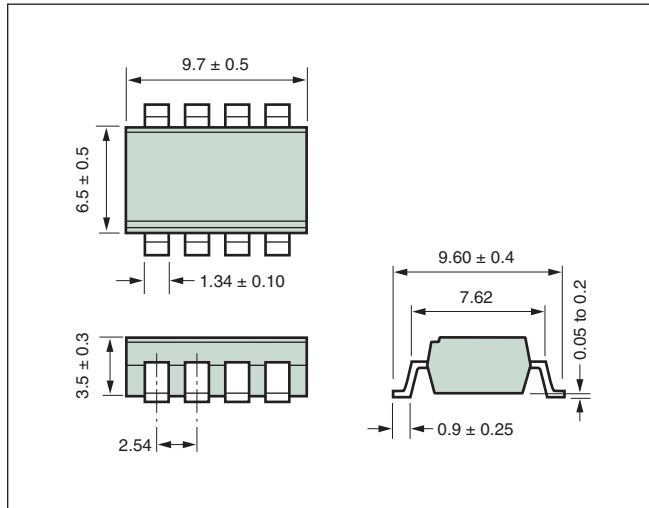

**8 Pin DIP L2**

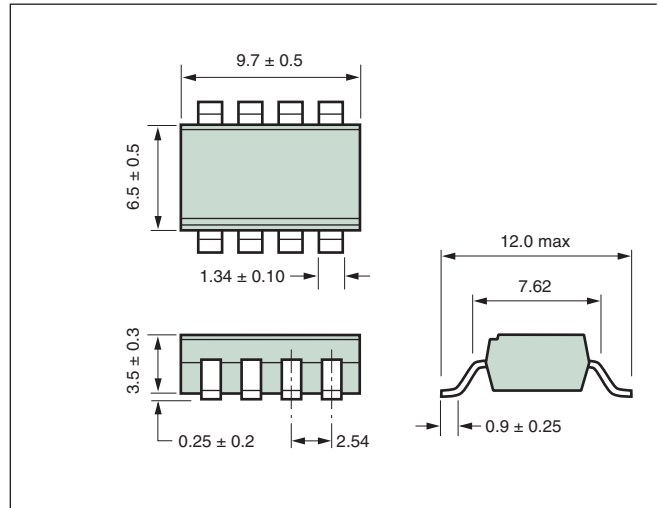

**8 Pin DIP L1 Surface Mount 8mm Creepage**

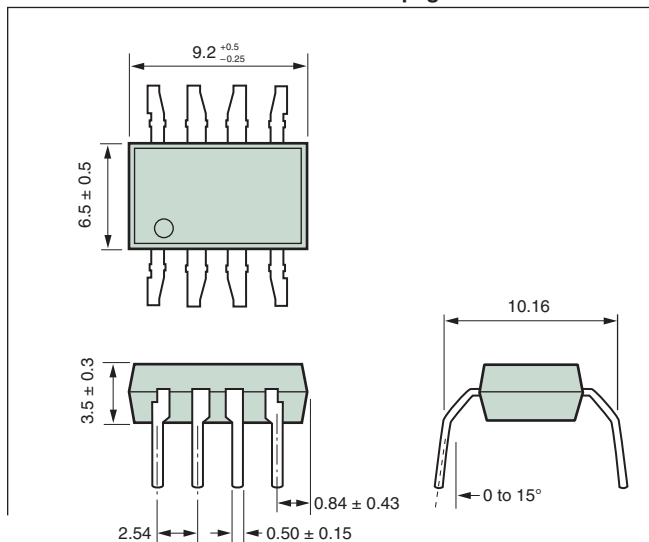

**8 Pin DIP L2 Surface Mount 8mm Creepage**

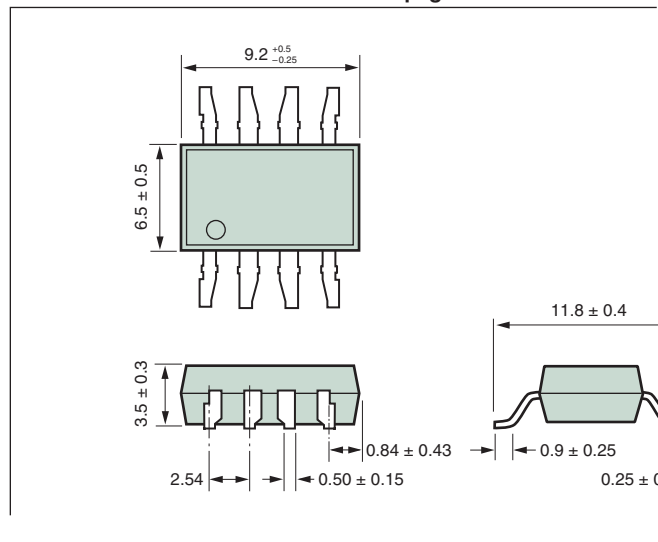

**16 Pin DIP**

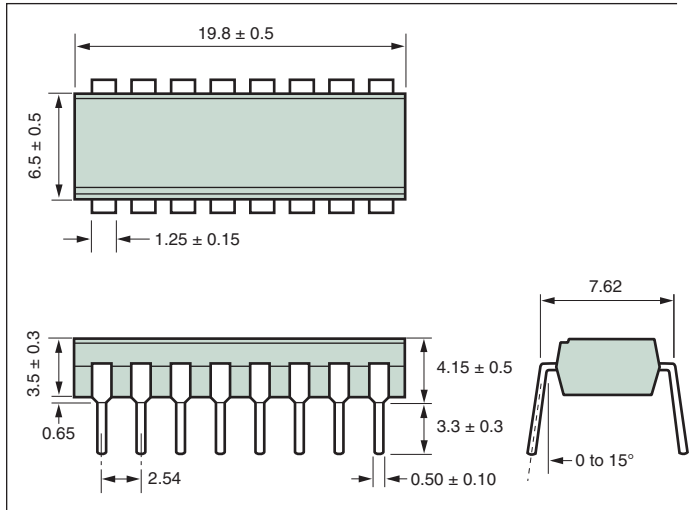

**16 Pin DIP L**

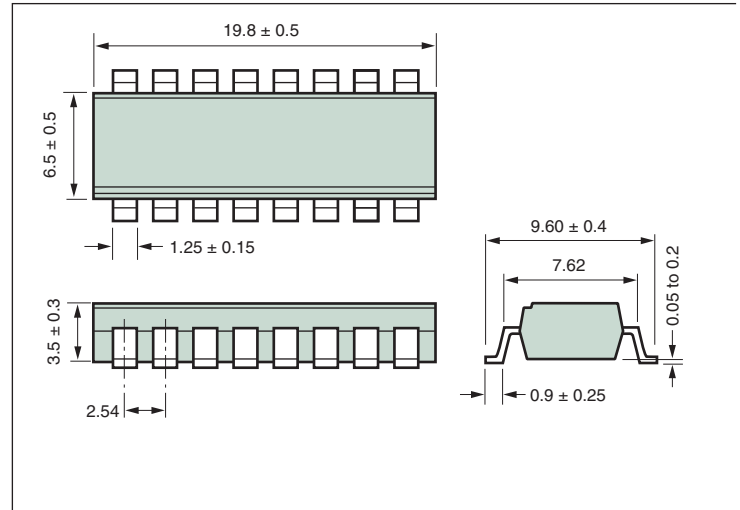

**4 Pin SOP 2.54mm pin pitch**

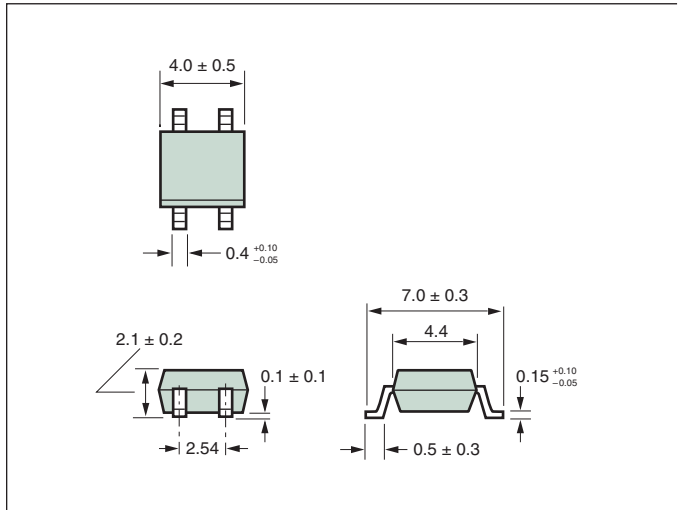

**4 Pin SSOP 1.27mm pin pitch**

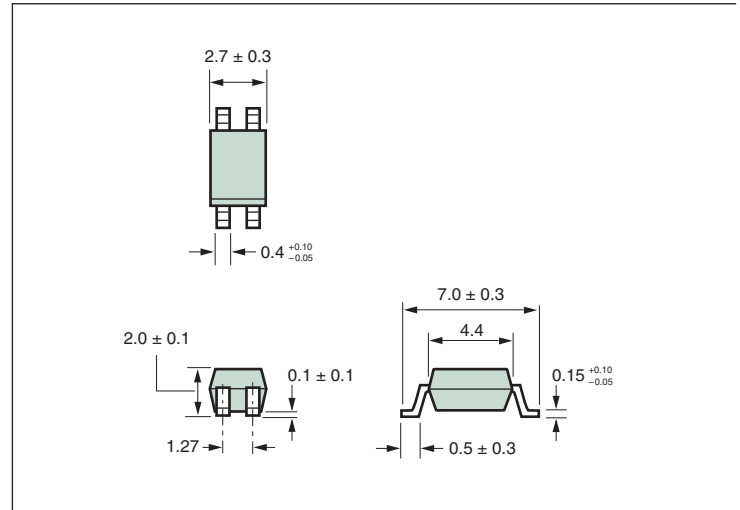

**5 Pin SOP 1.27mm pin pitch**

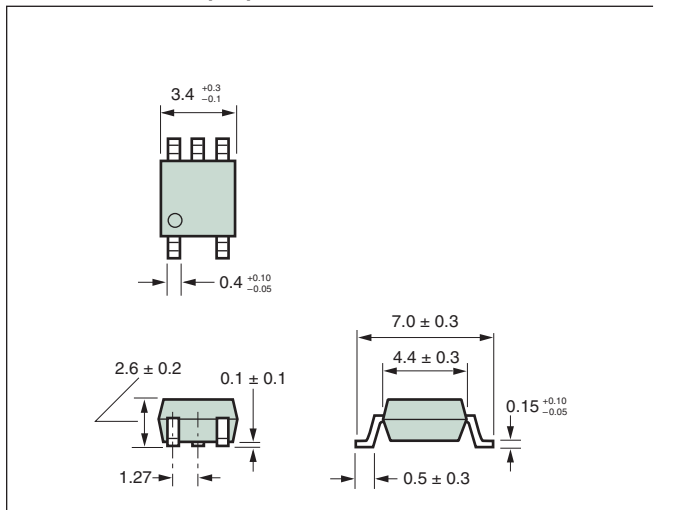

**5 Pin SOP 1.27mm pin pitch 5.5mm Creepage**

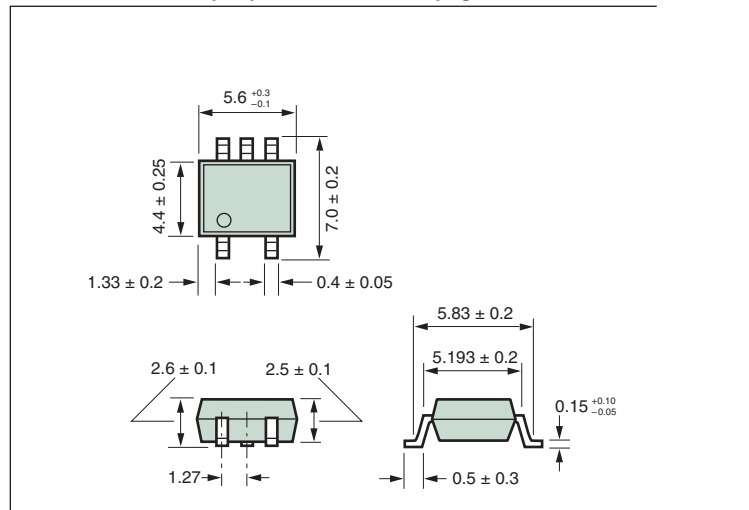



**S08 1.27mm pin pitch**

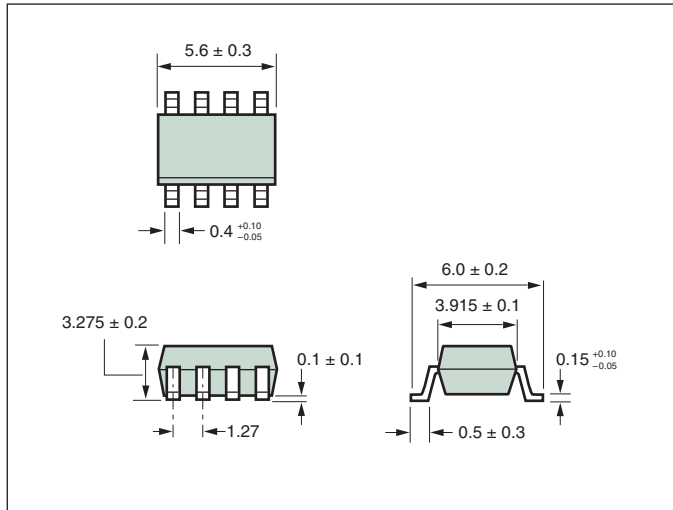

**12 Pin SSOP 1.27mm pin pitch**

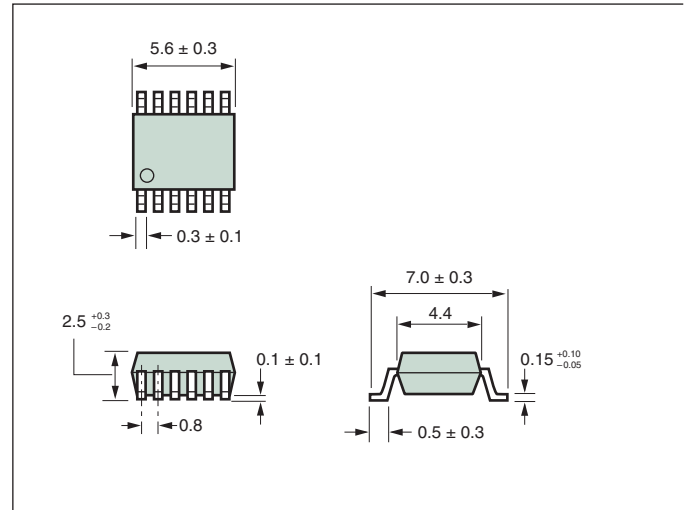

**16 Pin SSOP 1.27mm pin pitch**

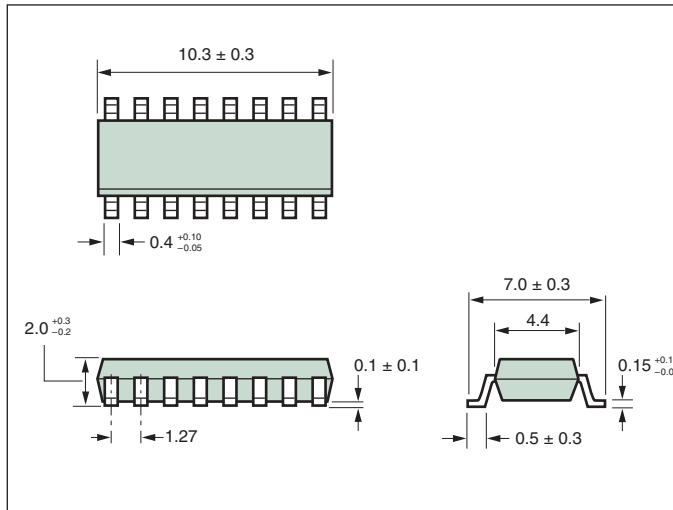

**4 Pin Mini Flat**

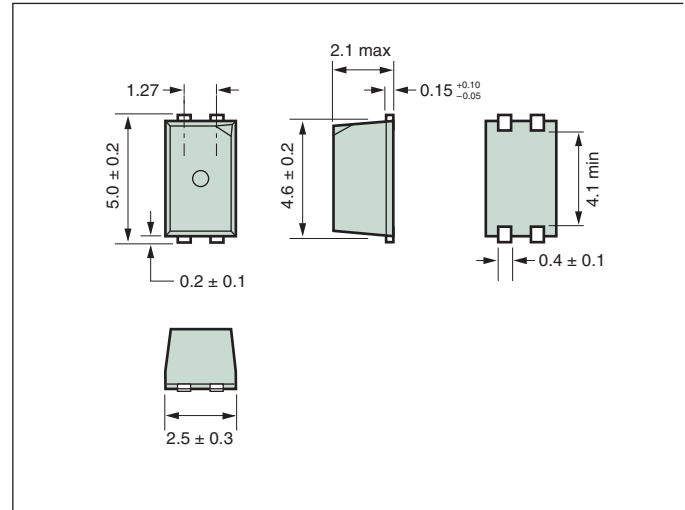

**CEL Headquarters**

4590 Patrick Henry Drive  
Santa Clara CA 95054  
Tel: (408) 919-2500  
Fax: (408) 988-0279

**www.cel.com**

**CEL West/Central**

Olathe, KS  
(913) 780-1380

**CEL South**

Snellville, GA  
(770) 978-4443

**CEL Northeast**

Baltimore, MD  
(410) 682-4111

**CEL Office for  
Distribution Partners**

Irvine, CA  
(949) 829-8300

**CEL Automotive and  
MobileComm Sales**

Wauconda, IL  
(847) 487-9906

**REPRESENTATIVES**

**Northwest**

Disman Bakner  
(800) 347-3010

**Colorado/Utah**

Albright Engineering  
(303) 877-9524

**Illinois**

SCC (847) 781-4010

**Wisconsin**

SCC (608) 882-0686

**Indiana/Kentucky**

TMC (317) 844-8462

**Michigan**

TMC (586) 731-3016

**Ohio**

TMC – Cincinnati  
(513) 984-6720

**CEL International  
Sales Office**

Hackettstown, NJ  
(908) 850-7600

**Canada**

*BC, Alberta, Saskatchewan*  
Disman Bakner  
(800) 347-3010

*Manitoba*

CEL West/Central Sales  
(913) 780-1380

*Western & Central Ontario*

E-Cubed Components  
(905) 791-0812

*Ottawa & Eastern Ontario*

Brian Turner & Associates  
(613) 254-9024

*Quebec & Maritime Provinces*

CEL Northeast Sales  
(410) 682-4111

**Mexico**

*Zapopan, Jalisco*  
VLA Solutions  
+(52) 333-836-6323

*Tijuana*

VLA Solutions  
(925) 284-1606

**South America**

VLA Solutions  
+(55) 115-505-8011

**Israel**

Semix Engineering  
and Marketing, Ltd.  
+(972) 3-979-7020

**India**

International Marketing Services  
+(91) 80-2286-4005/1979

**Singapore**

CEL Administrative Office  
+(65) 6-560-3255

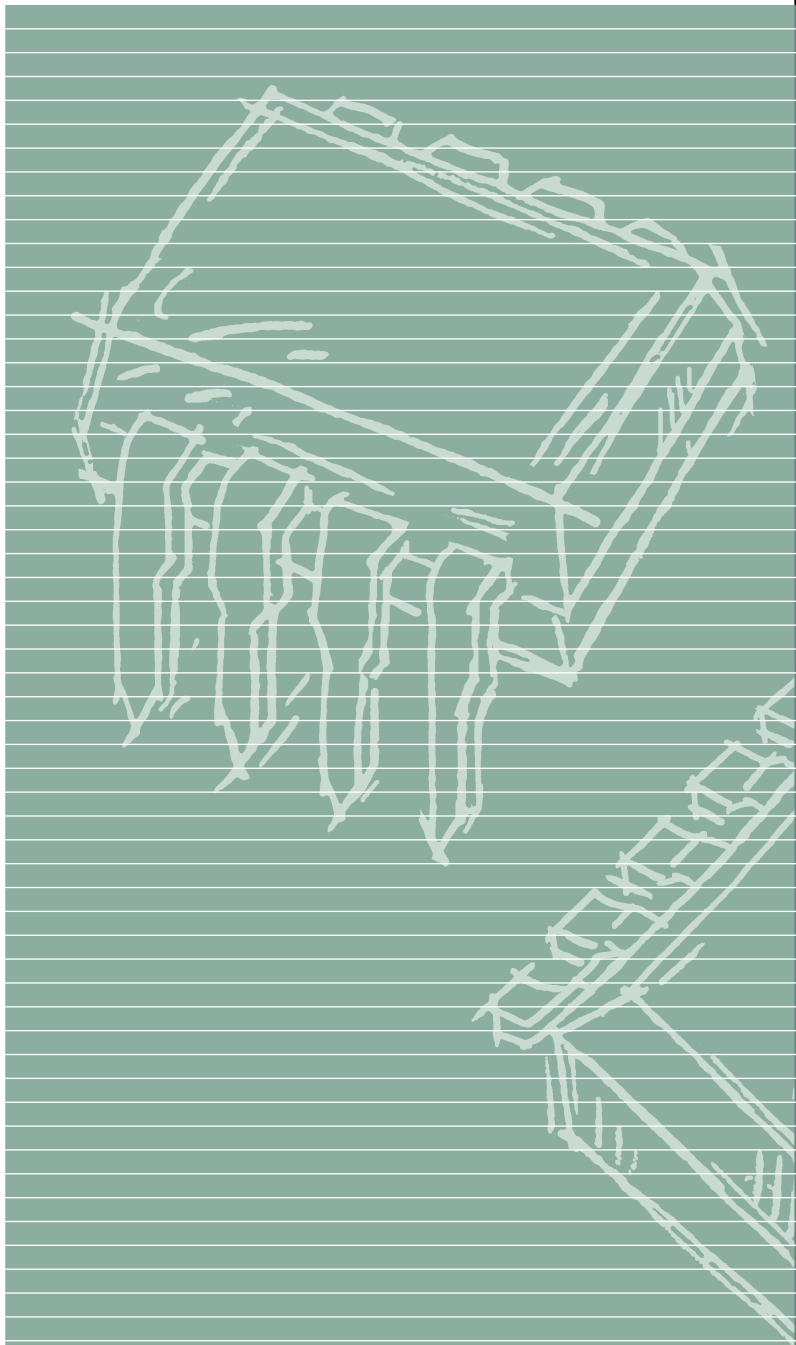

A Business Partner of NEC Electronics Corporation.

NEC is a trademark of NEC Corporation.