

KSC Series Sealed Tact Switch for SMT

Features/Benefits

- Positive tactile feeling
- Range of 6 actuation forces
- J or G terminations
- Tape & reel
- IP 67

Typical Applications

- Automotive
- Cellular phones
- Industrial electronics
- Network infrastructure and IT



Specification

FUNCTION: Momentary action
CONTACT ARRANGEMENT: 1 make contact = SPST, N.O.
TERMINALS: J bend & Gullwing type for SMT

Mechanical

Type	Operating force FA (Newtons) Min/Max	Operating life (operations)	Travel (mm)
KSC121J	1.2 / 2.5	200,000	0.3 ± 0.15
KSC141J	2.25 / 3.75	200,000	0.3 ± 0.15
KSC151J	4.1 / 6.9	100,000	0.35 ± 0.15
KSC201J	0.9 / 2.0	300,000	0.3 +0.2 / -0.15
KSC221J	1.5 / 2.5	500,000	0.35 +0.3 / -0.1
KSC222J	1.5 / 2.5	1,000,000	0.35 +0.3 / -0.1
KSC241J	2.6 / 4.4	300,000	0.5 ± 0.2
KSC251J	4.1 / 7.0	300,000	0.5 ± 0.2
KSC321J	1.6 / 2.4	300,000	0.2 +0.3 / 0
KSC341J	2.25 / 3.75	300,000	0.2 +0.3 / 0
KSC351J	4.0 / 6.0	100,000	0.25 +0.3 / 0
KSC401J 50SH	0.82 / 1.38	1,000,000	0.3 ± 0.15
KSC411J 70SH	1.05 / 1.75	1,000,000	0.35 ± 0.20
KSC421J 70SH	1.25 / 2.12	300,000	0.5 ± 0.25
KSC422J 70SH	1.25 / 2.12	1,000,000	0.5 ± 0.25
KSC441J 70SH	3.0 / 5.0	300,000	0.75 ± 0.25
KSC442J 70SH	3.0 / 5.0	1,000,000	0.75 ± 0.25
KSC621J	1.0 / 1.65	300,000	0.5 ± 0.2
KSC641J	2.25 / 3.75	300,000	0.5 ± 0.2
KSC421V	1.4 / 2.2	300,000	0.375 ± 0.225
KSC621V	1.1 / 1.9	100,000	0.5 ± 0.2
KSC721 J	1.7 / 2.8	300,000	0.3 ± 0.15
KSC741J	2.9 / 4.9	300,000	0.4 ± 0.20

A detect switch version is available KSC4D1J and KSC4D1G.
Please see Detect chapter.
KSC vertical series have an IP40 sealing level.

Electrical

	Silver	Gold
MAXIMUM POWER:	1 VA	0.2 VA
MAXIMUM VOLTAGE:	32 VDC	32 VDC
MINIMUM VOLTAGE:	20 mV	20 mV
MAXIMUM CURRENT:	50 mA	10 mA
MINIMUM CURRENT:	1 mA	1 mA

DIELECTRIC STRENGTH (50 Hz, 1 min.): 250 V
CONTACT RESISTANCE: < 100 mΩ
INSULATION RESISTANCE (100 V): > 10⁹ Ω
BOUNCE TIME: < 1 ms

Environmental

	Silver	Gold
OPERATING TEMPERATURE:	-40°C to 85°C	-40°C to 125°C
STORAGE TEMPERATURE:	-55°C to 85°C	-55°C to 125°C

Process

SOLDERING: Depending on the application, this component is suited to the following methods:

- Terminals being silver or gold plated over a nickel barrier, the use of slightly activated flux is suitable.
- Soldering on double wave machine for vertical versions: soldering time < 5 sec.
- Cleaning according to typical washing processes.
- Infrared Reflow Soldering in accordance with IEC 61760-1.

Packaging

KSC1, KSC2 and KSC3 are delivered on continuous tape and reels of 2,000 pieces, KSC4 in reels of 1,000 pieces. KSC 6 in reels of 750 pieces. KSC7 in reels of 1,000 pieces. KSCV in boxes of 500 pieces. Dimensions of reels according to EIA RS481 or IEC 2863. External diameter 330 mm ± 2 mm.

NOTE: Specifications listed above are for switches with standard options. For information on specific and custom switches, consult Customer Service Center.

Other versions in terms of force, termination length and corrosion protection available. Please contact your sales representative.

This data sheet does not provide enough information for applications which require a certain level of quality or safety such as automotive, medical systems, safety equipment. Please contact your sales representative to get contractual specification package.

How To Order

Our easy build-a-switch concept allows you to mix and match options to create the switch you need. To order, select desired option from each category and place it in the appropriate box.

For any part number different from those listed above, please consult your local representative.

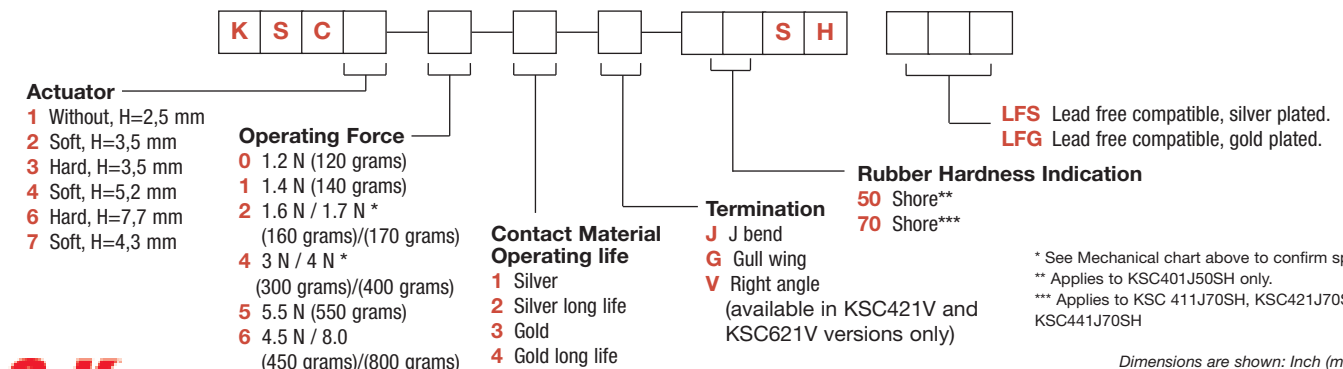

KSC Series Sealed Tact Switch for SMT

ACTUATOR

KSC1 WITHOUT, 2,5 mm HIGH

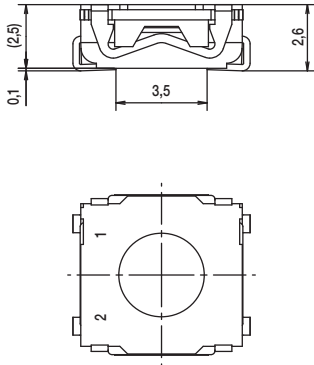

KSC2 SOFT, 3,5 mm HIGH

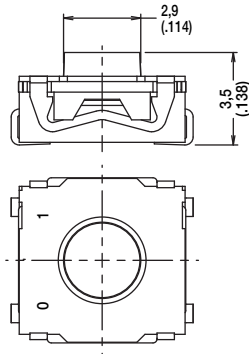

KSC3 HARD, 3,5 mm HIGH

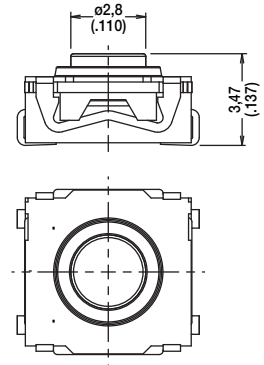

Tactile Switches

KSC4 SOFT, 5,2 mm HIGH

NOTE: KSC4 standard silicone material is 70 shore, the only exception is KSC401J which is 50 shore.

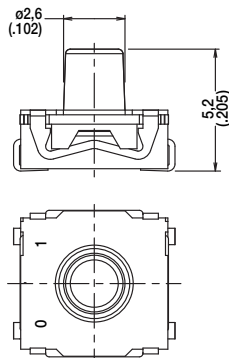

KSC4 KSC421V ONLY

NOTE: KSC421V requires metalized holds for simultaneous reflow soldering of switch terminals and bracket terminals.

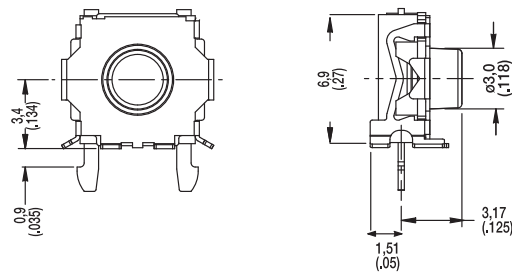

KSC6 HARD, 7,7 mm HIGH

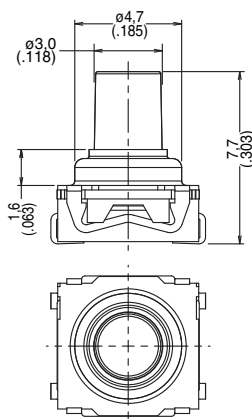

KSC6 KSC621V ONLY

NOTE: KSC621V requires metalized holds for simultaneous reflow soldering of switch terminals and bracket terminals.

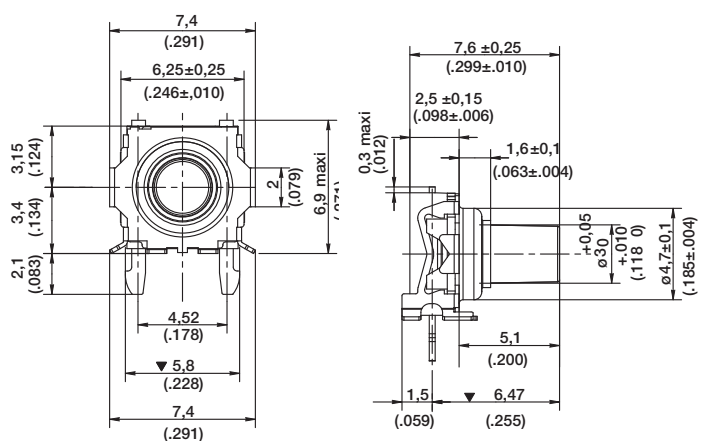

Dimensions are shown: Inch (mm)
Specifications and dimensions subject to change

KSC Series Sealed Tact Switch for SMT

KSC7 SOFT, 4,3 mm HIGH

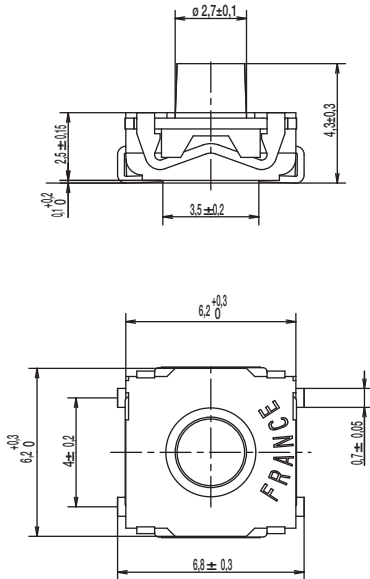

B

Tactile Switches

OPERATING FORCE



OPTION CODE	OPERATING FORCE
0	1.2 N (120 grams)
1	1.4 N (140 grams)
2	1.6 N / 1.7 N (160/170 grams)
4	3 N / 3.5 N (300/350 grams)
5	5.5 N (550 grams)

CONTACT MATERIAL



OPTION CODE	MATERIAL
1	SILVER
3	GOLD

KSC Series Sealed Tact Switch for SMT

TAPE & REEL

FOR KSC1 J TERMINATION

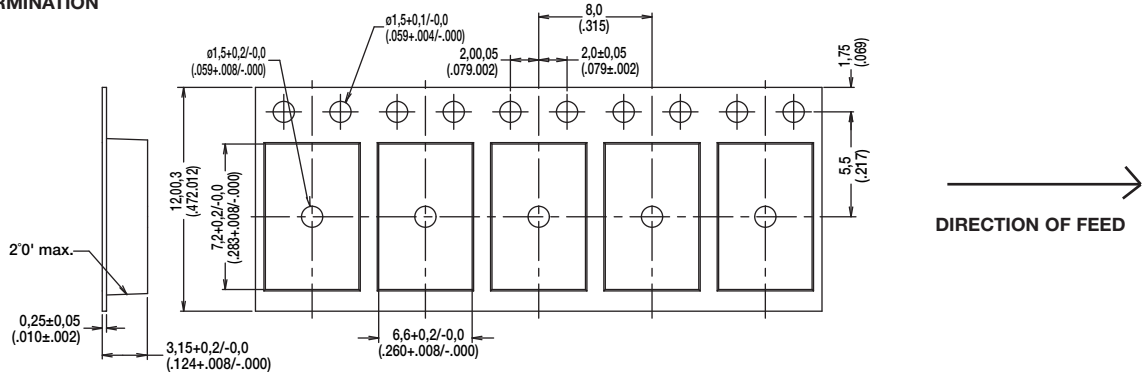

FOR KSC1 G TERMINATION

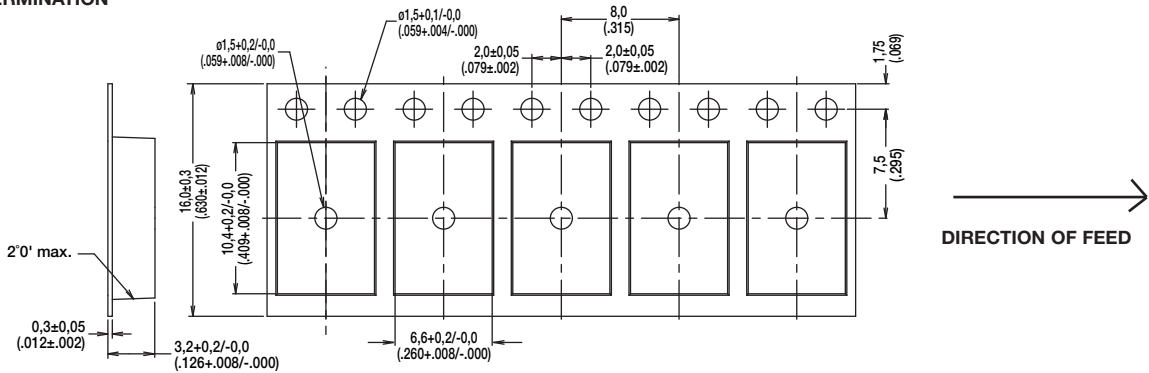

FOR KSC2 & KSC3 J TERMINATION

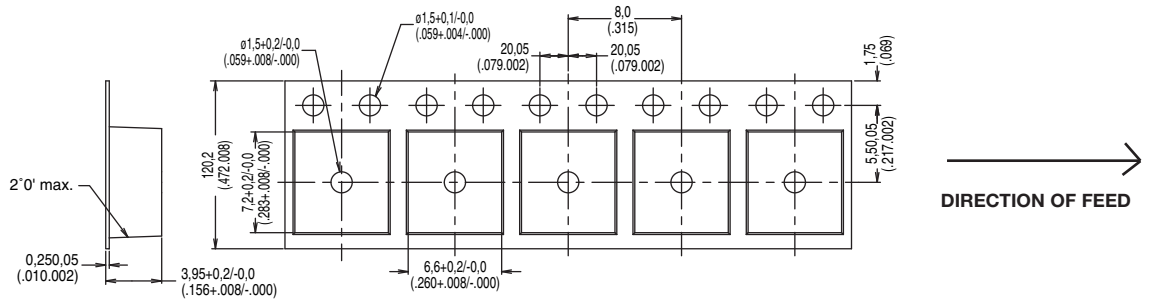

FOR KSC2 & KSC3 G TERMINATION

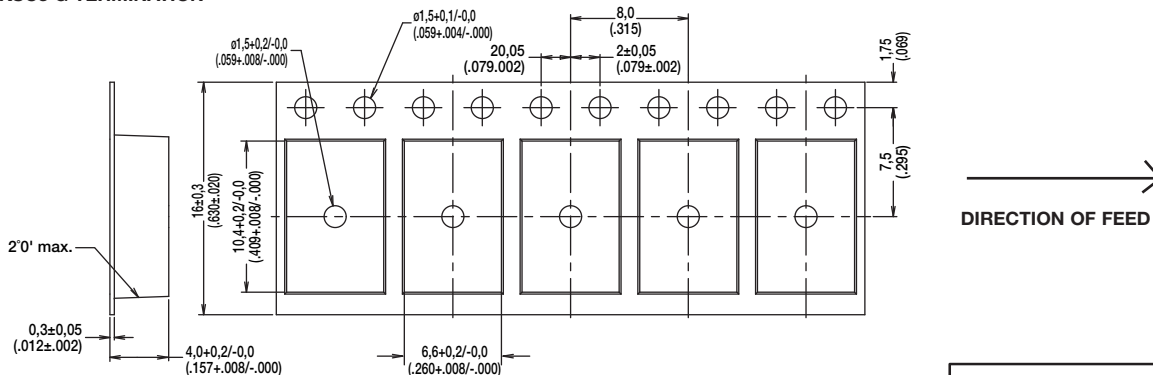

Dimensions are shown: Inch (mm)
Specifications and dimensions subject to change



KSC Series Sealed Tact Switch for SMT

TAPE & REEL

FOR KSC4 FOR G TERMINATION

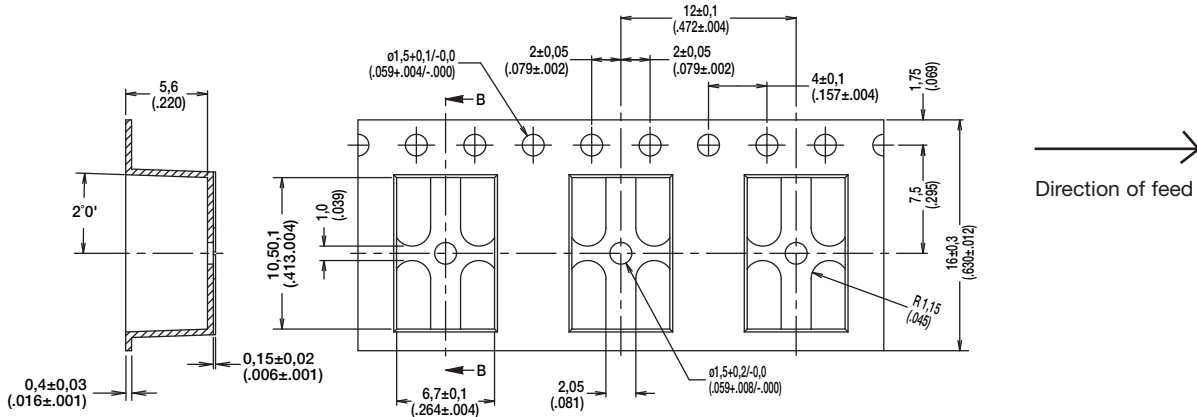

FOR KSC4 FOR J TERMINATION

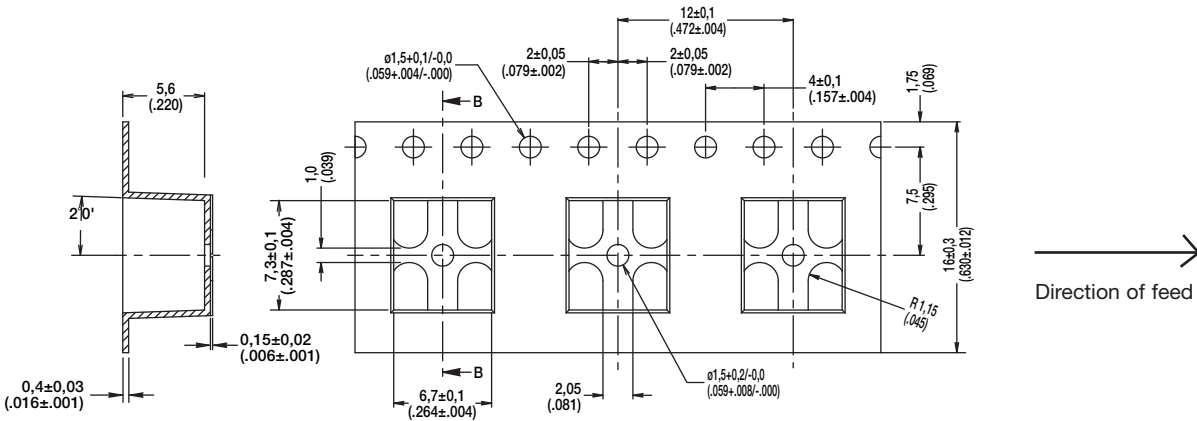

FOR KSC6 G & J TERMINATION

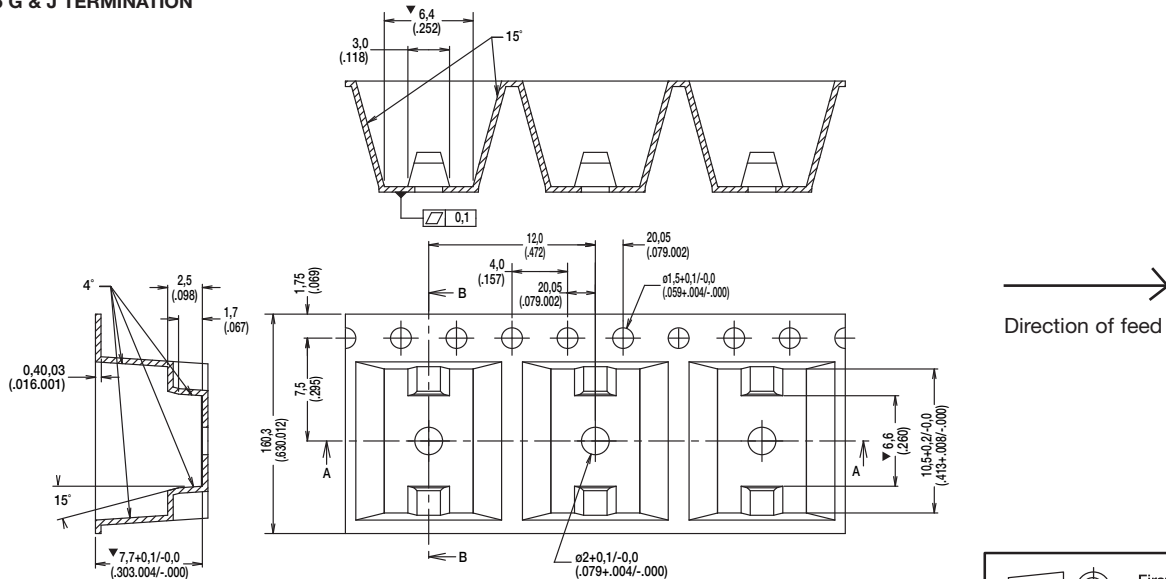

Dimensions are shown: Inch (mm)
Specifications and dimensions subject to change

KSC Series Sealed Tact Switch for SMT

TAPE & REEL

FOR KSC7 FOR J TERMINATION

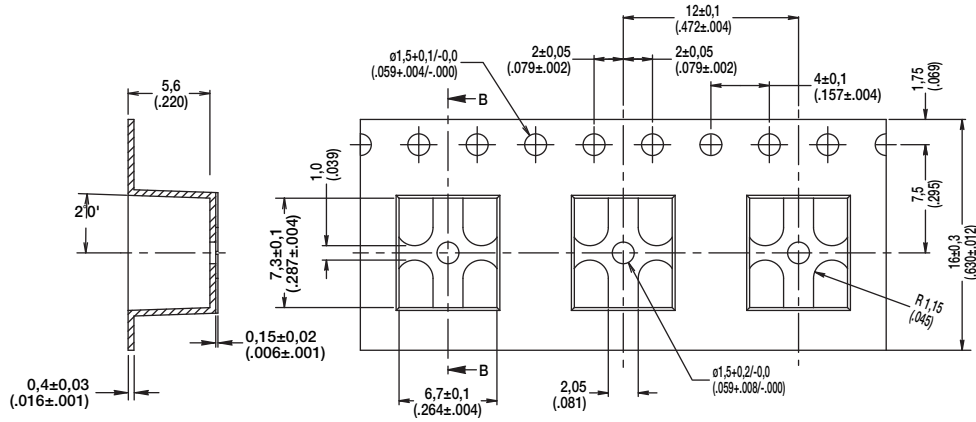

B

Tactile Switches



Dimensions are shown: Inch (mm)
Specifications and dimensions subject to change