

SPECIFICATION

CJ406
CJ420B

SMART QUAD SWITCH

The CJ406/CJ420B consists of four identical low side power switches. A serial diagnostic interface indicates failure mode of each switch (short circuit to V_{BAT} or ground and open load, overtemperature only for CJ420B).

FEATURES

- Modified VDMOS Power Stage ($U_{DSBR} > 80\text{ V}$)
- $R_{DS(ON)} < 500\text{ m}\Omega$ ($T_J = 25^\circ\text{ C}$)
- CMOS Compatible Inputs
- Enable Input (Reset)
- Outputs Capable of up to 2.2 Amperes
- Outputs Internally Clamped at 70V for Fast Inductive Load Switch Off
- wide operating supply voltage from 4.7V up to 30V

DIAGNOSTIC FUNCTIONS

- Open Load Detection (Output off, 100 μs - filtering time)
- Short to Ground Detection (Output off, 100 μs - filtering time)
- Short to Battery Detection (Output on)
- Only CJ420B: Overtemp. detection (Output on)
- Storage of last fault in 8 Bit - Serial Register
- Fault Signal Indication at Serial Data Out without need to read out the Serial Interface
- Daisy Chainable Serial Diagnostic
- Serial Interface Clock Frequency up to 500kHz

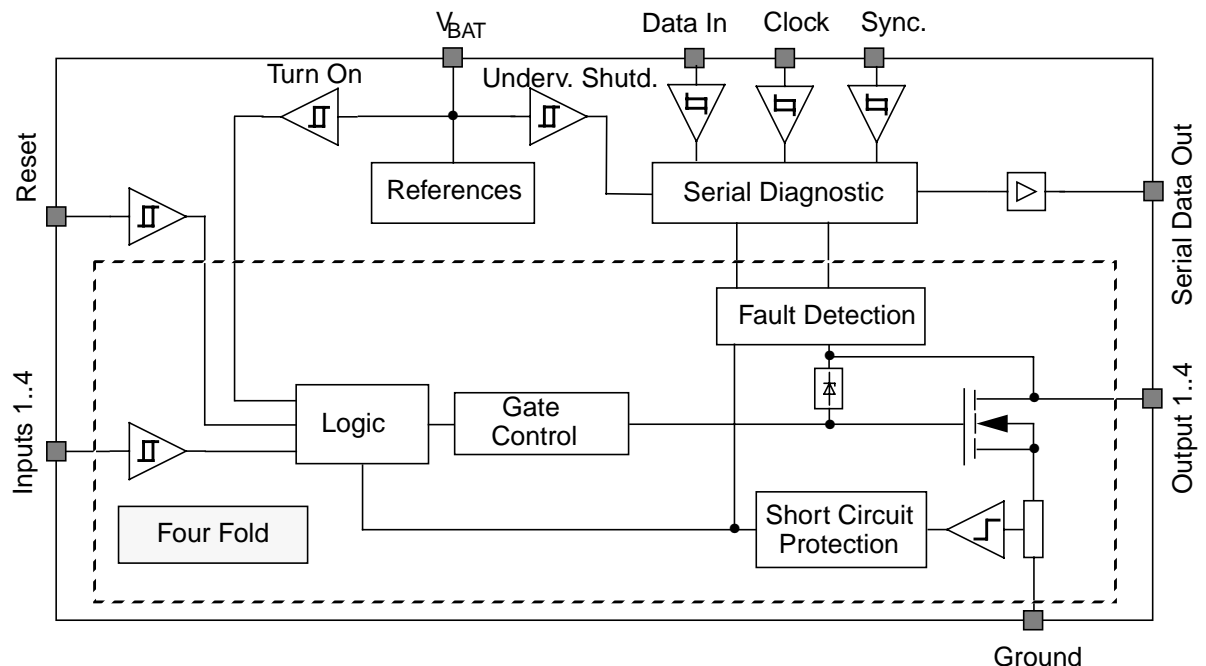

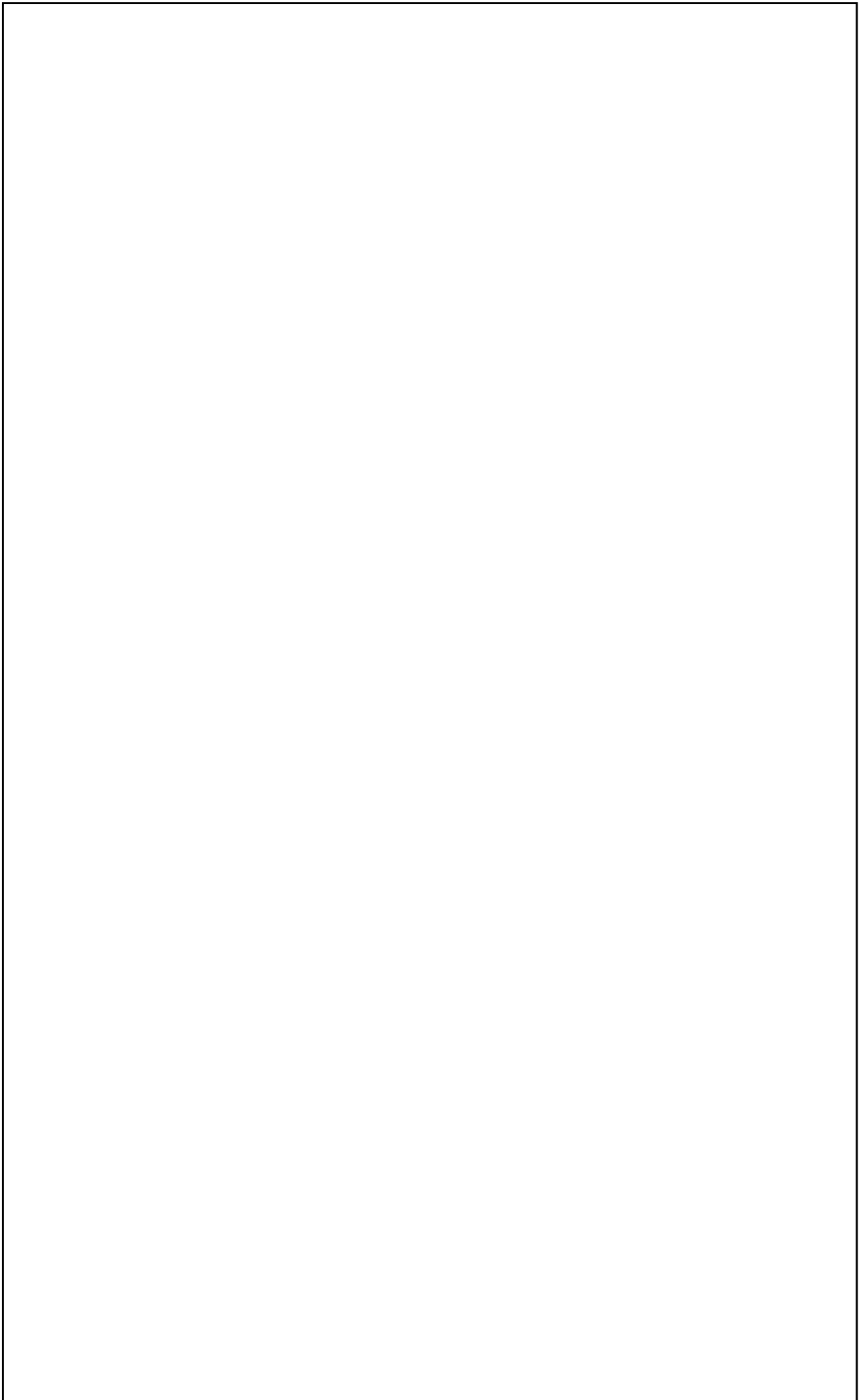

PIN CONNECTIONS

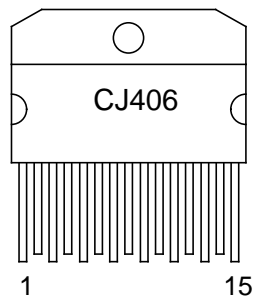

Multiwatt15

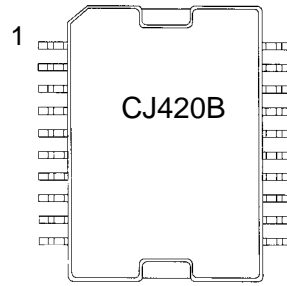

POWER-SO20

Pin Nr.	Function	Function
1	Input 1 IN1	Ground GND
2	Input 2 IN2	nc
3	Output 1 OUT1	Input 1 IN1
4	Supply Voltage VBAT	Input 2 IN2
5	Output 2 OUT2	Output 1 OUT1
6	Serial Data Out DO	Supply Voltage VBAT
7	Clock CL	Output 2 OUT2
8	Ground GND	Serial Data Out DO
9	Synchronisation SY	Clock CL
10	Serial Data In DI	Ground GND
11	Output 3 OUT3	Ground GND
12	Reset R	Synchronisation SY
13	Output 4 OUT4	Serial Data In DI
14	Input 3 IN3	Output 3 OUT3
15	Input 4 IN4	Reset R
16		Output 4 OUT4
17		Input 3 IN3
18		Input 4 IN4
19		nc
20		Ground GND

MAXIMUM RATINGS

Parameter	Conditions	Symbol	Min.	Typ.	Max.	Unit
Storage Temperature		T_{ST}	-55		150	°C
Operating Junction Temperature		T_J	-40		150	°C
DC Supply Voltage		V_{BAT}	-2		30	V
Transient Supply Voltage	$t < 400\text{ms}$	V_{BATtr}			40	V
Output Voltage		V_{OUT}			65	V
Transient Output Voltage	during clamping	V_{OUTtr}			78	V
Output Clamping energy	repetition rate < 100 Hz	E_{CL}			10	mJ
Output reverse current		$-I_{OUT}$			2	A
Control Input voltage		$V_R, V_{INi},$ V_{DI}, V_{CL} V_{SY}	-0.3		6.5	V
Control Output voltage		V_{DO}	-0.3		6.5	V

Thermal Resistance

Parameter	Conditions	Symbol	Min.	Typ.	Max.	Unit
Thermal Resistance junction - case Multiwatt 15		$R_{th\ j-c}$		2.5		K / W
Thermal Resistance junction - case POWER-SO 20		$R_{th\ j-c}$		2.5		K / W

ELECTRICAL CHARACTERISTICS

6.5V < V_{BAT} < 25V, -40 < T_J < 150°C

Parameter	Conditions	Symbol	Min.	Typ.	Max.	Unit
Supply Voltage						
Turn on threshold voltage		V _{BATU}	2.0		4.7	V
Supply current	V _{BAT} = 14V V _{OUTi} > 0V	I _{BAT}	5	10	15	mA
Output stage						
On resistance	U _{BAT} = 4.7V, T _J = 25°C, I _{out} = 0.5 A	R _{DSON}			800	mΩ
	T _J = 25°C I _{out} = 1A	R _{DSON}			500	mΩ
	T _J = 150°C I _{out} = 1A	R _{DSON}			850	mΩ
Clamping voltage, inductive load	I _{out} = 0.5 A	V _{CL}	63	70	76	V
Over current shutdown (Shutdown latch resets with pos. slope at INi)	T _J = -40°C	I _{OUTi}	3.0		4.3	A
	T _J = 25°C		2.5		3.7	A
	T _J = 150°C		2.2		3.5	A
Output leakage current see : Open load diagnostic current						

ELECTRICAL CHARACTERISTICS

6.5V < V_{BAT} < 25V, -40 < T_J < 150°C

Parameter	Conditions	Symbol	Min.	Typ.	Max.	Unit
Logic Inputs IN1 ... IN4, SY, CL,DI,R						
Input High level		V _{INiHL} V _{SYHL} V _{CLHL} V _{RiHL} V _{DIHL}	3.5		6.5	V
Input Low level		V _{INiLL} V _{SYHL} V _{CLHL} V _{RHL} V _{DIHL}	-0.3		1.5	V
Hysteresis		V _{INiH} V _{SYHL} V _{CLHL} V _{RHL} V _{DIHL}	0.2		1	V
Input current IN1 ... IN4, SY, CL, R (Internal pull up current source)	V _{INi} = 0V V _{SY} = 0V V _{CL} = 0V V _R = 0V	- I _{INi} - I _{SY} - I _{CL} - I _R	20	40	80	μA
Input current DI (Internal pull up current source)	V _{DI} = 0V	- I _{DI}	120	220	300	μA
Timing						
Turn on delay		t _{d_{on}}		7.5		μs
Turn off delay		t _{d_{off}}		7.5		μs
Switch on slew rate		s _{on}		10		V/μs
Switch off slew rate		s _{off}		15		V/μs
Over current detection time		t _{oc}		0.5		μs
Open load filtering time		t _v	60	100	200	μs
Short to GND filtering time		t _v	60	100	200	μs
Serial clock frequency		f _{CL}	0		500	kHz
DO: Datavalidtime		t _{vDV}	0.03		1	μs
DI: Datasettlingtime		t _{vset}	0.5			μs
DI: Dataholdtime		t _{vhold}	0			μs

ELECTRICAL CHARACTERISTICS

Parameter	Conditions	Symbol	Min.	Typ.	Max.	Unit
Diagnostic						
Undervoltage threshold		V_{BATDU}	4.7		7.5	V
Serial Data output (External pull up required)						
Data output low voltage	$I_{DO} < 1.6mA$ $7.5V < V_{BAT} < 22V$	V_{DO}	0		0.45	V
Data output leakage current		$ I_{DO} $			10	μA
Output voltage monitoring Output off						
Open load threshold voltage (fault detected if $V_{OUTi} < V_{OL}$)	$7.5V < V_{BAT} < 22V$	V_{OL}		$2/3V_{BAT}$		
Short to GND threshold voltage (fault detected if $V_{OUTi} < V_{SG}$)	$7.5V < V_{BAT} < 22V$	V_{SG}		$1/3V_{BAT}$		
Open load diagnostic current Output off						
Open load output voltage	$I_{OUT} = 0 A$ $V_{INi} = 5V$ $7.5V < V_{BAT} < 22V$			$1/2V_{BAT}$		
Output current	$V_{OUT} = 1V$ $V_{INi} = 5V$	$-I_{OUTi}$	50	100	150	μA
Output current	$V_{OUT} = V_{BAT}$ $V_{INi} = 5V$ $7.5V < V_{BAT} < 22V$	I_{OUTi}	200	320	500	μA
Overload Diagnostic						
Over temperature diagnostic (Only CJ 420B)	T_J			175		$^{\circ}C$
Over current	$T_J = -40^{\circ}C$ $T_J = 25^{\circ}C$ $T_J = 150^{\circ}C$	I_{OUTi}	3.0 2.5 2.2		4.3 3.7 3.5	A

TYPICAL TIMING DIAGRAM FOR SERIAL DIAGNOSTIC

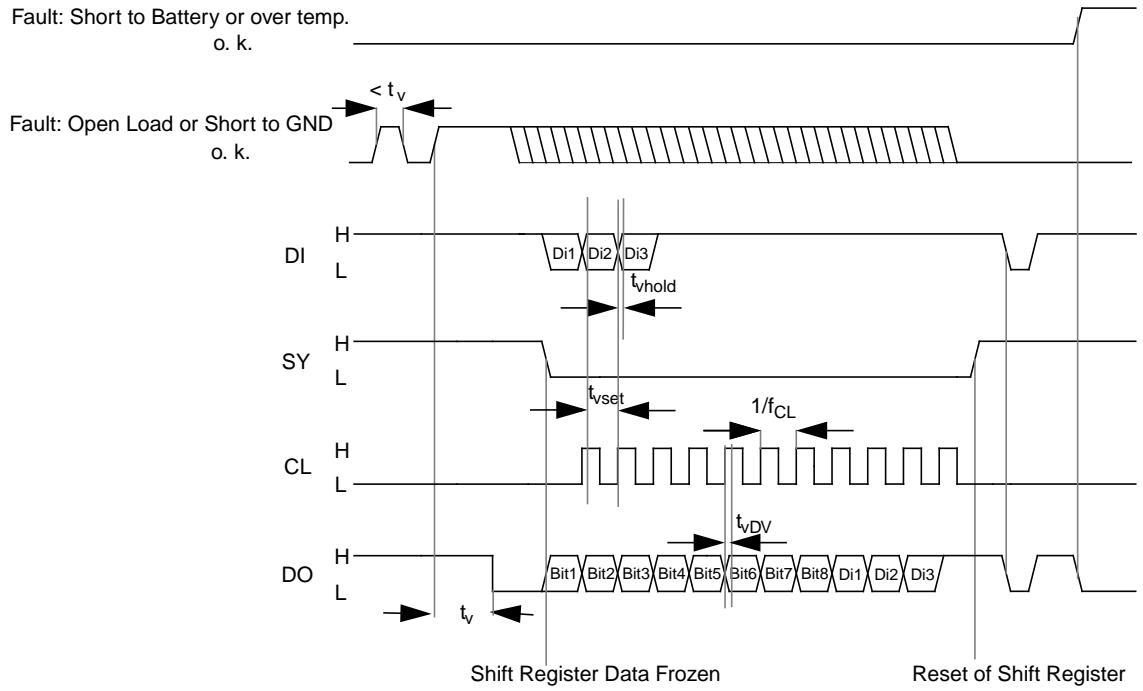

SERIAL INTERFACE ERROR CODING

BIT 1	BIT 2	BIT 3	BIT 4	BIT 5	BIT 6	BIT 7	BIT 8	BIT n
OUTPUT 1				OUTPUT 2		OUTPUT 3		DI

H	H	o.k.
L	H	open load/over temperature(only CJ420B)
H	L	short to battery
L	L	short to ground

OUTPUT VOLTAGE TIMING FOR INDUCTIVE LOAD

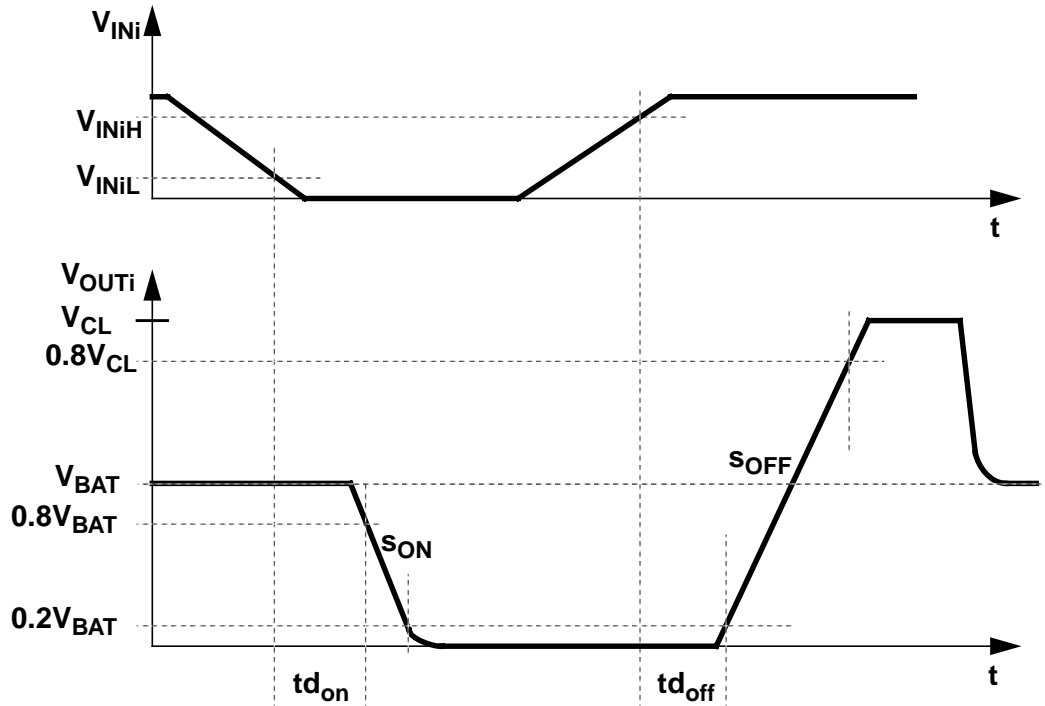

APPLICATION

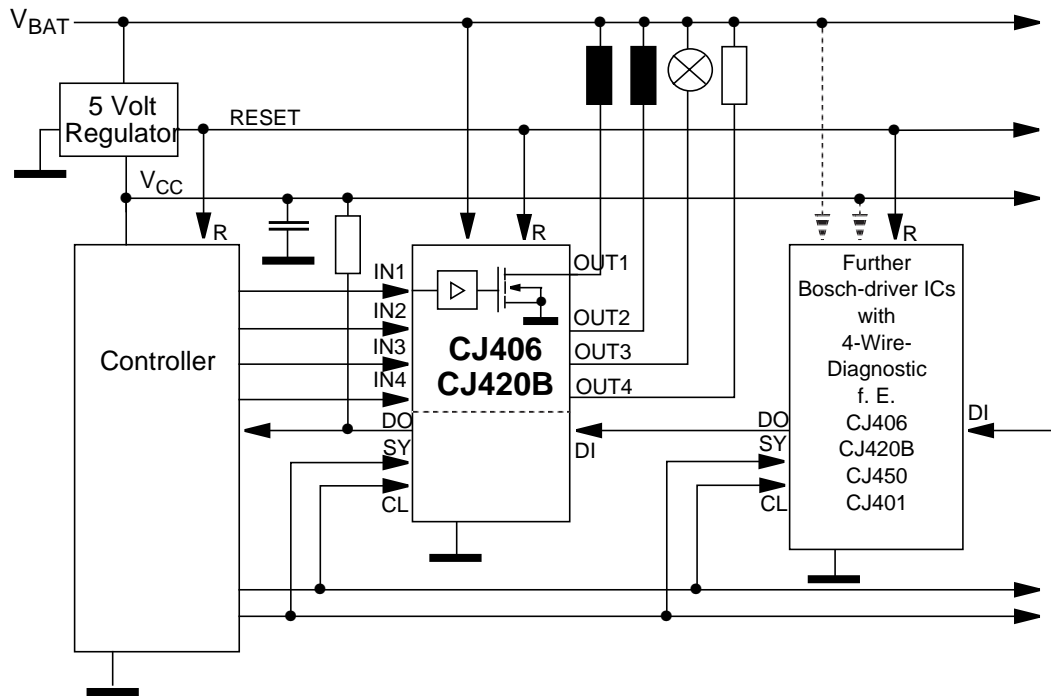

Order No. K8/EIC1-Schm 13.08.97

Page 8 of 8

For further information:

Robert Bosch GmbH
 K8/EIC1 - Schmauder
 Postbox 1342
 72703 Reutlingen
 Tel.: (0 71 21) 35-2152
 Fax: (0 71 21) 35-2880