



Technical Data

CF160

CAN BUS TRANSCEIVER

The CF160 is a bidirectional transceiver for signal conditioning and processing in connection with a CAN controller. Data rates of up to 500 kBaud are supported using either shielded or non-shielded pair of lines.

FEATURES

The CF160 is based on ISO/DIS 11898.

Transmitter

- Generation of differential output signals
- Overtemperature-shutdown
- Slope control to reduce RFI and EMI
- $\overline{\text{RES}}$ -Input to switch off transmitter in case of error

Receiver

- Differential input with high interference suppression
- Common mode input voltage range (V_{COM}) from -5 V to 12 V

Package: SOIC 8

BLOCK DIAGRAM

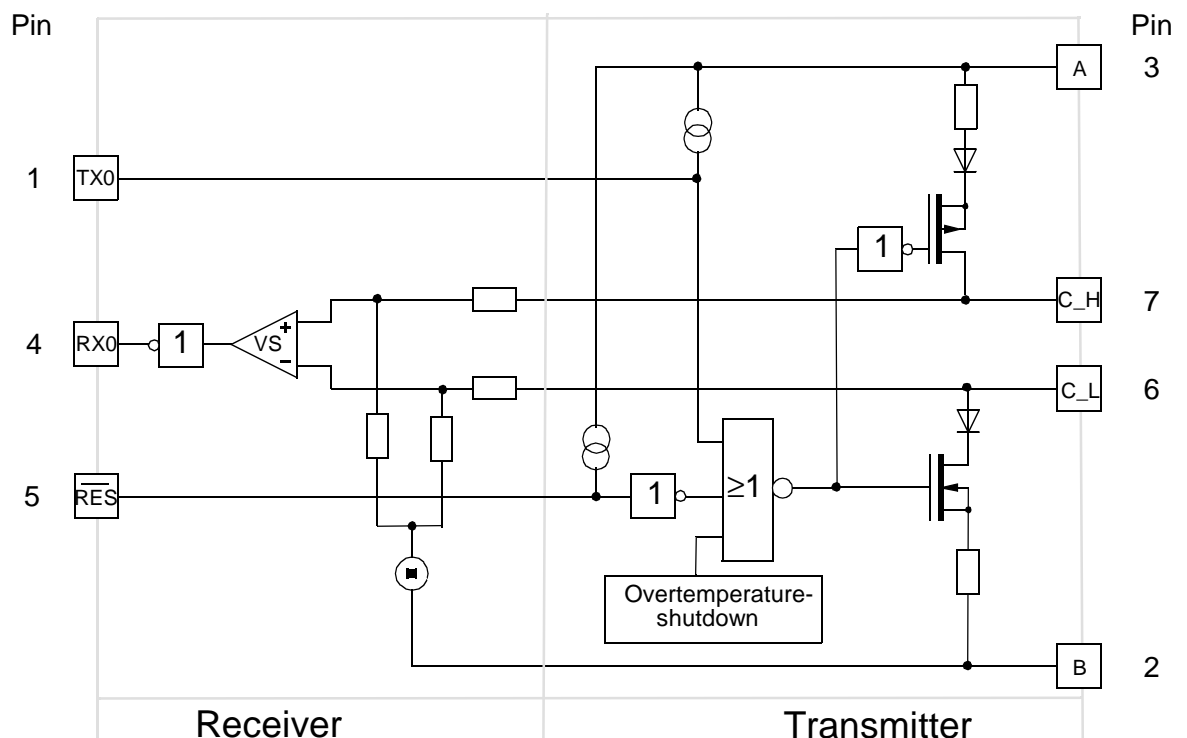

PINNING

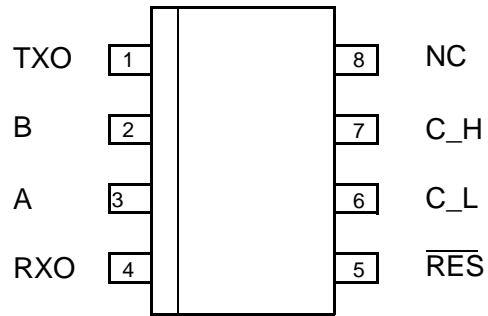

PIN DESCRIPTION

Pin	Name	Description
1	TXO	Transmitter input
2	B	Ground
3	A	Supply voltage
4	RXO	Receive output
5	RES	Reset input (active low)
6	C_L	Low side bus output
7	C_H	High side bus output
8	NC	not connected

MAXIMUM RATINGS

All voltages, except bus voltage, are defined with respect to pin B.
Positive currents flow into the IC.

Rating	Condition	Symbol	Min.	Max.	Unit
Supply voltage (A)		V_A	-0.3	5.5	V
Bus voltage (C_H,C_L)		V_{C_H}, V_{C_L}	-5	36	V
DC voltage at TXO, \overline{RES}		$V_{TXO}, V_{\overline{RES}}$	$V_B-0.3V$	$V_A+0.3V$	
Output current at RXO		I_{RXO}	-0.3	1	mA
Storage temperature		T_{ST}	-40	150	°C
Operating temperature		T_{OP}	-40	125	°C
Junction temperature (normal mode)		T_J	-40	150	°C
Junction temperature (short circuit mode)	for less than a total of 5h over the entire lifetime	T_J		190	°C

CHARACTERISTICS

All voltages, except bus voltage, are defined with respect to pin B.
Positive currents flow into the IC.

General conditions:

$$-40^{\circ}\text{C} < T_{OP} < 125^{\circ}\text{C}$$

$$4.5\text{ V} < V_A < 5.5\text{ V}$$

Comment:

$$\text{Dominant: } V_{TXO} = V_B$$

$$\text{Recessive: } V_{TXO} = V_A$$

Rating	Conditions	Symbol	Min.	Typ.	Max.	Unit
Supply voltage		V_A	4.5	5	5.5	V
Supply current	Dominant, R_A	I_A		50	80	mA
Supply current	Recessive	I_A		6	17	mA

TRANSMITTER SECTION

R_A : 60 Ω between C_H and C_L; $V_{Diff}=V_{C_H}-V_{C_L}$

Rating	Conditions	Symbol	Min.	Typ.	Max.	Unit
TXO Input capacitance	$V_B < V_{TXO} < V_A$	C_{TXO}		5		μF
TXO High level input voltage		V_{TXO}	$0.7V_A$		V_A	
TXO Low level input voltage		V_{TXO}	0		$0.3V_A$	
TXO input current source	$0 < V_{TXO} < 0.7V_A$	$-I_{TXO}$	20	50	170	μA
\overline{RES} High level input voltage		$V_{\overline{RES}}$	$0.7V_A$		V_A	
\overline{RES} Low level input voltage		$V_{\overline{RES}}$	0		$0.25V_A$	
\overline{RES} input current source	$V_B < V_{\overline{RES}} < 0.7V_A$	$-I_{\overline{RES}}$	20	60	170	μA
Bus voltage recessive	Recessive	V_{C_H} V_{C_L}	$0.4V_A$	$0.5V_A$	$0.6V_A$	
Leakage current recessive	$0V < V_{C_L} < 5V$ $0V < V_{C_H} < 5V$	I_{C_H} I_{C_L}	-0.3		0.3	mA
Input resistance	Recessive	$R_{IN(C_H,C_L)}$		20		k Ω
Differential input resistance	Recessive	$R_{Diff(C_H,C_L)}$		40		k Ω
Differential output voltage Dominant	Dominant, R_A $4.75V < V_A < 5.5V$	$V_{Diff=}$ $V_{C_H}-V_{C_L}$	1.5		3	V
Differential output voltage Recessive	Recessive	$V_{Diff=}$ $V_{C_H}-V_{C_L}$	-500	0	50	mV
Supply current in case of short circuit		I_A		140		mA
Thermal resistance		$R_{th_{j-ambient}}$		200		K/W
Overtemperature-shutdown		T_j		180	190	$^{\circ}C$

RECEIVER SECTION

R_A : 60 Ω between C_H and C_L; $V_{Diff}=V_{C_H}-V_{C_L}$

Rating	Conditions	Symbol	Min.	Typ.	Max.	Unit
RXO High level output voltage	$V_{Diff} < 0,4V$ $I_{RXO}=-0.3mA$ $-2V < V_{C_H} < 7V$ $-2V < V_{C_L} < 7V$	V_{RXO}	$0.9V_A$		V_A	V
RXO Low level output voltage	$V_{Diff} > 1V$ $I_{RXO}=1mA$ $-2V < V_{C_H} < 7V$ $-2V < V_{C_L} < 7V$	V_{RXO}			0,5	V
Input signal threshold	$-2V < V_{C_H} < 7V$ $-2V < V_{C_L} < 7V$	V_{Diff}	$0.1V_A$		$0.18V_A$	
Differential input hysteresis	$V_{HYS}=$ $V_{Diff.high} - V_{Diff.low}$	V_{HYS}		200		mV

DYNAMIC CHARACTERISTICS

General conditions:

C_A : 47 pF between C_H and C_L, $V_A=5V$, $t_r < 5ns$

C_{RXO} : 20 pF between RXO and B, R_A : 60 Ω between C_H and C_L

Rating	Conditions	Symbol	Min.	Typ.	Max.	Unit
Signal delay TXO to C_H,C_L		t_T		50		ns
Differential output slew rate		SR		40		V/ μs
Signal delay C_H,C_L to R_XO		t_R			150	ns
Signal delay TXO to RXO		t_{TR}		150	280	ns

FUNCTIONAL DESCRIPTION

The CF160 is used as an interface between a CAN controller and the physical bus. The device provides transmitting capability to the CAN controller.

FUNCTIONAL TABLE

TXO	$\overline{\text{RES}}$	C_H	C_L	Bus State	RXO
L	H or Floating	H	L	Dominant	L
H or Floating	H or Floating	Floating $V_A/2$	Floating $V_A/2$	Recessive	H
L	L	Floating $V_A/2$	Floating $V_A/2$	Recessive	H
H or Floating	L	Floating $V_A/2$	Floating $V_A/2$	Recessive	H

APPLICATION NOTE

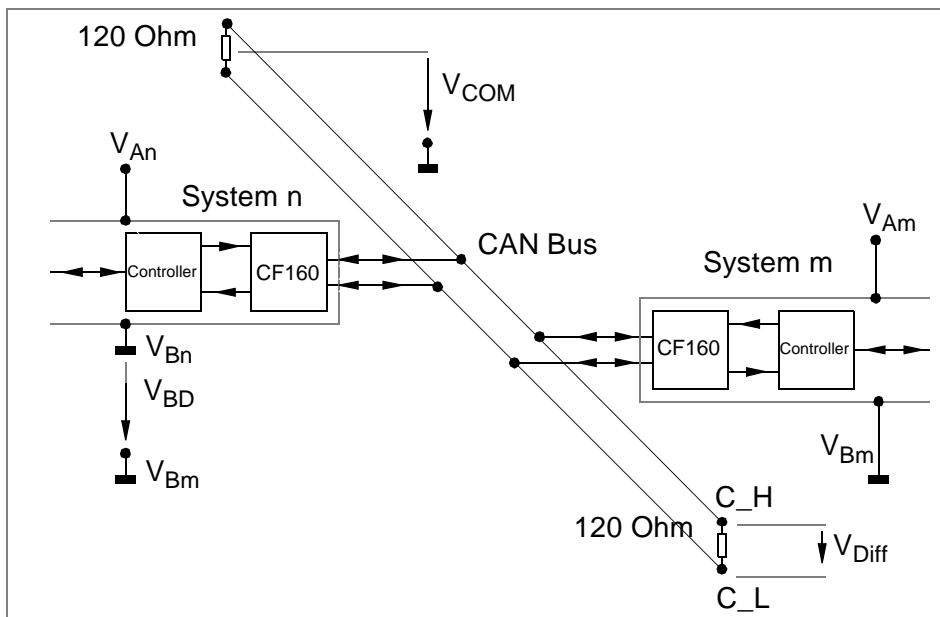

TIMING DIAGRAM

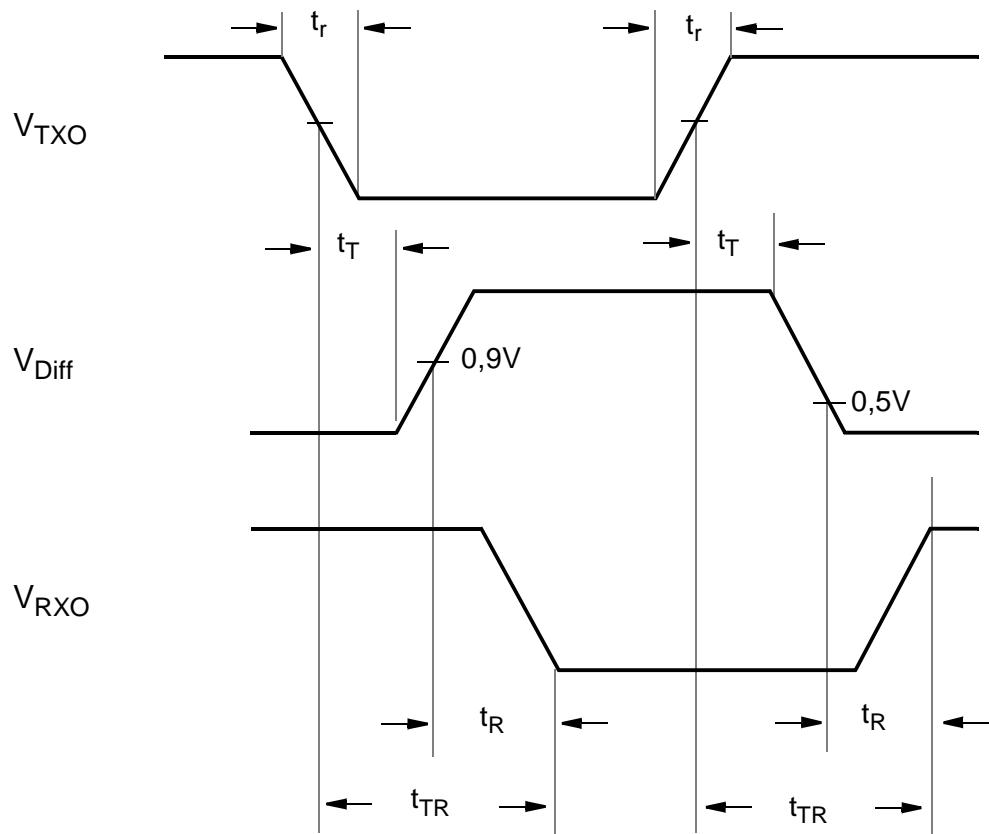

Package: SOIC 8 - Narrow

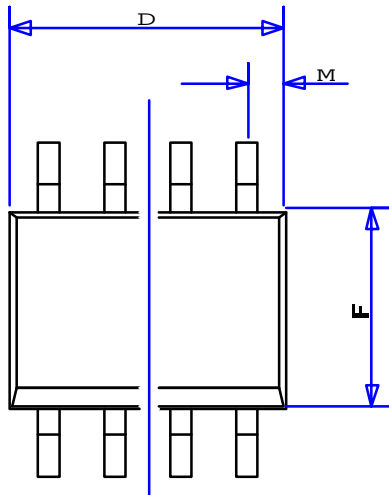
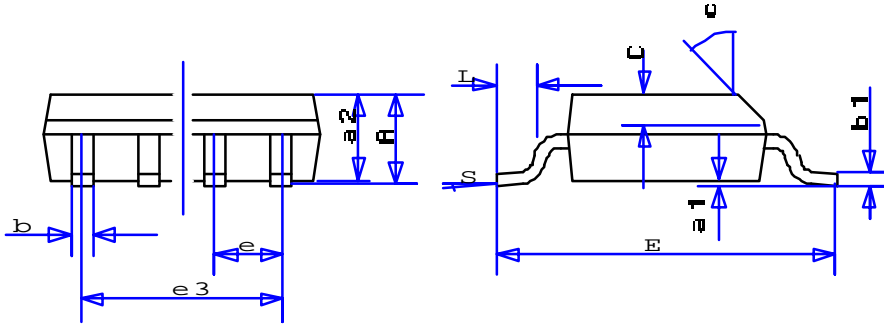

Ref.	Data Book	mm	
	Typ	Min	Max
A			1.75
a1		0.10	0.25
a2			1.65
b		0.35	0.48
b1		0.19	0.25
C	0.50		
c1	45°		
D	see variations		
E		5.8	6.2
e	1.27		
e3	see variations		
F		3.8	4.0
L		0.4	1.27
M			0.6
S			8 ⁰

Variations D/ mm			
N	Typ	Min	Max
8		4.8	5.0

Variations e3/mm			
N	Typ	Min	Max
8		3.81	

In the interest of product improvement, Bosch reserves the right to change specifications without notice

For further information:

Robert Bosch K.K.
Bosch Technical Center
9-1, Ushikubo 3-chome
Tsuzuki-ku, Yokohama 224
Tel.: 045 (912) 8301
Fax: 045 (912) 9573

Robert Bosch Corporation
Automotive Group (UO/SAM2)
38000 Hills Tech Drive
Farmington Hills, MI 48331-3417
Tel.: (248) 553-1390
Fax: (248) 553-7926

Robert Bosch GmbH
Abteilung K8/VKF
Postfach 1342
72703 Reutlingen
Tel.: (07121) 35-2979
Fax: (07121) 35-2170