

ITEM	QTY	PART NUMBER	PART DESCRIPTION
1	1	H-485C	Quad-Level Sub-Miniature (1.8mm) LED 90° Holder
2	3	1.8RD	Small Footprint, Radial Lead Orientation (1.8mm)
3	1	1.8GD	Small Footprint, Radial Lead Orientation (1.8mm)

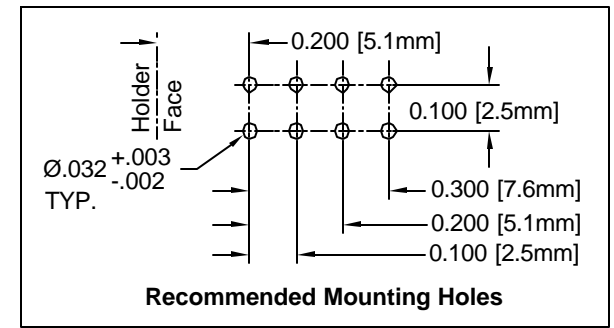

REV.	DESCRIPTION	DATE	APPROVED
A	Engineering Release.	06/01/06	M. C.

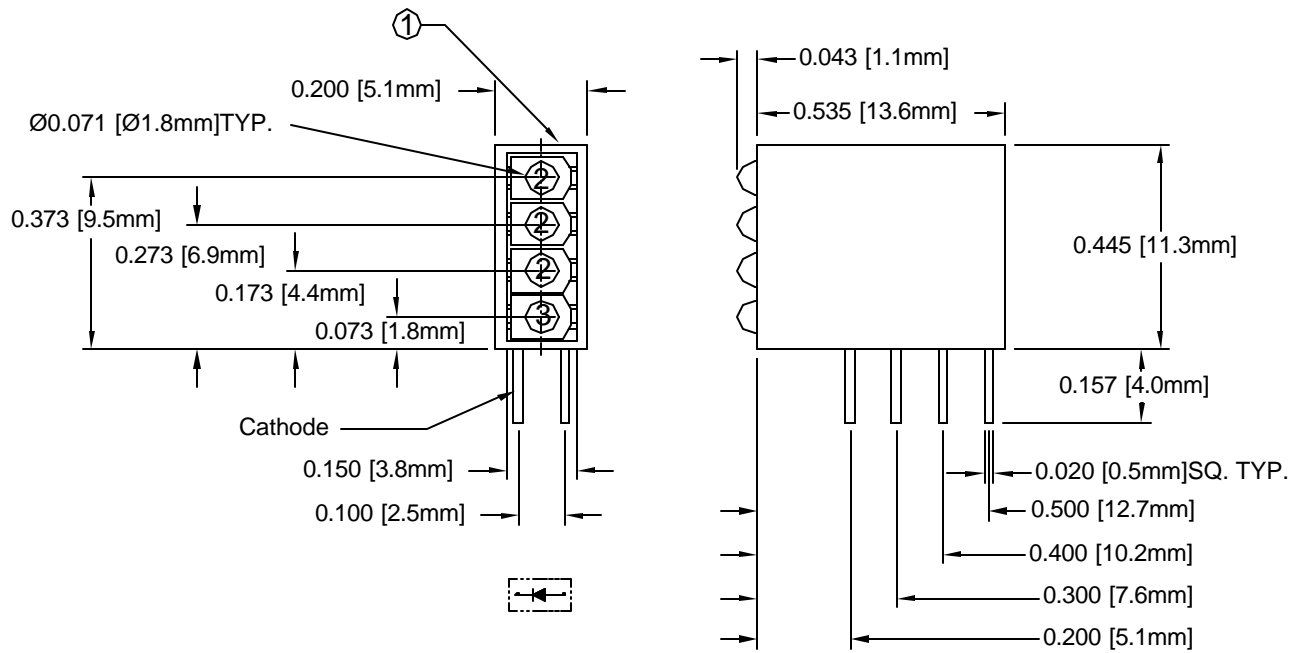

LED Part No.	Chip			Lens Appearance	Absolute Maximum Ratings				Electro-Optical Data @ 20mA			Viewing Angle (Deg)
	Material	Peak Wave Length λ_p (nm)	Emitted Color		$\Delta\lambda$ (nm)	Pd (mW)	If (mA)	Peak If (mA)	Vf (V)		Iv (mcd)	
									Typ.	Max.	Typ.	
1.8RD	GaAsP/GaAs	655	RED	DIFFUSED	100	40	15	150	2.3	2.6	1.0	70
1.8GD	GaP/GaP	565	GREEN	DIFFUSED	30	80	30	150	2.2	2.6	5.0	70

ABSOLUTE MAXIMUM RATINGS (Ta = 25°C)

REVERSE VOLTAGE _____ 5V
 REVERSE CURRENT (VR=5V) _____ 100µA
 OPERATING TEMPERATURE RANGE _____ -25°C ~ 85°C
 STORAGE TEMPERATURE _____ -30°C ~ 100°C
 LEAD SOLDERING TEMPERATURE (1/16" FROM BODY) _____ 260°C for 5 Seconds

STANDARD TOLERANCE (UNLESS OTHERWISE SPECIFIED)		 4 THOMAS, IRVINE, CA. 92618 TEL: (949) 951-8808 FAX: (949) 951-3974
DECIMALS	ANGULAR	
.X ±.1	X° ± 1°	
.XX ±.02		 TITLE: Sub-Miniature (1.8mm) RP 90° Quad-Level LED Assembly
.XXX ±.010		
DESIGNED: Sonny Dam	DATE: 01/26/07	PART NO: H485CRRRGD-RP
CHECKED: D. Beckman	DATE: 01/26/07	REVISION: A
CAGE CODE : 32559		SHEET # 1 OF 1
CAD GENERATED DOCUMENT. DO NOT MEASURE DRAWING.		