

# APT-CC-VX-SQ MODULES



## Features

- > APT-CC controllers add advanced control features to constant current (CC) drivers
- > Integrated between the CC driver and LED modules, the DC modules are powered directly from the CC driver
- > Controlling 2 output channels, Correlated Color Temperature (CCT) can be calibrated precisely, independent of intensity
- > APT Programmer enables in-factory and in-field changes to control settings including CCT range and CCT mapping
- > Wired versions available with DMX512/RDM (VA) or isolated 0-10V ports (VC)
- > Wireless versions available (VWx) with Casambi BLE Mesh or Silvair BLE Mesh
- > Wireless controller versions available with either embedded antenna (EA) or whip antenna (WA)

## Ordering Information

Product Code	Description
<b>APT-CC-Vx-SQ-wwwww</b>	<b>Vx</b> – Hardware version <b>SQ</b> – Square form factor <b>wwwww</b> – Internal code provided by Arkalumen as a simplified configuration code for repeat orders
Hardware Version	Functionality
VA	DMX512/RDM
VC	0-10V
VWx	Wireless – BLE Mesh

## System Architecture

Design Requirements
1. Color mixing of light is produced by adjusting the intensity ratio between two LED channels. Therefore, the maximum current should be determined by the LED channel with the lower maximum current of the two.
2. Intensity control in APT-CC controllers requires the use of constant current drivers equipped with an isolated 0-10V dimming port. This requirement applies to the DMX/RDM (VA) and wireless (VWx) versions.
3. APT controllers are designed to work with a wide range of drivers, but a fixture manufacturer must test the APT controller for driver compatibility and ensure proper system operation before installation.
4. Contact Arkalumen for information on compatibility of drivers and overall system architectures. The light fixture manufacturer is responsible for testing of all third party components and the overall system before installation.

Contact Arkalumen for technical support at [support@arkalumen.com](mailto:support@arkalumen.com)

## Operating Conditions

Environmental	
Ambient Temperature, Range	-40 to +50°C
Case Material	Plastic

Arkalumen Products may be covered by patents in the US and elsewhere.

[www.arkalumen.com/patents](http://www.arkalumen.com/patents)

## Mechanical Specifications

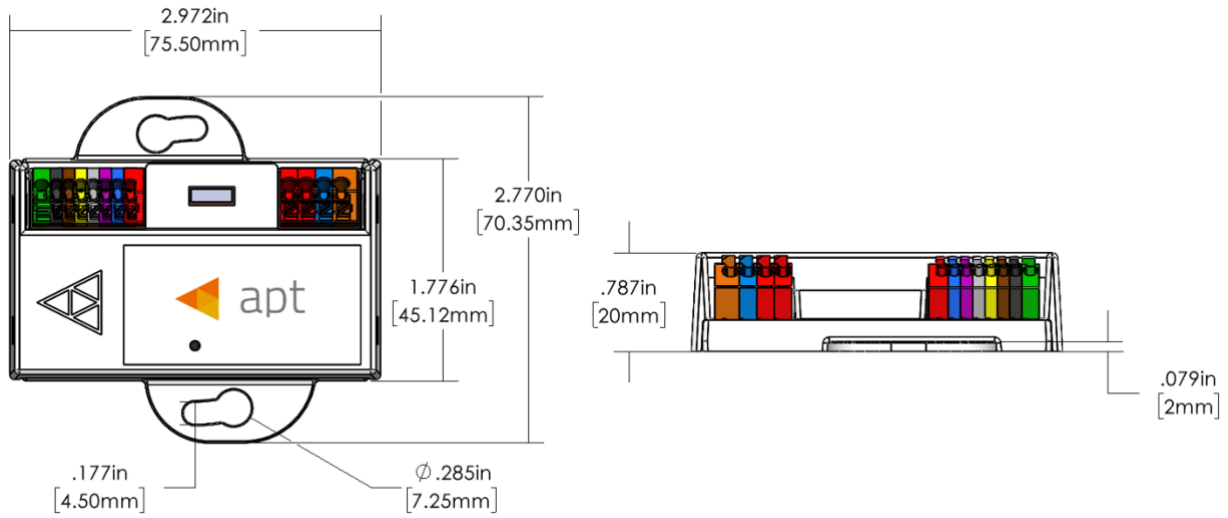

Figure 1 – APT-CC-Vx Mechanical Drawing

Dimensions	Inches
Length	6.20
Width	1.18
Height	0.78

# APT-CC-VA-SQ MODULE (DMX512/RDM)

## Electrical Specifications

### Input

Port	Voltage		Unit	Current		Unit	Power		
	Min	Max		Min	Max		Min	Max	
DC IN +/-	10	60	V	60	4,100	mA	-	100	W
0-10V OUT +/-	0	12	V	0	90	μA	-	-	
DMX DATA +/-	-10	15	V	-0.8	1	mA	-	-	

### Output

Port	Voltage		Unit	Current		Unit	Power		
	Min	Max		Min	Max		Min	Max	
CH1	-	60	V	0	4,040	mA	-	100	W
CH2	-	60	V	0	4,040	mA	-	100	W

### Wiring Diagram

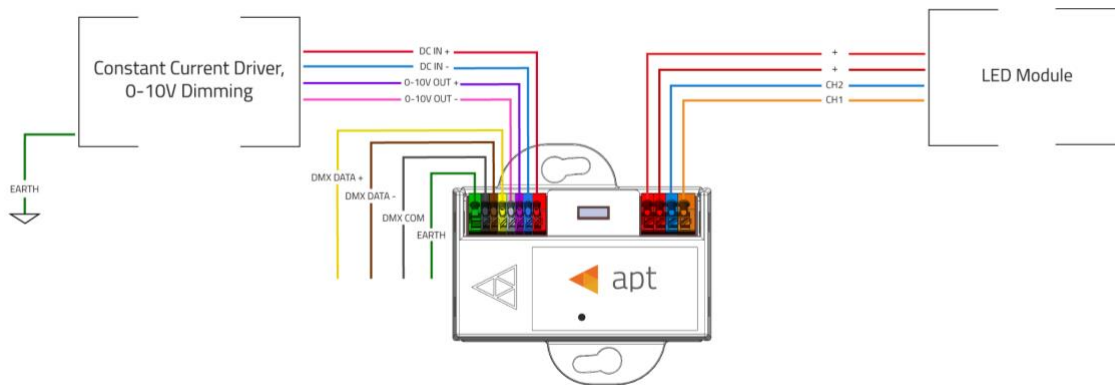

Figure 2 – APT-CC-VA-SQ DMX Configuration

Wiring	AWG
Input	20-26
Output, Earth	16-22



7.5-8.5mm wire preparation

## Ordering Information

Product Code	Description
<b>APT-CC-VA-SQ-<i>www</i></b>	<b>VA</b> – DMX/RDM hardware version <b>SQ</b> – Square form factor <b><i>www</i></b> – Internal code provided by Arkalumen as a simplified configuration code for repeat orders

Configuration Code	Description
<b><i>DMXn-Ammm-pppp-Hxxx-Lyyy</i></b>	<b><i>DMXn</i></b> – Number of DMX addresses assigned <b><i>Ammm</i></b> – Base DMX address <b><i>pppp</i></b> – Output control feature <b><i>Hxxx</i></b> – Max current threshold <b><i>Lyyy</i></b> – Min current threshold

## Configuration Code Details

Code	Description	Option	Configuration Trait
<b><i>DMXn</i></b>	<b><i>DMXn</i></b> denotes DMX wired communication using <i>n</i> addresses.	<b>DMX1</b>	DMX wired communication using 1 DMX address
		<b>DMX2</b>	DMX wired communication using 2 DMX addresses
<b><i>Ammm</i></b>	<b><i>mmm</i></b> denotes the base address of the controller on a DMX bus.	<b>A001</b>	Lowest base address option
		<b>A###</b>	Base address specified between 1 and 512
		<b>A512</b>	Highest base address option
<b><i>pppp</i></b>	<b><i>pppp</i></b> denotes the output control features enabled on the controller.	<b>IN00</b>	Intensity control enabled, CCT control disabled
		<b>00CT</b>	Intensity control disabled, CCT control enabled
		<b>INCT</b>	Intensity and CCT control enabled
<b><i>Hxxx</i></b>	<b><i>xxx</i></b> denotes the maximum current as configured in the controller's firmware in 20mA increments.	<b>0000</b>	Intensity control disabled
		<b>H###</b>	Maximum current specified up to 4,100mA
		<b>H410</b>	Maximum current of 4,100mA (Default)
<b><i>Lyyy</i></b>	<b><i>yyy</i></b> denotes the minimum current as configured in the controller's firmware in 20mA increments.	<b>0000</b>	Intensity control disabled
		<b>L###</b>	Minimum current specified as low as 20mA
		<b>L006</b>	Minimum current of 60mA (Default)

# APT-CC-VC-SQ MODULE (0-10V)

## Electrical Specifications

### Input

Port	Voltage		Current			Power	
	Min	Max	Min	Max	Unit	Min	Max
DC IN +/-	10	60 V	40	4,100	mA	-	100 W
0-10V IN (Sink)	0	20 V	98	104	μA	-	-
0-10V IN (Source)	0	20 V	0	300	μA	-	-

### Output

Port	Voltage		Current			Power	
	Min	Max	Min	Max	Unit	Min	Max
CH1	-	60 V	0	4,060	mA	-	100 W
CH2	-	60 V	0	4,060	mA	-	100 W

## Wiring Diagram

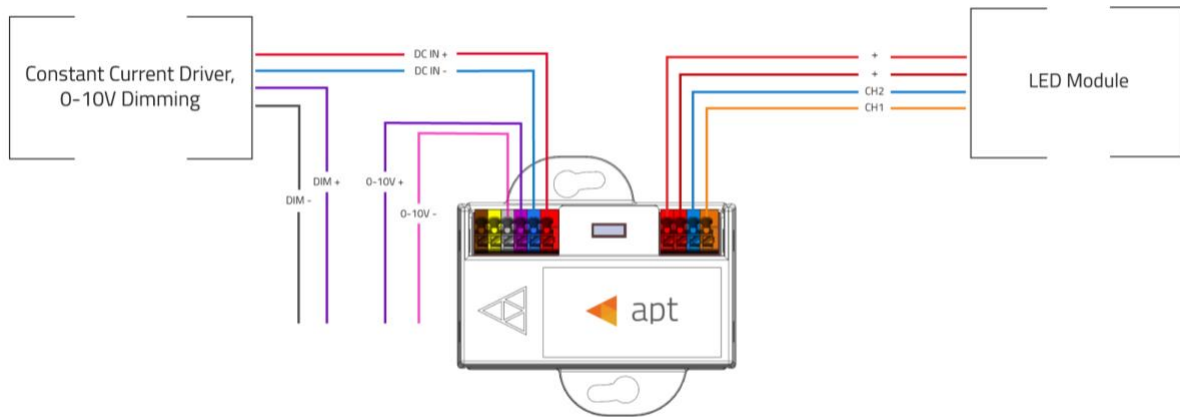

Figure 3 - APT-CC-VC-SQ 0-10V Configuration

Wiring	AWG
Input, Output	16-22

INPUT, OUTPUT



7.5-8.5mm wire preparation

## Ordering Information

Product Code	Description
<b>APT-CC-VC-SQ-<i>wwwww</i></b>	<b>VC</b> – 0-10V hardware version <b>SQ</b> – Square form factor <b><i>wwwww</i></b> – Internal code provided by Arkalumen as a simplified configuration code for repeat orders

Configuration Code	Description
<b>CCTD-0000-00CT-0000-0000</b>	<b>CCTD</b> – CCT control using a 0-10V dimmer <b>0000</b> – Reserved <b>00CT</b> – CCT control enabled <b>0000</b> – Reserved <b>0000</b> – Reserved

The APT-CC-VC-SQ configuration code is static.

# APT-CC-VWx-SQ MODULE (WIRELESS)

## Electrical Specifications

### Input

Port	Voltage		Unit	Current		Unit	Power	
	Min	Max		Min	Max		Min	Max
DC IN +/-	24	60	V	12	4,100	mA	-	100
0-10V OUT +/-	0	12	V	0	90	μA	-	-

### Output

Port	Voltage		Unit	Current		Unit	Power	
	Min	Max		Min	Max		Min	Max
CH1	24	60	V	0	4,088	mA	-	100
CH2	24	60	V	0	4,088	mA	-	100

Wireless Operating Conditions <sup>1</sup>	
Maximum Transmitter Power	+4dBm
Operating Frequencies	2.4GHz
Maximum Open-Air Range	270m

Contains modular transmitter with FCC ID: X8WBM832, IC (Industrial Canada) ID: 4100A-BM832

Wireless signal range of the controller will decrease if placed in a metal enclosure or placed near other wireless devices operating at similar frequencies, keep the VWx controller at least 20cm away from other VWx controllers or wireless devices. The end product with this module may subject to perform FCC part 15 unintentional emission test requirement and be properly authorized.

This device is intended for OEM integrator only.

If used with ANT020 antenna or integrated PCB trace antenna, device does not require routine evaluation or SAR testing.

### Wiring Diagram

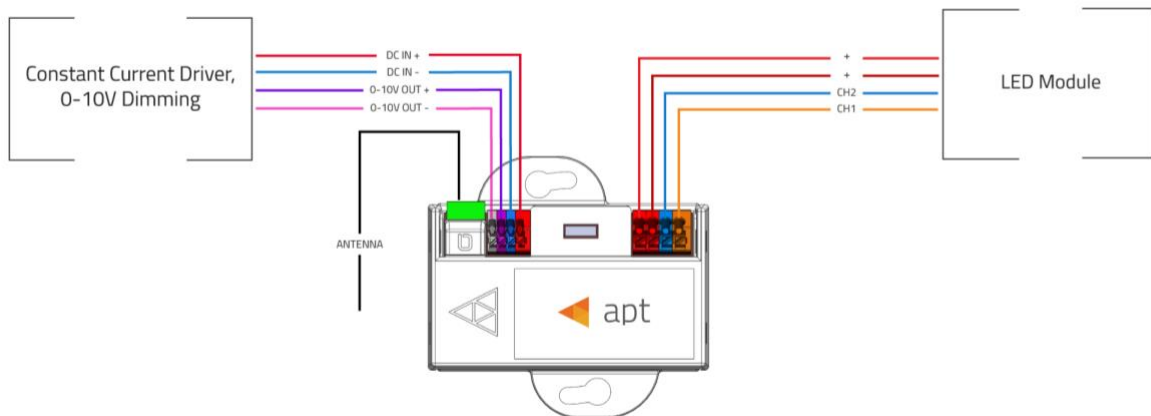
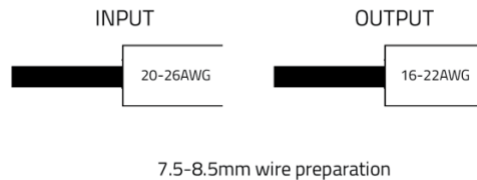

Figure 3 - APT-CC-VWx-SQ Wireless Communication Configuration

Wiring	AWG
Input	20-26
Output	16-22
Antenna	ANT020*

\*Integrated embedded PCB trace antenna option available on request, ANT020 antenna does not come with device by default, please include request for antenna if necessary



### Ordering Information

Product Code	Description
<b>APT-CC-VWx-SQ-yA-wwww</b>	<b>VWx</b> – Wireless - BLE Mesh hardware version (VWC – Casambi BLE, VWS – Silvair BLE) <b>SQ</b> – Square form factor <b>yA</b> – Antenna version (EA – embedded antenna, WA -whip antenna) <b>wwww</b> – Internal code provided by Arkalumen as a simplified configuration code for repeat orders

Configuration Code	Description
<b>nnn-0000-pppp-Hxxx-Lyyy</b>	<b>nnn</b> – Wireless communication source <b>0000</b> – Reserved <b>pppp</b> – Output control feature <b>Hxxx</b> – Max current threshold <b>Lyyy</b> – Min current threshold

### Configuration Code Details

Code	Description	Option	Configuration Trait
<b>nnn</b>	<b>nnn</b> denotes the wireless communication source implemented.	<b>CBM</b>	Wireless via Casambi BLE Mesh
		<b>SBM</b>	Wireless via Silvair BLE Mesh
<b>pppp</b>	<b>pppp</b> denotes the output control features enabled on the controller.	<b>IN00</b>	Intensity control enabled, CCT control disabled
		<b>00CT</b>	Intensity control disabled, CCT control enabled
		<b>INCT</b>	Intensity and CCT control enabled
<b>Hxxx</b>	<b>xxx</b> denotes the maximum current as configured in the controller’s firmware in 20mA increments.	<b>0000</b>	Intensity control disabled
		<b>H###</b>	Maximum current specified up to 4,100mA
		<b>H410</b>	Maximum current of 4,100mA (Default)
<b>Lyyy</b>	<b>yyy</b> denotes the minimum current as configured in the controller’s firmware in 20mA increments.	<b>0000</b>	Intensity control disabled
		<b>L###</b>	Minimum current specified as low as 20mA
		<b>L006</b>	Minimum current of 60mA (Default)