

MGA-16516

Low Noise, High Linearity Match Pair Low Noise Amplifier



Data Sheet

Description

Avago Technologies' MGA-16516 is an economical, easy-to-use GaAs MMIC match pair Low Noise Amplifier (LNA). The LNA has low noise and high linearity achieved through the use of Avago Technologies' proprietary 0.25um GaAs Enhancement-mode pHEMT process. It is housed in a miniature 4.0 x 4.0 x 0.85mm³ 16-pin Quad-Flat-Non-Lead (QFN) package. The compact footprint and low profile coupled with low noise, high gain and high linearity make the MGA-16516 an ideal choice as a low noise amplifier for cellular infrastructure for GSM and CDMA. This device is applicable to both Single and Balance mode. It is designed for optimum use from 500MHz to 1.7GHz. For optimum performance at higher frequency from 1.7GHz to 2.7GHz, the MGA-17516 is recommended. Both MGA-16516 and MGA-17516 share the same package and pinout.

Package Marking

4.0 x 4.0 x 0.85 mm³ 16-lead QFN



Top View

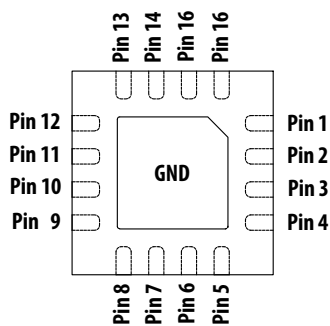

Bottom View

Note:

Package marking provides orientation and identification

"16516" = Device Code

"YYWW" = Year and Work Week

"XXXX" = Last 4 digit of Device Lot Number

Features

- Low noise figure
- High linearity performance
- GaAs E-pHEMT Technology^[1]
- Low cost small package size: 4.0x4.0x0.85 mm³
- Excellent uniformity in product specifications
- Tape-and-Reel packaging option available

Specifications

850MHz; 5V, 50mA (typ) per section

- 17.7 dB Gain
- 0.4 dB Noise Figure
- 11.8 dBm Input IP3
- 18.3 dBm Output Power at 1dB gain compression

Applications

- Low noise amplifier for cellular infrastructure for GSM and CDMA.
- Other ultra low noise application.



Attention: Observe precautions for handling electrostatic sensitive devices.

ESD Machine Model = 60V

ESD Human Body Model = 350V

Refer to Avago Application Note A004R:

Electrostatic Discharge, Damage and Control.

Pin Configuration

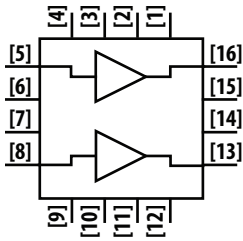

Pin	Use
1	Not Used
2	Not Used
3	Not Used
4	Not Used
5	RFin1
6	Not Used
7	Not Used
8	RFin2
9	Not Used
10	Not Used
11	Not Used
12	Not Used
13	RFout2
14	Not Used
15	Not Used
16	RFout1

Simplified Schematic

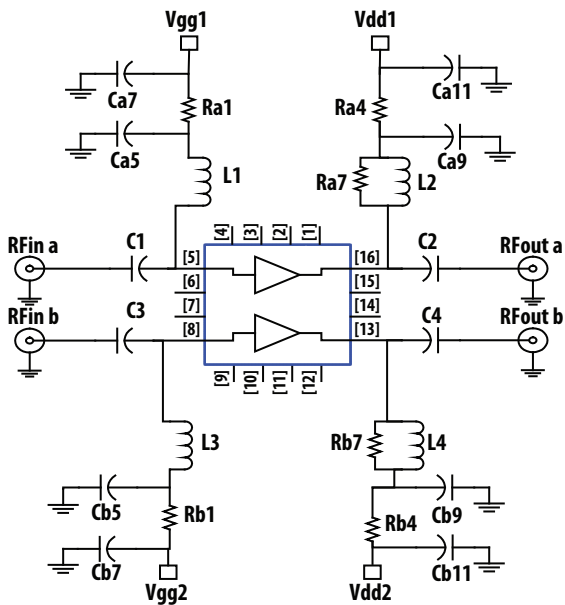

Note:

- Enhancement mode technology employs positive gate voltage, thereby eliminating the need of negative gate voltage associated with conventional depletion mode devices.

Absolute Maximum Rating ^[2] T_A = 25°C

Symbol	Parameter	Units	Absolute Max.
V _{dd}	Device Voltage, RF output to ground	V	5.5
V _{gg}	Gate Voltage	V	1
P _{in,max}	CW RF Input Power (V _{dd} = 5.0, I _{dd} = 50mA)	dBm	15
I _{dd}	Device Current, RFout to ground per channel	mA	100
P _{diss}	Total Power Dissipation ^[4]	W	1
T _j	Junction Temperature	°C	150
T _{STG}	Storage Temperature	°C	-65 to 150

Thermal Resistance ^[3]

(V_{dd} = 5.0V, I_{dd} = 50mA per channel),
θ_{jc} = 49.4°C/W per channel

Notes:

- Operation of this device in excess of any of these limits may cause permanent damage.
- Thermal resistance measured using Infra-Red Measurement Technique with both channels turned on hence I_{dd,total} = 100mA.
- Power dissipation with both channels turned on. Board temperature T_B is 25°C. Derate at 20mW/°C for T_B > 100°C.

Electrical Specifications ^[7-10]

RF performance at T_A = 25°C, V_{dd} 5V, I_{dd} = 50mA, 850MHz and 900MHz given for each RF channel, measured on demo board in Figure 5 with component list in Table1 for 850 MHz matching.

Symbol	Parameter and Test Condition	Frequency	Units	Min.	Typ.	Max.
V _{gg}	Operational Gate Voltage, I _{dd} = 50mA		V	0.38	0.48	0.63
Gain	Gain	850	dB		17.7	
		900	dB	15.8	17.4	18.8
IIP3 ^[8]	Output Third Order Intercept Point	850	dBm		11.8	
		900	dBm	10.5	12.4	
NF ^[9]	Noise Figure	850	dB		0.40	
		900	dB		0.41	0.70
OP1dB	Output Power at 1dB Gain Compression	850	dBm		18.3	
		900	dBm		19.3	
IRL	Input Return Loss, 50Ω source	850	dB		8.9	
		900	dB		7.0	
ORL	Output Return Loss, 50Ω load	850	dB		3.3	
		900	dB		4.7	
REV ISOL	Reverse Isolation	850	dB		29.9	
		900	dB		29.5	
ISOL ₁₋₂	Isolation between RFin1 and RFin2	850	dB		45	
		900	dB		45	

Notes:

7. Measurements at 850 MHz and 900 MHz are obtained using demo board described in Figure 5.

8. IIP3 test condition:

- F_{RF1} = 850 MHz, F_{RF2} = 851 MHz with input power of -15dBm per tone.
- F_{RF1} = 900 MHz, F_{RF2} = 901MHz with input power of -15dBm per tone.

9. For NF data, board losses of the input have not been de-embedded.

10. Use proper bias, heatsink and derating to ensure maximum channel temperature is not exceeded. See absolute maximum ratings and application note for more details.

Product Consistency Distribution Charts

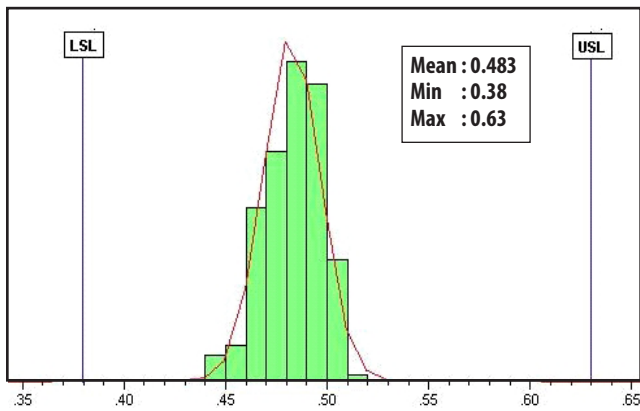

Figure 1. Vgg @ 900MHz, 5V, 50mA
Mean = 0.48

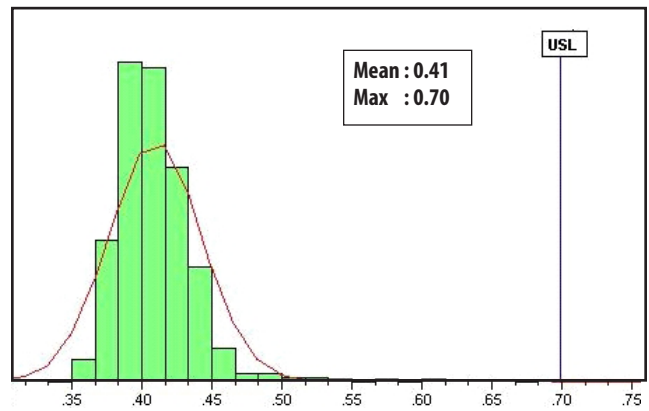

Figure 2. Noise Figure @ 900MHz, 5V, 50mA
Mean = 0.41

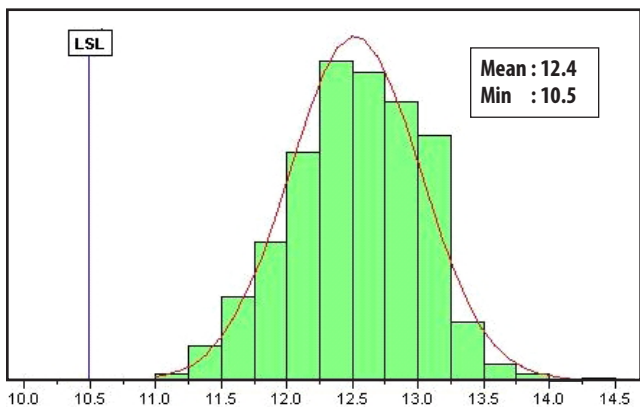

Figure 3. IIP3 @ 900MHz, 5V, 50mA
Mean = 12.4

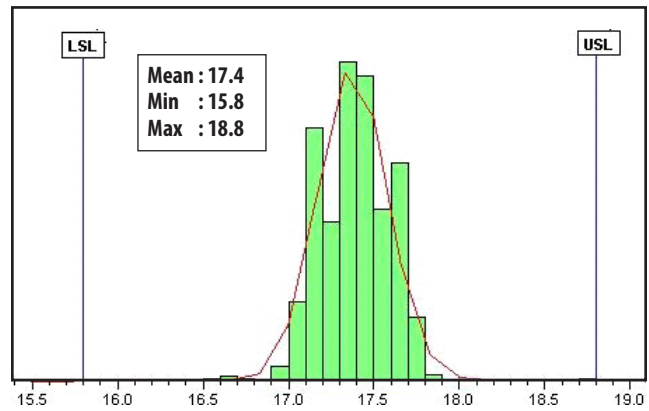

Figure 4. Gain @ 900MHz, 5V, 50mA
Mean = 17.4

Notes:

1. Distribution data samples size is 500 samples taken from 4 different wafers. Future wafers allocated to this product may have nominal values anywhere between the upper and lower limits. Circuit losses have not been de-embedded from actual measurement.

Demo Board Layout

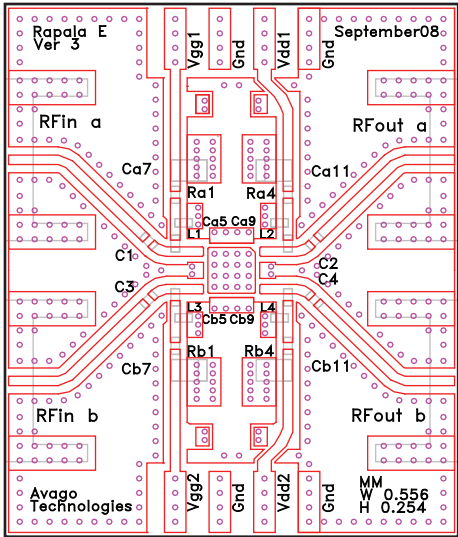

Figure 5. Demo Board Layout Diagram

- Recommended PCB material is 10 mils Rogers RO4350 with a total thickness 62 mils
- Suggested component values may vary according to layout and PCB material.

Demo Board Schematic

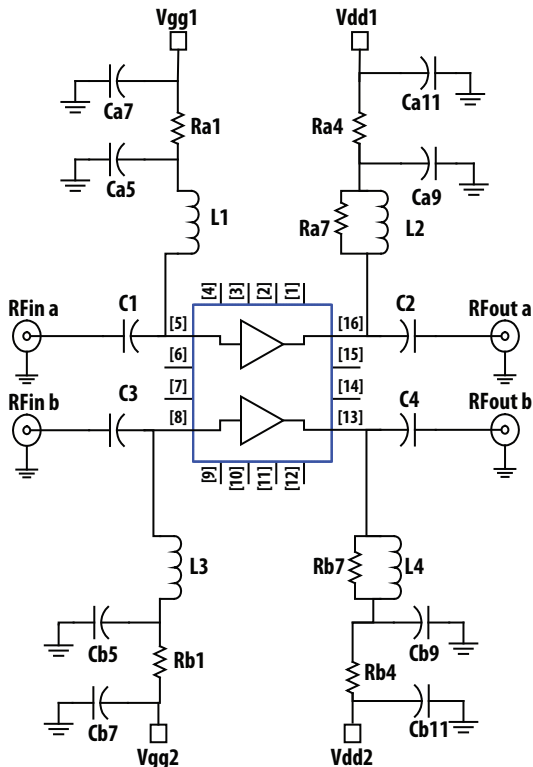

Figure 6. Demo Board Schematic Diagram

Table 1. Component list for 850 MHz matching.

Part	Size	Value	Detail Part Number
C1, C3	0402	15pF(Murata)	GJM1555C1H150JB01D
C2, C4	0402	3.3pF(Murata)	GJM1555C1H3R3CB01D
L1, L3	0402	30nH(Coilcraft)	0402CS-30NXJLU
L2, L4	0402	22nH(Toko)	LL1005-FHL22NJ
Ra7, Rb7	0402	110Ohm(ROhm)	MCR01MZCJ111
Ca5, Cb5	0402	12pF(Murata)	GJM1555C1H120JB01D
Ca9, Cb9	0402	6pF(Murata)	GJM1555C1H6R0CB01D
Ra1, Rb1	0402	56Ohm(ROhm)	MCR01MZSJ560
Ra4, Rb4	0402	9.1Ohm(Rohm)	MCR01MZSJ9R1
Ca7, Cb7	0805	4.7uF(Murata)	GRM21BR60J475KA11L
Ca11, Cb11	0805	4.7uF(Murata)	GRM21BR60J475KA11L

MGA-16516 Typical Performance

RF performance for each RF channel at $T_A = 25^\circ\text{C}$, $V_{dd} = 5\text{V}$, $I_{dd} = 50\text{mA}$ unless otherwise stated. OIP3 is measured with input power of -15dBm per tone.

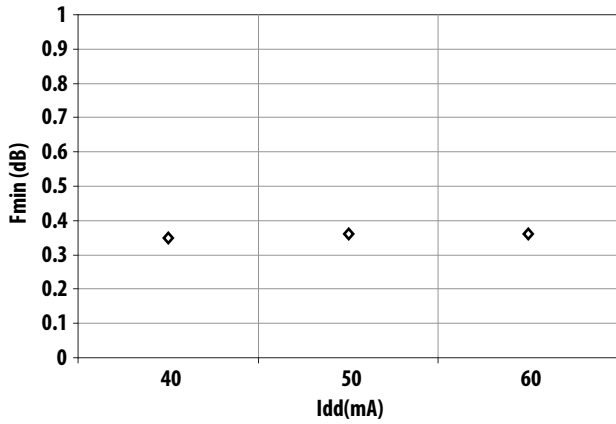

Figure 7. Fmin vs Idd at 5V at 700MHz

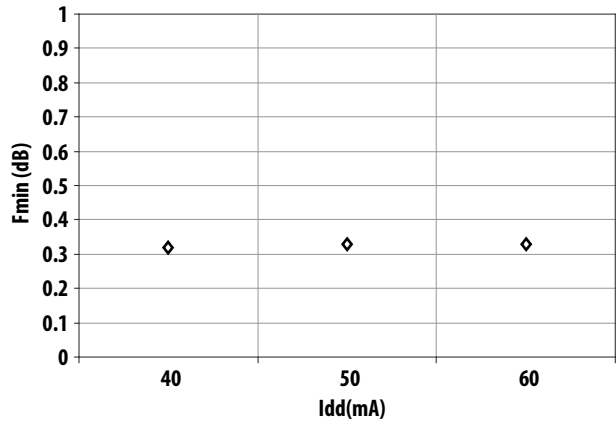

Figure 8. Fmin vs Idd at 5V at 900MHz

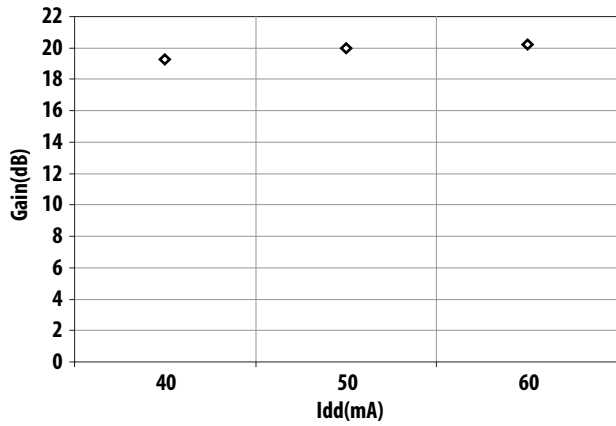

Figure 9. Gain vs Idd at 5V Tuned for Optimum OIP3 and Fmin at 700MHz

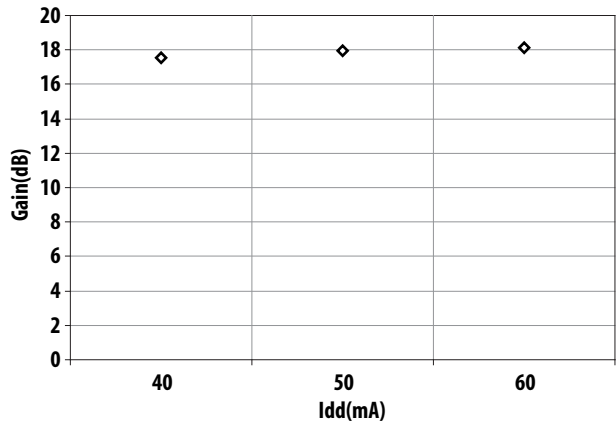

Figure 10. Gain vs Idd at 5V Tuned for Optimum OIP3 and Fmin at 900MHz

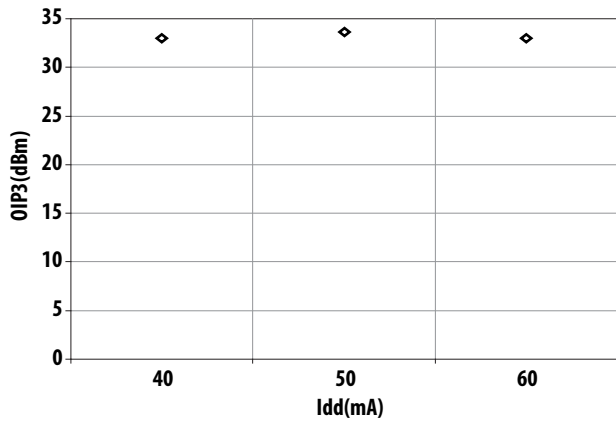

Figure 11. OIP3 vs Idd at 5V Tuned for Optimum OIP3 and Fmin at 700MHz

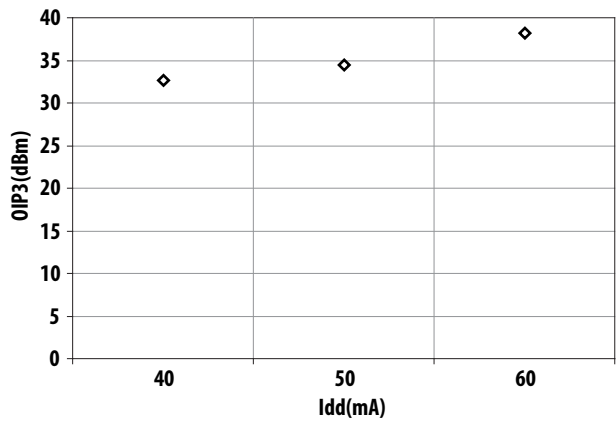

Figure 12. OIP3 vs Idd at 5V Tuned for Optimum OIP3 and Fmin at 900MHz

MGA-16516 Typical Performance

RF performance for each RF channel at $T_A = 25^\circ\text{C}$, $V_{dd} = 5\text{V}$, $I_{dd} = 50\text{mA}$ unless otherwise stated. OIP3 is measured with input power of -15dBm per tone.

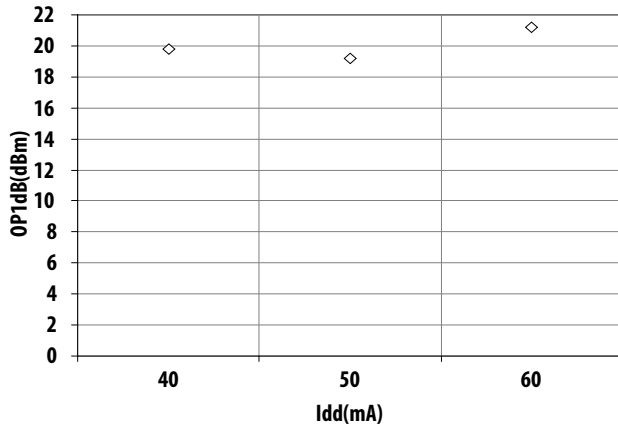

Figure 13. OP1dB vs I_{dd} at 5V Tuned for Optimum OIP3 and Fmin at 700MHz

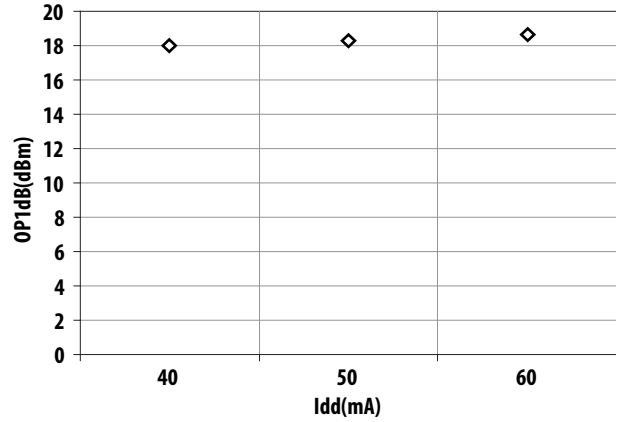

Figure 14. OP1dB vs I_{dd} at 5V Tuned for Optimum OIP3 and Fmin at 900MHz

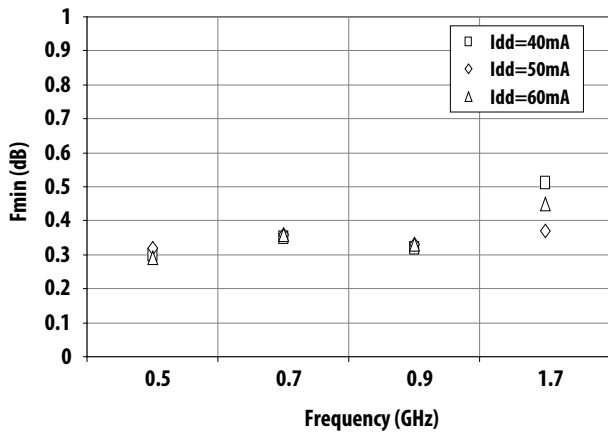

Figure 15. Fmin vs Frequency and I_{dd} at 5V

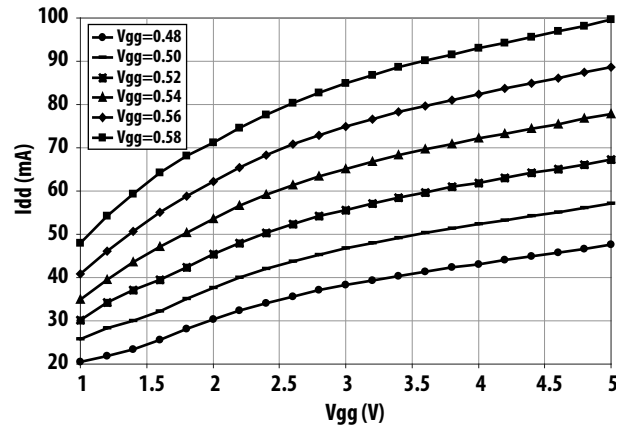

Figure 16. I-V curve

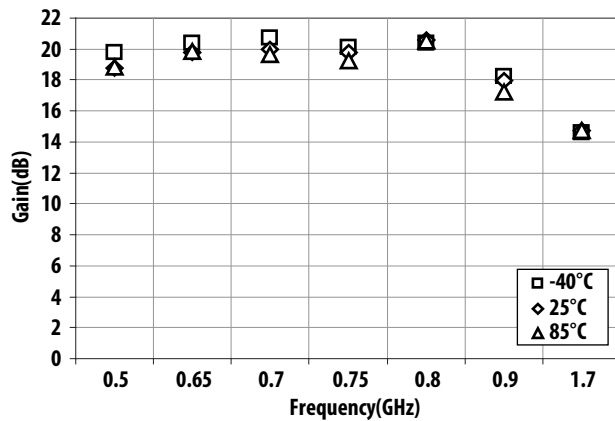

Figure 17. Gain vs Frequency and Temperature tuned for Optimum OIP3 and Fmin at 5V 50mA

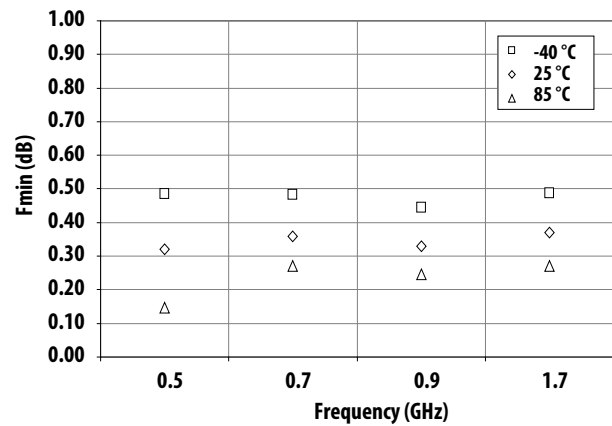

Figure 18. Fmin vs Frequency and Temperature tuned for Optimum OIP3 and Fmin at 5V 50mA

MGA-16516 Typical Performance

RF performance at $T_A = 25^\circ\text{C}$, $V_{dd} = 5\text{V}$, $I_{dd} = 50\text{mA}$ unless otherwise stated. OIP3 is measured with input power of -15dBm per tone.

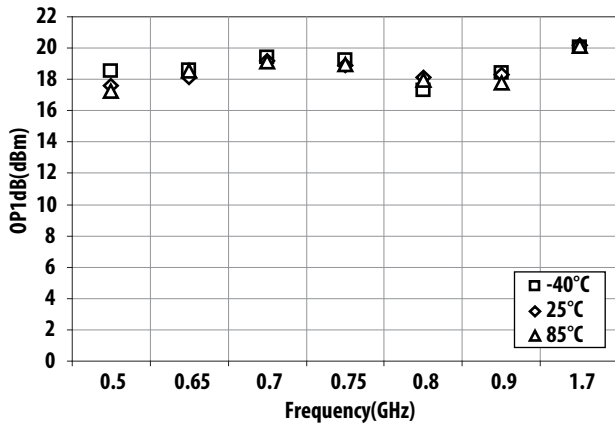

Figure 19. OP1dB vs Frequency and Temperature tuned for Optimum OIP3 and Fmin at 5V 50mA

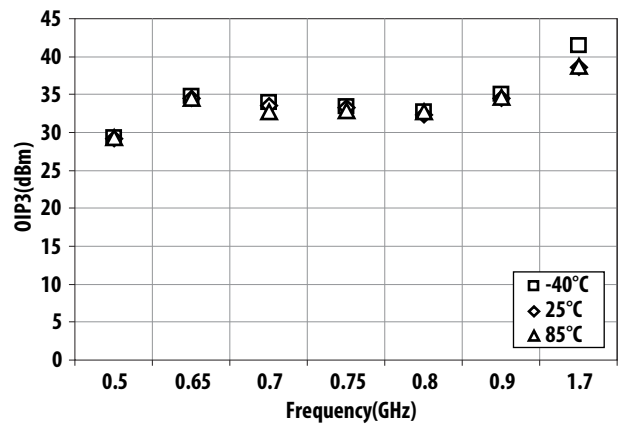

Figure 20. OIP3 vs Frequency and Temperature tuned for Optimum OIP3 and Fmin at 5V 50mA

Below is the table showing the MGA-16516 Reflection Coefficient Parameters tuned for Maximum OIP3, $V_{dd} = 5\text{V}$, $I_{dd} = 50\text{mA}$.

Frequency(GHz)	Gamma Load position		OIP3(dBm)	P1dB(dBm)
	Magnitude	Angle		
0.50	0.472	100.2	29.2	17.6
0.65	0.594	101.1	34.6	18.4
0.70	0.498	119.4	32.6	19.2
0.75	0.457	125.1	32.2	18.9
0.80	0.512	6.9	32.3	18.2
0.90	0.594	-11.5	34.5	18.3
1.70	0.440	24.3	38.6	20.2

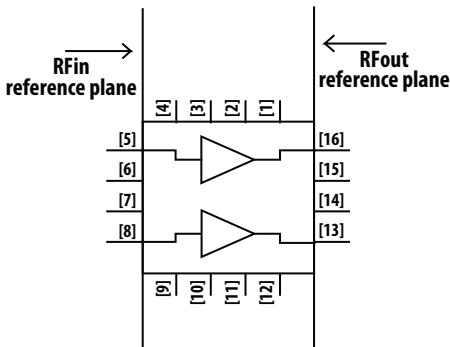

Figure 21.

Notes:

1. The Maximum OIP3 values are calculated based on Load pull measurements on approximately 100 different impedances using Maury's Load pull test system.
2. Measurements are conducted on 0.010 inch thick ROGER 4350. The input reference plane is at the end of the RFin pin and the output reference plane is at the end of the RFout pin as shown in Figure 21.
3. Gamma Load for maximum OIP3 with biasing of 3V 50mA, 3.5V 50mA, 4V 50mA, 4.5V 50mA, 5V 40mA, 5V 50mA and 5V 60mA from 500 MHz to 3.5GHz are available upon request.

MGA-16516 Typical Performance

RF performance at $T_A = 25^\circ\text{C}$, $V_{dd} = 5\text{V}$, $I_{dd} = 50\text{mA}$, given for each RF channel, measured on demo board in Figure 5 with component list in Table 1 for 850 MHz matching. IIP3 is measured with input power of -15dBm per tone.

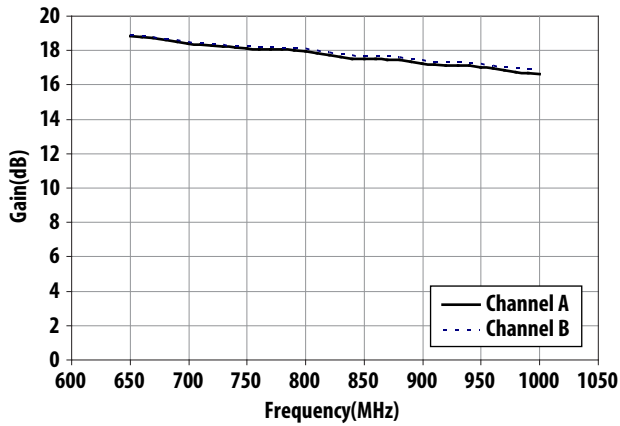

Figure 22. Gain vs Frequency and channel

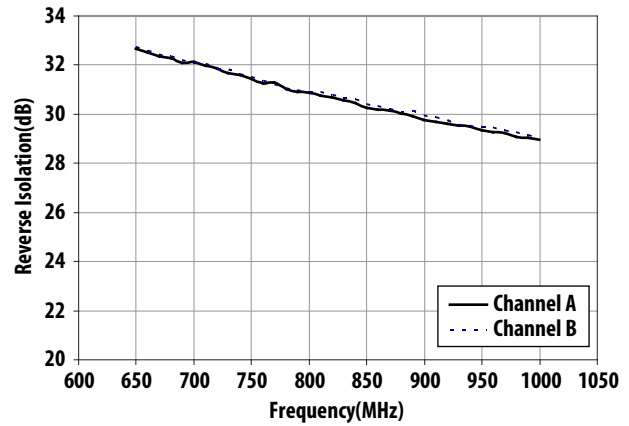

Figure 23. Reverse Isolation vs Frequency and channel

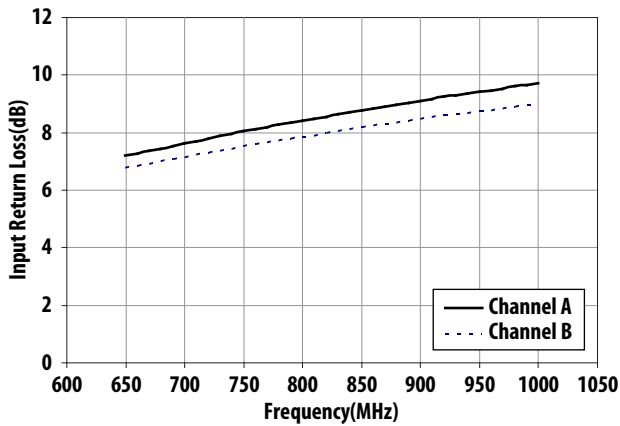

Figure 24. Input Return Loss vs Frequency and channel

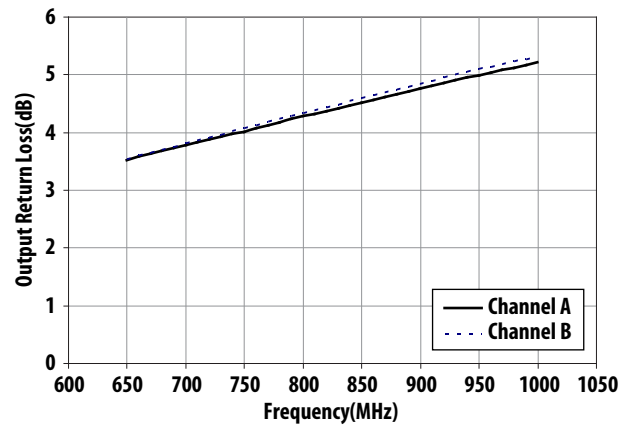

Figure 25. Output Return Loss vs Frequency and channel

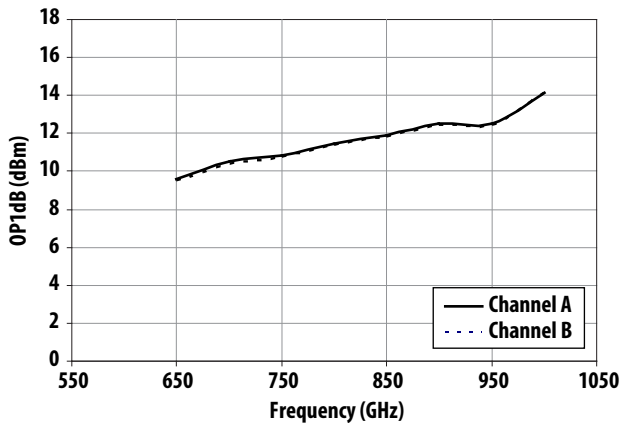

Figure 26. OP1dB vs Frequency and channel

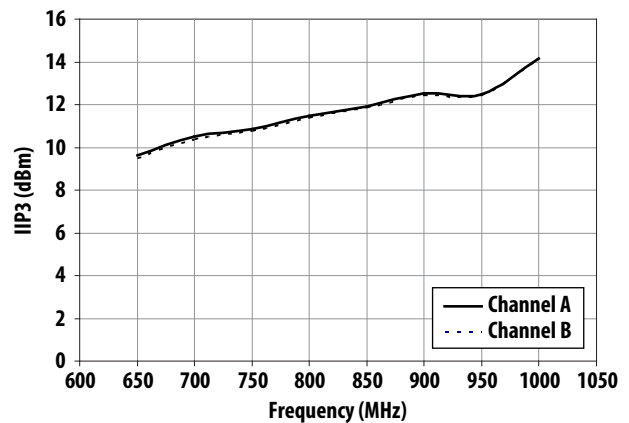

Figure 27. IIP3 vs Frequency and channel

MGA-16516 Typical Performance

RF performance at $T_A = 25^\circ\text{C}$, $V_{dd} = 5\text{V}$, $I_{dd} = 50\text{mA}$, given for each RF channel, measured on demo board in Figure 5 with component list in Table 1 for 850 MHz matching.

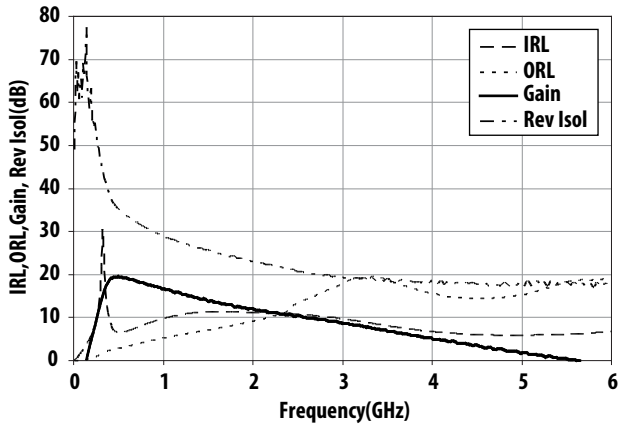

Figure 28. Input Return Loss, Output Return Loss, Gain, Reverse Isolation vs Frequency for channel A

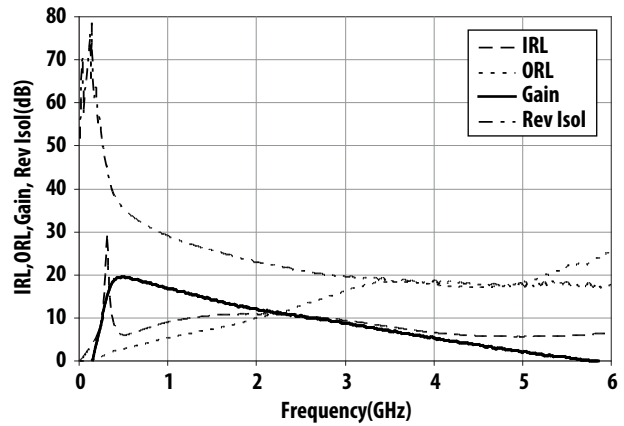

Figure 29. Input Return Loss, Output Return Loss, Gain, Reverse Isolation vs Frequency for channel A

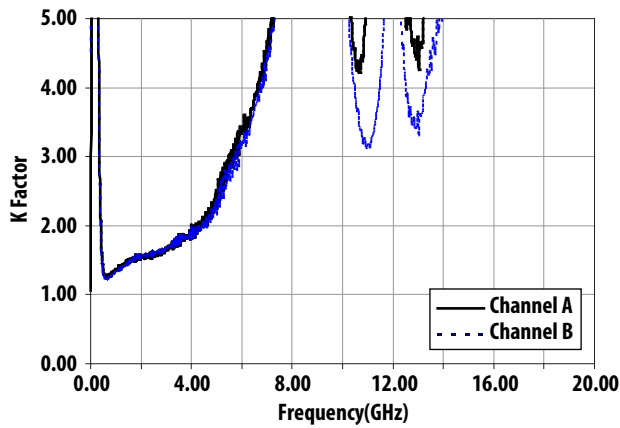

Figure 30. K Factor vs Frequency and channel

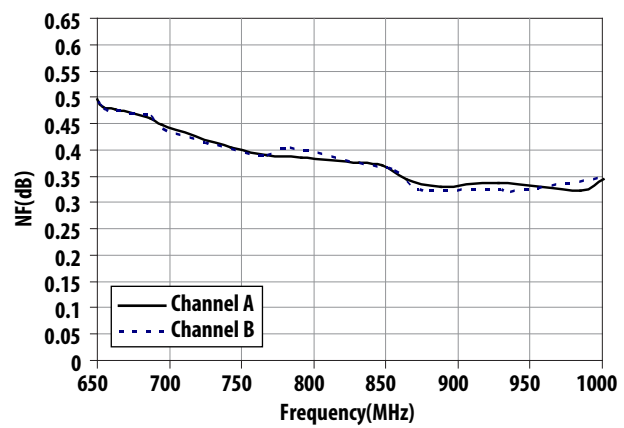

Figure 31. NF vs Frequency and channel

MGA-16516 Typical Scattering Parameters, Vdd=5V, Idd=50mA

Freq GHz	S ₁₁			S ₂₁		S ₁₂		S ₂₂	
	Mag.	Ang.	dB	Mag.	Ang.	Mag.	Ang.	Mag.	Ang.
0.1	0.96	-19.1	28.56	31.87	160.5	0.001	76.8	0.48	-33.2
0.5	0.65	-81.2	24.26	16.33	116.5	0.030	59.5	0.18	-88.0
0.9	0.50	-116.2	20.67	10.80	93.9	0.044	53.0	0.14	-124.9
1.0	0.48	-121.1	19.94	9.94	89.8	0.047	51.7	0.13	-128.2
1.5	0.42	-148.5	16.82	6.94	71.7	0.063	45.7	0.12	-164.5
1.9	0.40	-164.6	14.88	5.54	59.7	0.076	40.4	0.14	171.7
2.0	0.40	-168.1	14.45	5.28	56.9	0.079	38.9	0.14	167.0
2.5	0.40	176.2	12.54	4.24	43.5	0.096	31.5	0.17	146.5
3.0	0.40	161.9	10.89	3.50	30.6	0.111	23.4	0.22	131.7
4.0	0.41	136.4	8.26	2.59	6.8	0.140	6.7	0.30	110.5
5.0	0.44	115.0	6.08	2.01	-16.4	0.163	-11.0	0.38	86.9
6.0	0.45	99.2	4.16	1.61	-36.6	0.183	-26.8	0.46	72.6
7.0	0.45	78.9	2.44	1.32	-58.1	0.197	-44.8	0.55	52.9
8.0	0.45	58.3	0.76	1.09	-78.8	0.207	-62.4	0.64	35.8
9.0	0.48	44.0	-0.83	0.91	-96.3	0.211	-77.6	0.68	21.8
10.0	0.49	40.1	-2.11	0.79	-110.8	0.218	-90.2	0.71	11.8
11.0	0.48	39.6	-3.05	0.70	-124.3	0.228	-102.4	0.71	3.2
12.0	0.44	32.9	-3.78	0.65	-140.1	0.241	-117.1	0.72	-6.6
13.0	0.42	16.4	-4.84	0.57	-157.3	0.242	-133.6	0.76	-17.2
14.0	0.46	0.6	-5.93	0.51	-173.3	0.239	-149.3	0.79	-23.8
15.0	0.52	-1.0	-6.84	0.46	172.1	0.238	-163.8	0.78	-32.8
16.0	0.57	5.2	-7.46	0.42	158.0	0.242	-178.2	0.76	-44.7
17.0	0.60	11.2	-8.01	0.40	145.5	0.247	168.9	0.76	-54.5
18.0	0.62	4.6	-8.44	0.38	133.3	0.253	156.1	0.77	-54.9
19.0	0.65	-12.7	-8.95	0.36	117.9	0.255	140.1	0.77	-57.9
20.0	0.72	-29.3	-10.1	0.31	101.5	0.237	122.9	0.78	-66.1

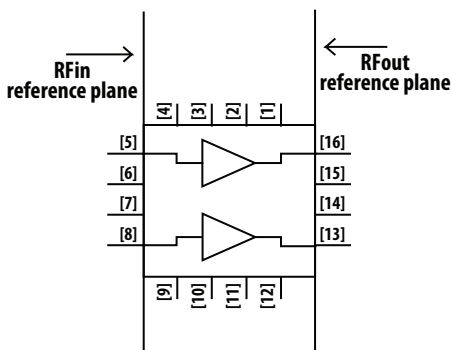

Figure 32.

Typical Noise Parameters, Vdd=5V, Idd=50mA

Freq GHz	Fmin	Γ_{opt}	Γ_{opt}	$R_{n/50}$
	dB	Mag.	Ang.	
0.5	0.32	0.35	-23.36	0.049
0.7	0.32	0.30	-5.38	0.047
0.9	0.33	0.25	1.05	0.061
1.7	0.40	0.26	24.96	0.053
1.85	0.42	0.25	36.84	0.047
2.0	0.45	0.21	95.96	0.039
2.4	0.52	0.17	113.99	0.040
2.6	0.56	0.23	134.72	0.034
3.5	0.69	0.26	172.14	0.035

Notes:

1. The Fmin values are based on noise figure measurements at 100 different impedances using Focus source pull test system. From these measurements a true Fmin is calculated.
2. Scattering and noise parameters are measured on 0.010 inch thick ROGER 4350. The input reference plane is at the end of the RFin pin and the output reference plane is at the end of the RFout pin as shown in Figure 32.
3. S2P file with scattering and noise parameters for biasing 3V 50mA, 3.5V 50mA, 4V 50mA, 4.5V 50mA, 5V 40mA, 5V 50mA and 5V 60mA are available upon request.

Part Number Ordering Information

Part Number	No. of Devices	Container
MGA-16516-BLKG	100	Antistatic Bag
MGA-16516-TR1G	3000	Tape/reel

SLP4X4 Package Dimension

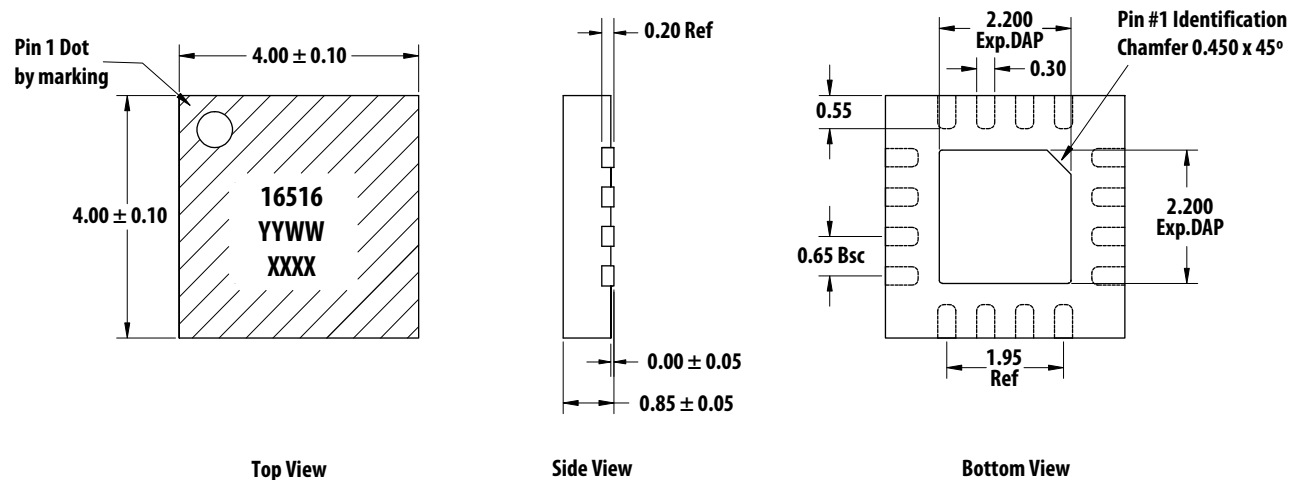

Notes:

1. All dimensions are in millimeters.
2. Dimensions are inclusive of plating.
3. Dimensions are exclusive of mold ash and metal burr.

PCB Land Pattern and Stencil Design

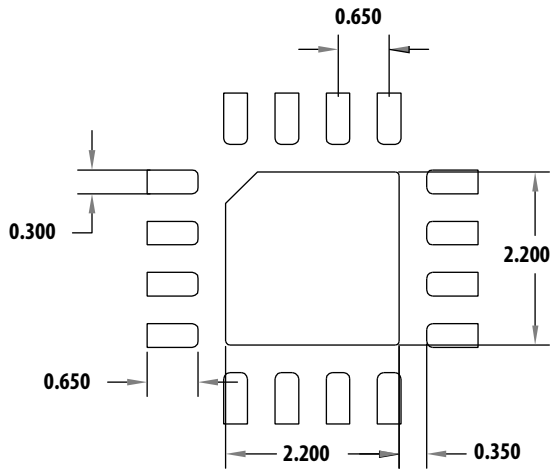

PCB Land Pattern (Top View)

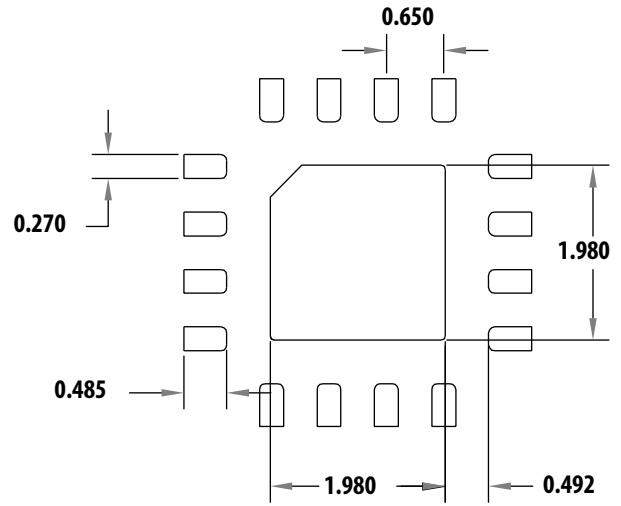

Stencil Outline

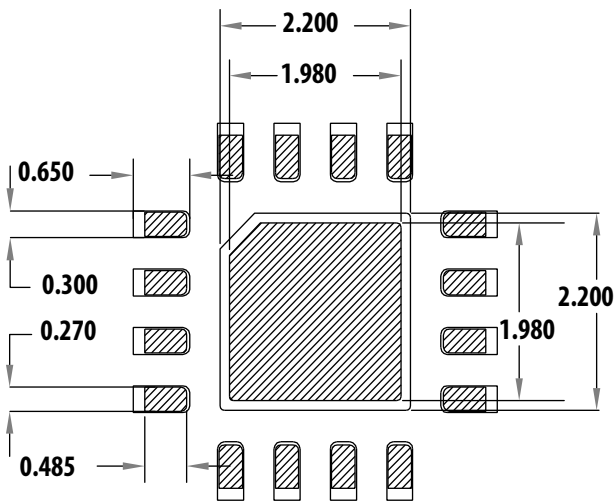

Combines PCB & Stencil Layouts
All Dimension are in millimeters

Device Orientation

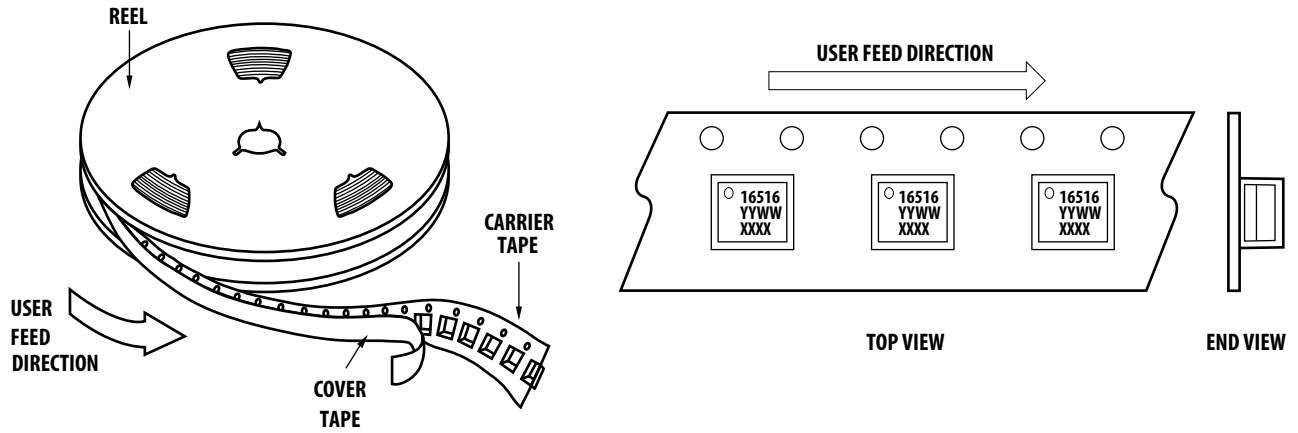

Tape Dimensions

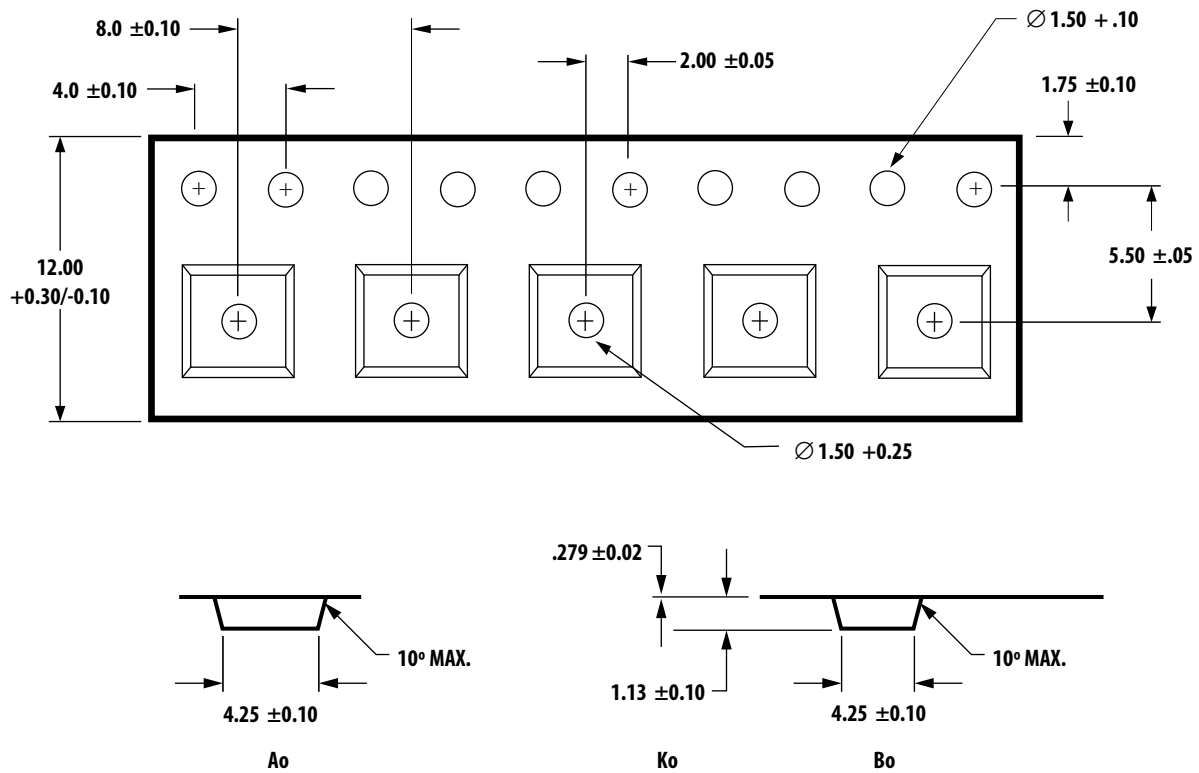

Reel Dimension - 7 Inch

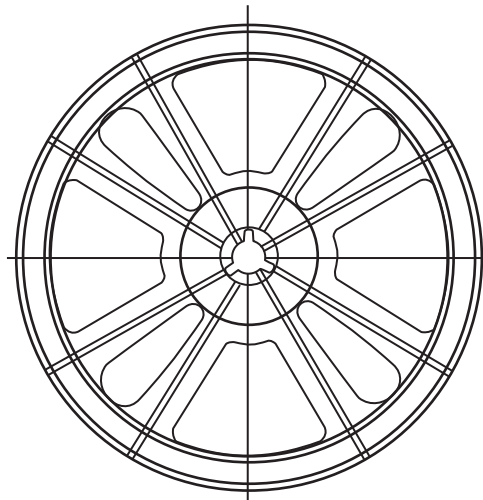

FRONT VIEW

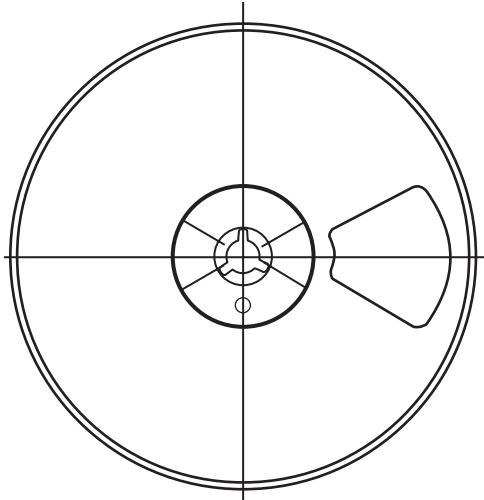

BACK VIEW

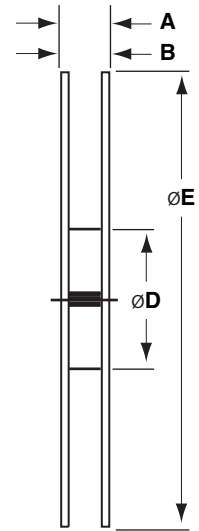

SIDE VIEW

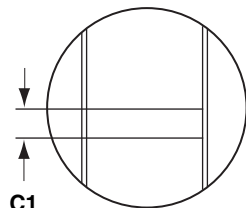

C1

TAPE SLOT
PLANE VIEW

SPECIFICATION								
TAPE WIDTH	A MAX	B +1.5-0.0	C1 ±0.5	∅D ±0.5	∅E (max)	F (min)	∅G ±0.2	∅H (min)
12mm	18.00	12.4	4.40	55.0	178	1.50	13.50	20.20

Note: Surface resistivity to be $<10^{12}$ Ohms/square

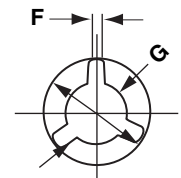

ARBOR HOLE

Reel Dimension - 13 Inch

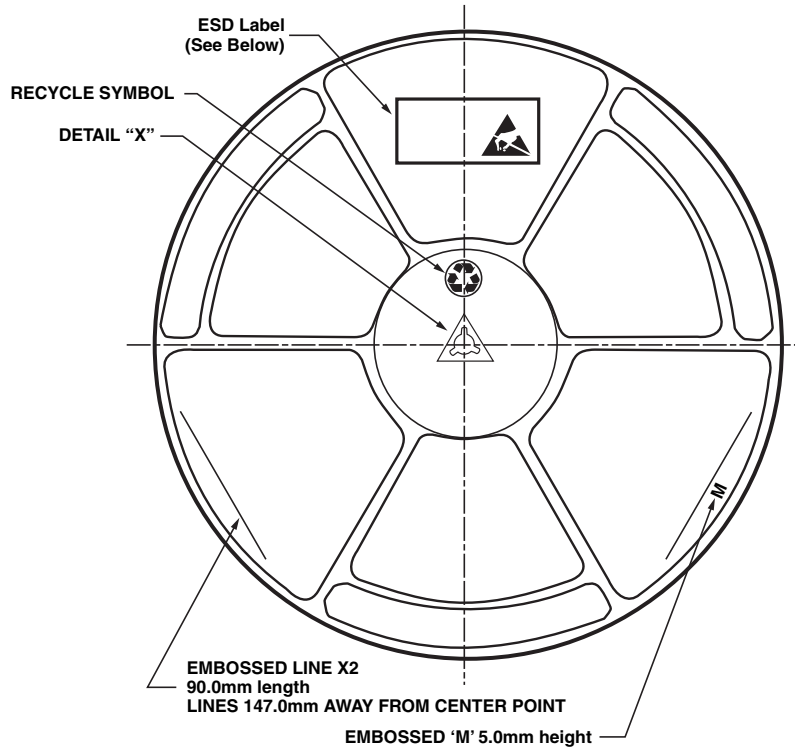

FRONT VIEW

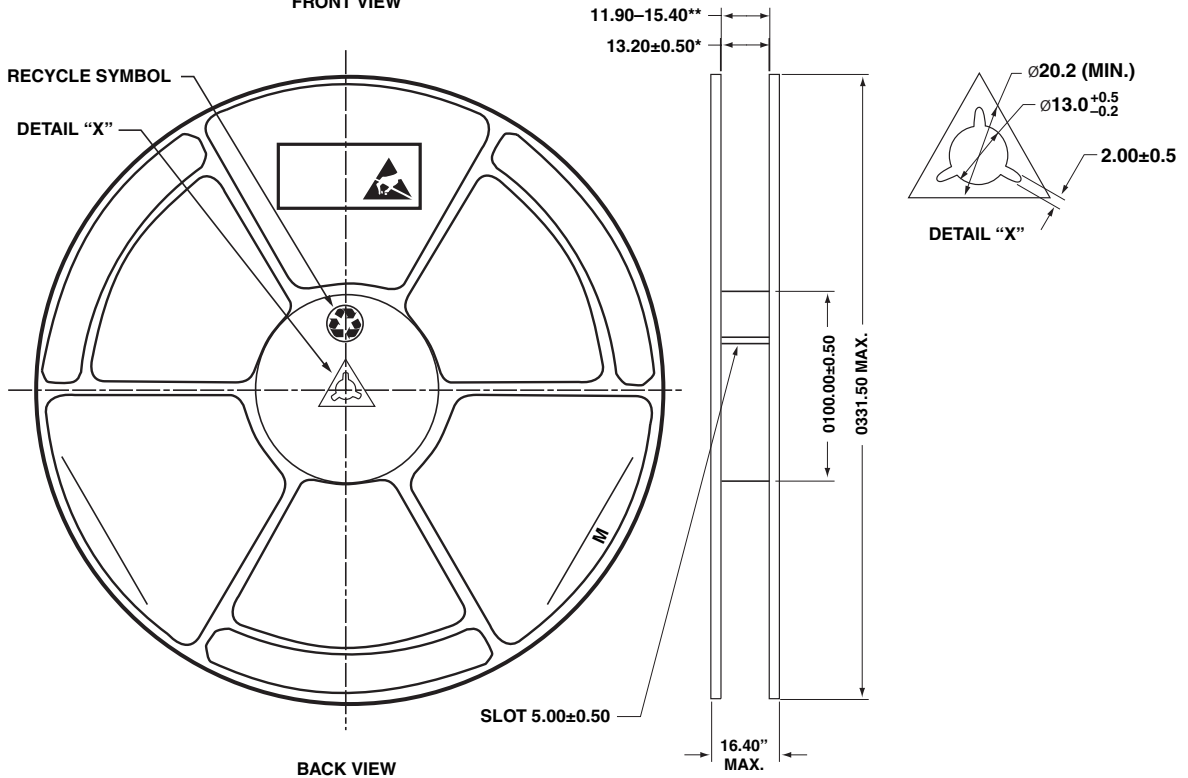

For product information and a complete list of distributors, please go to our web site: www.avagotech.com

Avago, Avago Technologies, and the A logo are trademarks of Avago Technologies in the United States and other countries. Data subject to change. Copyright © 2005-2009 Avago Technologies. All rights reserved. AV02-1980EN - July 7, 2009

