

DRAWING NO.			
7683-103-18-3			
REV:	ECN NO.	DATE:	APP:
1	PRELIM.	8/30/04	JW

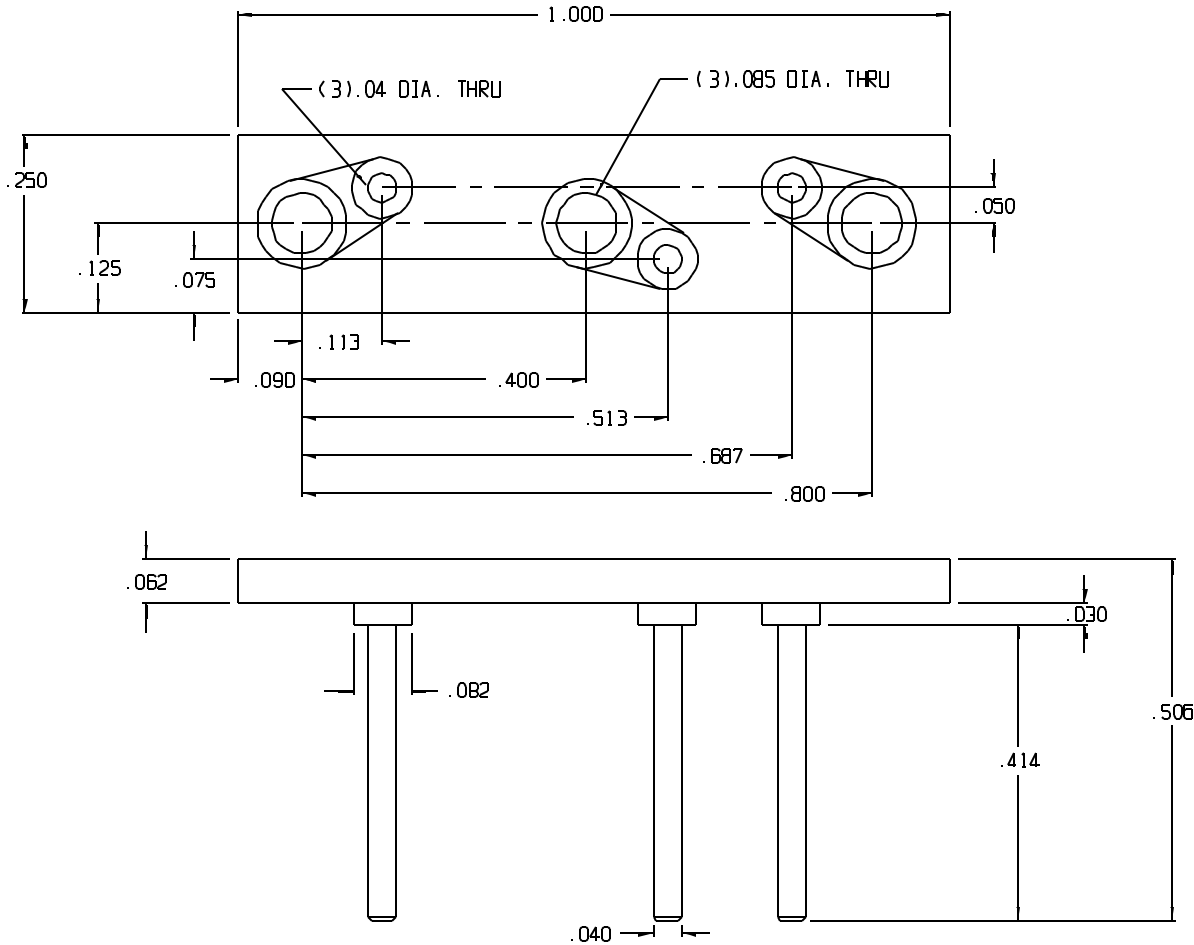

NOTE:  
 1. BOARD MATERIAL: .062 FR-4 PER IPC-4101/26  
 2. PIN MATERIAL: 360 1/2 HARD BRASS.  
 3. PIN PLATING: 200u" MIN. TIN/LEAD PER ASTM B545 OVER 100u" MIN. NICKEL PER SAE AMS-QQ-N-290.

INCH [MM] OR INCH [MM] THIRD ANGLE PROJECTION	TOLERANCES UNLESS OTHERWISE SPECIFIED	MATL: SEE NOTES	SCALE: 1:1 TITLE: POWER SUPPLY ADAPTOR CAC
	0.0 ± .03 0.00 ± .015 0.000 ± .005 ANGLES ± 2°	USED ON: DES: DRW: JAH 8/30/04 MOLD NO.: CKD: APP:	

**ARIES**  
 ELECTRONICS, INC.  
 FRENCHTOWN, N. J. 08825