

## General Description

The AAT3520 series of PowerManager products is part of AnalogicTech's Total Power Management IC™ (TPMIC™) product family. These microprocessor reset circuits are ideal for monitoring voltage supplies in portable systems, where extended battery life is critical. They provide a low-cost, reliable solution by eliminating the need for external components. The AAT3520 series operates by monitoring the system power supply voltage. When the input voltage drops below a fixed threshold, the device asserts a reset signal for a fixed time period after  $V_{CC}$  has risen back above the fixed threshold; 30ms and 150ms minimum periods are available. The AAT3520 product series is guaranteed to operate down to 1.2V and is designed to ignore fast line transients appearing on  $V_{CC}$ . The AAT3520 series is available with three output stage versions: AAT3520 push-pull active high output; AAT3522 push-pull active low output; and AAT3524 open drain active low output. The quiescent supply current is extremely low, typically  $1\mu\text{A}$ , making it ideal for portable battery-operated equipment.

The AAT3520/2/4 are available in a Pb-free, 3-pin SOT23 package and are specified over the  $-40^{\circ}\text{C}$  to  $+85^{\circ}\text{C}$  operating temperature range.

## Features

- Input Voltage Range: 1.2V to 5.5V
- Operation Down to 1.2V
- Extremely Low Quiescent Current:  $<2\mu\text{A}$
- High Accuracy Detection Threshold:  $\pm 1.5\%$
- Monitor Power Supply Voltages
- Fixed Thresholds from 2.2V to 4.6V
- -Reset Pulse Width Options
  - Minimum 30ms or 150ms or 300ms
  - Fast Propagation Delay  $<20\mu\text{s}$
- Available Output Configurations:
  - Open-Drain Output
  - CMOS Active High Output
  - CMOS Active Low Output
- Temperature Range:  $-40^{\circ}\text{C}$  to  $+85^{\circ}\text{C}$
- 3-Pin SOT23 Package
- 4kV ESD Rating

## Applications

- Cell Phones
- Embedded Systems
- Intelligent Instruments
- Notebook Computers
- Portable Electronics

## Typical Application

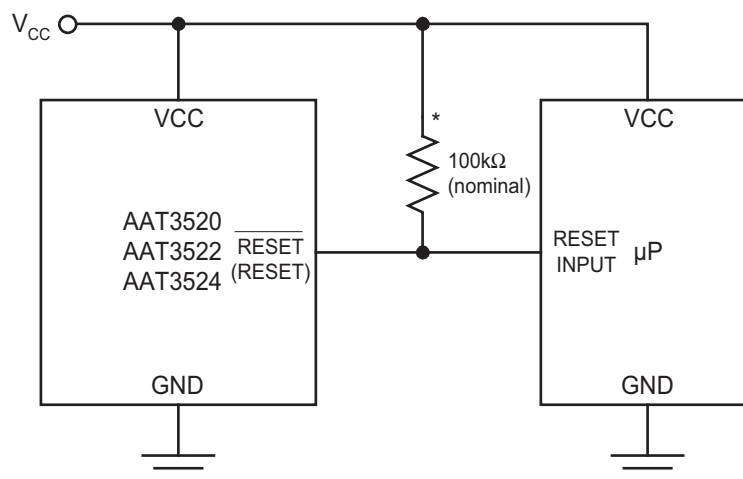

\*AAT3524 Only

## Pin Descriptions

Pin #	Symbol	Function
1	GND	Ground connection.
2	RESET (AAT3520)	RESET output remains high while $V_{CC}$ is below the reset threshold and remains so for a fixed time period after $V_{CC}$ raises above the reset threshold.
	$\overline{\text{RESET}}$ (AAT3522, AAT3524)	$\overline{\text{RESET}}$ output remains low while $V_{CC}$ is below the reset threshold and remains so for a fixed time period after $V_{CC}$ raises above the reset threshold.
3	VCC	Supply voltage (+1.2V to +5.5V). Due to extremely low operating current, place a 10nF capacitor between VCC and GND.

## Part Number Descriptions

Part Number	Part Description
AAT3520	Reset Output Push Pull Active High with Delay
AAT3522	Reset Output Push Pull Active Low with Delay
AAT3524	Reset Output Open Drain Active Low with Delay

## Pin Configuration

SOT23-3  
(Top View)

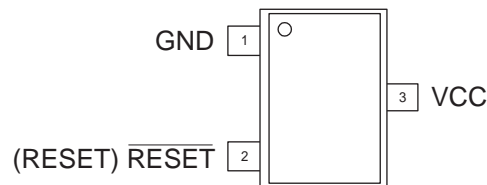

## Absolute Maximum Ratings<sup>1</sup>

T<sub>A</sub> = 25°C, unless otherwise noted.

Symbol	Description	Value	Units
V <sub>CC</sub>	V <sub>CC</sub> to GND	-0.3 to 5.5	V
V <sub>RESET</sub>	RESET to GND (Push-Pull Output)	-0.3 to V <sub>CC</sub> + 0.3	V
	RESET to GND (Open Drain Output)	-0.3 to 5.5	
I <sub>MAX</sub>	Maximum Continuous Input Current	20	mA
I <sub>RESET</sub>	RESET/RESET Current	20	mA
dV <sub>CC</sub> /d <sub>t</sub>	Rate of Rise of V <sub>CC</sub>	100	V/μs
T <sub>J</sub>	Operating Junction Temperature Range	-40 to 150	°C
T <sub>LEAD</sub>	Maximum Soldering Temperature (at Leads, 10 sec.)	300	°C

## Thermal Information<sup>2</sup>

Symbol	Description	Value	Units
Θ <sub>JA</sub>	Maximum Thermal Resistance	200	°C/W
P <sub>D</sub>	Maximum Power Dissipation	320	mW

1. Stresses above those listed in Absolute Maximum Ratings may cause permanent damage to the device. Functional operation at conditions other than the operating conditions specified is not implied. Only one Absolute Maximum Rating should be applied at any one time.  
 2. Mounted on an FR4 board.

## Electrical Characteristics

$V_{IN} = 5V$ ,  $T_A = -40^{\circ}C$  to  $+85^{\circ}C$ , unless otherwise noted. Typical values are at  $T_A = 25^{\circ}C$ ;  $V_{CC} = 5V$  for 4.63/4.38V versions;  $V_{CC} = 3.3V$  for 3.08/2.93V versions;  $V_{CC} = 3.0V$  for 2.63V version;  $V_{CC} = 2.5V$  for 2.32/2.2V versions.

Symbol	Description	Conditions	Min	Typ	Max	Units
$V_{CC}$	Operation Voltage	$T_A = 0^{\circ}C$ to $+70^{\circ}C$	1.0		5.5	V
		$T_A = -40^{\circ}C$ to $+85^{\circ}C$	1.2		5.5	
$I_Q$	Quiescent Current	$V_{CC} = 5.5V$		1.05	3	$\mu A$
		$V_{CC} = 3V$		0.85	2	
$V_{TH}$	RESET Threshold (Table 1)	$T_A = 25^{\circ}C$	$V_{TH} - 1.5\%$	$V_{TH}$	$V_{TH} + 1.5\%$	V
		$T_A = -40^{\circ}C$ to $+85^{\circ}C$	$V_{TH} - 2.5\%$	$V_{TH}$	$V_{TH} + 2.5\%$	
$\Delta V_{TH}/^{\circ}C$	RESET Threshold Temperature Coefficient			40		ppm/ $^{\circ}C$
$t_p$	RESET Propagation Delay	$V_{CC} = V_{TH}$ to $(V_{TH} - 100mV)$		15		$\mu s$
$t_{RDY}$	RESET Active Timeout Period	-50 Option	30	50	100	ms
		-200 Option	150	250	400	
		-400 Option	300	500	800	
$V_{OL}$	RESET Low Output Voltage AAT3522, AAT3524	$I_{SINK} = 1.2mA$ , $V_{CC} = V_{TH(min)}$ , $V_{TH} \leq 3.08V$ , RESET Asserted			0.3	V
		$I_{SINK} = 3.2mA$ , $V_{CC} = V_{TH(min)}$ , $V_{TH} > 3.08V$ , RESET Asserted			0.4	
$V_{OH}$	RESET High Output Voltage AAT3522	$I_{SOURCE} = 800\mu A$ , $V_{TH} > 3.08V$ , $V_{CC} > V_{TH(max)}$	$V_{CC} - 1.5$			V
		$I_{SOURCE} = 500\mu A$ , $V_{TH} \leq 3.08V$ , $V_{CC} > V_{TH(max)}$	$0.8 V_{CC}$			
$V_{OL}$	RESET Low Output Voltage AAT3520	$I_{SINK} = 1.2mA$ , $V_{CC} > V_{TH(max)}$ , $V_{TH} \leq 3.08V$ , RESET Not Asserted			0.3	V
		$I_{SINK} = 3.2mA$ , $V_{CC} > V_{TH(max)}$ , $V_{TH} > 3.08V$ , RESET Not Asserted			0.4	
$V_{OH}$	RESET High Output Voltage AAT3520	$I_{SOURCE} = 500\mu A$ , $V_{CC} > 2.1V$ , RESET Asserted	$0.8V_{CC}$			V
		$I_{SOURCE} = 50\mu A$ , $V_{CC} > 1.2V$ , RESET Asserted	$0.8V_{CC}$			
$I_{DOFF}$	RESET Leakage Current AAT3524	$V_{CC} > V_{TH}$			1	$\mu A$

Typical Characteristics

Supply Current vs. Temperature

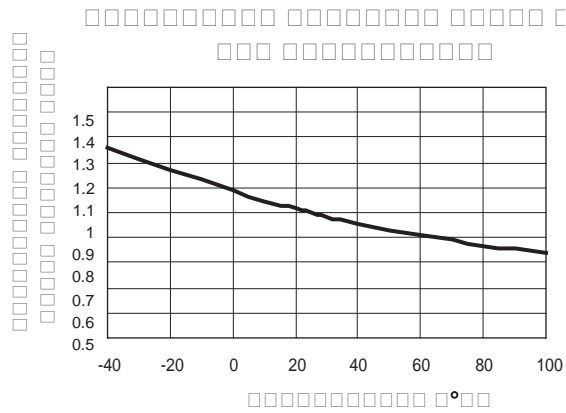
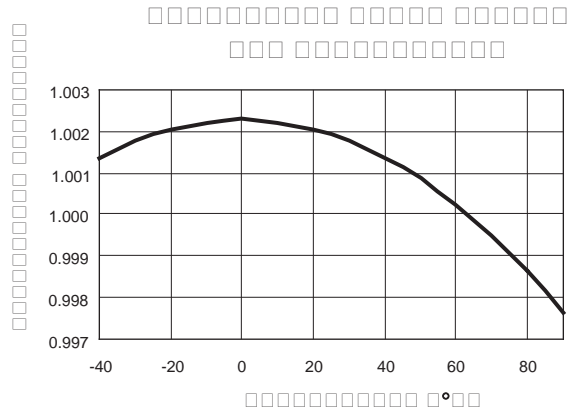
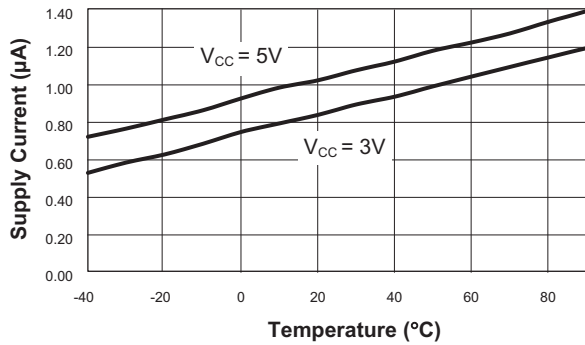

Power-Down Reset Propagation Delay vs. Temperature

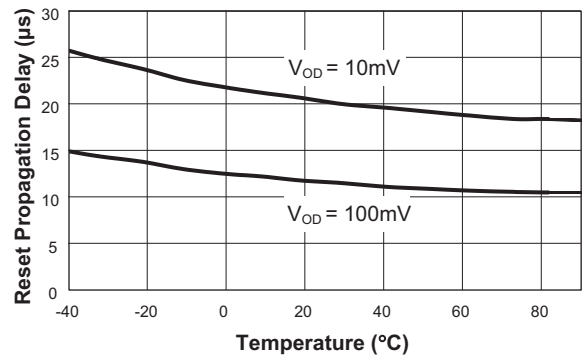

Maximum Transient Duration vs. Reset Threshold Overdrive

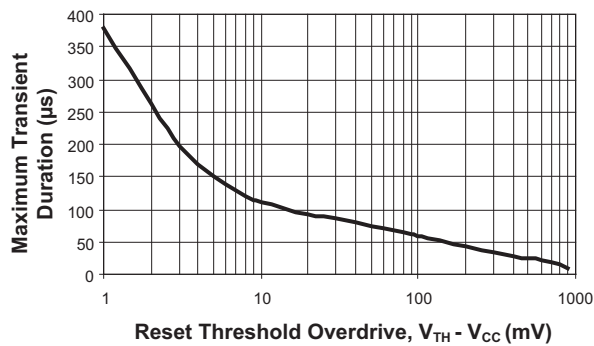

## Functional Block Diagram

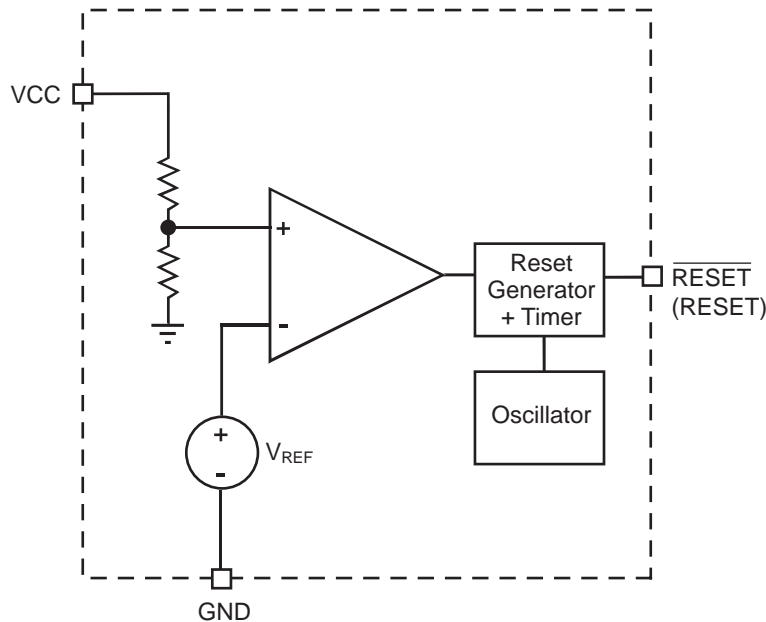

## Functional Description

### General

During start-up, the reset pin on a microprocessor ensures that it is fully reset and starts up in a known condition. The AAT3520 series of microprocessor reset devices monitor the supply voltage to a microprocessor

and assert a reset signal whenever the  $V_{CC}$  voltage falls below a factory-programmed threshold. This threshold is accurate within  $\pm 1.5\%$  at  $25^\circ\text{C}$  and within  $\pm 2.5\%$  over the entire operating temperature range. The reset signal remains asserted for a fixed time period ( $t_{RDY}$ ) after  $V_{CC}$  has risen above the threshold, as shown in Figure 1. See Ordering Information for available RESET active timeout periods.

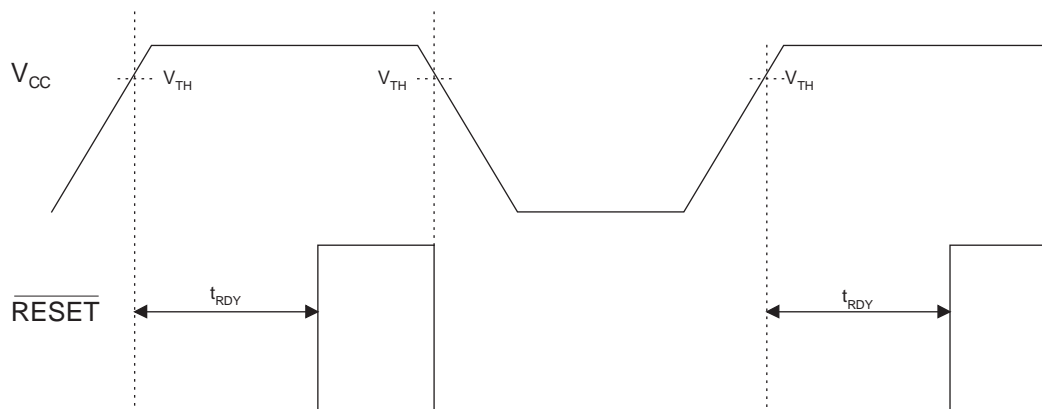

Figure 1: Reset Timing Diagram (AAT3522, AAT3524).

## Applications Information

### Reset Output Options

The AAT3524 has an active low open drain output and the AAT3520/2 have a push-pull output. The AAT3524 may be used in multiple voltage systems with an external pull-up resistor. This allows the AAT3524 to interface to microprocessors with higher supply voltages up to 5.5V (Figure 3). In the event of a power down or brown-out condition, the reset signal remains valid until the  $V_{CC}$  drops below 1.2V. To ensure validity down to ground, an external 100k $\Omega$  resistor should be connected between the RESET output and GND.

### Supply Voltage Transient Behavior

In some cases, fast negative transients of short duration can appear on the  $V_{CC}$  power supply. The AAT3520 series devices provide some immunity to line transients which can generate invalid reset pulses. Figure 1 shows typical behavior to short duration pulses versus RESET comparator overdrive. As shown in the Maximum Transient Duration vs. Reset Threshold Overdrive graph, when the transient voltage becomes larger, the time allowed before asserting a reset becomes shorter (i.e., typically a transient of 100mV below the reset threshold would have to present for more than 50 $\mu$ s to cause a reset). Immunity can be increased by the addition of a small bypass capacitor of 0.1 $\mu$ F connected as closely to the  $V_{CC}$  pin as possible.

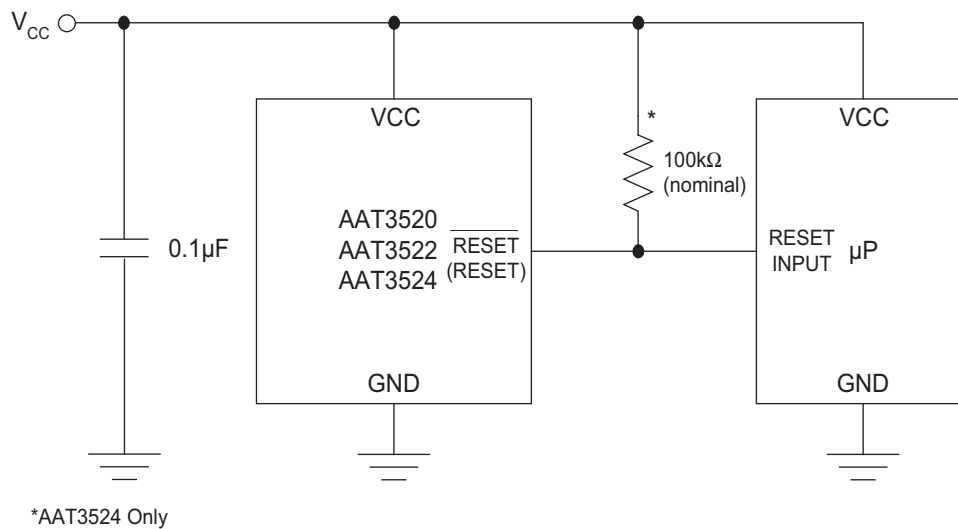

**Figure 2: Using Recommended Bypass Capacitor.**

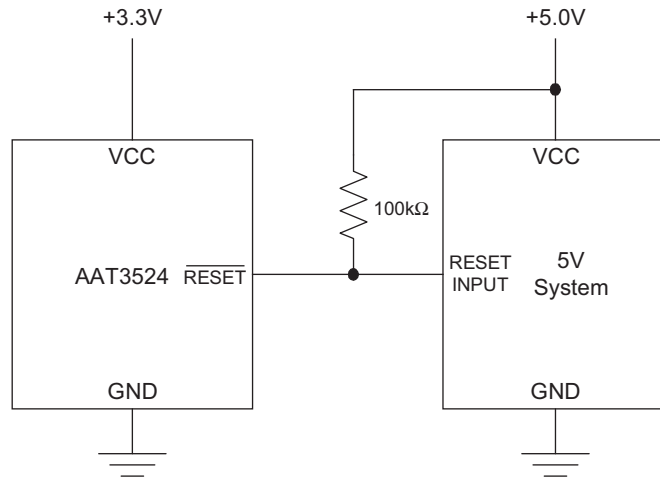

Figure 3: Using AAT3524 Open Drain Output with Multiple Supplies.



**Factory Trimmed Reset Thresholds<sup>1</sup> and Ordering Information**

Ordering Part Number <sup>2</sup>	Marking <sup>3</sup>	Minimum Reset Active (ms)	Reset Threshold Voltage, V <sub>TH</sub> (V)				
			T <sub>A</sub> = 25°C			T <sub>A</sub> = -40°C to +85°C	
			Min	Typ	Max	Min	Max
AAT3522IGY-2.20-200-T1	DBXYY	150	2.167	2.200	2.233	2.145	2.255
AAT3520IGY-2.32-200-T1	DTXYY	150	2.285	2.320	2.355	2.262	2.378
<b>AAT3522IGY-2.32-200-T1</b>		150					
AAT3524IGY-2.32-200-T1		150					
<b>AAT3522IGY-2.45-200-T1</b>	DXXYY	150	2.413	2.450	2.487	2.389	2.511
<b>AAT3520IGY-2.63-200-T1</b>	GNXYY	150	2.591	2.630	2.669	2.564	2.696
<b>AAT3522IGY-2.63-200-T1</b>	CAXYY	150					
<b>AAT3524IGY-2.63-200-T1</b>	CWXYY	150					
<b>AAT3520IGY-2.93-200-T1</b>	CZXYY	150	2.886	2.930	2.974	2.857	3.003
<b>AAT3522IGY-2.93-50-T1</b>	FVXYY	30					
<b>AAT3522IGY-2.93-200-T1</b>	CCXYY	150					
<b>AAT3524IGY-2.93-200-T1</b>	FPXYY	150					
<b>AAT3520IGY-3.08-50-T1</b>	EFXYY	30	3.034	3.080	3.126	3.003	3.157
<b>AAT3520IGY-3.08-200-T1</b>	CNXYY	150					
<b>AAT3522IGY-3.08-50-T1</b>	CYXYY	30					
<b>AAT3522IGY-3.08-200-T1</b>	CBXYY	150					
<b>AAT3524IGY-3.08-200-T1</b>	BGXYY	150					
<b>AAT3524IGY-3.08-400-T1</b>		300					
AAT3520IGY-4.38-200-T1	FUXYY IVXYY	150	4.314	4.380	4.446	4.271	4.490
<b>AAT3522IGY-4.38-200-T1</b>		150					
<b>AAT3524IGY-4.38-200-T1</b>		150					
<b>AAT3520IGY-4.63-200-T1</b>	HKXYY	150	4.561	4.630	4.699	4.514	4.746
<b>AAT3522IGY-4.63-200-T1</b>	DAXYY	150					
<b>AAT3524IGY-4.63-200-T1</b>	DUXYY	150					

1. Contact Local Sales Office for custom trimmed options.  
 2. Sample stock is generally held on part numbers listed in **BOLD**.  
 3. XYY = assembly and date code.

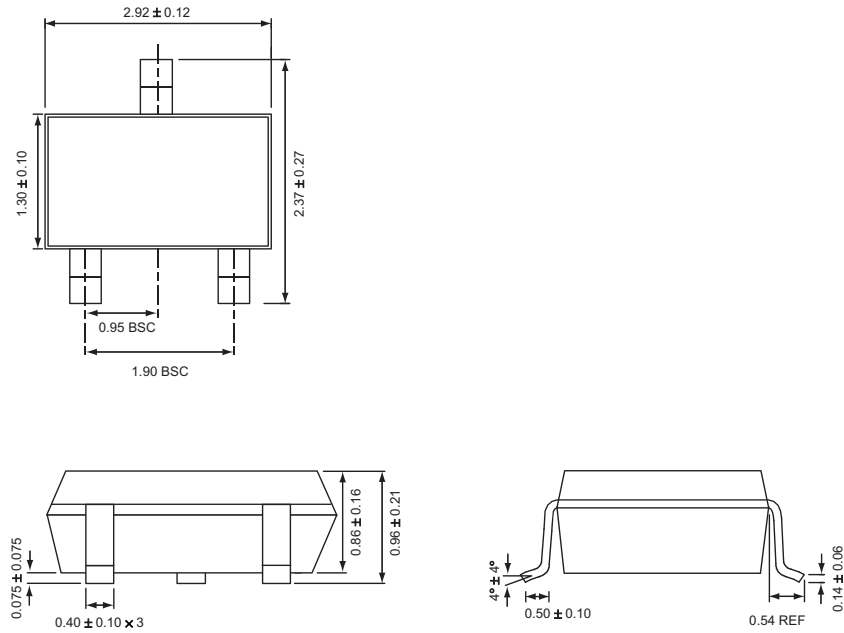
**Package Information**
**SOT23-3**

All dimensions in millimeters.

**Advanced Analogic Technologies, Inc.**  
 3230 Scott Boulevard, Santa Clara, CA 95054  
 Phone (408) 737-4600  
 Fax (408) 737-4611