

AS5510

Linear Hall Sensor with I²C Output

1 General Description

The AS5510 is a linear Hall sensor with 10 bit resolution and I²C interface. It can measure absolute position of lateral movement of a simple 2-pole magnet.

Depending on the magnet size, a lateral stroke of 0.5~2mm can be measured with air gaps around 1.0mm.

To conserve power, the AS5510 may be switched to a power down state when it is not used.

It is available in a WLCSP package and qualified for an ambient temperature range from -20°C to +85°C.

Figure 1. Linear Position Sensor with AS5510 + Magnet

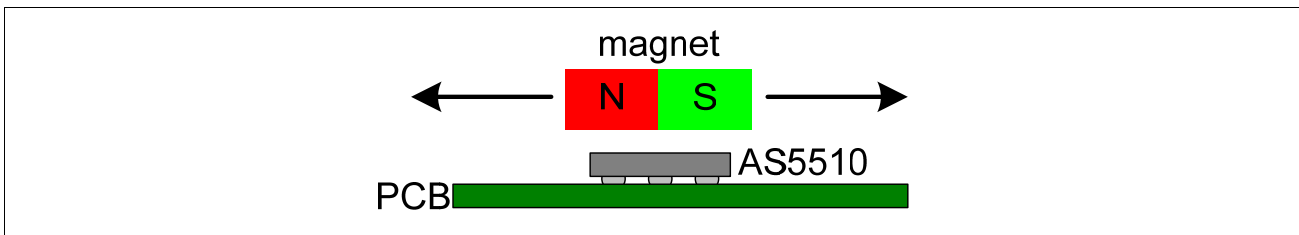

2 The AS5510-AB Adapterboard

The AS5510 adapter board is a simple circuit allowing to test and evaluate the AS5510 linear encoder quickly without having to build a test fixture or PCB.

The adapterboard must be attached to a microcontroller via the I²C bus, and supplied with a voltage of 2.5V ~ 3.6V. A simple 2-pole magnet is placed on the top of the encoder

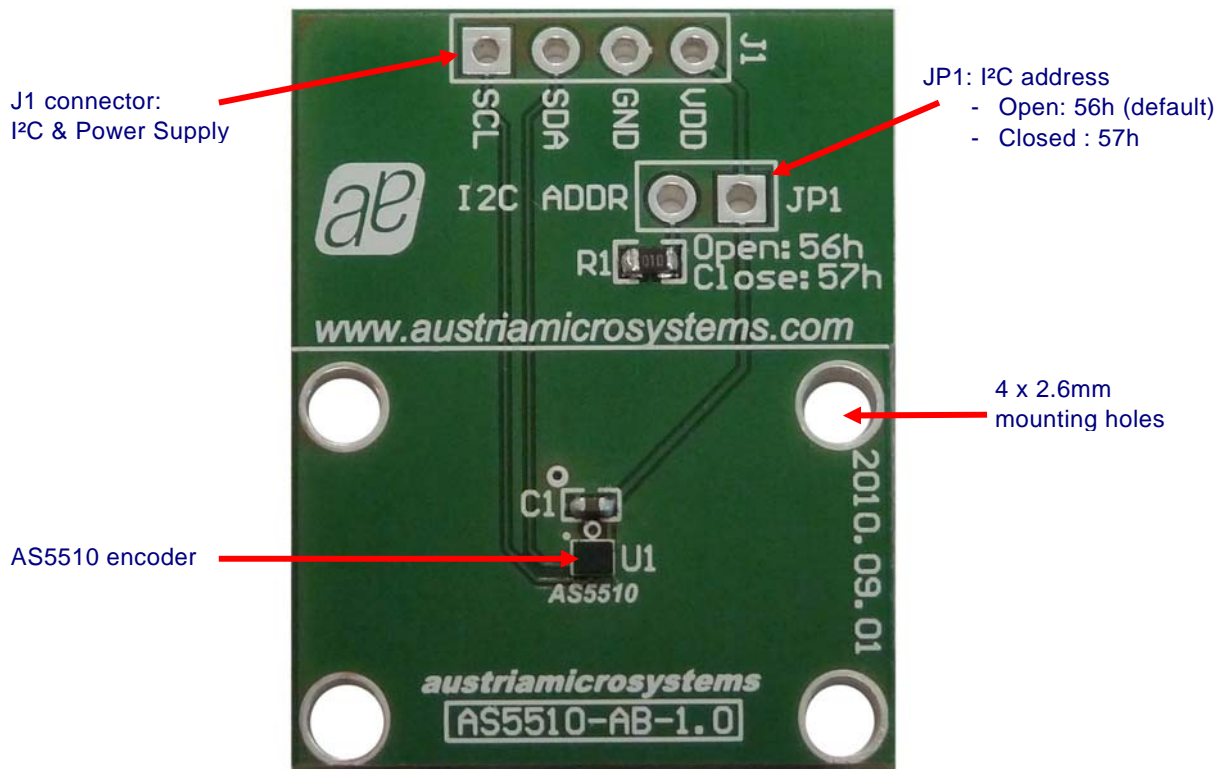

Figure 2: AS5510 Adapterboard

3 Table of Contents

1	General Description	1
2	The AS5510-AB Adapterboard.....	1
3	Table of Contents	2
4	Pinout	3
4.1	Pin Assignments	3
4.2	Pin Description.....	3
5	Operation.....	4
5.1	Mounting the AS5510 Adapter Board	4
5.2	Hardware	7
5.3	Software	8
6	AS5510 adapterboard hardware	9
6.1	AS5510-AB-1.0 Schematics	9
6.2	AS5510-AB-1.0 PCB Layout.....	10
7	Revision History.....	11
8	Copyrights	12
9	Disclaimer.....	12

4 Pinout

4.1 Pin Assignments

The AS5510 is available in a 6-pin Chip Scale Package with a ball pitch of 400µm.

Figure 3. Pin Configuration of AS5510 (Top View)

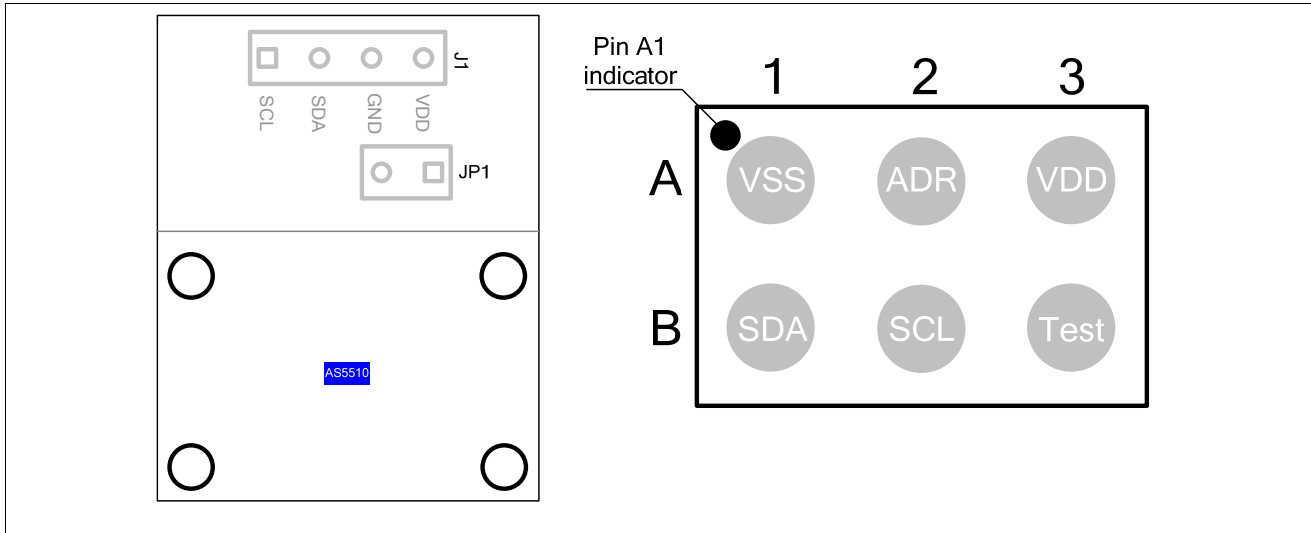

4.2 Pin Description

Table 1. Pin Description AS5510

Pin AB board	Pin AS5510	Symbol	Type	Description
J1: pin 3	A1	VSS	S	Negative supply pin, analog and digital ground.
JP1: Pin 2	A2	ADR	DI	I ² C address selection pin Pull down by default (56h). Close JP1 for (57h)
J1: pin 4	A3	VDD	S	Positive supply pin, 2.5V ~ 3.6V
J1: pin 2	B1	SDA	DI/DO_OD	I ² C data I/O, 20mA driving capability
J1: pin 1	B2	SCL	DI	I ² C clock
n.c.	B3	Test	DIO	Test pin, connected to VSS

DO_OD digital output open drain
DI digital input
DIO digital input/output
S supply pin

5 Operation

5.1 Mounting the AS5510 Adapter Board

Figure 4: AS5510 adapter board mounting and dimension

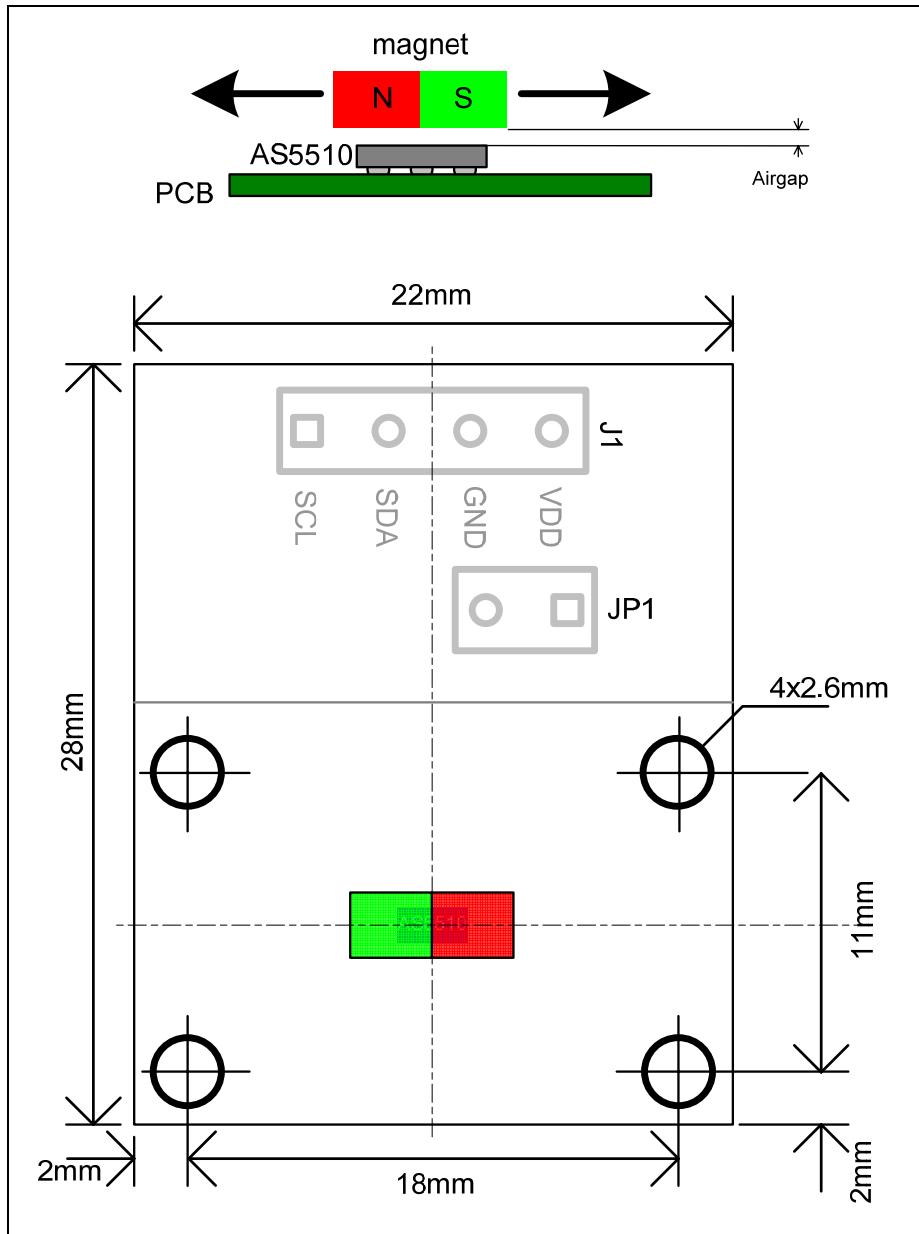

The AS5510-AB can be fixed to an existing mechanical system by its four mounting holes. A simple 2-poles magnet placed over or under the IC can be used.

Figure 5: Magnet requirement

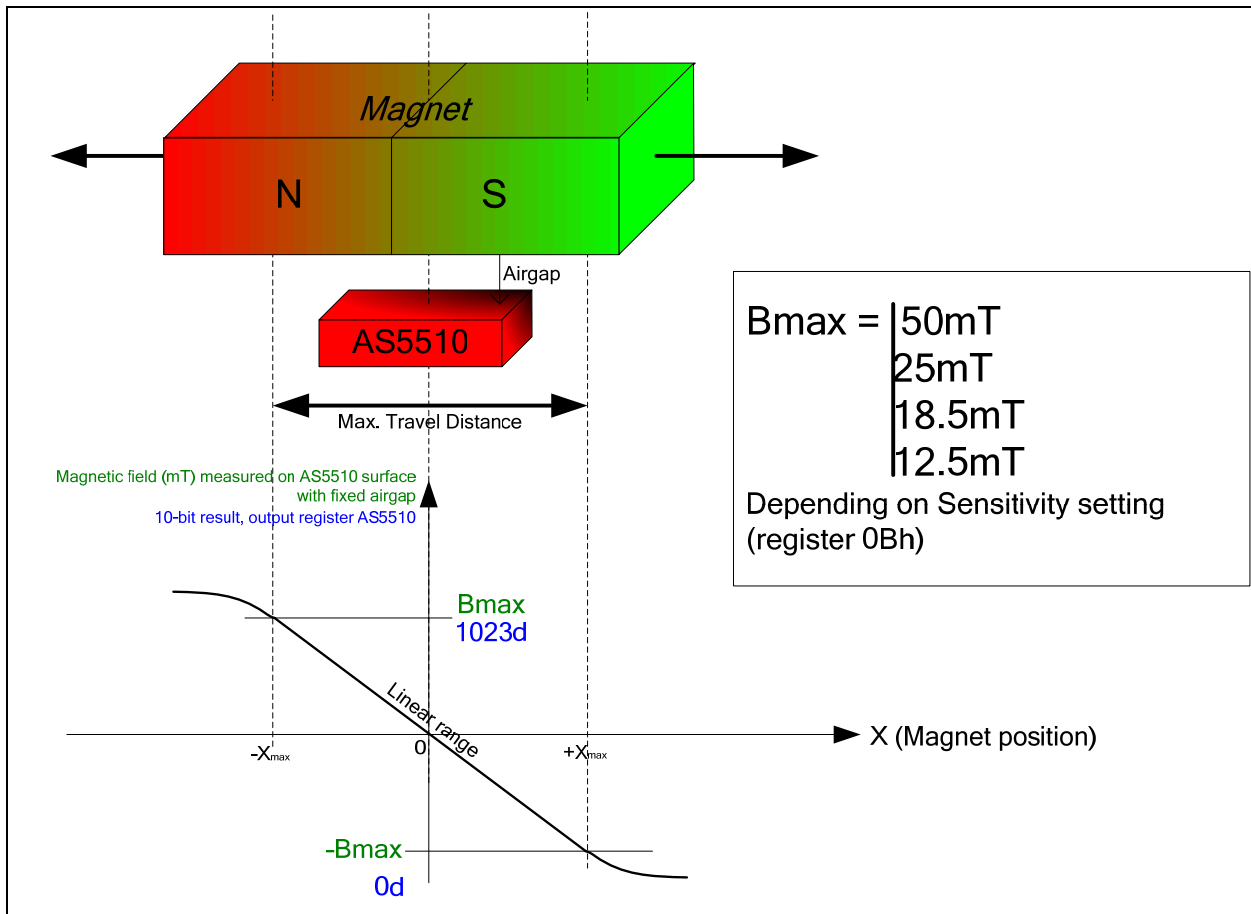

The maximum horizontal travel amplitude depends on the magnet shape and size and magnetic strength (magnet material and airgap).

In order to measure a mechanical movement with a linear response, the magnetic field shape at a fixed airgap must be like on *Figure 5: Magnet requirement*.

The linear range width of the magnetic field between North and South poles determines the maximum travel size of the magnet. The minimum (-Bmax) and maximum (+Bmax) magnetic field values of the linear range must be lower or equal to one of the four sensitivities available on the AS5510 (register 0Bh):

Sensitivity = ± 50mT, ± 25mT, ± 18.5mT, ± 12.5mT

The 10-bit output register D[9..0] OUTPUT = Field_(mT) * (511/Sensitivity) + 511

Example 1:

This is the ideal case: the linear range of the magnet is ±25mT, which fits to the ±25mT sensitivity setting of the AS5510. The resolution of displacement vs. output value is optimal.

Max. Travel Distance TD_{max} = ±1mm (X_{max} = 1mm)

Sensitivity = ±25mT (Register 0Bh ← 01h)

Bmax = 25mT	→ X = -1mm (= -X _{max})	Field _(mT) = -25mT	OUTPUT = 0
	→ X = 0mm	Field _(mT) = 0mT	OUTPUT = 511
	→ X = +1mm (= +X _{max})	Field _(mT) = +25mT	OUTPUT = 1023

Dynamic range of OUTPUT over ±1mm: DELTA = 1023 – 0 = 1023 LSB

Resolution = TD_{max} / DELTA = 2mm / 1024 = **1.95µm/LSB**

Example 2:

Using the same settings on the AS5510, the linear range of the magnet over the same displacement of $\pm 1\text{mm}$ is now $\pm 20\text{mT}$ instead of $\pm 25\text{mT}$ due to a higher airgap or a weaker magnet. In that case the resolution of displacement vs. output value is lower.

Max. Travel Distance $TD_{\text{max}} = \pm 1\text{mm}$ ($X_{\text{max}} = 1\text{mm}$): unchanged

Sensitivity = $\pm 25\text{mT}$ (Register 0Bh \leftarrow 01h) : unchanged

$B_{\text{max}} = 20\text{mT}$	$\rightarrow X = -1\text{mm}$ ($= -X_{\text{max}}$)	Field _(mT) = -20mT	OUTPUT = 102
	$\rightarrow X = 0\text{mm}$	Field _(mT) = 0mT	OUTPUT = 511
	$\rightarrow X = +1\text{mm}$ ($= +X_{\text{max}}$)	Field _(mT) = +20mT	OUTPUT = 920

Dynamic range of OUTPUT over $\pm 1\text{mm}$: DELTA = $920 - 102 = 818$ LSB

Resolution = $TD_{\text{max}} / \text{DELTA} = 2\text{mm} / 818 = \underline{\underline{2.44\mu\text{m}/\text{LSB}}}$

In order to keep the best resolution of the system, it is recommended to adapt the sensitivity as close as the B_{max} of the magnet, with $B_{\text{max}} < \text{Sensitivity}$ to avoid the saturation of the output value.

If a magnet holder is used, this one ferromagnetic in order to keep the maximum magnetic field strength and maximum linearity.

Materials as brass, copper, aluminium, stainless steel are the best choices to make this part.

5.2 Hardware

Two wires (I²C) only are required for the communication with the host MCU.

Pull-up resistors are needed on both SCL and SDA line. The value depends on the length of the wires, and the amount of slaves on the same I²C line.

The power supply delivering between 2.7V ~ 3.6V is connected to the adapter board and the pull-up resistors.

A second AS5510 adapterboard (optional) can be connected on the same line. In that case, the I²C address must be changed by closing JP1 with a wire.

Figure 6. Typical connection to a host MCU (2nd adapterboard is optional).

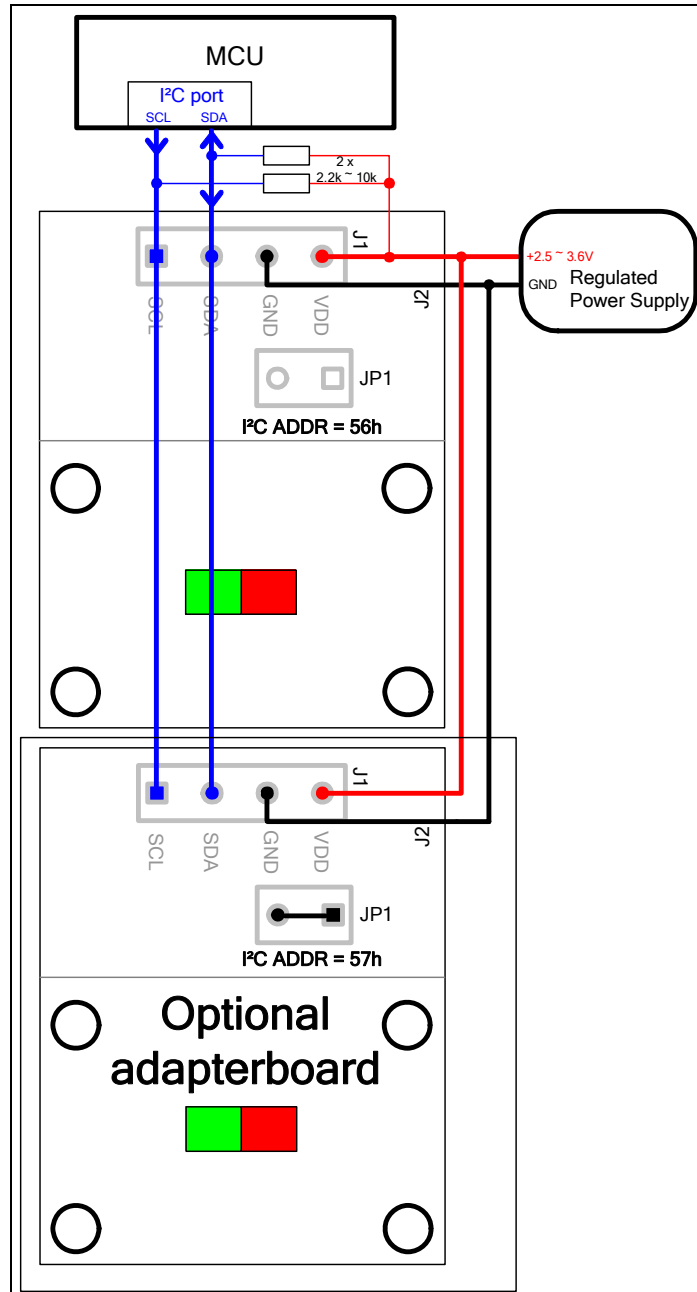

5.3 Software

After powering up the system, a delay of >1.5ms must be performed before the first I²C Read/Write command with the AS5510.

The initialization after power up is optional. It consists of:

- Sensitivity configuration (Register 0Bh)
- Magnet polarity (Register 02h bit 1)
- Slow or Fast mode (Register 02h bit 3)
- Power Down mode (Register 02h bit 0)

Reading the magnetic field value is straight forward. The following source code reads the 10-bit magnetic field value, and converts to the magnetic field strength in mT (millitesla).

Example: Sensitivity configured to +-50mT range (97.66mT/LSB), Polarity = 0, this is the default setting:

- D9..0 value = 0 means -50mT on the hall sensor.
- D9..0 value = 511 means 0mT on the hall sensor (no magnetic field, or no magnet).
- D9..0 value = 1023 means +50mT on the hall sensor.

```
Void main_loop(unsigned char Sensitivity_Mode)
{
    unsigned char Data1, Data2;
    short value;           // 10-bit output value (0~1023)
                          // The value 511 is the middle point @ 0mT
    float magnetic_field; // Value of the magnetic field in mT

    Data_LSB = I2C_Read8(I2C_ADDR, 0x00); // Read D7..0
    Data_MSB = I2C_Read8(I2C_ADDR, 0x01); // Read D9..8 + OCF + Parity

    value = ((Data_MSB & 0x03)<<8) + Data_LSB;

    switch (Sensitivity_Mode) // Sensitivity_Mode is the value stored in
                              // register 0Bh
    {
        case 0: // Register [0Bh] <= 0 (+- 50mT range, 97.66uT/LSB)
            magnetic_field = (value - 511) * 0.09766;
            break;

        case 1: // Register [0Bh] <= 0 (+- 25mT range, 48.83uT/LSB)
            magnetic_field = (value - 511) * 0.04883;
            break;

        case 2: // Register [0Bh] <= 0 (+- 12.5mT range, 24.41uT/LSB)
            magnetic_field = (value - 511) * 0.02441;
            break;

        case 3: // Register [0Bh] <= 0 (+- 18.7mT range, 36.62uT/LSB)
            magnetic_field = (value - 511) * 0.03662;
            break;
    }

    printf("Decimal 10-bit value = %u \n", value);
    printf("Magnetic field value = %.3fmT \n", magnetic_field);
}
```

6 AS5510 adapterboard hardware

6.1 AS5510-AB-1.0 Schematics

Figure 7. AS5510-AB-1.0 adapterboard schematics

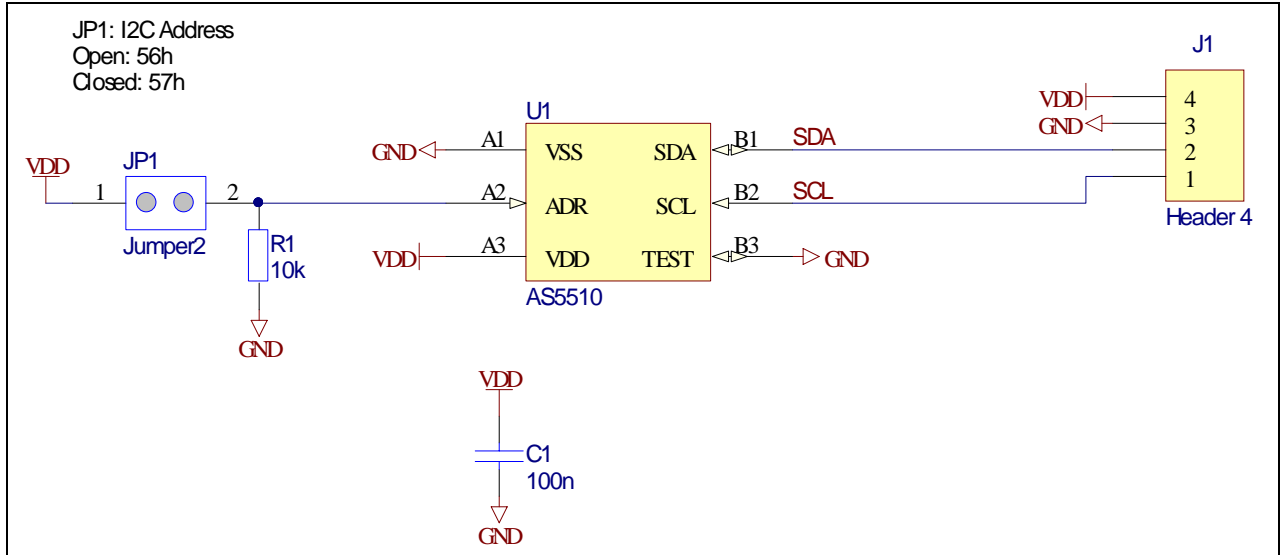

6.2 AS5510-AB-1.0 PCB Layout

Figure 8. AS5510-AB-1.0 adapterboard layout

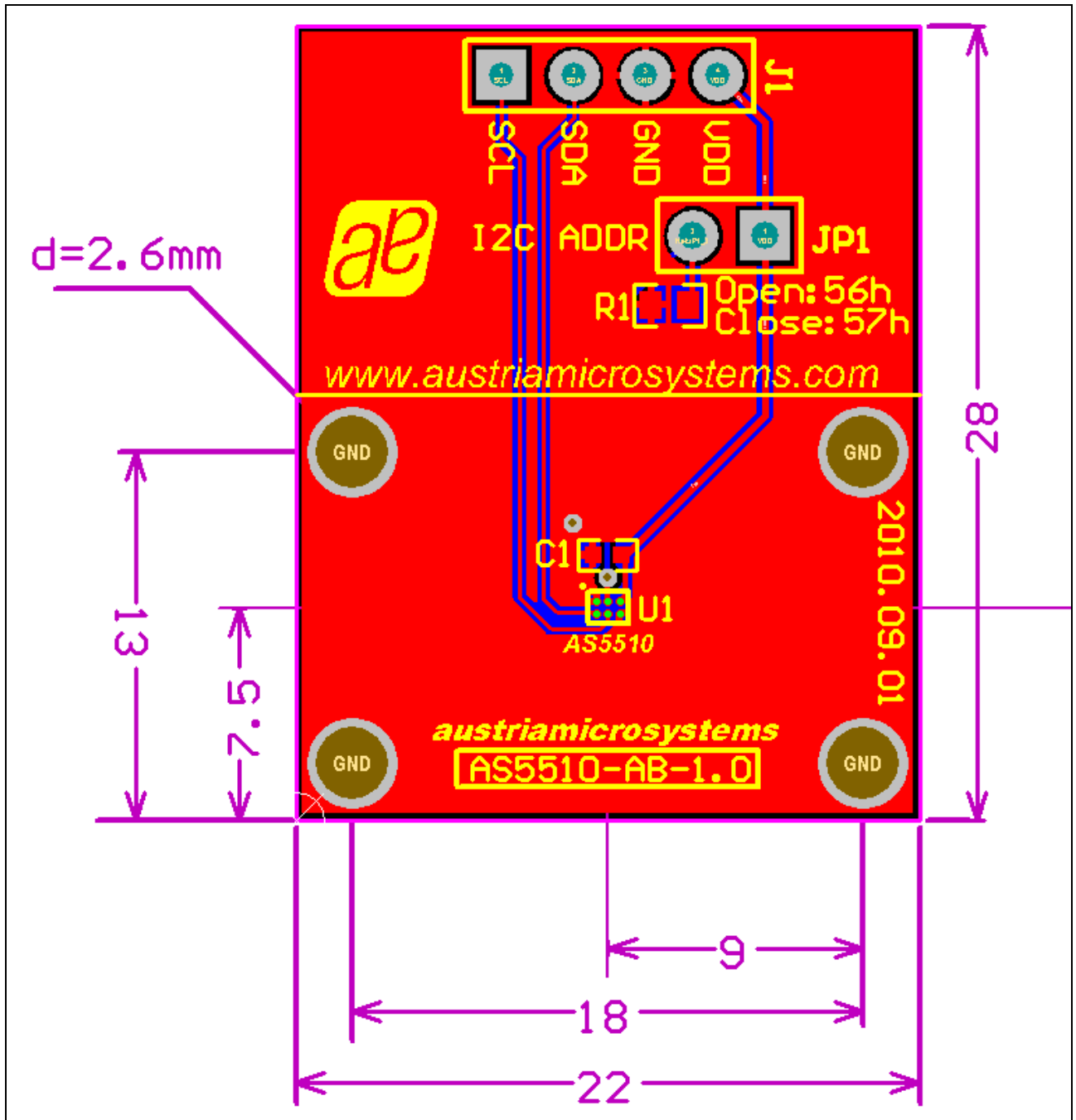

7 Revision History

Table 2. Revision History

Revision No.	Description	Change Date
0.1	Initial revision	17. Sep. 2010

8 Copyrights

Copyright © 2010, austriamicrosystems AG, Schloss Premstaetten, 8141 Unterpremstaetten, Austria – Europe. Trademarks Registered ®. All rights reserved. The material herein may not be reproduced, adapted, merged, translated, stored, or used without the prior written consent of the copyright owner. All products and companies mentioned are trademarks or registered trademarks of their respective companies.

9 Disclaimer

Devices sold by austriamicrosystems AG are covered by the warranty and patent indemnification provisions appearing in its Term of Sale. austriamicrosystems AG makes no warranty, express, statutory, implied, or by description regarding the information set forth herein or regarding the freedom of the described devices from patent infringement. austriamicrosystems AG reserves the right to change specifications and prices at any time and without notice. Therefore, prior to designing this product into a system, it is necessary to check with austriamicrosystems AG for current information. This product is intended for use in normal commercial applications. Applications requiring extended temperature range, unusual environmental requirements, or high reliability applications, such as military, medical life-support or life sustaining equipment are specifically not recommended without additional processing by austriamicrosystems AG for each application.

The information furnished here by austriamicrosystems AG is believed to be correct and accurate. However, austriamicrosystems AG shall not be liable to recipient or any third party for any damages, including but not limited to personal injury, property damage, loss of profits, loss of use, interruption of business or indirect, special, incidental or consequential damages, of any kind, in connection with or arising out of the furnishing, performance or use of the technical data herein. No obligation or liability to recipient or any third party shall arise or flow out of austriamicrosystems AG rendering of technical or other services.



Contact Information

Headquarters

austriamicrosystems AG
A-8141 Schloss Premstaetten, Austria
Tel: +43 (0) 3136 500 0
Fax: +43 (0) 3136 525 01

For Sales Offices, Distributors and Representatives, please visit:

<http://www.austriamicrosystems.com/contact>